

# ATEX FLAMEPROOF LEADLAMP FROM WOLF OPERATING & MAINTENANCE INSTRUCTIONS

**Maintenance must only be carried out in a safe area and with the supply disconnected**

Repairs, maintenance and bulb changing only to be undertaken in a by trained personnel to the requirements of EN60079-14, Electrical installations in hazardous areas (other than mines) and EN60079-17 Inspection and maintenance of electrical installations in hazardous areas (other than mines) .

## To replace the bulb

Ensure that the bulb has cooled. Remove the lock screw on the front face of the lamp lens ring, the screw can be seen through hole in hexagonal rubber shroud.

The rubber shroud and lens ring assembly complete can then be unscrewed from the leadlamp body in an anti clockwise direction. Care must be taken not to damage the threads on the lens assembly as this is the critical joint of the flameproof enclosure. There is a screw securing the bulb to the bulb holder, remove screw and disconnect the male spade terminal from the switch wire. Replace with correctly rated bulb and re-assemble.

## To replace the reflector

Remove the lens assembly by undoing the wire clip on the outside diameter of the reflector. **Caution**, the spring is under tension and may recoil with some force. Safety glasses should be worn. Please note the glass lens cannot be replaced as this is permanently set into the lens ring.

Assembly is the reverse of the above, ensure threads are not crossed and the sealing "O" ring is fitted.

## Switch replacement

To replace the switch remove lens assembly as above, unscrew switch plate securing screws (x2) and de solder wire connections. Note which terminals are connected to which wire. The switch actuating rod can be taken out when the circlip on the end of the shaft is removed. Ensure the "O" ring on the shaft is in good condition. There should be no sign of wear on either the bore or the shaft.

## Fitting / Replacement of Cable

Remove the two screws on the cable clamp on the Ex cable entry gland. Unscrew the cable clamp (small hexagonal nut) from the gland body, to loosen the rubber-sealing washer, so that cable can be pulled through. The gland does not need to be disassembled.

Unscrew the three socket screws securing the handle. Slide handle back over cable. The Increased Safety cable terminals are now accessible to fit the cable. Replacement cable **MUST** be suitable for the operating voltage / current and for the environment it is to be used in. Assembly is reverse of above. Ensure cable gland seal is in good condition. Do not over tighten socket screws for the handle this may distort and stress the moulding.

## Spare Parts List

Spare Part Number	Description	Spare Part Number	Description
LL-210	Switch	LL-262	Handle 24 volt (handle is printed with voltage)
LL-212	Switch actuating rod	LL-264	Handle 42 volt (handle is printed with voltage)
LL-205	Switch spring	LL-266	Socket screws for handle ,including washers (x3)
LL-206	E clip for actuating rod	LL-268	Cable retainer
LL-220	Lamp holder complete	LL-270	Complete lens ring assembly
LL-230	Bulb 12 volt 50 watt	LL-272	Lock screw
LL-232	Bulb 24 volt 70 watt	LL-274	Reflector
LL-234	Bulb 42 volt 65 watt	LL-276	Isolating rubber seal for reflector
LL-240	Hexagonal rubber shroud	LL-278	Reflector retaining spring
LL-250	Rubber seal (Handle to flameproof head)	LL-284	Terminal bush (EEx d)
LL-252	Rubber "o" seal (Lens ring assembly)	LL-286	Leather carrying strap
LL-260	Handle 12 volt (handle is printed with voltage)	LL-288	Cable gland

LL-106 issue 1

## ATEX Type KHLE 70 EN Model

 **EEx de IIC T3/T4.**

**Certificate of Conformity: BVS03ATEXE279**  
**Environmental conditions, -20°C to +40°C**



0158 **EMC compliant to 2004/108/EC**

Flameproof Leadlamp Technical Specification			
Model Number	LL-12	LL-24	LL-42
Code	II 2 G EEx d e IIC T3, T4		
Certification	BVS03ATEXE279		
Temperature class	T4	T3	T3
Input voltage	12V	24V	42V
Wattage	55W	70W	65W
Insulation class	III		
IP Rating	IP54		
Weight	2.5 Kg		

Note voltage tolerance +10%, - 15%

## Applications and Use of Flameproof Lead Lamp in Hazardous Areas

The Flameproof Lead Lamp meets all relevant provisions of the 94/9/EC (ATEX Equipment) Directive. The lamp output is a bright focused halogen beam powered from 12V, 24V or 42V AC/DC, depending on model. The lamp housing is made of aluminium alloy, the handle is made from high impact thermoset plastic. It is fitted with a protective glass lens and a hexagon rubber shroud guards it against impact damage. The lamp is supplied complete with leather carrying strap and a bulb. Cable can be supplied on request.

The Lamp can be used in Zone 1 and 2 Hazardous Areas for inspection, maintenance, cleaning and other work tasks and in association with shot blasting and recoating of tanks, boilers, pressure vessels and silos.

Copies of BVS Certificate number **BVS03ATEXE279** are available upon request.

Users and Maintainers should consult EN60079 Selection and Installation of Electrical Apparatus for use in potentially explosive atmospheres, and classification of industrial Hazardous Areas.

If a lamp becomes damaged, it should be withdrawn from service and thoroughly checked over, and repaired, as necessary before being put back into service.

Maintenance and Repair must only be carried out by a competent technician or electrician familiar with Certified Electrical Apparatus in accordance with European guidelines EN60079-17 codes of practice and these maintenance instructions, using only factory supplied spare parts.

**LAMPS MUST NOT BE OPENED IN A HAZARDOUS AREA.**

**All maintenance activities must be carried out in a safe non-hazardous area.**

## Transformers (Hazardous Area)

Transformers, plugs and sockets must be certified for use in appropriate Hazardous Areas. Selection to be carried out by suitably qualified engineer.

## Transformers (Safe Area)

12 to 50 volt Transformers can be used to supply these products. If a non explosion protected transformer is used it should be sited in the safe non hazardous area. Selection to be carried out by suitably qualified engineer.

## Cabling and Plugs

The user must ensure correct cable type is used for the application. Many oil and gas companies insist on wire braided cable with a cover of HOFER, heat oil and flame resistant sheath. Three core earthed. Length must not exceed 20 metres.

# Flameproof Leadlamp

type .... KHLE 70 EN

model no's .... LL-12, LL-24 and LL-42.

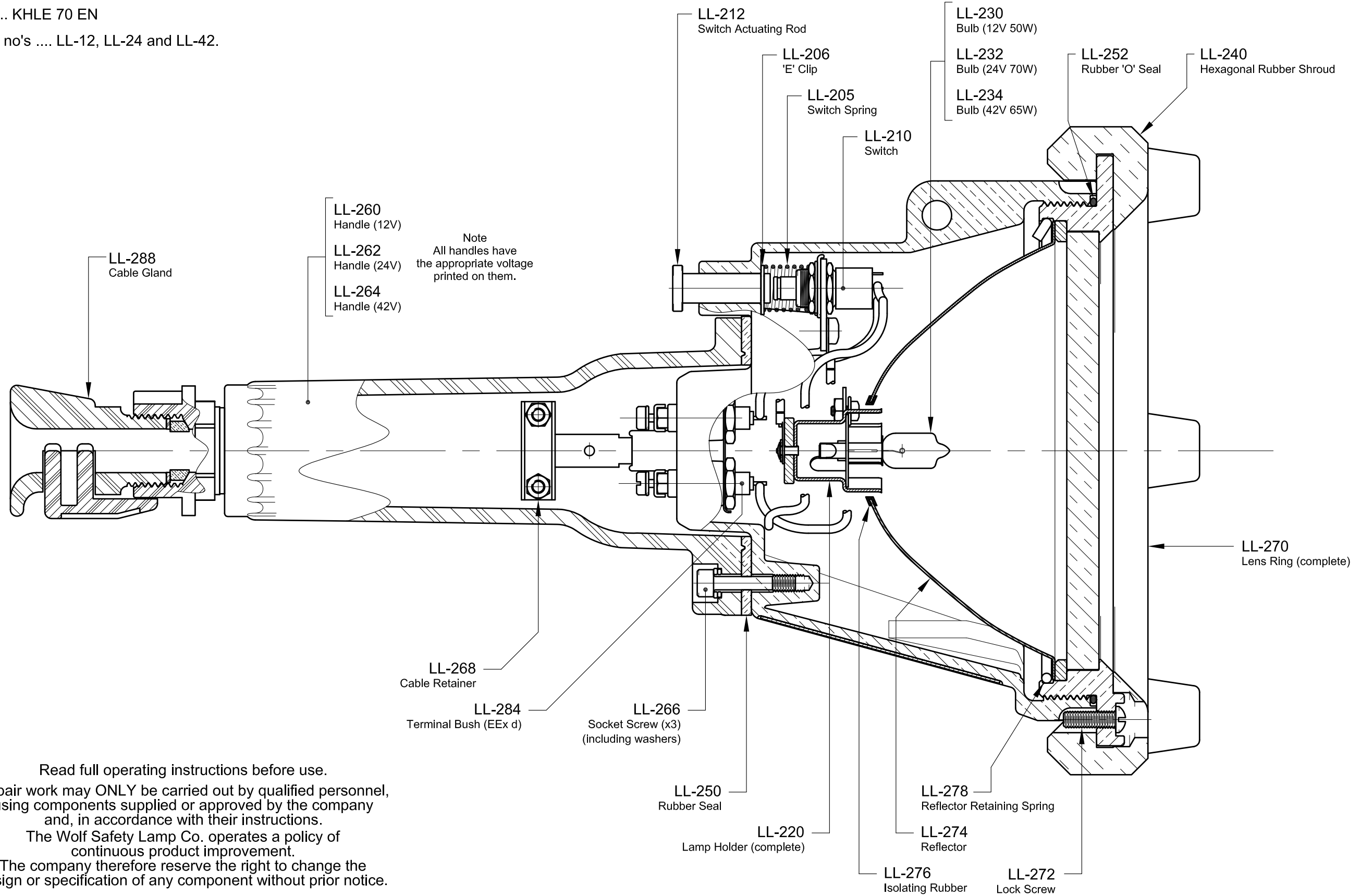

Read full operating instructions before use.  
 Repair work may ONLY be carried out by qualified personnel, using components supplied or approved by the company and, in accordance with their instructions.  
 The Wolf Safety Lamp Co. operates a policy of continuous product improvement.  
 The company therefore reserve the right to change the design or specification of any component without prior notice.

Höfer Ohl 12, 51645 Gummersbach Tel: 02261-92053-0  
Fax: 02261-92053-29  
e-mail: [SBE@SBE-Schrader.de](mailto:SBE@SBE-Schrader.de)  
<http://www.SBE-Schrader.com>

## EC-Declaration of Conformity

The cable Handlamp meets all relevant provisions of the 94/9/EC (ATEX Equipmet) Directive, by virtue of the issued EC type examination certificate, demonstrating compliance with all relevant harmonised standards and essential health and safety requirements.

Also complies with EMC Directive 2004/108/EC.

## EC- Manufacturer-Declaration

According to Guideline Machinery 98/37/EC and EMV-Guideline 2004/108/EC

Manufacturer: SBE Schrader Bergbau Elektrik - GmbH  
Adress: Höfer Ohl 12  
51645 Gummersbach

Product description:: Cable Handlamp  
type : KHLE 70-\*\*V-\*\*W

EC Type examination certificate: BVS 03 ATEX E 279

Kennzeichnung



II 2G EEx de IIC T3/T4

### Notified Body::

DEKRA EXAM GmbH, Notified body number: 0158

Carl-Beyling-Haus  
Dinnendahlstraße 9  
44809 Bochum

The equipment is suitable to be used at a fixed location or as a portable hand-tool in hazardous areas and installations.

**The insulation resistance of the handlamp KHLE is 100kOhm contrary to EN 60079-17 – 4.12.9**

Harmonised standarts applied:

EN 50014:1997+A1-A2 status of production according EN 60079-0 :2006  
EN 50018:2000+A1 status of production according EN 60079-1 :2007  
EN 50019:2000 status of production according EN 60079-7 :2007

Harmonised standarts applied for EMC-Guideline 2004/108/EG, specially

:

EN 61000-6-3 :2007  
EN 61000-6-2 :2005  
EN 61000-3-2 :2006

**SBE-GmbH**

Gummersbach, 05/2009

**SBE** SCHRADER  
BERGBAU  
ELEKTRIK **GmbH**

Sign:   
Höfer Ohl 12  
51645 Gummersbach  
☎ 02261/92053-0

This declaration confirms to meet the requirements of the above mentioned directives, however does not include a guarantee under all circumstances. Adhering to the safety-instructions, provided with the products or in manuals, are mandatory.

If there are any modifications made to the product and/or its components, without the explicit approval of the manufacturer, the above declaration is no longer valid.