

Vulcan + Range-Taking Cable Cleat Data Sheet

Vulcan + cable cleats are available for trefoil, single, quad and bundled cable applications where moderate levels of short circuit withstand are required. The unique patented compact design allows easy installation where space is limited. Manufactured in type 316L stainless steel, they offer ultimate protection against the harshest environmental conditions. The cleats are supplied with an M10 stainless steel clamping bolt, an M10 stainless steel Flange nut and a Low Smoke & Fume Zero Halogen Polymeric Head Retainer (MDS01 Data Sheet*).

To protect and cushion the cables during short circuit conditions, the cleat comes with an integral Low Smoke & Fume Zero Halogen Polymeric liner and removable base pad (MDS01 Data Sheet*).

Recommended fixing methods include using either one or two M10 bolts (available as extras). A ProTect Intermediate Strap (details from Ellis Patents) can be fitted between wider spaced cleats for more economical installation.

* Material Data Sheet MDS01 is available upon request.

UK Patent GB 236 1029

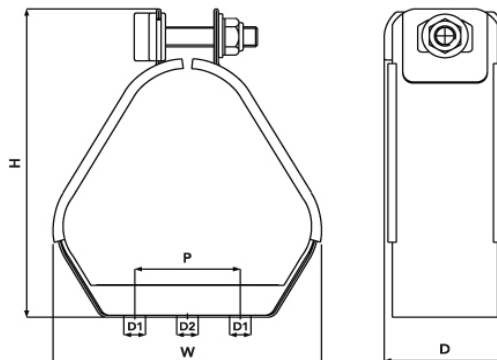

Selection Table for Trefoil & Single Application

Part No	Trefoil Cable Range		Single Cable Range		Dimensions					Weight g
	Min Dia. mm	Max Dia. mm	Min Dia. Mm	Max Dia. mm	W(max) mm	H(max) mm	D mm	P mm	Base Holes	
VRT+00	19	24	30	42	60	93	54	n/a	1 x M10	251
VRT+01	23	28	38	50	63	98	54	n/a	1 x M10	258
VRT+02	27	32	43	58	72	106	54	n/a	1 x M10	269
VRT+03	30	35	49	64	79	112	54	n/a	1 x M10	279
VRT+04	33	38	55	70	85	118	54	n/a	1 x M10	284
VRT+05	36	42	58	75	96	125	54	n/a	1 x M10	319
VRT+06	40	46	63	84	105	133	54	n/a	1 x M10	331
VRT+07	44	50	73	90	112	140	54	n/a	1 x M10	391
VRT+08	48	55	83	100	121	149	54	n/a	1 x M10	405
VRT+09	51	58	86	104	126	154	54	n/a	1 x M10	411
VRT+10	55	62	88	110	134	162	54	50	3 x M10	442
VRT+11	59	66	90	115	143	170	54	50	3 x M10	453
VRT+12	63	70	100	125	152	177	54	50	3 x M10	460
VRT+13	67	74	107	132	161	185	54	75	3 x M10	524
VRT+14	71	78	120	145	169	192	54	75	3 x M10	536
VRT+15	74	82	125	150	176	199	54	75	3 x M10	542
VRT+16	77	85	132	153	183	205	54	75	3 x M10	544
VRT+17	81	89	136	156	190	216	54	75	3 x M10	618
VRT+18	85	93	139	159	200	225	54	75	3 x M10	628
VRT+19	89	97	142	162	200	235	54	75	3 x M10	637
VRT+20	93	101	150	170	215	240	54	75	3 x M10	646

Selection Table for Quad Cable Application

Part No	Quad Cable Range		Dimensions					Weight g
	Min Dia. mm	Max Dia. mm	W(max) mm	H(max) mm	D mm	P mm	Base Holes	
VRQ+01	23	25	68	110	54	n/a	1 x M10	284
VRQ+02	26	27	70	113	54	n/a	1 x M10	286
VRQ+03	28	32	80	128	54	n/a	1 x M10	318
VRQ+04	33	42	103	148	54	n/a	1 x M10	378
VRQ+05	43	47	120	165	54	n/a	1 x M10	452
VRQ+06	48	50	121	170	54	n/a	1 x M10	467
VRQ+07	51	57	140	190	54	50	3 x M10	486
VRQ+08	58	63	150	200	54	50	3 x M10	499
VRQ+09	64	70	170	218	54	75	3 x M10	581

Testing Information

Vulcan + Cleats have been tested in line with the International Standard of 'Cable Cleats for for Electrical Installations' IEC 61914:2009. Typical Results are detailed below:

Properties	IEC 61914:2009 Classification Clause	Units / Classification	Vulcan + Trefoil Test Data	Vulcan + Single Test Data
Cleat Type	6.1, 6.1.3	Composite	-	-
Impact Resistance	6.3, 6.3.5, 9.2	Very Heavy Classification (5.0kg @ 400mm)	Pass	Pass
Resistance to Electro Mechanical Force <i>(Undertaken at Damstra Laboratories NL)</i>	6.4, 6.4.3, 9.5	kA @ 300mm Centres M10 Fixings <i>(Withstanding one short circuit)</i>	132 (Peak) <i>(Report No. PDL-06.037.1)</i>	Refer to Ellis Patents for further details.
Resistance to Electro Mechanical Force <i>(Undertaken at Damstra Laboratories NL)</i>	6.4, 6.4.4, 9.5	kA @ 600mm Centres M10 Fixings <i>(Withstanding more than one short circuit)</i>	104 (Peak) <i>(Report No. PDL-07.161.2.1)</i>	Refer to Ellis Patents for further details.
Temperature for Permanent Application	6.2	°C	-40 to 60	-40 to 60
Needle Flame	10.0, 10.1	Application Time (seconds)	>120	>120
Lateral Load Test	9.3	Newtons (N)	3000	5830
Axial Load Test	9.4	Newtons (N)	1000	280



VRT+06 4CG8



VRQ+03 4CG8



American Bureau of Shipping
Type Approval



**London
Underground**

Vulcan VRT+ Cable Cleats are compliant with the requirements of London Underground Standard 1-085. Product Register No. 361