

Raychem High Voltage Cable Accessories up to 170 kV

Raychem
from TE Connectivity

About TE Energy High Voltage Products

Page 4

About TE Energy High Voltage Cable Accessories

Page 6

Raychem Outdoor Terminations
OHVT-C (Composite)

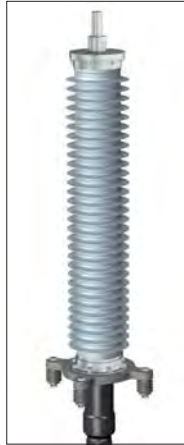

Voltage	Page
72 kV	9
145 kV	10
170 kV	11

Raychem Outdoor Terminations
OHVT-P (Porcelain)



Voltage	Page
72 kV	13
123 kV	14
145 kV	15

Raychem Dry Compact Switchgear
Terminations PHVS



Voltage	Page
72 kV	28
145 kV	28

Raychem Dry Compact Transformer
Terminations PHVT



Voltage	Page
72 kV	30
145 kV	31

Raychem Heat-shrinkable Joints for
Polymeric Cables



Voltage	Page
52 kV	36
72 kV	37

Raychem One Piece Joint



Voltage	Page
145 kV	39

Raychem Dry Outdoor Terminations (plugable) OHVT-D

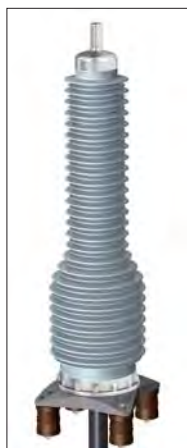

Voltage 145 kV
Page 17

Raychem Heat-shrinkable Terminations IHVT-H/OHVT-H

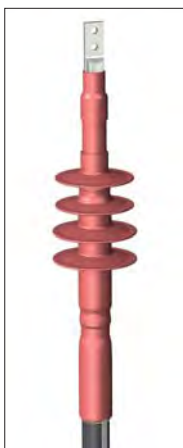

Voltage
52 kV indoor 19
52 kV outdoor 20
72 kV indoor 21
72 kV outdoor 22
72 kV long creepage 23
123 kV outdoor 24

Raychem Heat-shrinkable Terminations for Filter Cables DC FCEV

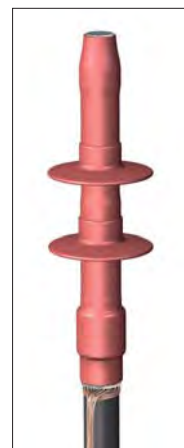

Voltage
111 kV 26
150 kV 26

Raychem Switchgear Terminations SHVT



Voltage 145 kV
Page 33

Raychem Transformer Terminations THVT



Voltage 145 kV
Page 34

Raychem Three Piece Joint



Voltage 145 kV
Page 41

Add-On Kits for HV Cable Accessories



Product
Arcing Horn 42
Lifting Device 42
Blind Plug 43
PHVX Accessories 43
HV Connectors 44
Cable Clamps 47
Fibre-Optic Kit 48

Raychem Link Boxes



Product
For single core cables 51
For concentric (coax) cables 51



Our transmission line and substation competence

TE Energy High Voltage Products

We offer a broad range of reliable and cost-effective, high-performance solutions including full customer support. This covers application and engineering assistance, hands-on field training and continuous after-sales support. Expertise from over 60 years in materials science, product design and process engineering goes into the creation, development, manufacturing and marketing of our products.

Our competitive advantages are well recognized in the market:

- Customer-focused organization
- Driven by innovation and technology
- Extensive product range
- Multiple market-segment presence
- Industrial leadership and expertise
- Structural and financial strength

Our wide range of reliable and cost-effective solutions is continuously expanding through research-driven product development.

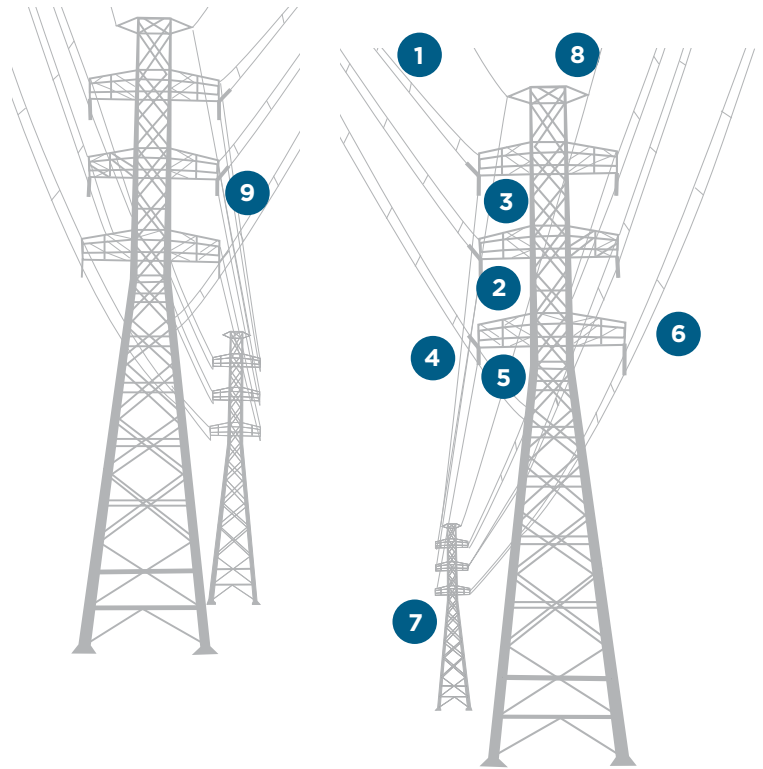

Transmission lines

- 1 Spacer-dampers
- 2 Dampers
- 3 Rigid spacers
- 4 Compression fittings
- 5 Hardware fittings
- 6 Suspension clamps
- 7 Mechanical dead ends
- 8 Earthing and grounding systems
- 9 Insulation and protection products

Substations

- 10 Connectors - up to 800kV range
- 11 HVDC applications
- 12 Station fittings
- 13 Earthing and grounding systems
- 14 Hollow core insulators
- 15 Cable terminations
- 16 Cable joints
- 17 Insulation enhancement system
- 18 Accessories for insulated MV/HV cables
- 19 Porcelain insulators
- 20 Vacuum resin impregnated fibre reinforced components
- 21 Surge arresters and surge counters

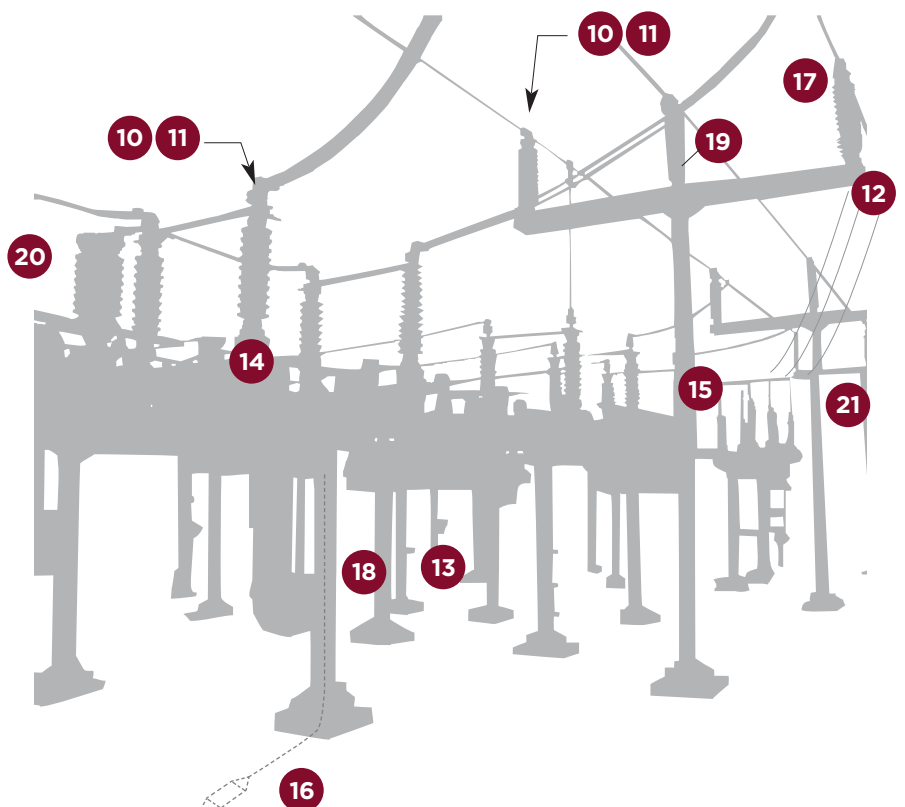

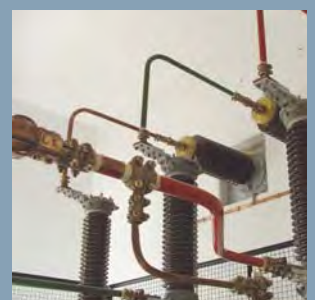

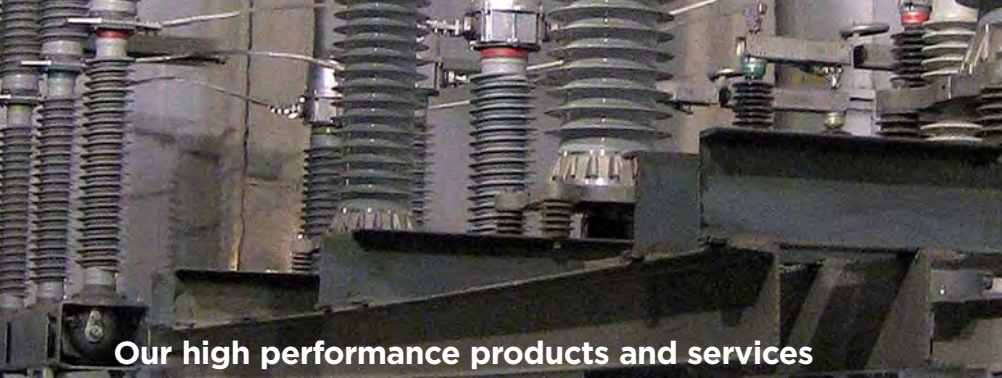

Our high performance products and services

TE Energy High Voltage Cable Accessories

Experience

We are focused on development, manufacturing of cable accessories and execution of projects providing reliable operation of electric power systems.

Many of the world's leading enterprises apply our cable accessories which are developed for the long-term operation in the most severe conditions of indoor and outdoor maintenance in any climatic zones and high pollution locations. Our products have a very high reliability index which warrants saving of customers capital outlays. We use experience accumulated from more than 40 years in materials science, development of new technologies, and intensive study of customers needs. We constantly improve our production technology and the quality of our products while paying attention to customers increasing requirements.

Our products passed all relevant tests in independent test labs in order to comply with quality requests of International Standards like IEC, IEEE.

TE Energy has technical support centers where customers can get professional assistance. Our specialists are always ready to find solutions for any specific issue of any enterprise.

Installation, Training and Supervision

TE Energy is an independent supplier of HV cable accessories. We provide our products worldwide to

- utilities with their own installation crews
- contractors providing installation services to utilities and industrial customers
- cable manufacturers

We are able to offer the following services:

- Installations (accessories only)
- Trainings (on-site and in-house)
- Supervisions

Installations

TE Energy has well-trained and experienced jointers who are able to carry out installation at construction sites. Usually they are supported by local assistance provided by the contractor or the local utility. If there are no trained jointers available locally, ordering installation services from us is the first choice.

Training

Jointers with 5 years or more experience in HV cable preparation may be trained on-site during an installation. Less experience jointers should be first trained in our labs. In both cases, well-experienced supervisors demonstrate how to install our products to ensure the high performance expected is maintained over the whole life time of our products. At the end of the training the jointers will be able to carry out installations without or at least with a minimum of help provided by our supervisors.

Supervision

Jointers, who have been trained by TE Energy supervisors prior to an installation but haven't yet had sufficient on-site experience in installing TE Energy accessories, may need the help of a supervisor on-site. We recommend ordering this service for the first installations. This ensures that all accessories are installed according to the instructions provided with the accessories.





Raychem Outdoor Terminations OHVT-C (Composite)

Application

The termination is designed for voltage classes up to 170 kV and to operate under severe environmental conditions. Polymeric insulated cables of various designs can be adopted with respect to shielding and metal sheath. Composite housings with different creepage lengths up to 50 mm/kV are available for the most common and also extreme pollution levels according to IEC 60071-1, IEC 60071-2 and IEEE-1313.1.

Features

- Pressure-tight and light weight composite housing
- Pre-fabricated and factory-tested Si-rubber stress cone
- Torque-controlled conductor bolt
- No special tools required to install the termination
- Si-oil filling without preheating
- Isolated base plate for sectionalization
- Fittings made of corrosion-resistant alloy
- Type tested according to IEC 60840 and IEEE 48 standards

Construction and Design

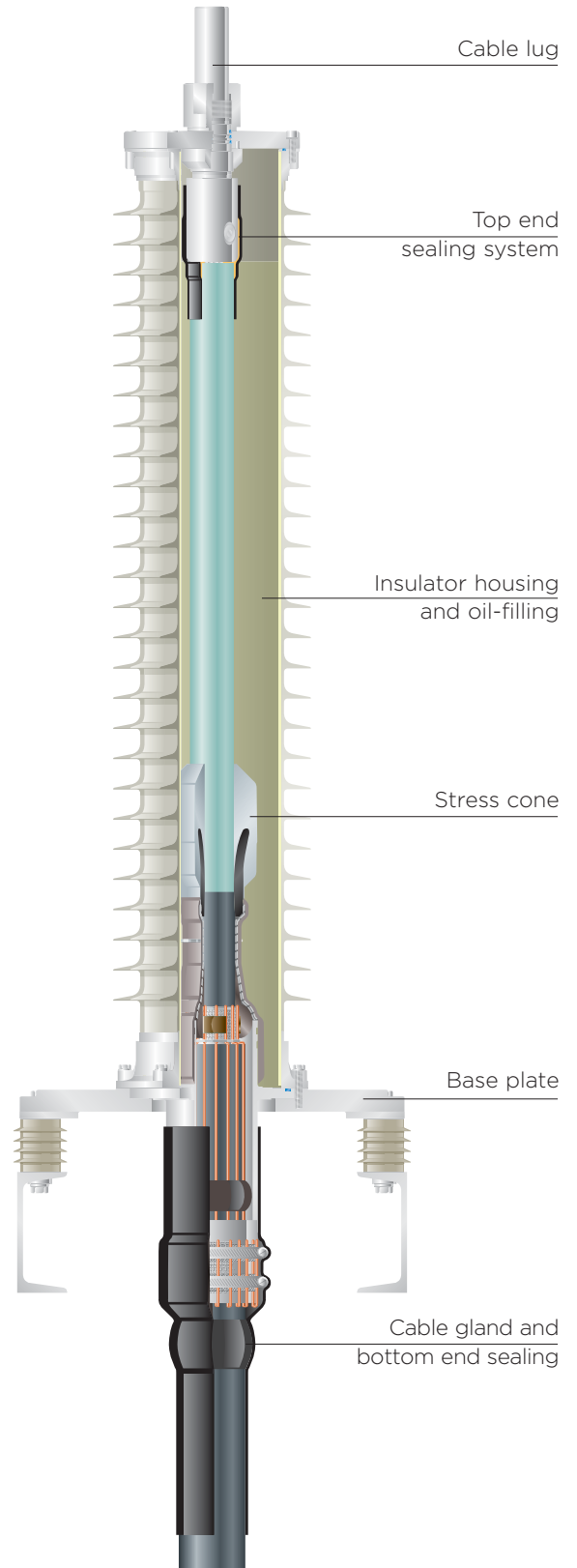
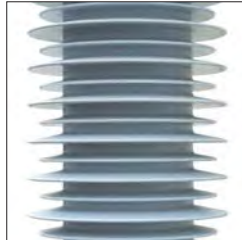

Max. operating voltage U_m (kV)	72.5	123	145	170
Standards	IEC 60840 IEC 60815	IEC 60840 IEC 60815	IEC 60840 IEC 60815	IEC 60840 IEC 60815
Rated voltage U (kV)	60 - 69	110 - 115	132 - 138	150 - 161
Rated lightning impulse withstand voltage (BIL) (kV)	325	550	650	750
Partial discharge measurement (pC)	< 5	< 5	< 5	< 5

Raychem Outdoor Terminations OHVT-72C

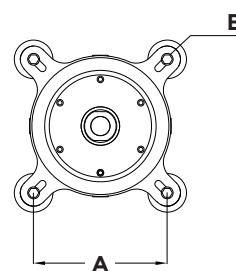
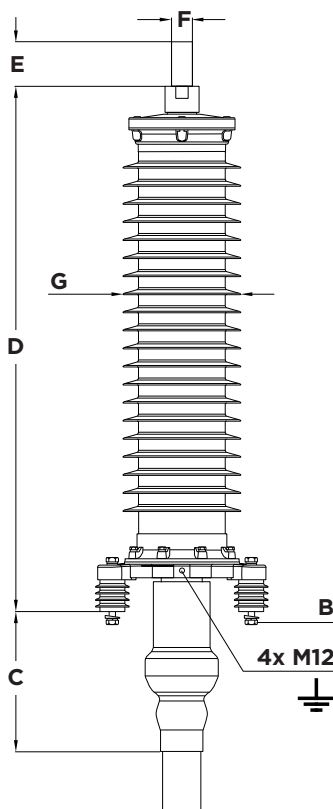

Technical data

Product description	Conductor cross section (mm ²)	Diameter over cable insulation (prepared) (mm)	max. diameter over outer cable sheath (mm)	minimal creepage distance (mm)
OHVT-72C (-2A)	95 - 2500	34 - 97	110	2164
OHVT-72C (-2B)	95 - 2500	34 - 97	110	2383

Dimensions

Product description	A (mm)	B	C (mm)	D (mm)	E (mm)	F (mm)	G (mm)
OHVT-72C (-2A)	345	M16	350	1276	100/130	30/40/50	294
OHVT-72C (-2B)	345	M16	350	1072	100/130	30/40/50	304

Raychem Outdoor Terminations OHVT-145C

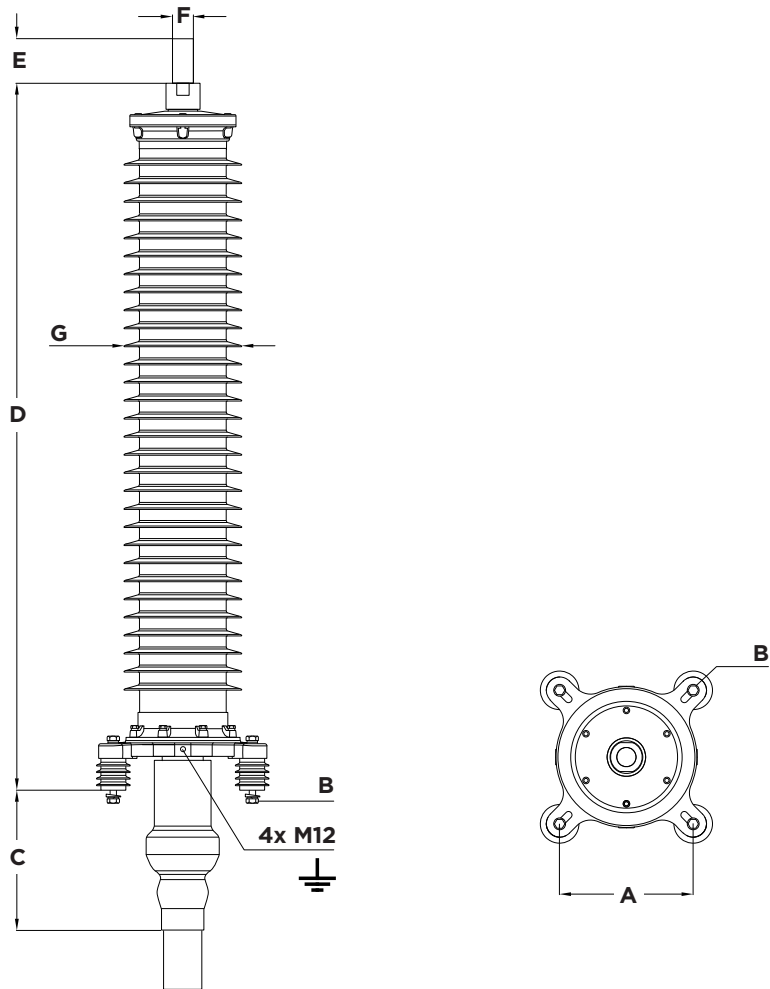
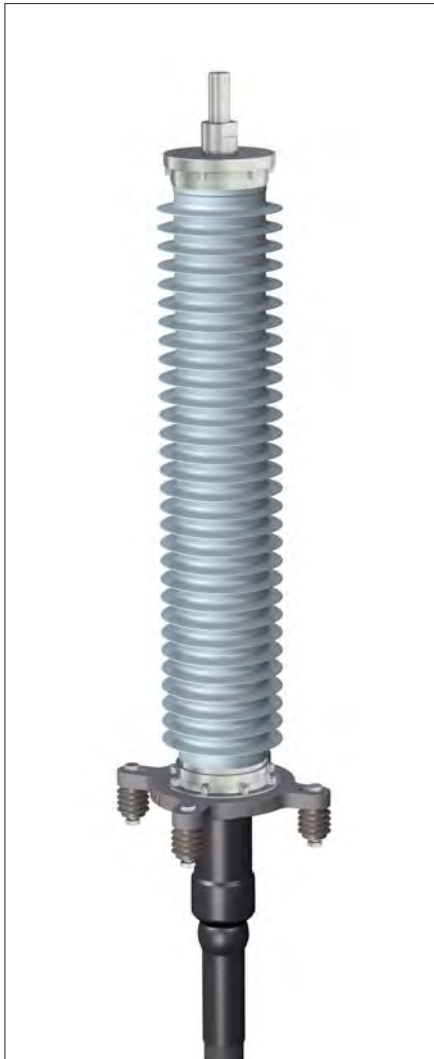

Technical data

Product description	Conductor cross section (mm ²)	Diameter over cable insulation (prepared) (mm)	max. diameter over outer cable sheath (mm)	minimal creepage distance (mm)
OHVT-145C (-2A)	95 - 2500	34 - 97	110	3392
OHVT-145C (-3A)	95 - 2500	34 - 97	110	3829
OHVT-145C (-4A)	95 - 2500	34 - 97	110	4684
OHVT-145C (-4B)	95 - 2500	34 - 97	110	6100
OHVT-145C (-4C)	95 - 2500	34 - 97	110	8047

Dimensions

Product description	A (mm)	B	C (mm)	D (mm)	E (mm)	F (mm)	G (mm)
OHVT-145C (-2A)	345	M16	350	1771	100/130	30/40/50	294
OHVT-145C (-3A)	345	M16	350	1951	100/130	30/40/50	294
OHVT-145C (-4A)	345	M16	350	1696	100/130	30/40/50	304
OHVT-145C (-4B)	345	M16	350	2080	100/130	30/40/50	304
OHVT-145C (-4C)	345	M16	350	2608	100/130	30/40/50	304

Raychem Outdoor Terminations OHVT-170C

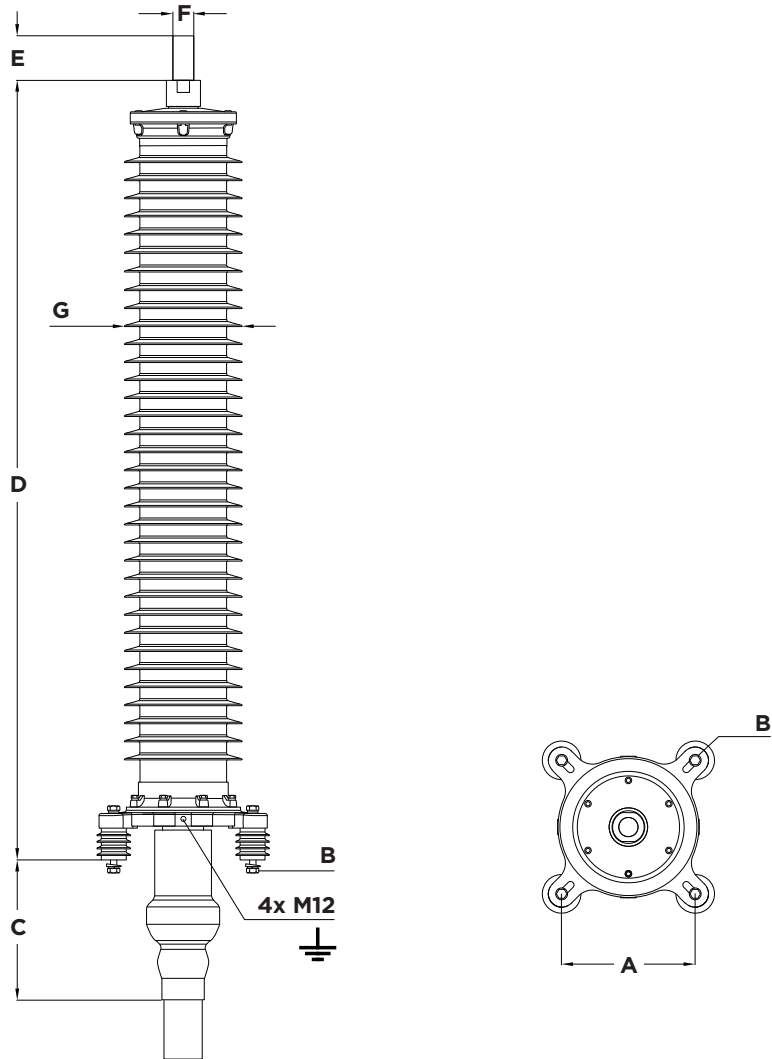
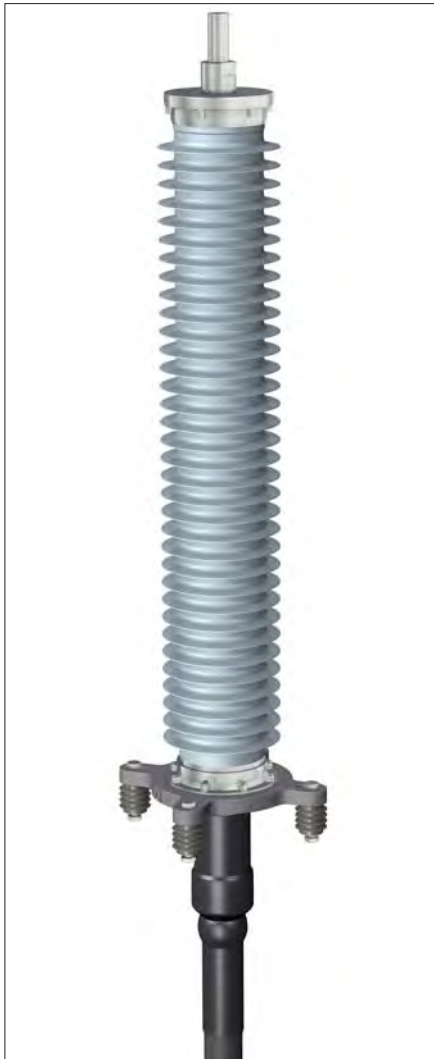

Technical data

Product description	Conductor cross section (mm ²)	Diameter over cable insulation (prepared) (mm)	max. diameter over outer cable sheath (mm)	minimal creepage distance (mm)
OHVT-170C (-1A)	95 - 2500	43 - 108	135	3829
OHVT-170C (-3A)	95 - 2500	43 - 108	135	4273
OHVT-170C (-4A)	95 - 2500	43 - 108	135	5272
OHVT-170C (-4B)	95 - 2500	43 - 108	135	5746
OHVT-170C (-4C)	95 - 2500	43 - 108	135	9436

Dimensions

Product description	A (mm)	B	C (mm)	D (mm)	E (mm)	F (mm)	G (mm)
OHVT-170C (-1A)	345	M16	350	2028	100/130	30/40/50	345
OHVT-170C (-3A)	345	M16	350	2224	100/130	30/40/50	345
OHVT-170C (-4A)	345	M16	350	2614	100/130	30/40/50	345
OHVT-170C (-4B)	345	M16	350	2056	100/130	30/40/50	355
OHVT-170C (-4C)	345	M16	350	2854	100/130	30/40/50	355

Raychem Outdoor Terminations OHVT-P (Porcelain)

Application

The termination is designed for voltage classes up to 145 kV and to operate under severe environmental conditions. Polymeric insulated cables of various designs can be adopted with respect to shielding and metal sheath.

Features

- Well-proven porcelain housing
- Pre-fabricated and factory-tested Si-rubber stress cone
- Torque-controlled conductor bolt
- H/S components used for sealing
- No special tools required to install the termination
- Si-oil filling (filling from the top)
- Isolated base plate for sectionalization
- Fittings made of corrosion resistant alloy
- Type tested according to IEC 60840 and IEEE 48 standards

Construction and Design

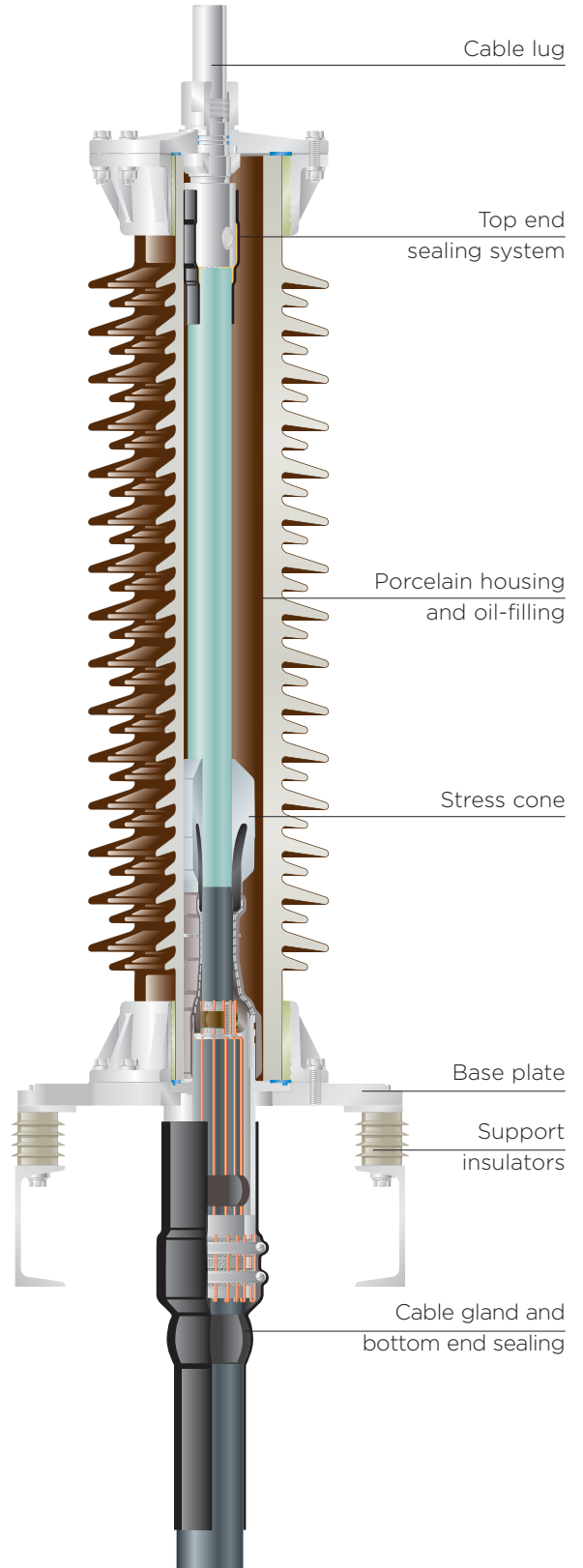

Max. operating voltage U_m (kV)	72.5	123	145
Standards	IEC 60840 IEC 60815	IEC 60840 IEC 60815	IEC 60840 IEC 60815
Rated voltage U (kV)	60 - 69	110 - 115	132 - 138
Rated lightning impulse withstand voltage (BIL) (kV)	325	550	650
Partial discharge measurement (pC)	< 5	< 5	< 5

Raychem Outdoor Terminations OHVT-72P

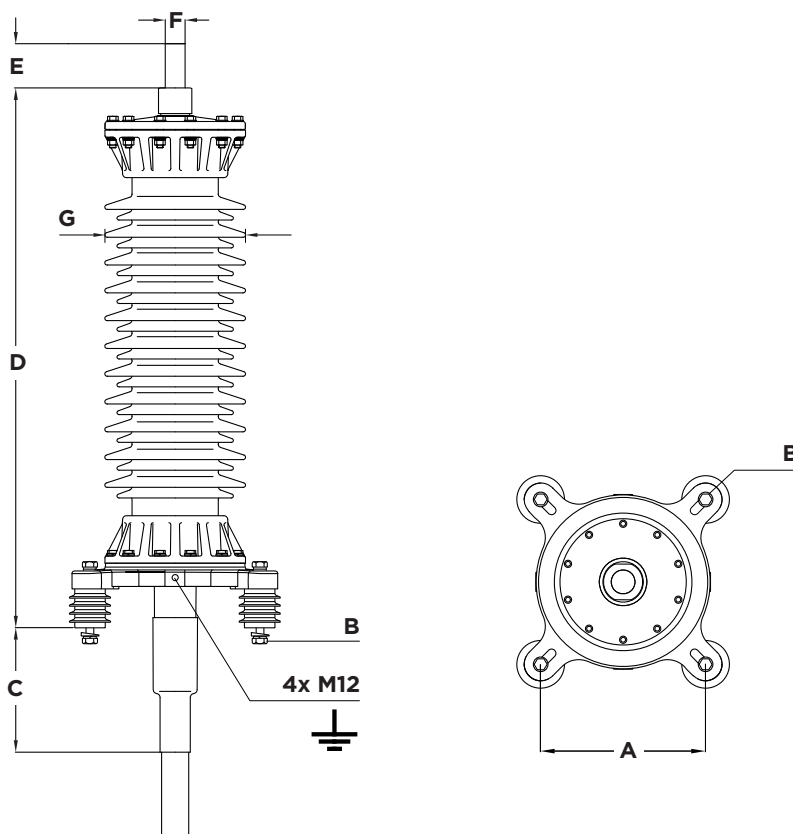

Technical data

Product description	Conductor cross section (mm ²)	Diameter over cable insulation (prepared) (mm)	max. diameter over outer cable sheath (mm)	minimal creepage distance (mm)
OHVT-72P (-2A)	95 - 1200	34 - 74	110	2350

Dimensions

Product description	A (mm)	B	C (mm)	D (mm)	E (mm)	F (mm)	G (mm)
OHVT-72P (-2A)	345	M16	350	1245	100/130	30/40/50	360

Raychem Outdoor Terminations OHVT-123P

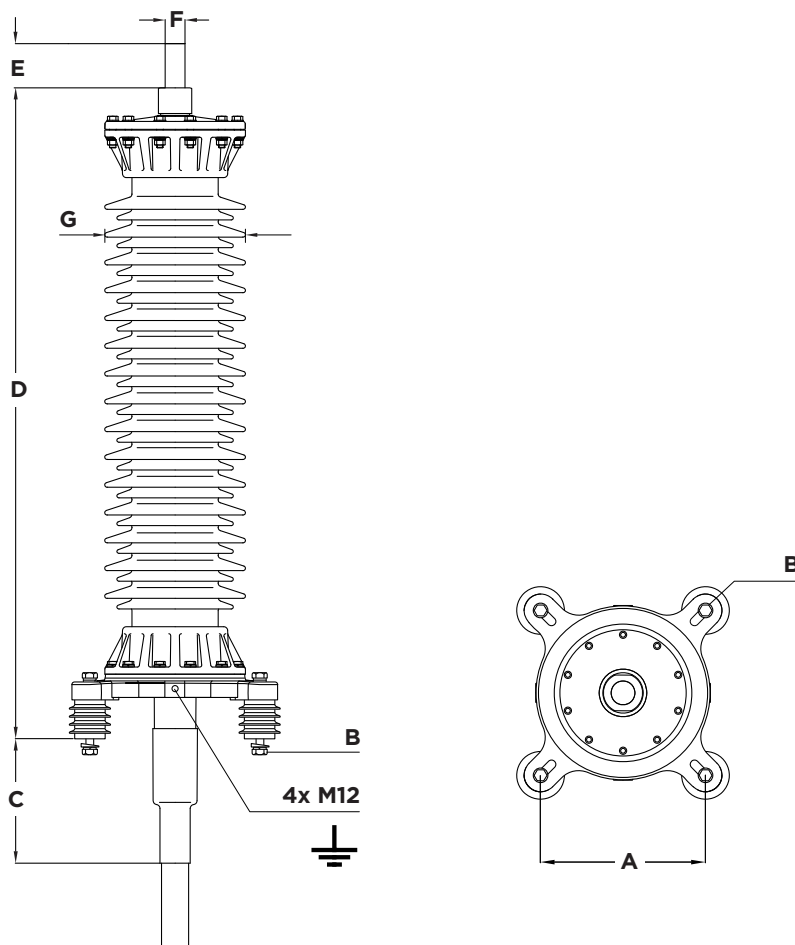

Technical data

Product description	Conductor cross section (mm ²)	Diameter over cable insulation (prepared) (mm)	max. diameter over outer cable sheath (mm)	minimal creepage distance (mm)
OHVT-123P (-4B)	95 - 1200	34 - 74	110	3910

Dimensions

Product description	A (mm)	B (mm)	C (mm)	D (mm)	E (mm)	F (mm)	G (mm)
OHVT-123P (-4B)	345	M16	350	1830	100/130	30/40/50	385

Raychem Outdoor Terminations OHVT-145P

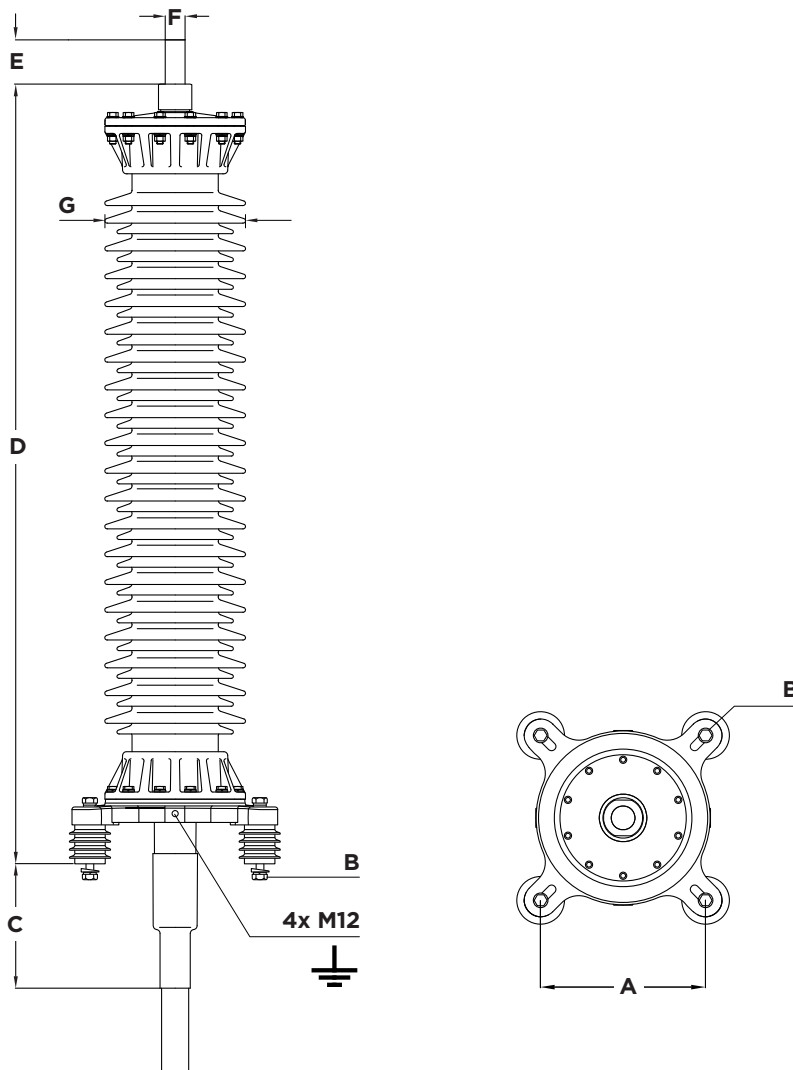

Technical data

Product description	Conductor cross section (mm ²)	Diameter over cable insulation (prepared) (mm)	max. diameter over outer cable sheath (mm)	minimal creepage distance (mm)
OHVT-145P (-4A)	95 - 800	34 - 74	110	4300

Dimensions

Product description	A (mm)	B	C (mm)	D (mm)	E (mm)	F (mm)	G (mm)
OHVT-145P (-4A)	345	M16	350	2046	100/130	30/40/50	360

Raychem Dry Outdoor Terminations (plugable) OHVT-D

Application

The dry self-supporting termination is designed for voltage class 145 kV and operation under severe environmental conditions. It is free from any insulating liquid or gel. Polymeric insulated cables of various designs can be adopted with respect to shielding and metal sheath. The termination is easily separable and consists of a plug-in part and an epoxy resin insulator protected with a directly moulded silicone shed housing. Due to the short cable cut-back dimensions of the plug-in, the time required to install the termination is very short and can be further reduced by pre-installing the plug-in on the shop floor. The plug-in is similar to the plug-in used with our dry switchgear/transformer termination.

Features:

- Dry interface, no oil-filling
- Self-supporting
- Pre-fabricated and factory tested silicone-rubber stress cone
- Torque-controlled multi-contact conductor bolt
- Fast and simple installation combining GIS plug-in technology with polymeric insulators
- No special tools required to install the termination
- Isolated cable gland for sectionalization
- Type tested according to IEC 60840

Construction and Design

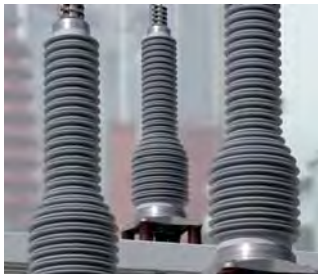
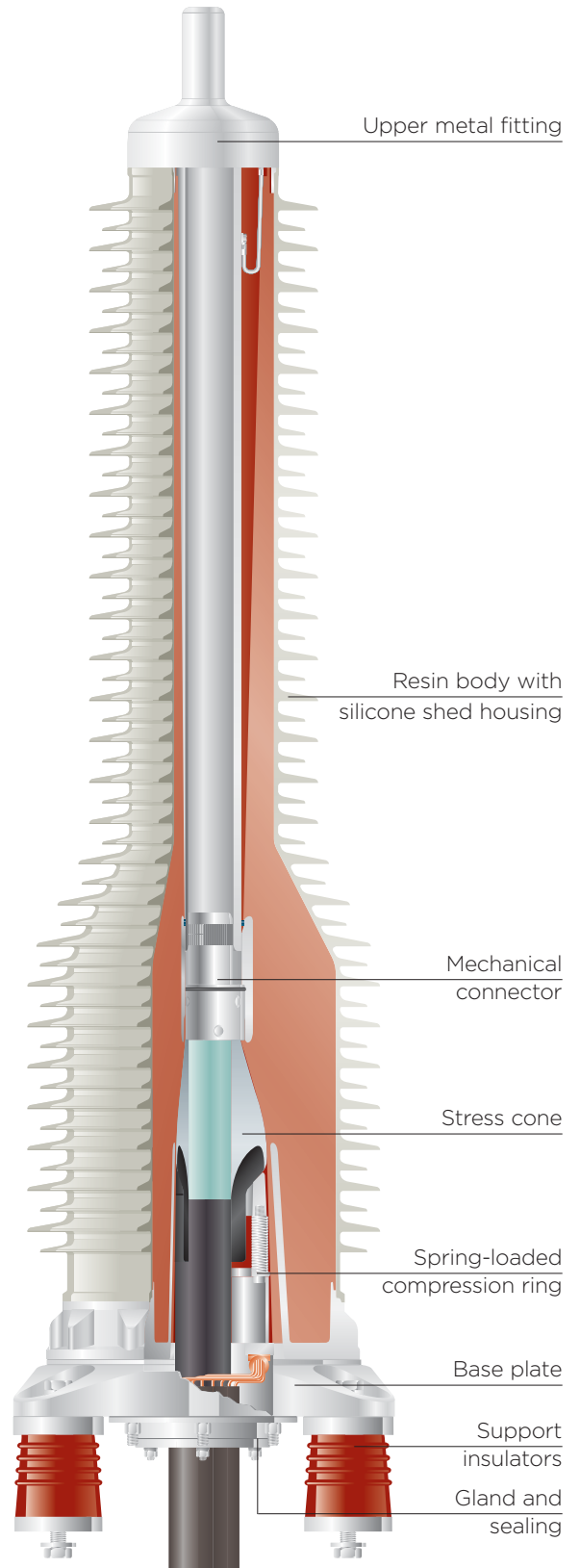

Max. operating voltage U_m (kV)	123	145
Standards	IEC 60840 IEC 60815	IEC 60840 IEC 60815
Rated voltage U (kV)	110 - 115	132 - 138
Rated lightning impulse withstand voltage (BIL) (kV)	550	650
Partial discharge measurement (pC)	< 5	< 5

Raychem Dry Outdoor Terminations (pluggable) OHVT-D

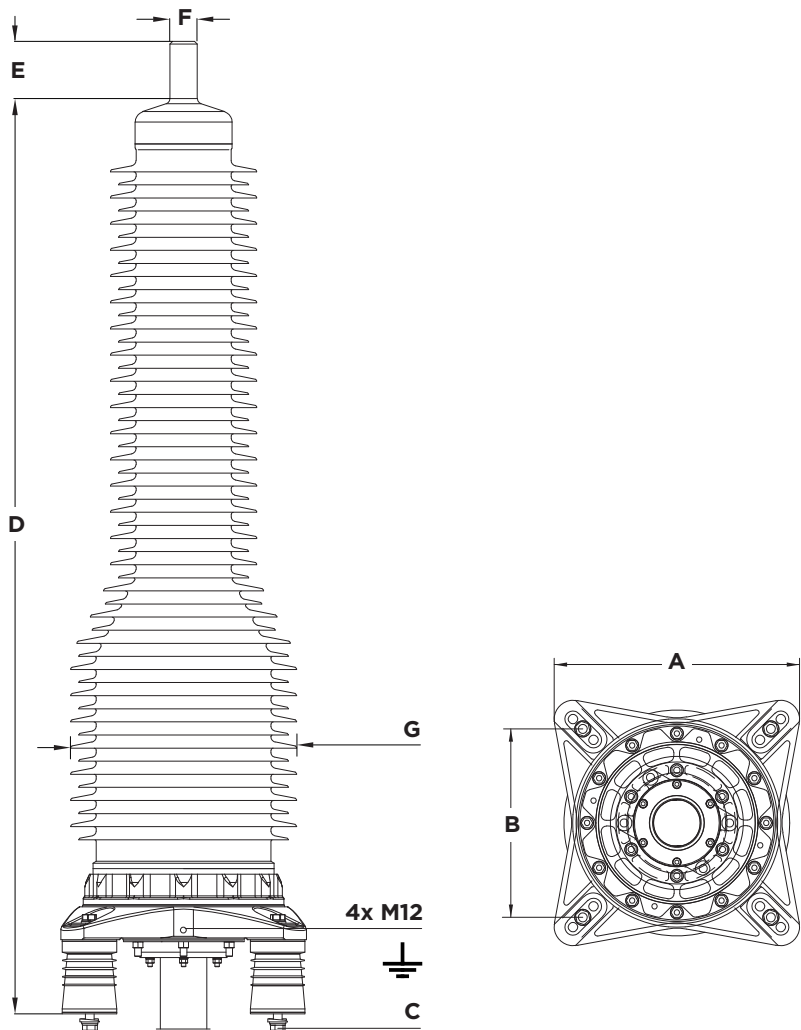
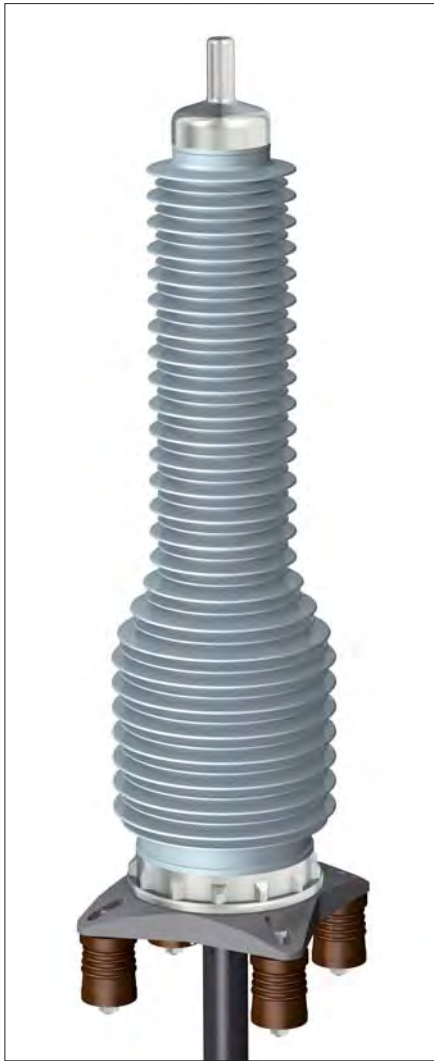

Technical data

Product description	Conductor cross section (mm ²)	Diameter over cable insulation (prepared) (mm)	max. diameter over outer cable sheath (mm)	minimal creepage distance (mm)
OHVT-145D	95 - 1200	34 - 78	99	4680

Dimensions

Product description	A (mm)	B (mm)	C (mm)	D (mm)	E (mm)	F (mm)	G (mm)
OHVT-145D	450	345	M16	1783	100	50	410

Raychem Heat-Shrinkable Terminations IHVT-H/OHVT-H

Application

The TE Connectivity Raychem 52/72kV terminations are suitable for all climates, areas, and environments, even severely polluted areas, as well as for all installation conditions, including top feed installation.

Our heat shrink accessories have been used by utilities and industrial companies around the world for more than 35 years.

Features

- Compact and modular design
- Heat-shrinkable stress control sleeves
- Non-tracking, heat-shrinkable outer insulation
- Water- and corrosion-resistant
- Different creepage distances available
- Easy to install
- Suitable for compression and mechanical lugs
- No special or expensive tools
- Lightweight components
- Unlimited shelf life under normal storage conditions
- No oil or compound filling
- Reduced waste for disposal
- Tested in accordance with IEEE 48 and IEC 60840
- Manufactured according to ISO 9001 and ISO 14001



Construction and Design

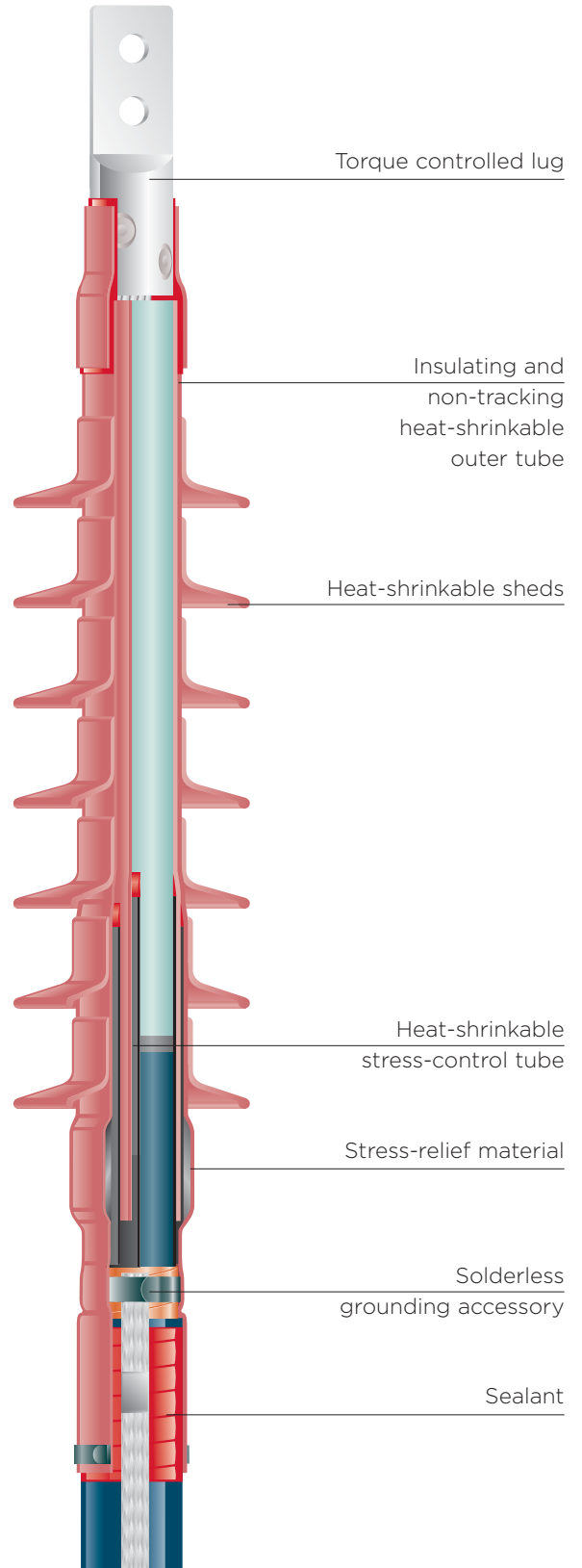

Max. operating voltage U_m (kV)	52	72.5	123
Standards	IEC 60840 IEC 60815	IEC 60840 IEC 60815	IEC 60840 IEC 60815
Rated voltage U (kV)	45 - 47	60 - 69	110 - 115
Rated lightning impulse withstand voltage (BIL) (kV)	250	325	325
Partial discharge measurement (pC)	< 5	< 5	< 5

Raychem Heat-Shrinkable Terminations IHVT-52H

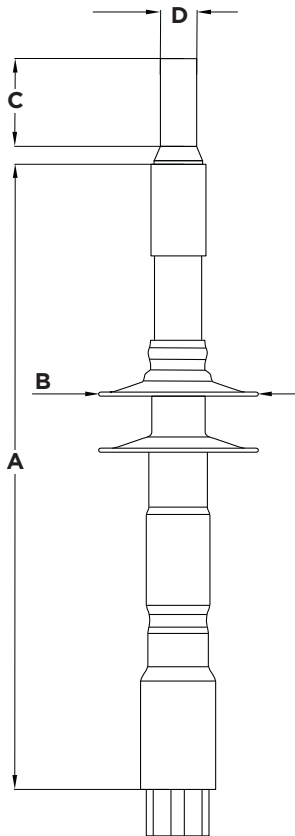
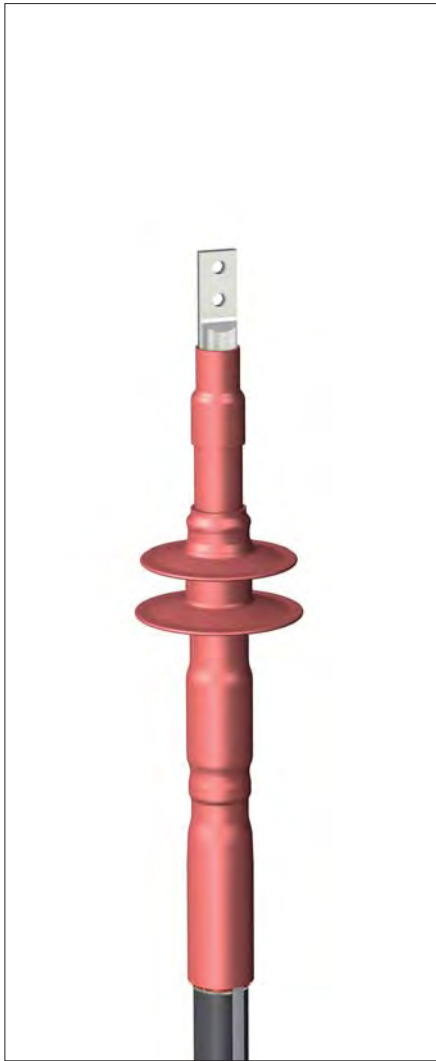

Technical data

Product description	Conductor cross section (mm ²)	Diameter over cable insulation (prepared) (mm)	max. Diameter over outer cable sheath (mm)	min. Creepage Distance (mm)
IHVT-52H	95 - 2500	30 - 45	60	1100
IHVT-52H		38 - 55	70	1100
IHVT-52H		48 - 65	80	1100
IHVT-52H		58 - 77	100	1100

Dimensions

Product description	A (mm)	B (mm)	C (mm)	D* (mm)
IHVT-52H	800	220	125	30/40/50
IHVT-52H	800	220	125	30/40/50
IHVT-52H	800	220	125	30/40/50
IHVT-52H	800	220	125	30/40/50

* different studs and pads are available on request

Raychem Heat-Shrinkable Terminations OHVT-52H

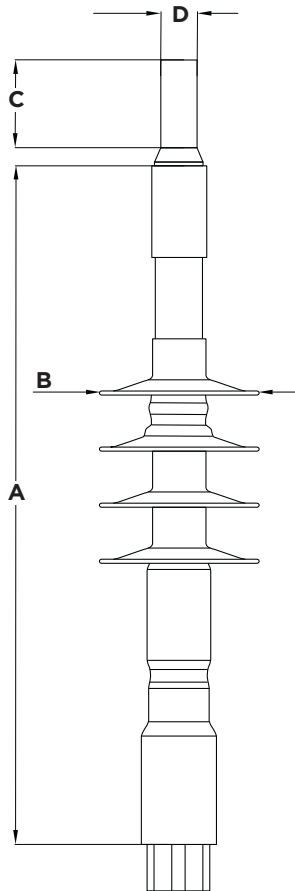
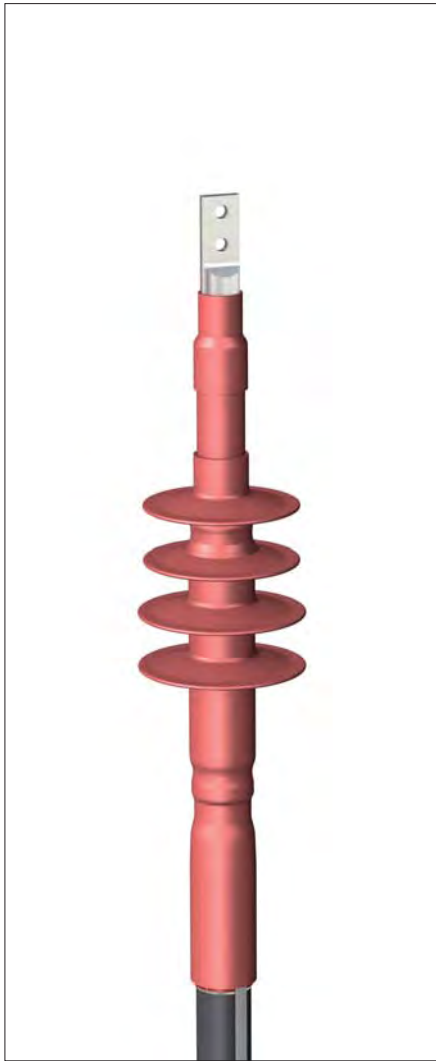

Technical data

Product description	Conductor cross section (mm ²)	Diameter over cable insulation (prepared) (mm)	max. Diameter over outer cable sheath (mm)	min. Creepage Distance (mm)
OHVT-52H	95 - 2500	30 - 45	60	up to 1540
OHVT-52H		38 - 55	70	up to 1540
OHVT-52H		48 - 65	80	up to 1540
OHVT-52H		58 - 77	100	up to 1540

Dimensions

Product description	A (mm)	B (mm)	C (mm)	D* (mm)
OHVT-52H	920	220	125	30/40/50
OHVT-52H	920	220	125	30/40/50
OHVT-52H	920	220	125	30/40/50
OHVT-52H	920	220	125	30/40/50

* different studs and pads are available on request

Raychem Heat-Shrinkable Terminations IHVT-72H

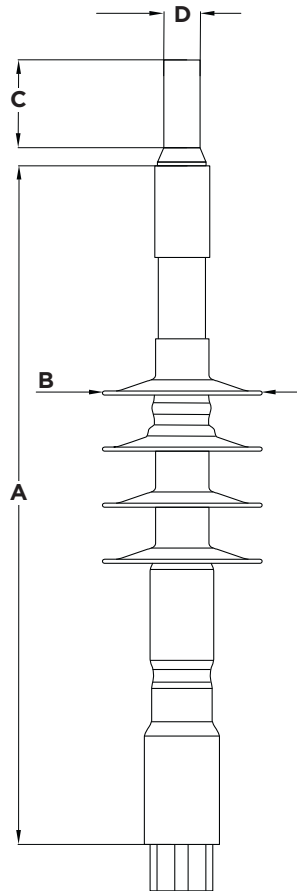
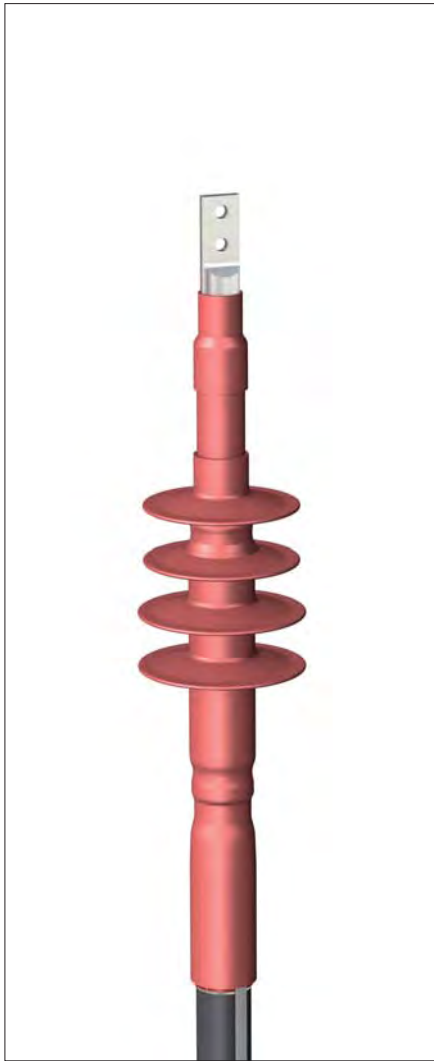

Technical data

Product description	Conductor cross section (mm ²)	Diameter over cable insulation (prepared) (mm)	max. Diameter over outer cable sheath (mm)	min. Creepage Distance (mm)
IHVT-72H		30 - 45	60	up to 1600
IHVT-72H		38 - 55	70	up to 1600
IHVT-72H	95 - 2500	48 - 65	80	up to 1600
IHVT-72H		58 - 77	100	up to 1600
IHVT-72H		70 - 86	110	up to 1600

Dimensions

Product description	A (mm)	B (mm)	C (mm)	D* (mm)
IHVT-72H	960	220	125	30/40/50
IHVT-72H	960	220	125	30/40/50
IHVT-72H	960	220	125	30/40/50
IHVT-72H	960	220	125	30/40/50
IHVT-72H	960	220	125	30/40/50

* different studs and pads are available on request

Raychem Heat-Shrinkable Terminations OHVT-72H

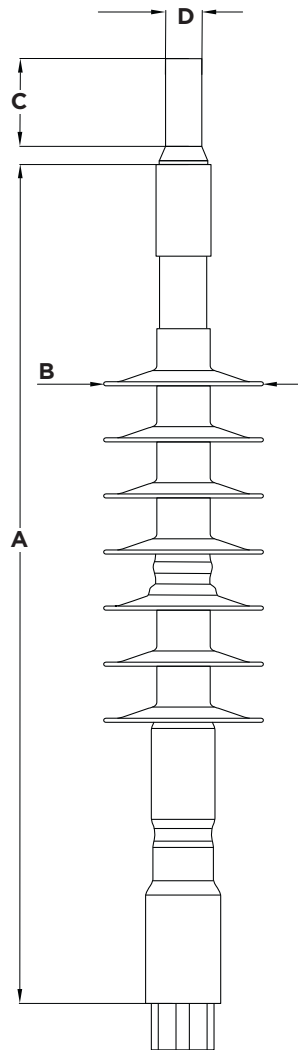
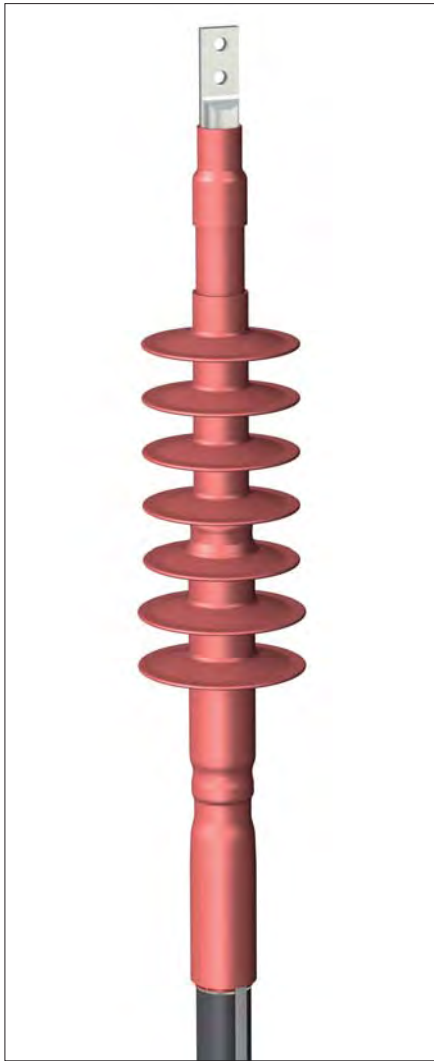

Technical data

Product description	Conductor cross section (mm ²)	Diameter over cable insulation (prepared) (mm)	max. Diameter over outer cable sheath (mm)	min. Creepage Distance (mm)
OHVT-72H	95 - 2500	30 - 45	60	up to 2300
OHVT-72H		38 - 55	70	up to 2300
OHVT-72H		48 - 65	80	up to 2300
OHVT-72H		58 - 77	100	up to 2300
OHVT-72H		70 - 86	110	up to 2300

Dimensions

Product description	A (mm)	B (mm)	C (mm)	D* (mm)
OHVT-72H	1200	220	125	30/40/50
OHVT-72H	1200	220	125	30/40/50
OHVT-72H	1200	220	125	30/40/50
OHVT-72H	1200	220	125	30/40/50
OHVT-72H	1200	220	125	30/40/50

* different studs and pads are available on request

Raychem Heat-Shrinkable Terminations LHVT-72H

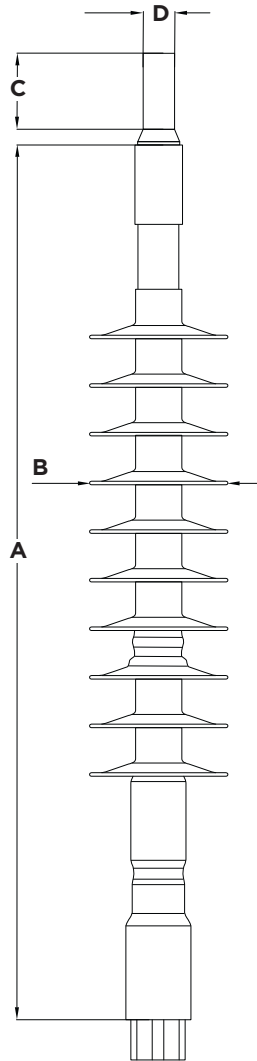
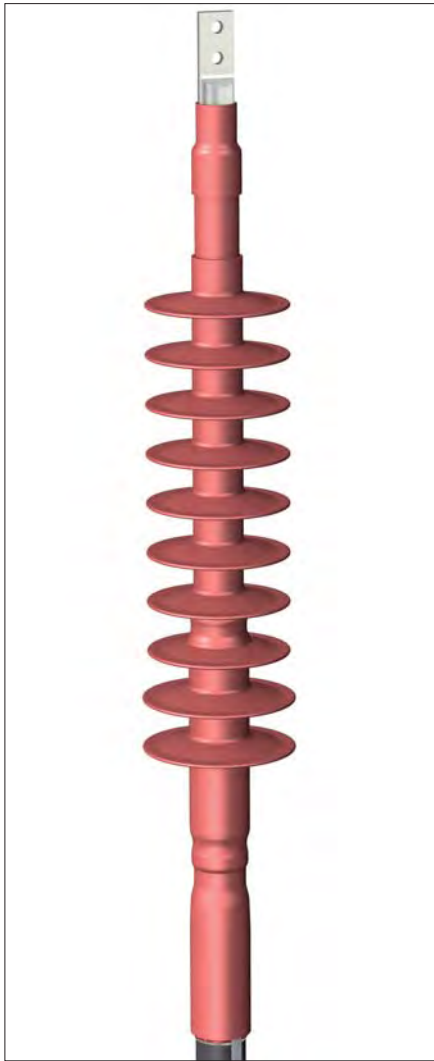

Technical data

Product description	Conductor cross section (mm ²)	Diameter over cable insulation (prepared) (mm)	max. Diameter over outer cable sheath (mm)	min. Creepage Distance (mm)
LHVT-72H	300 - 2500	38 - 55	70	up to 3100
LHVT-72H		48 - 65	80	up to 3100
LHVT-72H		58 - 77	100	up to 3100
LHVT-72H		70 - 86	110	up to 3100

Dimensions

Product description	A (mm)	B (mm)	C (mm)	D* (mm)
LHVT-72H	1560	220	125	30/40/50
LHVT-72H	1560	220	125	30/40/50
LHVT-72H	1560	220	125	30/40/50
LHVT-72H	1560	220	125	30/40/50

* different studs and pads are available on request

Raychem Heat-Shrinkable Terminations OHVT-123H

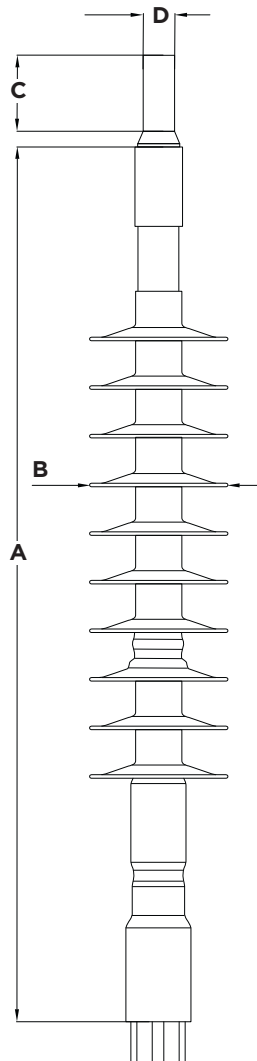
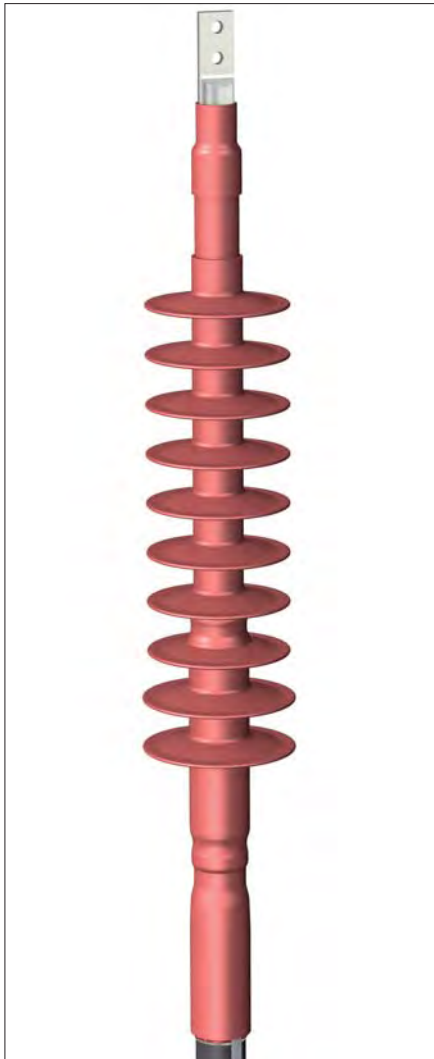

Technical data

Product description	Conductor cross section (mm ²)	Diameter over cable insulation (prepared) (mm)	max. Diameter over outer cable sheath (mm)	min. Creepage Distance (mm)
OHVT-123H	95 - 1600	30 - 45	60	up to 3100
OHVT-123H		38 - 55	70	up to 3100
OHVT-123H		48 - 65	80	up to 3100
OHVT-123H		58 - 77	100	up to 3100
OHVT-123H		70 - 86	110	up to 3100

Dimensions

Product description	A (mm)	B (mm)	C (mm)	D* (mm)
OHVT-123H	1560	220	125	30/40/50
OHVT-123H	1560	220	125	30/40/50
OHVT-123H	1560	220	125	30/40/50
OHVT-123H	1560	220	125	30/40/50
OHVT-123H	1560	220	125	30/40/50

* different studs and pads are available on request

Raychem Heat-Shrinkable Terminations for DC Filter Cables FCEV

Application

The cable is prepared in the same simple and easy way as for Raychem medium voltage terminations without sanding or pencilling. Based on the design of Raychem high voltage terminations, the filter cable termination consists of a staggered layer of stress control tubings and patches. A heat-shrinkable non-tracking insulation tubing and shed are shrunk over the stress control system and ensure a reliable seal to the lug and the oversheath. A mechanical lug covering cross sections from 35mm² to 95mm² is supplied with the kit. The mechanical lug has an M10 thread on the top for easy connection to connecting busbars. The termination is supplied as a single phase termination. A solderless earth connection for cables with metal sheath is included in the termination kit.

Features

- Compact and modular design
- Heat-shrinkable stress control sleeves
- Non-tracking, heat-shrinkable outer insulation
- Easy to install
- No special or expensive tools
- Lightweight components
- Unlimited shelf life under normal storage conditions
- No oil or compound filling
- Reduced waste for disposal

Construction and Design

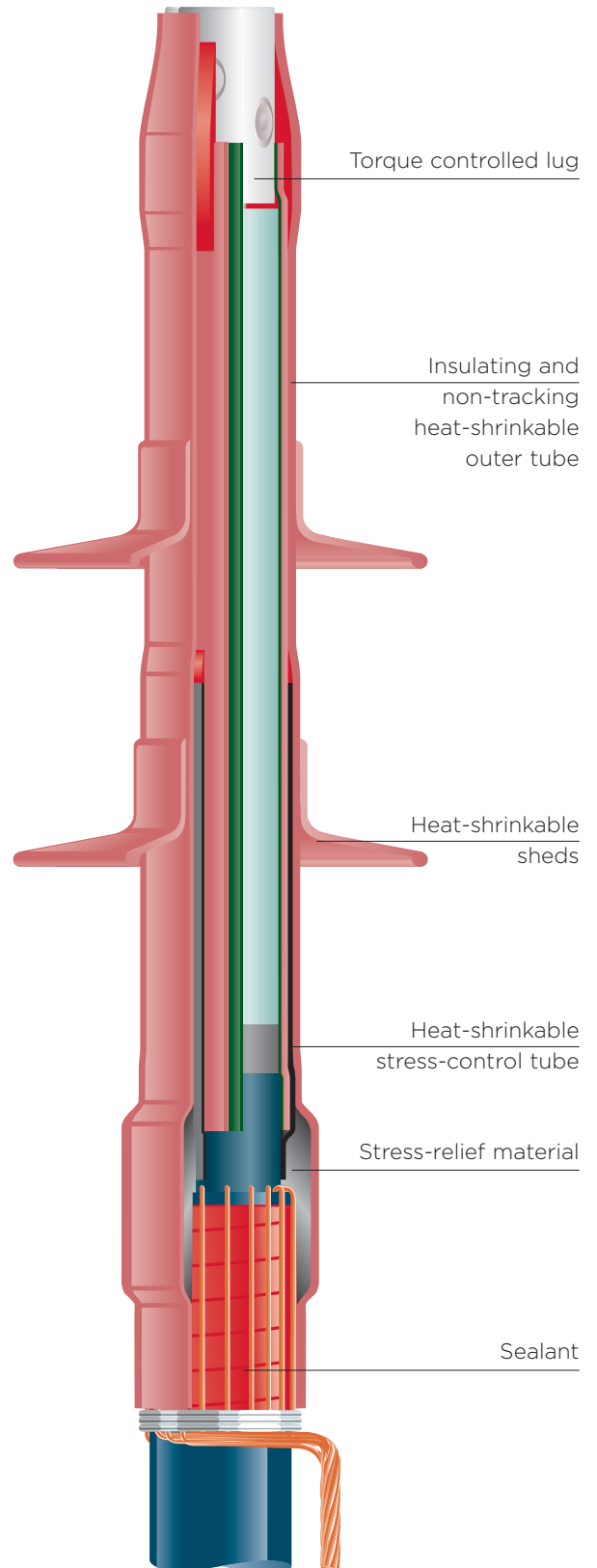

Max. operating voltage U_m (kV)	111	150
DC withstand test (kV)	200	300
Rated lightning impulse withstand voltage (BIL) (kV)	240	325
Partial discharge measurement (pC)	< 5 @ 42kV	< 5 @ 52kV

Raychem Heat-Shrinkable Terminations for DC Filter Cables FCEV

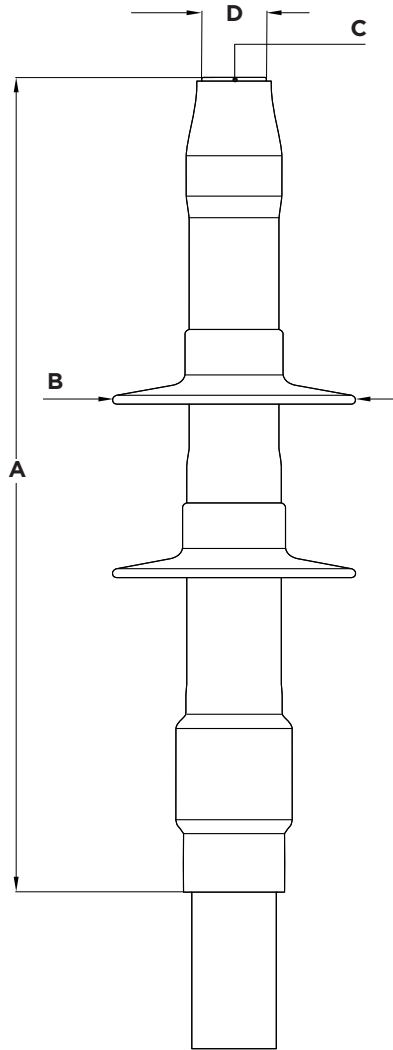
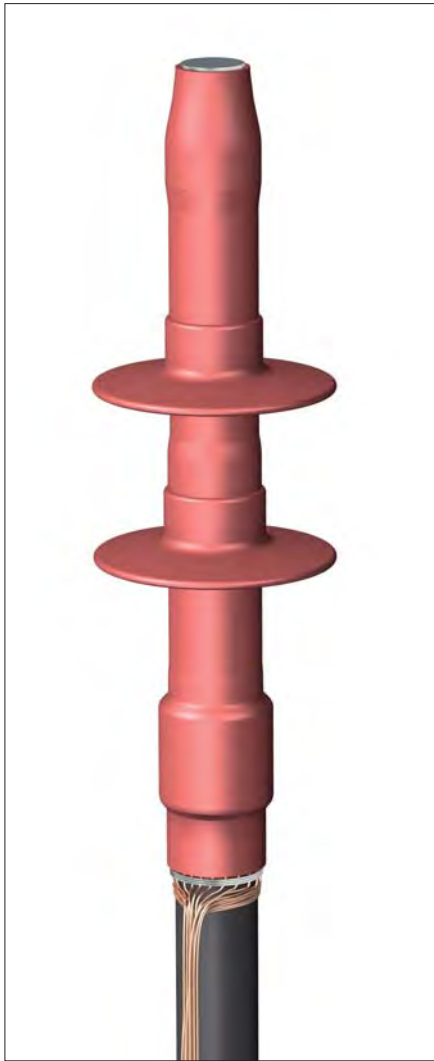

Technical data

Product description	No load voltage U_L (kV)	Conductor cross section (prepared) (mm ²)	Diameter over cable insulation (mm)	min. Creepage Distance (mm)
FCEV-111	111	35 - 95	26 - 38	1200
FCEV-150	150	35 - 95	26 - 38	1200
FCEV-150-1	150	95 - 240	38 - 52	1200

Dimensions

Product description	A (mm)	B (mm)	C	D (mm)
FCEV-111	500	155	M10	32
FCEV-150	700	155	M10	32
FCEV-150-1	700	155	M10	32

Raychem Dry Compact Switchgear & Transformer Terminations PHVS & PHVT

Application

The dry compact switchgear termination for voltage classes up to 145 kV is designed to be installed in cable entry housings of gas-insulated switchgear (GIS). It complies with IEC 62271-209 standard, which essentially specifies the interfaces between the termination and the switchgear. Therefore, the termination will fit into all GIS that comply with IEC 62271-209. Adapters are available to match the dimensions of wet (oil-filled) type terminations, and older designs specified in IEC 60859. The termination operates in SF₆ but also in insulating liquids like transformer oil. A corona shield at the top of the termination then provides the necessary shielding for the terminal. The termination is easily separable and consists of a plug-in part and an epoxy resin insulator. The insulator can be installed by the GIS or transformer manufacturer directly at the factory, saving installation time on-site and reducing the risk of contamination of the cable entry housing. For short cable links, due to the short length and light weight of the plug-in part, it can be also pre-installed by the cable manufacturer, further reducing the time required to install a substation.

Features

- Dry interfaces, no oil-filling
- Dimensions comply with IEC 62271-209
- Pressure-tight resin housing
- Operates in SF₆ and insulating liquids
- Pre-fabricated and factory-tested Si-rubber stress cone
- Torque-controlled or wedge-type multi-contact conductor bolt
- No special tools required to install the termination
- Isolated cable gland for sectionalization
- Type tested according to IEC 60840 and IEC 62271-209 standards

Construction and Design

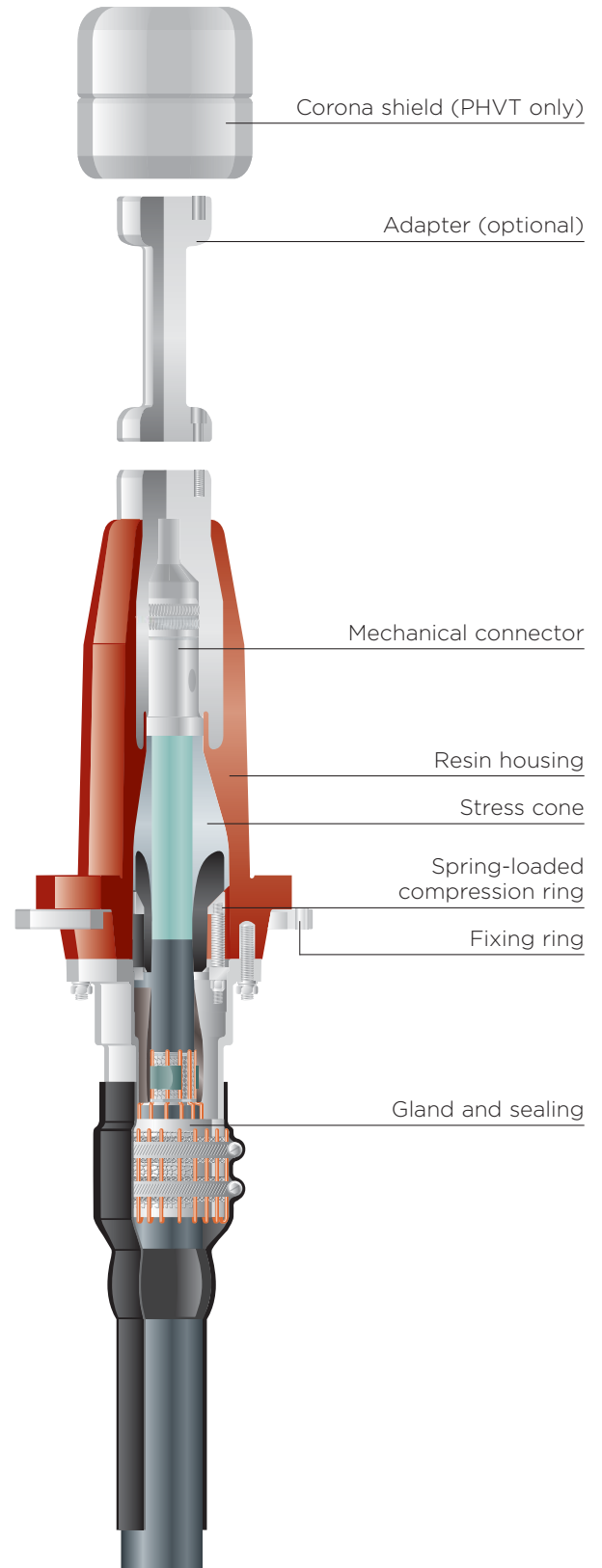

Max. operating voltage U _m (kV)	72.5	123	145
Standards	IEC 60840 IEC 62271-209	IEC 60840 IEC 62271-209	IEC 60840 IEC 62271-209
Rated voltage U (kV)	60 - 69	110 - 115	132 - 138
Rated lightning impulse withstand voltage (BIL) (kV)	325	550	650
Partial discharge measurement (pC)	< 5	< 5	< 5

Raychem Dry Compact Switchgear Terminations PHVS-72

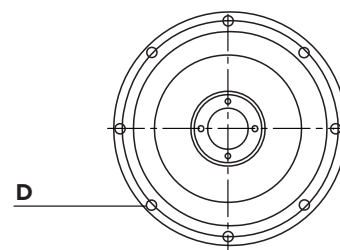
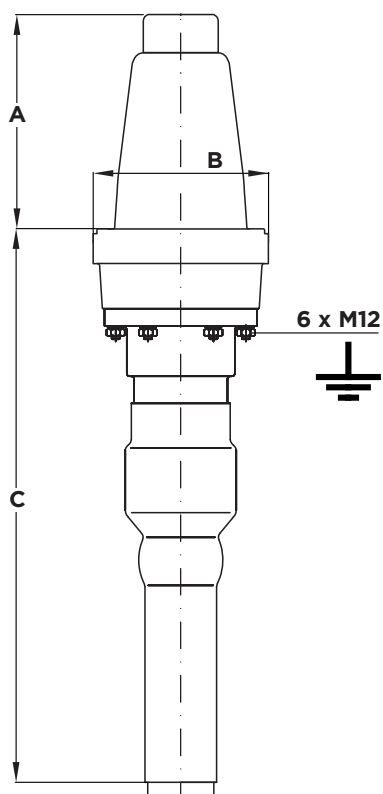

Technical data

Product description	Conductor cross section (mm ²)	Diameter over cable insulation (prepared) (mm)	max. diameter over outer cable sheath (mm)	min. Creepage Distance (mm)
PHVS-72	95 - 1200	34 - 78	120	255

Dimensions

Product description	A (mm)	B (mm)	C (mm)	D (mm)
PHVS-72	310	245	800	8 x 12

Raychem Dry Compact Switchgear Terminations PHVS-145

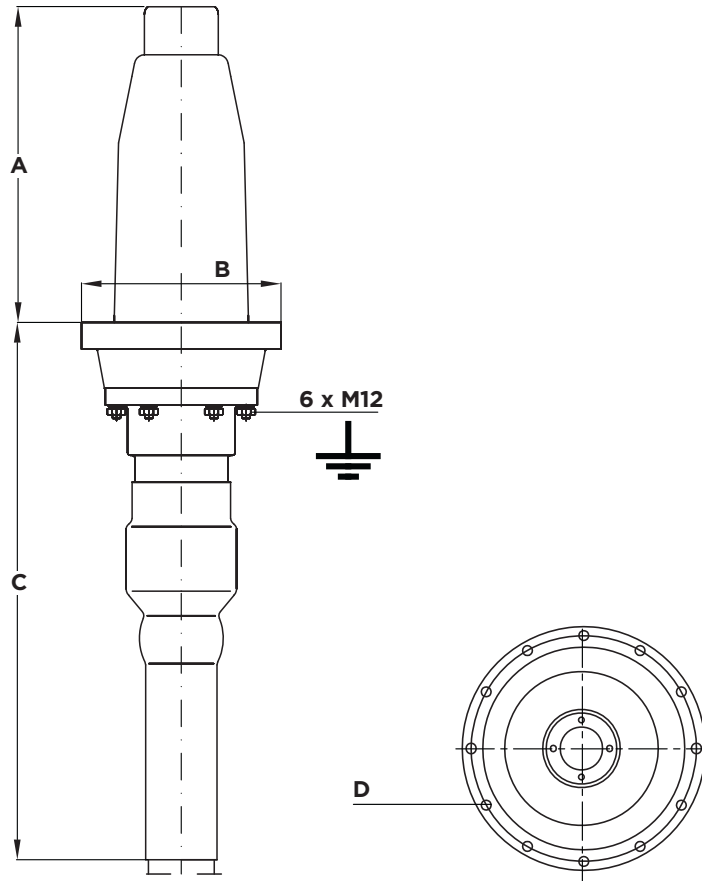

Technical data

Product description	Conductor cross section (mm ²)	Diameter over cable insulation (prepared) (mm)	max. diameter over outer cable sheath (mm)	minimal creepage distance (mm)
PHVS-145	95 - 1200	34 - 78	120	414

Dimensions

Product description	A (mm)	B (mm)	C (mm)	D (mm)
PHVS-145	470	297	800	12 x 13.5

Raychem Dry Compact Transformer Terminations PHVT-72

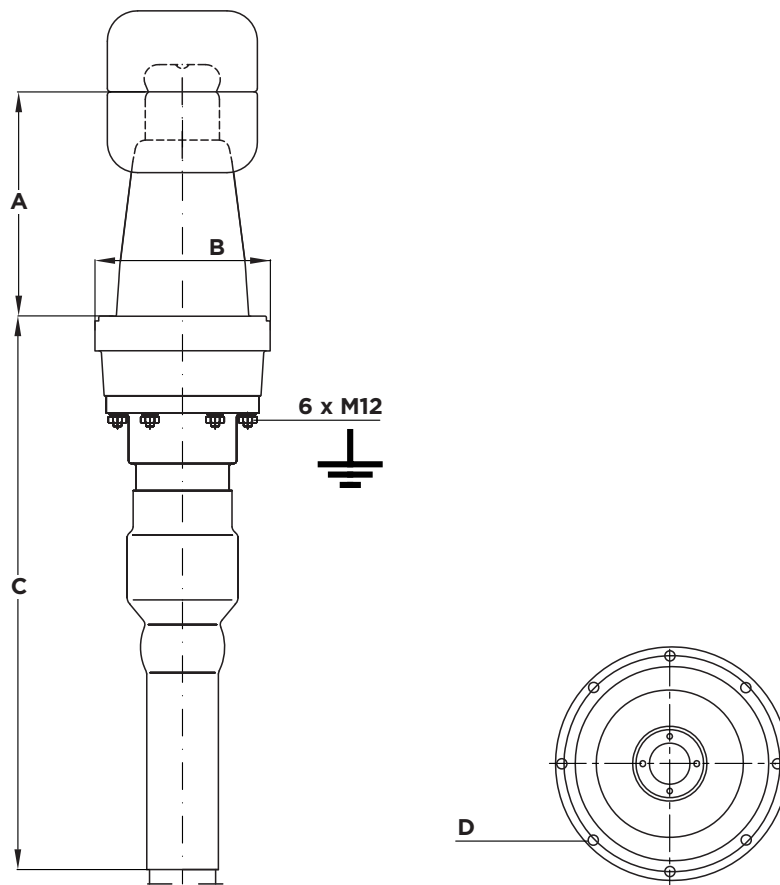

Technical data

Product description	Conductor cross section (mm ²)	Diameter over cable insulation (prepared) (mm)	max. diameter over outer cable sheath (mm)	minimal creepage distance (mm)
PHVT-72	95 - 1200	34 - 78	120	255

Dimensions

Product description	A (mm)	B (mm)	C (mm)	D (mm)
PHVT-72	310	245	800	8 x 12

Raychem Dry Compact Transformer Terminations PHVT-145

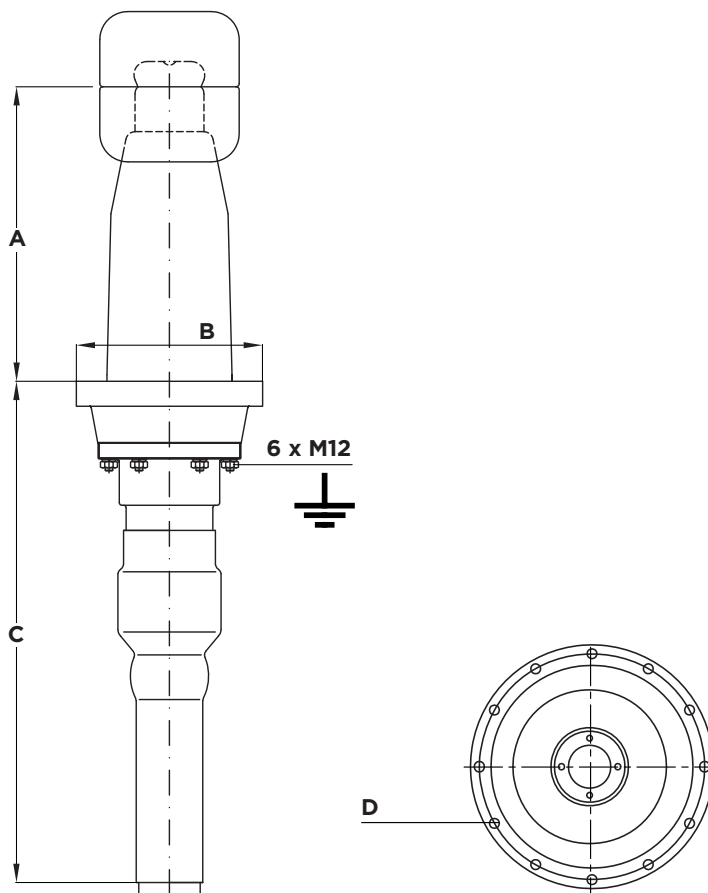

Technical data

Product description	Conductor cross section (mm ²)	Diameter over cable insulation (prepared) (mm)	max. diameter over outer cable sheath (mm)	minimal creepage distance (mm)
PHVT-145	95 - 1200	34 - 78	120	414

Dimensions

Product description	A (mm)	B (mm)	C (mm)	D (mm)
PHVT-145	470	297	800	12 x 13.5

Raychem Switchgear & Transformer Terminations SHVT & THVT

Application

The switchgear termination for voltage classes up to 170 kV is designed to be installed in cable entry housings of gas-insulated switchgear (GIS). It complies with IEC 62271-209 and IEEE 1300 standards, which essentially specify the interfaces between the termination and the switchgear. Therefore, the termination will fit into all GIS that comply with these standards. The termination operates in SF₆ but also in insulating liquids like transformer oil. A corona shield at the top of the transformer termination then provides the necessary shielding for the terminal.

Features

- Si-oil filling
- Dimensions comply with IEC 62271-209 and IEEE 1300
- Pressure-tight resin housing
- Operates in SF₆ and insulating liquids
- Pre-fabricated and factory-tested Si-rubber stress cone
- Torque-controlled conductor bolt
- No special tools required to install the termination
- Isolated cable gland for sectionalization
- Type tested according to IEC 60840, IEC 62271-209 and IEEE 1300 standards

Construction and Design

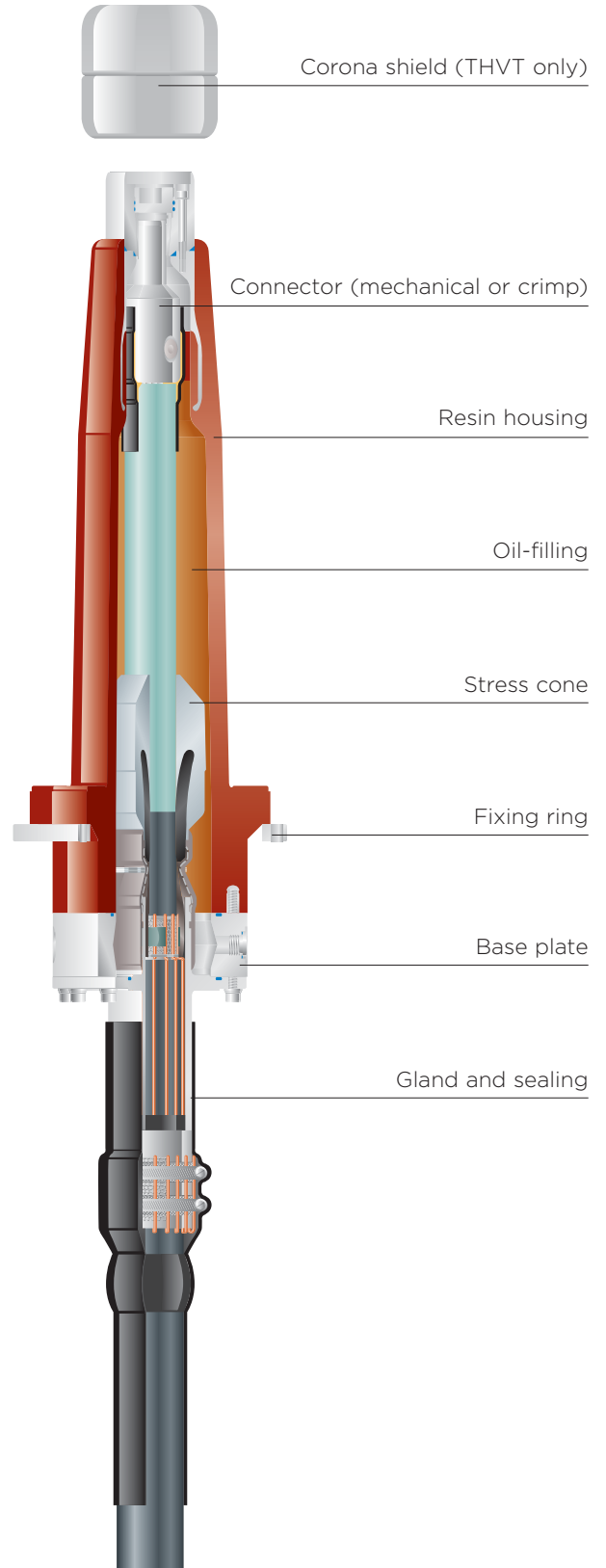

Max. operating voltage U_m (kV)	72.5	123	145
Standards	IEC 60840 IEC 60815	IEC 60840 IEC 60815	IEC 60840 IEC 60815
Rated voltage U (kV)	60 - 69	110 - 115	132 - 138
Rated lightning impulse withstand voltage (BIL) (kV)	325	550	650
Partial discharge measurement (pC)	< 5	< 5	< 5

Raychem Switchgear Terminations SHVT-145

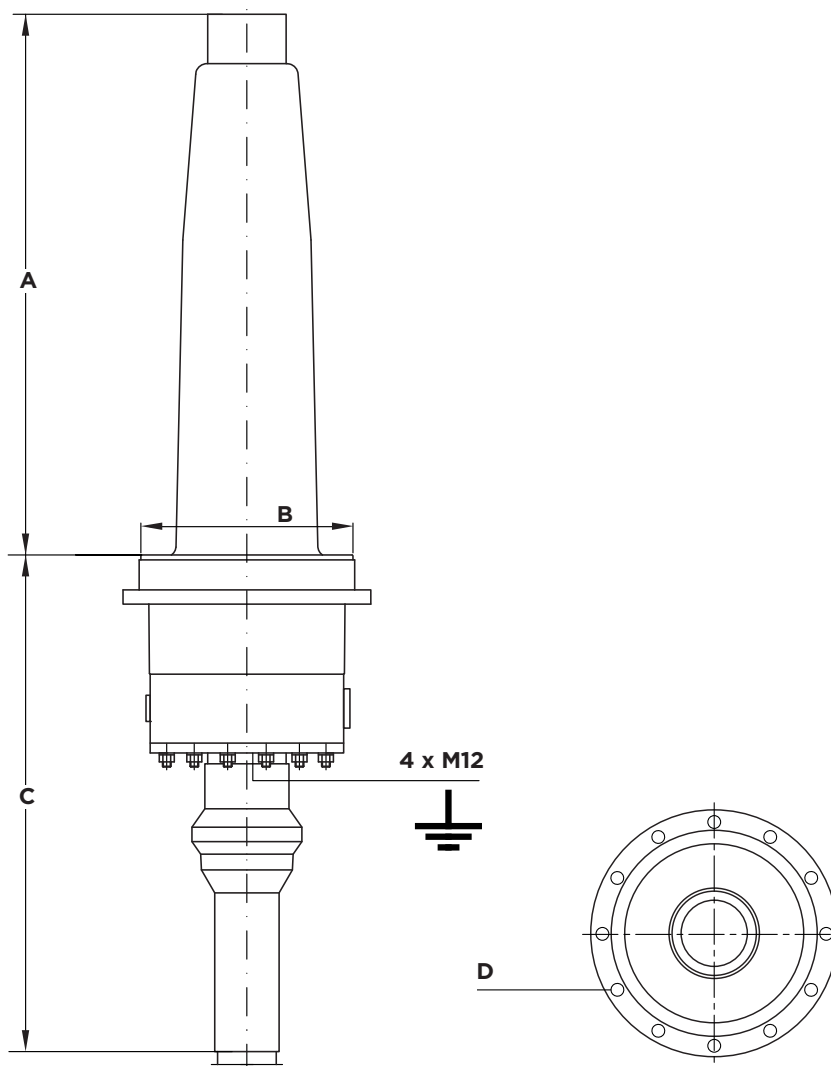

Technical data

Product description	Conductor cross section (mm ²)	Diameter over cable insulation (prepared) (mm)	max. diameter over outer cable sheath (mm)	Oil volume (l)
SHVT-145	95 - 1600	34 - 84	110	8

Dimensions

Product description	A (mm)	B (mm)	C (mm)	D (mm)
SHVT-145	757	298	800	12 x 13.5

Raychem Transformer Terminations THVT-145

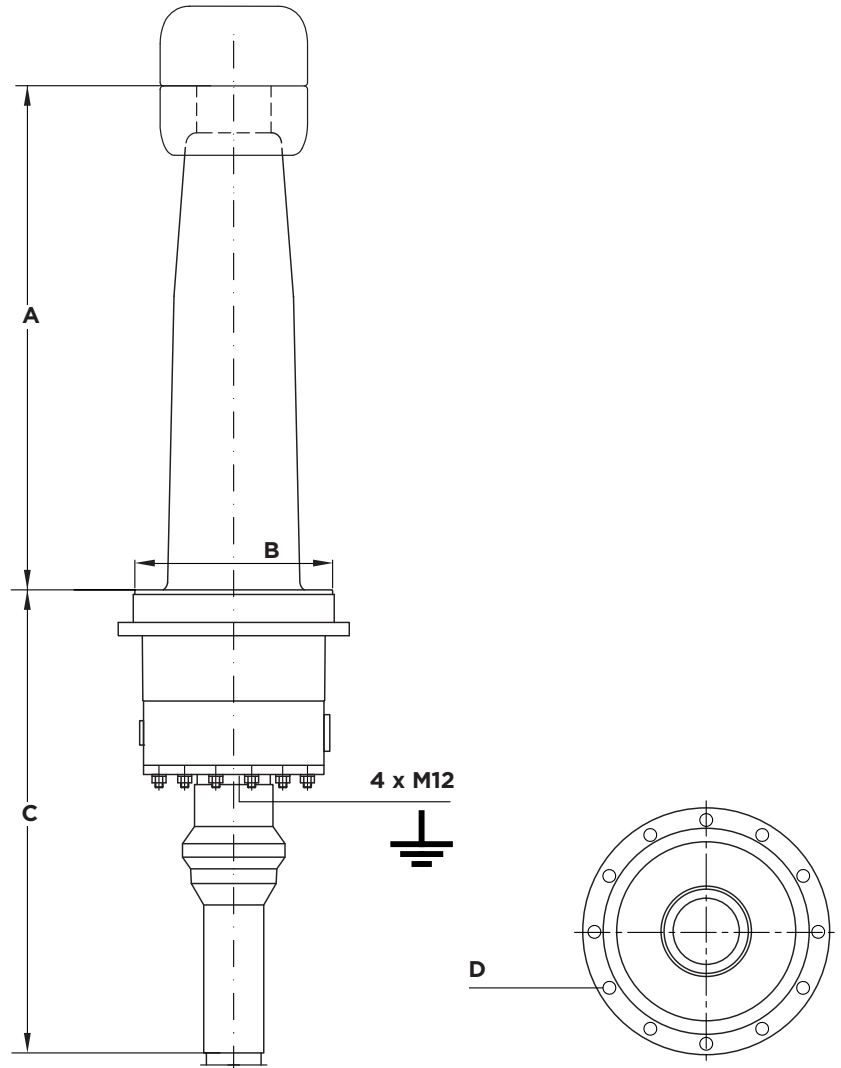

Technical data

Product description	Conductor cross section (mm ²)	Diameter over cable insulation (prepared) (mm)	max. diameter over outer cable sheath (mm)	Oil volume (l)
THVT-145	95 - 1600	34 - 84	110	8

Dimensions

Product description	A (mm)	B (mm)	C (mm)	D (mm)
THVT-145	757	298	800	12 x 13.5

Raychem Heat-Shrinkable Joints for Polymeric Cables 52/72 kV

Application

The joint is based on a heat-shrink design for voltage classes up to 72.5 kV. Polymeric insulated cables of various Designs can be adapted with respect to shielding and metal sheath. Our heat shrink accessories have been used by utilities and industrial companies around the world for more than 35 years. This ongoing field experience has us a leader in materials science and technology for high-voltage applications. Our materials technology is at the core of the development of our heat-shrinkable joints. The materials, used in TE Connectivity Raychem cable accessories, have been extensively optimized with respect to product design and function, manufacturing, and expected service environments.

Features

- Compact and modular design
- Heat-shrinkable stress control sleeves
- Torque-controlled connector
- Joint fits on all polymeric cable construction
- Proven shield continuity concept
- Short cut-back dimension
- Cable size transition possible
- Water and corrosion-resistant
- Easy and fast to install
- No special or expensive tools required
- Lightweight components
- Unlimited storage life-time under normal conditions
- Reduced waste for disposal
- Wide installed base at international customers
- Tested in accordance with IEEE 48 and IEC 60840
- Manufactured according to ISO 9001 and ISO 14001

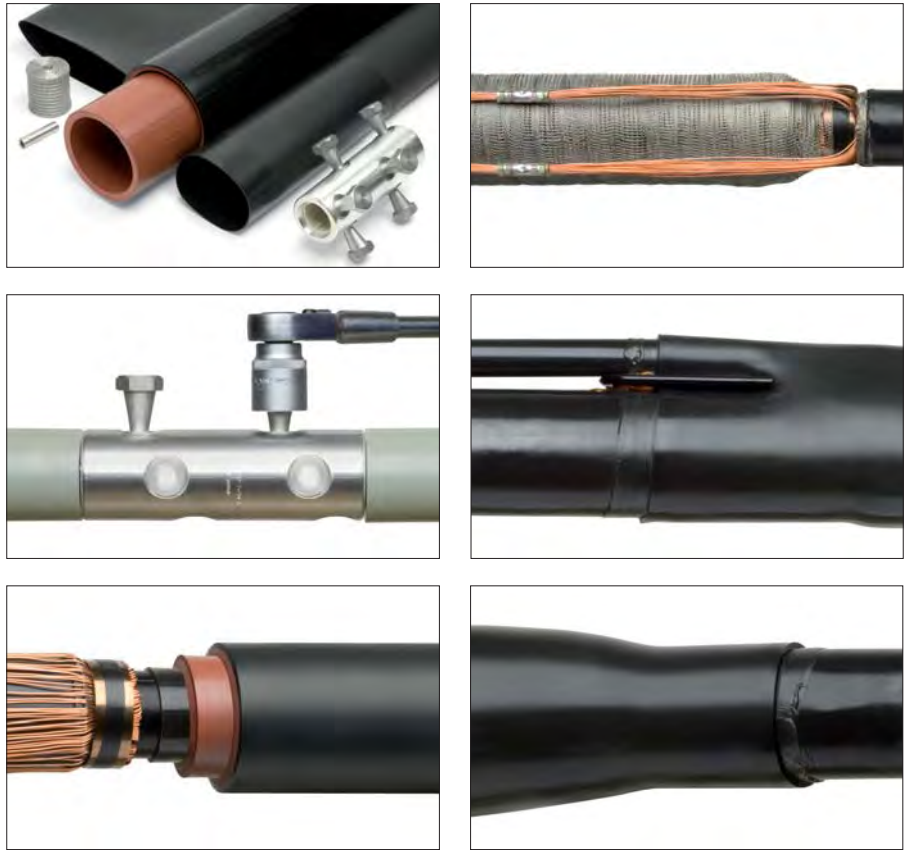

Construction and Design

- 1 Mechanical connector
- 2 Electrical stress control tube
- 3 Insulating tubing
- 4 Screened insulating tubing
- 5 Copper mesh
- 6 Solderless shield connection
- 7 Sealant/mastic
- 8 Outer protection with integrated moisture barrier

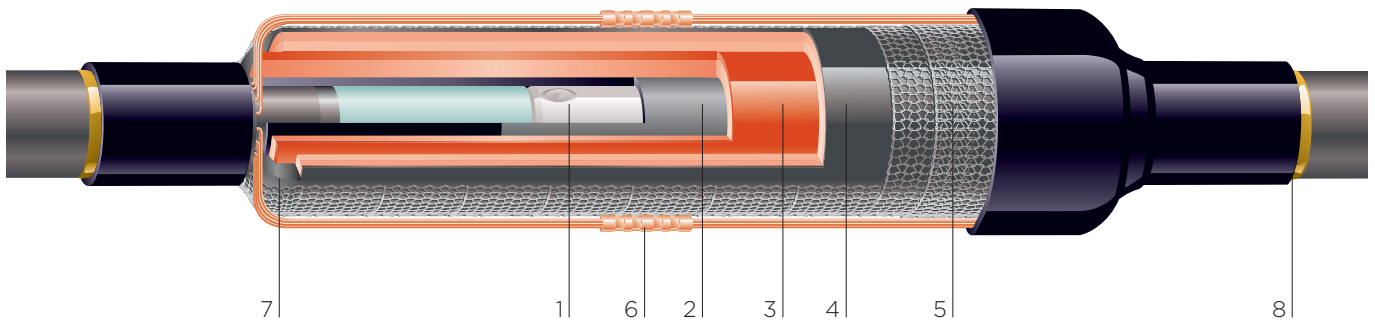

Max. operating voltage U_m (kV)	52	72.5
Standards	IEC 60840	IEC 60840
Rated voltage U (kV)	45 - 47	60 - 69
Rated lightning impulse withstand voltage (BIL) (kV)	250	325
Partial discharge measurement (pC)	< 5	< 5

Raychem Heat-Shrinkable Joints for Polymeric Cables 52 kV



Technical data

Product description	Conductor cross section (mm ²)	Diameter over cable insulation (prepared) (mm ²)	max. diameter over outer cable sheath (mm ²)	Length (mm)	Diameter (mm)	Screen treatment
EHVS-52H	95 - 2500	30 - 45	50	1350	130	Inline / shield break / grounded
EHVS-52H		42 - 55	70	1350	130	Inline / shield break / grounded
EHVS-52H		52 - 65	80	1350	130	Inline / shield break / grounded
EHVS-52H		62 - 77	90	1350	130	Inline / shield break / grounded
EHVS-52H		70 - 86	100	1350	130	Inline / shield break / grounded

Raychem Heat-Shrinkable Joints for Polymeric Cables 72 kV



Technical data

Product description	Conductor cross section (mm ²)	Diameter over cable insulation (prepared) (mm ²)	max. diameter over outer cable sheath (mm ²)	Length (mm)	Diameter (mm)	Screen treatment
EHVS-72H		30 - 45	50	1350	130	Inline / shield break / grounded
EHVS-72H		42 - 55	70	1350	130	Inline / shield break / grounded
EHVS-72H	95 - 2500	52 - 65	80	1350	130	Inline / shield break / grounded
EHVS-72H		62 - 77	90	1350	130	Inline / shield break / grounded
EHVS-72H		70 - 86	100	1350	130	Inline / shield break / grounded

Raychem One Piece Joint up to 145 kV

Application

The joint is a pre-fabricated one-piece design for voltage classes up to 145 kV. Polymeric insulated cables of various designs can be adapted with respect to shielding and metal sheath. The silicone rubber joint body with integrated geometrical stress control, provides proven electrical function. The joint components combine electrical performance, stress control and moisture sealing to provide the important functions required for all high voltage products.

Features

- Premoulded one-piece joint body
- Torque-controlled connector
- Choice of outer sealing and protection systems
- Joint fits on all polymeric cable constructions
- Proven shield continuity concept
- Factory-tested silicon-rubber body
- Special silicone rubber provides perfect compression force for optimised electrical performance
- Simple assembly
- No tension set of joint body
- Moulded thick outer conductive screen
- Geometrical electrical stress control by moulded conductive deflectors
- Type tested according to IEC60840, IEEE404, GB11017 Standards
- Manufactured according to ISO9001 and ISO14001

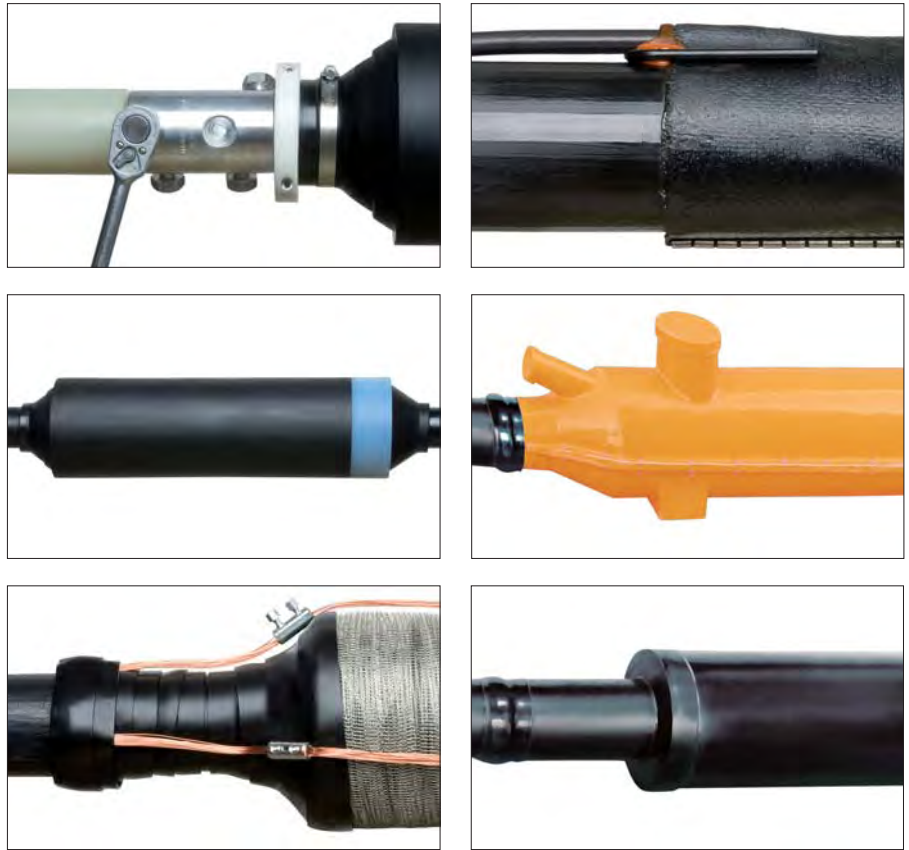

Construction and Design

- 1 Mechanical connector
- 2 Silicone rubber body
- 3 Inner electrode/Faraday cage
- 4 Deflector
- 5 Outer screen
- 6 Copper mesh
- 7 Solderless shield connection
- 8 Sealant/mastic
- 9 Insulating tubes
- 10 Outer protection with integrated moisture barrier

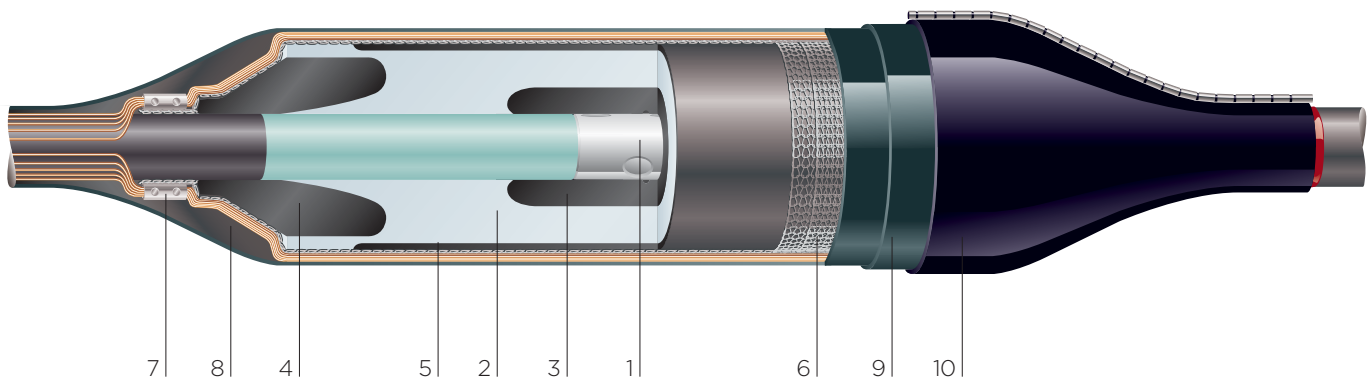

Max. operating voltage U_m (kV)	123	145
Standards	IEC 60840	IEC 60840
Rated voltage U (kV)	110 - 115	132 - 138
Rated lightning impulse withstand voltage (BIL) (kV)	550	650
Partial discharge measurement (pC)	< 5	< 5

Raychem One Piece Joint up to 145 kV



Technical data

Raychem One Piece Joint up to 145 kV - Heat-shrink Outer Protection

Product description	Conductor cross section (mm ²)	Diameter over cable insulation (prepared) (mm ²)	max. diameter over outer cable sheath (mm ²)	Length (mm)	Diameter (mm)	Screen treatment
EHVS-145SW		56 - 64	110	2400	220	Inline / shield break / grounded
EHVS-145SW	500 - 1200	62 - 70	110	2400	220	Inline / shield break / grounded
EHVS-145SW		68 - 78	110	2400	220	Inline / shield break / grounded

Raychem One Piece Joint up to 145 kV - Copper Casing

Product description	Conductor cross section (mm ²)	Diameter over cable insulation (prepared) (mm ²)	max. diameter over outer cable sheath (mm ²)	Length (mm)	Diameter (mm)	Screen treatment
EHVS-145SC		56 - 64	110	2400	270	Inline / shield break
EHVS-145SC	500 - 1200	62 - 70	110	2400	270	Inline / shield break
EHVS-145SC		68 - 78	110	2400	270	Inline / shield break

Raychem One Piece Joint up to 145 kV - Resin & Copper Casing

Product description	Conductor cross section (mm ²)	Diameter over cable insulation (prepared) (mm ²)	max. diameter over outer cable sheath (mm ²)	Length (mm)	Diameter (mm)	Screen treatment
EHVS-145SH		56 - 64	110	2600	320	Inline / shield break
EHVS-145SH	500 - 1200	62 - 70	110	2600	320	Inline / shield break
EHVS-145SH		68 - 78	110	2600	320	Inline / shield break

Raychem Three Piece Joint up to 145 kV

Application

The joint is a pre-fabricated three piece design for voltage classes up to 145 kV. Polymeric insulated cables of various designs can be adapted with respect to shielding and metal sheath. The silicone rubber joint parts with integrated geometrical stress control provides proven electrical function. The joint components combine electrical performance, stress control, and moisture sealing to provide the important functions required for all high voltage products.

Features

- Premoulded three piece joint design
- Torque-controlled connector
- Joint fits on all polymeric cable constructions
- Proven shield continuity concept
- Factory-tested silicone rubber bodies
- Special silicone rubber provides perfect compression force for optimized electrical performance
- Short cut-back dimensions
- No special tools required to install the joint
- Cable size transition possible
- No tension set of joint body
- Moulded outer conductive screen
- Geometrical electrical stress control by moulded conductive deflectors
- Type tested according to IEC60840 and IEEE404 Standards
- Manufactured according to ISO9001 and ISO14001

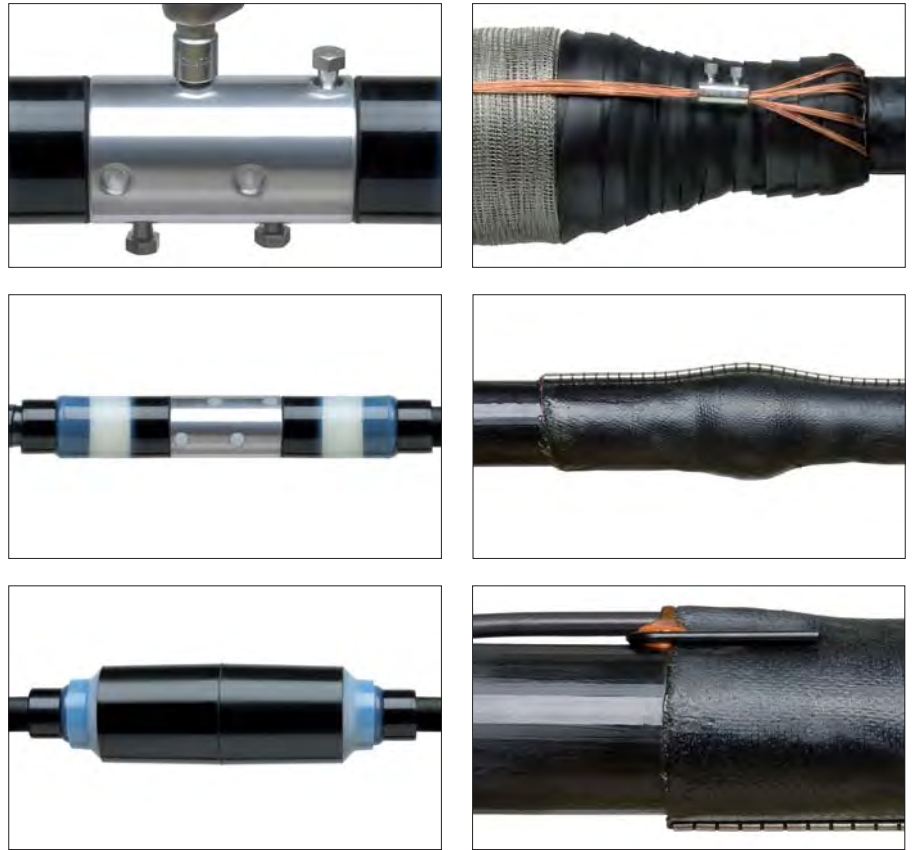

Construction and Design

- 1 Mechanical connector
- 2 Silicone rubber adapter body
- 3 Silicone rubber main body
- 4 Inner electrode/Faraday cage
- 5 Deflector
- 6 Outer screen
- 7 Copper mesh
- 8 Solderless shield connection
- 9 Sealant/mastic
- 10 Insulating tubes
- 11 Outer protection with integrated moisture barrier

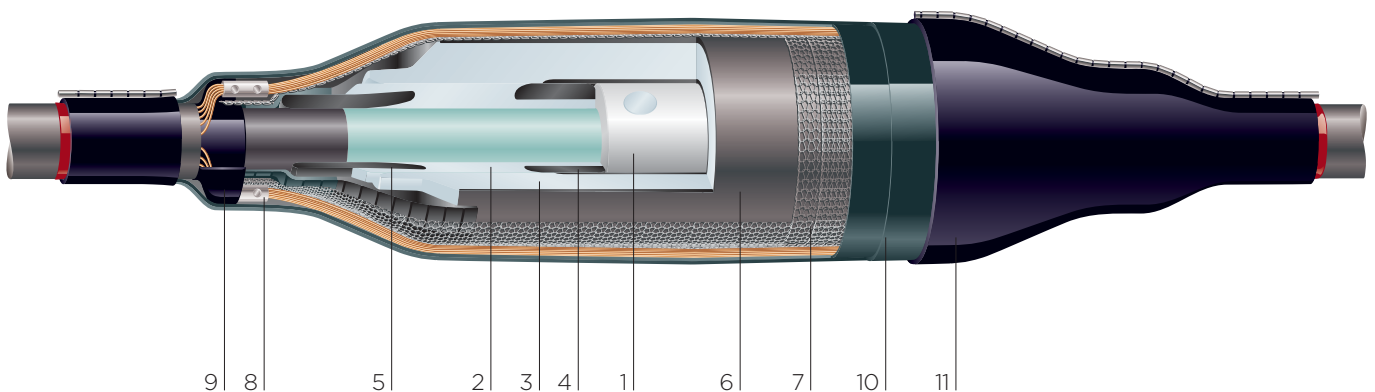

Max. operating voltage U_m (kV)	123	145
Standards	IEC 60840	IEC 60840
Rated voltage U (kV)	110 - 115	132 - 138
Rated lightning impulse withstand voltage (BIL) (kV)	550	650
Partial discharge measurement (pC)	< 5	< 5

Raychem Three Piece Joint up to 145 kV



Technical data

Raychem Three Piece Joint up to 145 kV - Heat-shrink Outer Protection

Product description	Conductor cross section (mm ²)	Diameter over cable insulation (prepared) (mm ²)	max. diameter over outer cable sheath (mm ²)	Length (mm)	Diameter (mm)	Screen treatment
EHVS-145TW		43 - 52	105	1900	200	Inline / shield break / grounded
EHVS-145TW		50 - 58	105	1900	200	Inline / shield break / grounded
EHVS-145TW	185 - 1600	56 - 66	105	1900	200	Inline / shield break / grounded
EHVS-145TW		64 - 74	105	1900	200	Inline / shield break / grounded
EHVS-145TW		72 - 83	105	1900	200	Inline / shield break / grounded

Raychem Three Piece Joint up to 145 kV - Copper Casing

Product description	Conductor cross section (mm ²)	Diameter over cable insulation (prepared) (mm ²)	max. diameter over outer cable sheath (mm ²)	Length (mm)	Diameter (mm)	Screen treatment
EHVS-145TC		43 - 52	105	2400	270	Inline / shield break
EHVS-145TC		50 - 58	105	2400	270	Inline / shield break
EHVS-145TC	185 - 1600	56 - 66	105	2400	270	Inline / shield break
EHVS-145TC		64 - 74	105	2400	270	Inline / shield break
EHVS-145TC		72 - 83	105	2400	270	Inline / shield break

Raychem Three Piece Joint up to 145 kV - Resin & Copper Casing

Product description	Conductor cross section (mm ²)	Diameter over cable insulation (prepared) (mm ²)	max. diameter over outer cable sheath (mm ²)	Length (mm)	Diameter (mm)	Screen treatment
EHVS-145TH		43 - 52	105	2600	320	Inline / shield break
EHVS-145TH		50 - 58	105	2600	320	Inline / shield break
EHVS-145TH	185 - 1600	56 - 66	105	2600	320	Inline / shield break
EHVS-145TH		64 - 74	105	2600	320	Inline / shield break
EHVS-145TH		72 - 83	105	2600	320	Inline / shield break

Add-On Kits for HV Cable Accessories

Arcing Horn for Raychem Outdoor Terminations OHVT

Application

The arcing horns are made to protect the insulators from damage during a flashover. In case of overvoltages, the horns provide a separate breakdown path through the air and keep the flashover from the insulator surface away. As a result of this, the probability of insulator damage by overvoltage is reduced dramatically. The gap length can be adjusted so that the overvoltage withstand-level is variable.

Features

- Easy installation
- Various flashover lengths available
- No contact to the grounding system of the termination and power cable for isolated operation
- May be used for porcelain and composite insulators
- Special designs on request

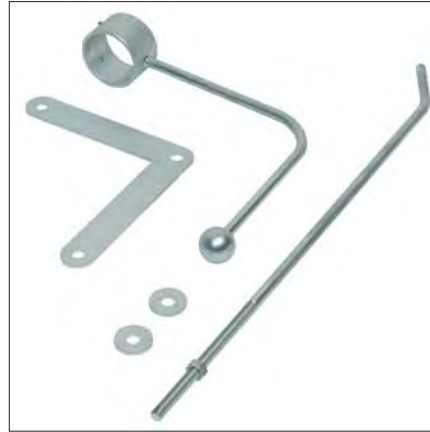

Add-On Kits for HV Cable Accessories

Lifting Device for Raychem Outdoor Terminations OHVT

Application

This lifting device is designed for lifting the installed termination, including the cable, to high positioned installation sites.

Features

- Comfortable and safe installation of the termination on the ground
- Designed to lift the complete installed and oil filled termination with cable
- Easy placement and mounting onto the rack on the pylon
- Applicable for all TE Connectivity terminations up to 170 kV
- Adjustable to all common cable sizes up to a diameter over cable sheath of 110 mm
- Easy assembling and handling
- Entire pulling force is applied to the cable only; no mechanical stress is applied to the termination
- Lifting slings and shackles are not included in the kit, because of their yearly safety check regulations
- Maximum lifting weight 500 kg

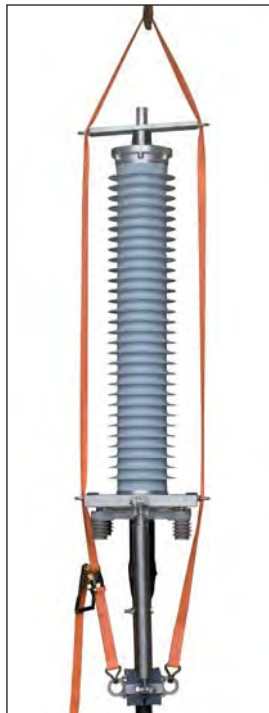

Add-On Kits for HV Cable Accessories Blind Plug for Dry Compact Switchgear and Transformer Terminations

Application

Suitable for use where the switchgear needs to be tested or is under operation without a cable connection. The blind plug (also known as dead end plug or dummy plug) is used to close the socket of the cable entry housing.

Features

- Voltage proof and can be used for continuous operation at nominal voltage
- Every stress control element of the blind plug is routine tested
- Easy installation - similar to standard plug in
- Blind plug is removable and can be used as a temporary solution until the cable is connected
- Blind plug is re-usable
- Externally type tested according to the IEC 60840 standard



Add-On Kits for HV Cable Accessories Accessories Dry Compact Switchgear and Transformer Terminations

Our product portfolio includes not the high-voltage cable accessories but also their add-on accessories. The range shown below doesn't cover all available accessories. Special components can be made on request.

Portfolio:

- Test plates
- Protection caps
- Extenders (dogbones)
- Special connectors



Add-On Kits for HV Cable Accessories

High Voltage Connectors for Outdoor Terminations

Application

Our full line of connectors and accessories for high voltage cable accessories covers most applications in an electrical network. These connectors are typically used for the connection of outdoor terminations to bus bars or overhead lines. Industry-leading Raychem high voltage cable accessories are combined with in-house engineered high-voltage connectors to make assemblies that are easy to install and completely reliable in the energy environment.

Features

- High-strength aluminium alloy
- Various sizes available
- Individual solutions and special designs are available upon request
- High reliability and operates under extreme environmental conditions
- Fast and safe installation
- Excellent electrical and mechanical performance
- Easy installation with socket wrench

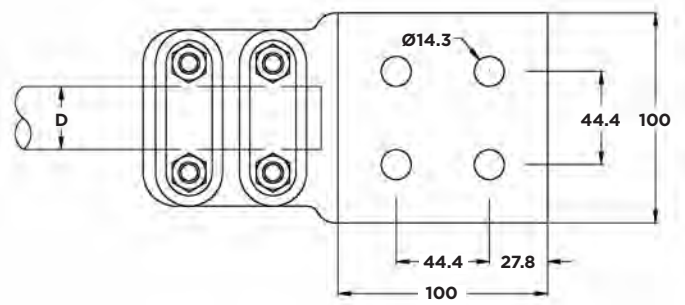
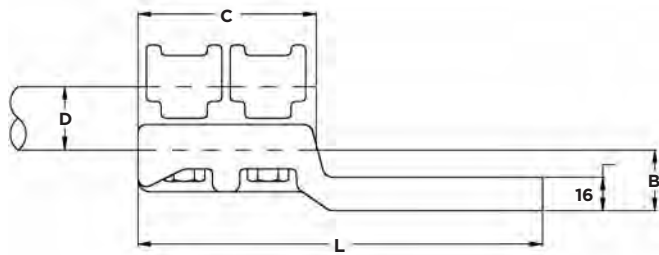

TERMINAL PAD (NEMA)

Description	D	B	C	L	RPN
CD 82 30 100 C290	26 - 31	29	85	193	707021-1
CD 82 40 100 C290	36 - 41	32	92	200	707127-1
CD 82 50 100 C290	46 - 51	25	94	207	718671-1

Dimensions in mm

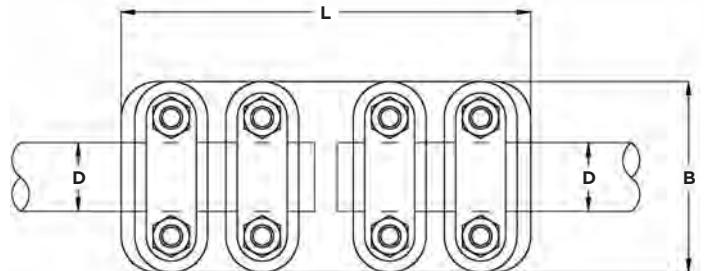
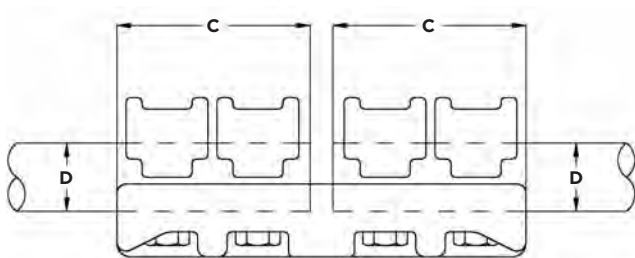

STRAIGHT ROD

Description	D	B	C	L	RPN
RD 82 30	26 - 31	84	85	180	706684-1
RD 82 40	36 - 41	102	92	195	706685-1

Dimensions in mm

Add-On Kits for HV Cable Accessories

High Voltage Connectors for Outdoor Terminations

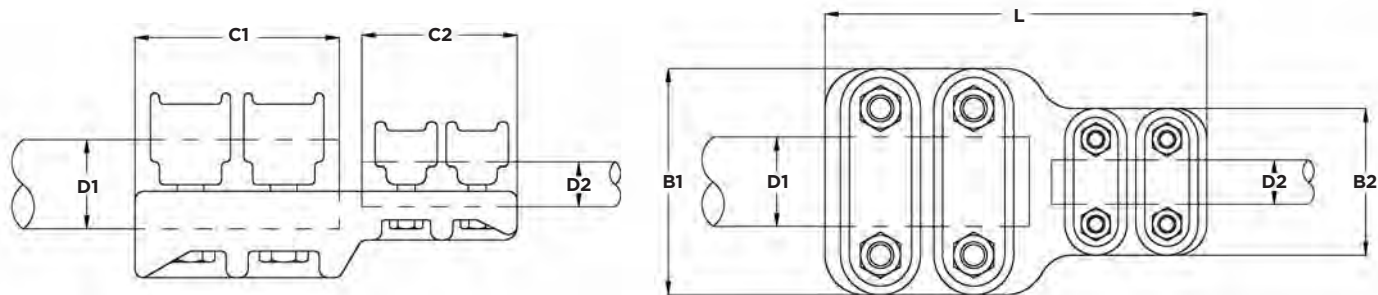

STRAIGHT TRANSITION ROD

Description	D1	D2	B1	B2	C1	C2	L	RPN
RD 82 30 20	26 - 31	16 - 21	84	66	85	70	165	706948-1
RD 82 30 25	26 - 31	21 - 26	84	66	85	70	165	706636-1
RD 82 35 30	26 - 31	31 - 36	84	84	85	85	180	706949-1
RD 82 40 20	36 - 41	16 - 21	102	66	92	70	172	706700-1
RD 82 40 25	36 - 41	21 - 26	102	66	92	70	172	706635-1
RD 82 40 30	36 - 41	26 - 31	102	84	92	85	187	706655-1
RD 82 40 35	36 - 41	31 - 36	102	84	92	85	187	706663-1
RD 82 50 20	46 - 51	16 - 21	112	66	92	70	174	712016-1
RD 82 50 25	46 - 51	21 - 26	112	66	92	70	174	716341-1
RD 82 50 30	46 - 51	26 - 31	112	84	92	85	189	711000-1
RD 82 50 35	46 - 51	31 - 36	112	84	92	85	189	711002-1
RD 82 50 40	46 - 51	36 - 41	112	102	92	92	196	711001-1

Dimensions in mm

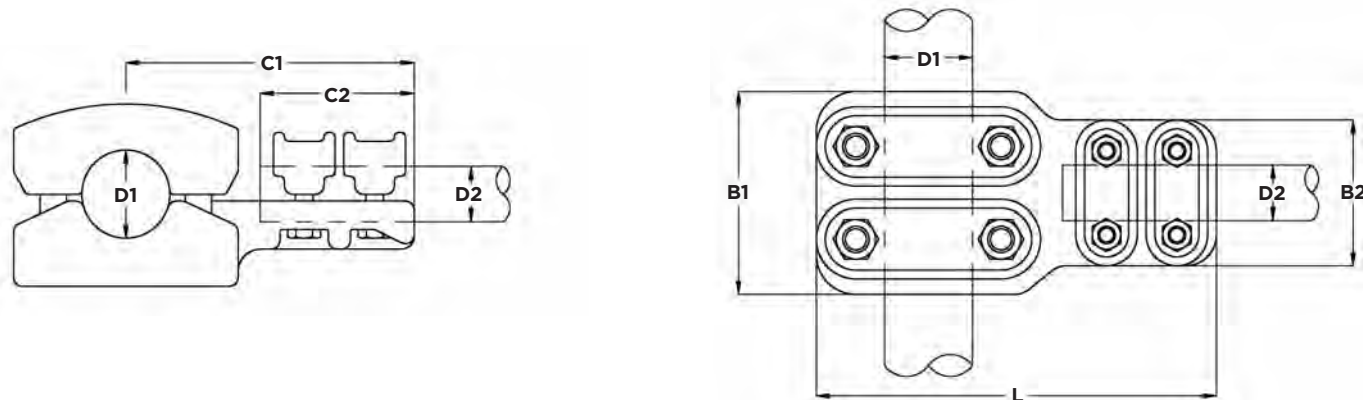

T - ROD

Description	D1	D2	B1	B2	C1	C2	L	RPN
T 82 30 20	26 - 31	16 - 21	84	66	124	70	166	716192-1
T 82 30 25	26 - 31	21 - 26	84	66	124	70	166	706686-1
T 82 30	26 - 31	26 - 31	84	84	140	85	182	706627-1
T 82 30 35	26 - 31	31 - 36	84	84	140	85	182	706683-1
T 82 30 40	26 - 31	36 - 41	84	102	143	92	195	706667-1
T 82 40 20	36 - 41	16 - 21	92	66	131	70	182	716198-1
T 82 40 25	36 - 41	21 - 26	92	66	131	70	182	716106-1
T 82 40 30	36 - 41	26 - 31	92	84	146	85	197	706624-1
T 82 40 35	36 - 41	31 - 36	92	84	146	85	207	706623-1
T 82 40	36 - 41	36 - 41	92	102	151	92	207	706622-1
T 82 50 20	46 - 51	16 - 21	94	66	135	70	191	716203-1
T 82 50 25	46 - 51	21 - 26	94	66	135	70	191	718670-1
T 82 50 30	46 - 51	26 - 31	94	84	151	85	207	716342-1
T 82 50 35	46 - 51	31 - 36	94	84	151	85	207	716204-1
T 82 50 40	46 - 51	36 - 41	94	102	158	92	214	706664-1

Dimensions in mm

Add-On Kits for HV Cable Accessories

High Voltage Connectors for Outdoor Terminations

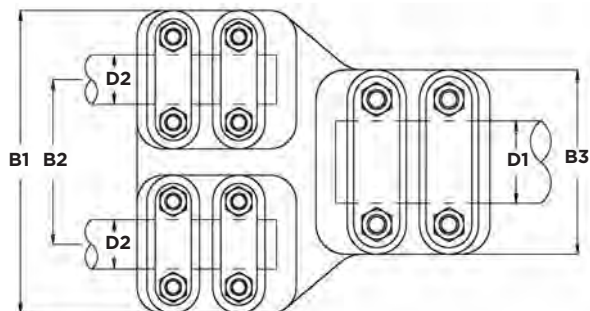
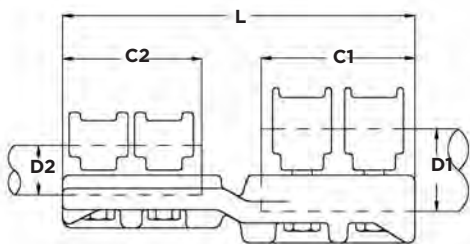

TWIN STRAIGHT ROD

Description	D1	D2	B1	B2	B3	C1	C2	L	RPN
RD 82 F 30 E100 50	46 - 51	36 - 41	184	100	112	94	85	214	789025-1
RD 82 F 35 E100 50	46 - 51	31 - 36	184	100	122	94	85	214	717157-1
RD 82 F 40 E105 50	46 - 51	36 - 41	207	105	112	94	85	230	714766-2

Dimensions in mm

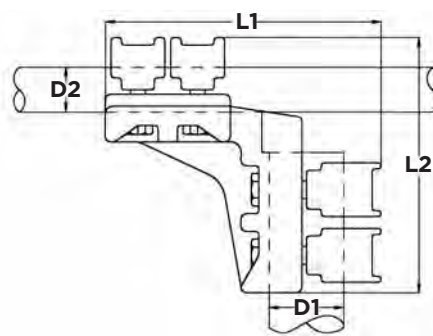
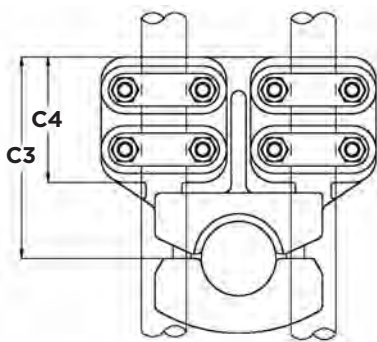
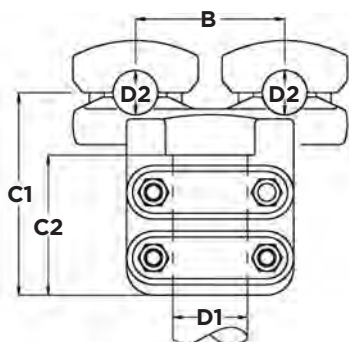

TWIN T ROD

Description	D1	D2	B	C1	C2	C3	C4	L1	L2	RPN
T 82 F 30 E100 50	46 - 51	36 - 41	100	136	94	134	84	185	171	793423-1
T 82 F 35 E100 50	46 - 51	31 - 36	100	136	94	134	84	185	171	793337-1
T 82 F 40 E105 50	46 - 51	36 - 41	105	145	94	145	92	186	195	1306071-1

Dimensions in mm

Add-On Kits for HV Cable Accessories

Cable Clamps

Application

The cable clamps are made out of polyamide material in order to deliver the required mechanical performance.

Features

- Withstand high short-circuit currents
- Constant circumferential surface pressure on the cables
- UV resistant
- Polyamide provides mechanical, heat, and chemical resistance

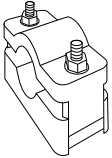
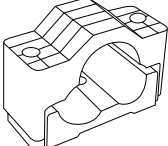

Type	Cable Ø (mm)	Description	Dimensions (mm)			a	Screw Size
			L	B	H		
 HVCA-CABCLAMP-ST	18 - 26	HVCA-CABCLAMP-ST18-26	77	45	36 - 44	70	M10x85
	26 - 38	HVCA-CABCLAMP-ST26-38	92	60	48 - 60	90	M12x110
	36 - 52	HVCA-CABCLAMP-ST36-52	107	60	58 - 74	110	M12x125
	50 - 75	HVCA-CABCLAMP-ST50-75	128	60	76 - 101	130	M12x150
	75 - 100	HVCA-CABCLAMP-ST75-100	169	80	110 - 135	155	M14x190
	100 - 130	HVCA-CABCLAMP-ST100-130	200	80	141 - 170	175	M14x210
 HVCA-CABCLAMP-TRI	3x 25 - 40	HVCA-CABCLAMP-TRI25-40	172	80	80 - 108	70	M14x160
	3x 38 - 53	HVCA-CABCLAMP-TRI38-53	190	80	85 - 115	90	M14x170
	3x 53 - 66	HVCA-CABCLAMP-TRI53-66	215	80	137 - 168	110	M14x210
	3x 67 - 82	HVCA-CABCLAMP-TRI67-82	252	100	140 - 175	130	M16x245
	3x 82 - 98	HVCA-CABCLAMP-TRI82-98	284	100	168 - 205	155	M16x255
	3x 99 - 120	HVCA-CABCLAMP-TRI99-120	342	115	144 - 203	175	M16x247

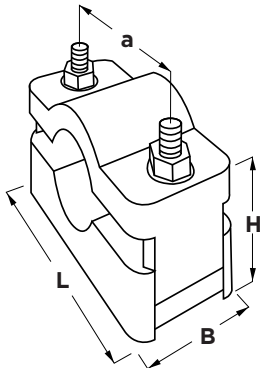

HVCA-CABCLAMP-ST

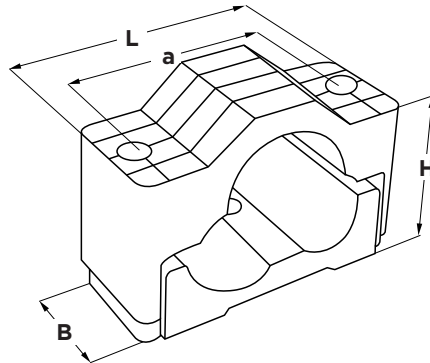

HVCA-CABCLAMP-TRI

Add-On Kits for HV Cable Accessories

Raychem Fibre-Optic Add-On Kit for HV Cable Accessories

Application

The Raychem fibre-optic add-on kit is designed to connect the glass fibres integrated in HV cables. The kit includes all components required to seal the cable jacket and the fibre-optic outlet securely and to protect the sensitive optical fibres that are housed inside the steel pipes.

The standard add-on kit is suitable for connecting two individual steel pipes each with a maximum of 24 optical fibres.

Features

- The splice box is suitable for cross-bonding and straight-through joints
- Gel-sealing technology ensures reliable operation even when buried joints are used
- Enhanced fibre management
- The splice box is easy to open and close without the use of special tools
- The kits are available for Raychem joints and terminations (outdoor and equipment terminations)



Raychem Link Boxes

Application

Single-core cables in operation carry alternating currents and induced voltages in the metallic sheath of the cable. Depending on the sheath bonding, these currents may lead to circulating currents flowing in the cable sheath, which reduces the transmission capacity of the cable and causes additional heating. Link boxes are used for earthing and bonding cable sheaths of single-core cables so that the induced voltages and circulating currents are eliminated or reduced.



Advanced Features

- Various designs available
- Stainless steel box
- Various mechanical protection levels up to IP68
- Electrically and mechanically type tested
- 1-phase and 3-phase boxes
- With or without surge arresters
- With or without removable links
- For concentric cables or single-core cables
- Cross sections up to 300 mm²
- ZnO sheath voltage limiter for up to 7kV protection levels, larger protection levels upon request
- Short circuit current up to 40 kA 1 sec



Construction and Design

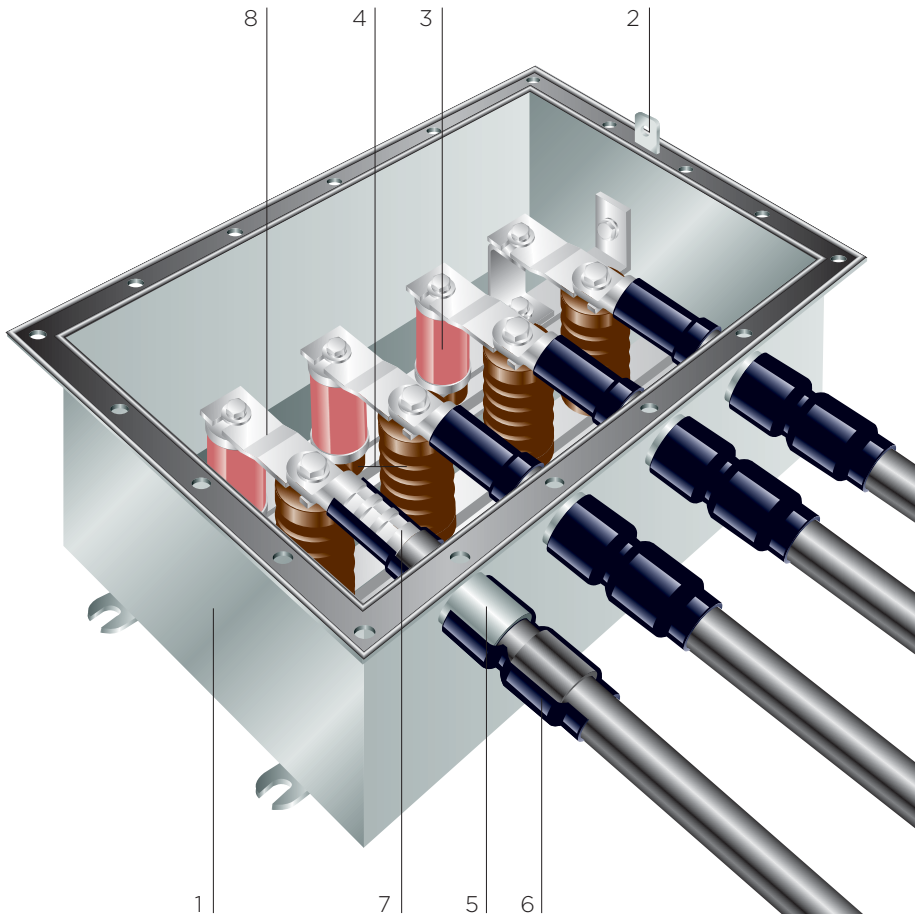

- 1 Stainless steel housing
- 2 Lockable lid
- 3 Sheath voltage limiters (optional)
- 4 Epoxy resin post-insulators (
- 5 Cable entries
- 6 Outer sealing
- 7 Compression lugs
- 8 Tinned copper links

Most Popular Cable Sheath Grounding Options:

Single point earthing

On relatively short cable sections, the cable sheaths are solidly bonded together and earthed at one position. The sheaths of the three cable sections are connected and grounded at one point only. At all other points, there is a voltage between sheath and ground that is at its maximum at the farthest point from the ground bond. Since there is no closed sheath circuit, current does not flow along the sheaths and no sheath circulation current loss occurs.

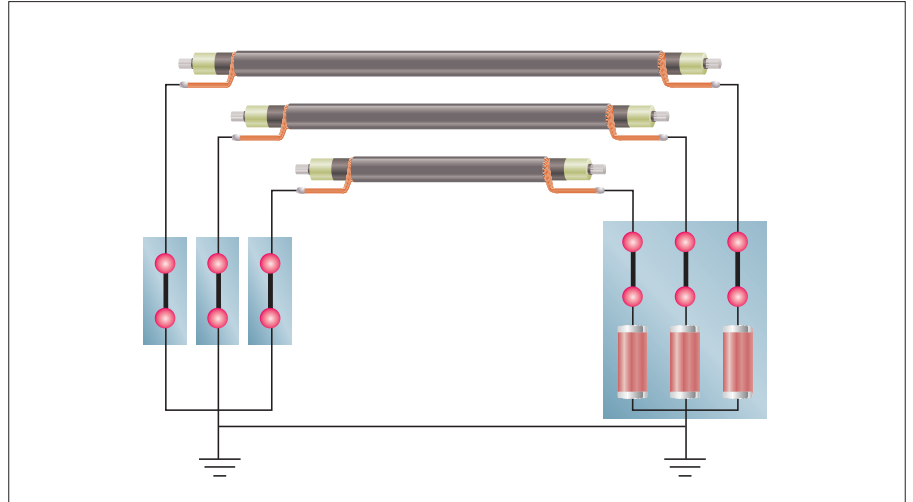

Cross bonding

The cable route is sectionalized into equal lengths. The sections are cross-connected to neutralize the induced voltages. The phase sum of the introduced voltages is zero and, therefore, there is no circulating currents when the cable laying is symmetrical.

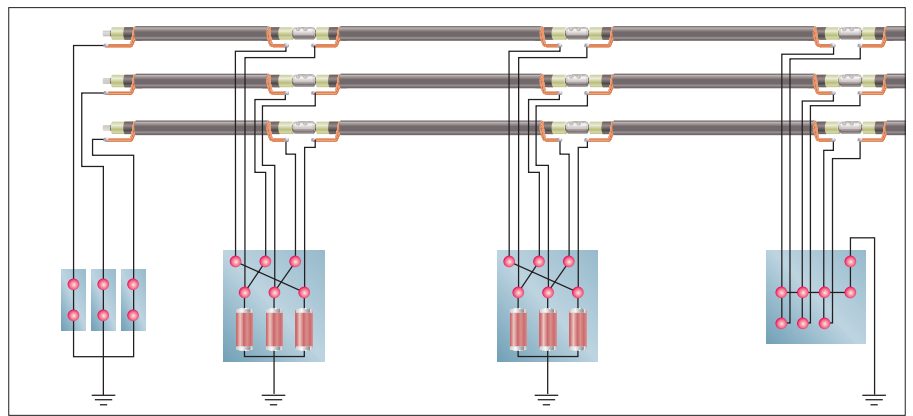

Cross bonding and transposition

For cable laying in unsymmetrical formations, the induced voltages are not equal at each phase and, therefore, the phase sum of the voltages is not zero despite cross-bonding. The cables are transposed at each joint position and the cable sheaths are cross-connected, with each cable occupying the same relative position in the cable formation. By this means, the phase sum of the induced voltage sheaths is the same over three sections.

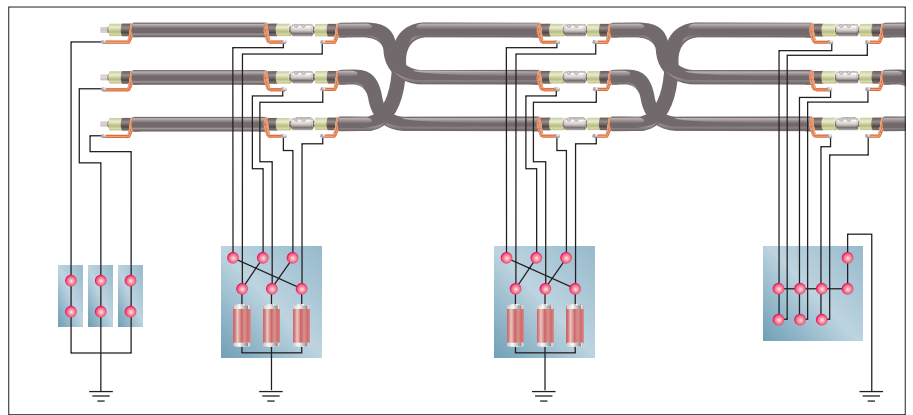

Typical application example:

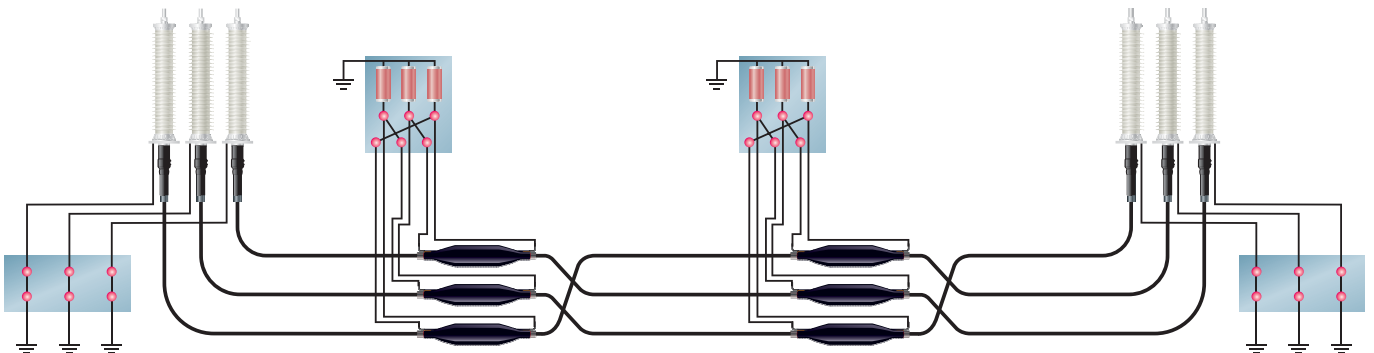

Selection tables for Raychem Link Boxes for single core cables

Link Diagram

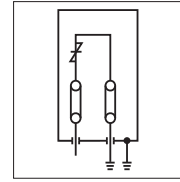
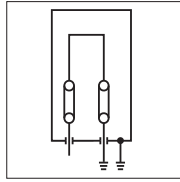

Bonding lead (type)	Single-core	Single-core
Bonding lead (mm ²)	70 - 300	70 - 300
Protection class	IP 68	IP 68
Application	Buried	Buried
Sheath voltage limiters	N/A	1 kV-6 kV
Box size (LxHxW) (mm)	496x322x451	496x322x451
Material	stainless steel	stainless steel
Total weight	Approx. 35 kg	Approx. 35 kg
Connection links	Removable tinned copper 300 mm ²	Removable tinned copper 300 mm ²
Cable connection	Compression lug	Compression lug
Impulse withstand voltage (kV)	55	55
AC withstand voltage (kV)	25	25
DC withstand voltage (kV)	25	25
Short circuit current (kA/1s)	40	40
Description	HVLB-E-S-0-1-2-U-IP68	HVLB-E-S-x*-1-2-U-IP68

Link Diagram

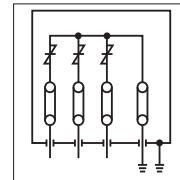
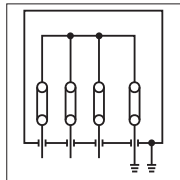

Bonding lead (type)	Single-core	Single-core
Bonding lead (mm ²)	70 - 300	70 - 300
Protection class	IP 68	IP 68
Application	Buried	Buried
Sheath voltage limiters	N/A	1 kV-6 kV
Box size (LxHxW) (mm)	496x322x725	496x322x725
Material	stainless steel	stainless steel
Total weight	Approx. 65 kg	Approx. 65 kg
Connection links	Removable tinned copper 300 mm ²	Removable tinned copper 300 mm ²
Cable connection	Compression lug	Compression lug
Impulse withstand voltage (kV)	55	55
AC withstand voltage (kV)	25	25
DC withstand voltage (kV)	25	25
Short circuit current (kA/1s)	40	40
Description	HVLB-E-S-0-3-2-U-IP68	HVLB-E-S-x*-3-2-U-IP68

Link Diagram

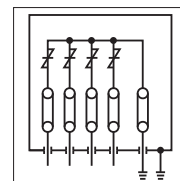
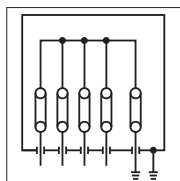

Bonding lead (type)	Single-core	Single-core
Bonding lead (mm ²)	70 - 300	70 - 300
Protection class	IP 68	IP 68
Application	Buried	Buried
Sheath voltage limiters	N/A	1 kV-6 kV
Box size (LxHxW) (mm)	496x322x862	496x322x862
Material	stainless steel	stainless steel
Total weight	Approx. 75 kg	Approx. 75 kg
Connection links	Removable tinned copper 300 mm ²	Removable tinned copper 300 mm ²
Cable connection	Compression lug	Compression lug
Impulse withstand voltage (kV)	55	55
AC withstand voltage (kV)	25	25
DC withstand voltage (kV)	25	25
Short circuit current (kA/1s)	40	40
Description	HVLB-E-S-0-4-2-U-IP68	HVLB-E-S-x*-4-2-U-IP68

* indicates voltage class of sheath voltage limiter (SVL)

Selection tables for Raychem Link Boxes for single core cables

Link Diagram

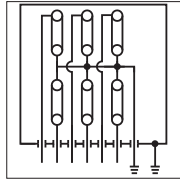

Bonding lead (type)	Single-core
Bonding lead (mm ²)	70 - 300
Protection class	IP 68
Application	Buried
Sheath voltage limiters	N/A
Box size (LxHxW) (mm)	496x322x995
Material	stainless steel
Total weight	Approx. 85 kg
Connection links	Removable tinned copper 300 mm ²
Cable connection	Compression lug
Impulse withstand voltage (kV)	55
AC withstand voltage (kV)	25
DC withstand voltage (kV)	25
Short circuit current (kA/1s)	40
Description	HVLB-E-S-0-6-2-U-IP68

Link Diagram

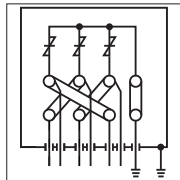

Bonding lead (type)	Single-core
Bonding lead (mm ²)	70 - 300
Protection class	IP 68
Application	Buried
Sheath voltage limiters	1 kV-6 kV
Box size (LxHxW) (mm)	665x395x665
Material	stainless steel
Total weight	Approx. 68 kg
Connection links	Removable tinned copper 300 mm ²
Cable connection	Clamping ring
Impulse withstand voltage (kV)	55
AC withstand voltage (kV)	25
DC withstand voltage (kV)	25
Short circuit current (kA/1s)	40
Description	HVLB-C-S-x*-6-2-U-IP68

Link Diagram

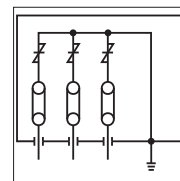
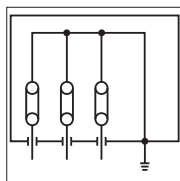

Bonding lead (type)	Single-core	Single-core
Bonding lead (mm ²)	95 - 300	95 - 300
Protection class	IP 56	IP 56
Application	Non buried	Non buried
Sheath voltage limiters	N/A	1 kV-6 kV
Box size (LxHxW) (mm)	310x255x310	310x255x310
Material	stainless steel	stainless steel
Total weight	Approx. 16 kg	Approx. 16 kg
Connection links	Removable copper 240 mm ²	Removable copper 240 mm ²
Cable connection	Compression lug	Compression lug
Impulse withstand voltage (kV)	35	35
AC withstand voltage (kV)	24	24
DC withstand voltage (kV)	40	40
Short circuit current (kA/1s)	-	-
Description	HVLB-GND-0-3	HVLB-GND-x*-3

* indicates voltage class of the sheath voltage limiter (SVL)

Selection tables for Raychem Link Boxes for single core cables

Link Diagram

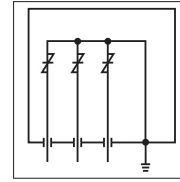
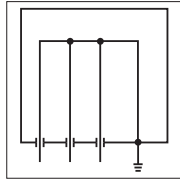

Bonding lead (type)	Single-core	Single-core
Bonding lead (mm ²)	95 - 300	95 - 300
Protection class	IP 56 or IP 68	IP 56 or IP 68
Application	Non buried	Non buried
Sheath voltage limiters	N/A	1 kV-6 kV
Box size (LxHxW) (mm)	310x255x310	310x255x310
Material	stainless steel	stainless steel
Total weight	Approx. 16 kg	Approx. 16 kg
Connection links	Copper 120 mm ²	Copper 120 mm ²
Cable connection	Compression lug	Compression lug
Impulse withstand voltage (kV)	35	35
AC withstand voltage (kV)	24	24
DC withstand voltage (kV)	40	40
Short circuit current (kA/1s)	-	-
Description	EPPA-055-0-3	EPPA-055-x*-3

Link Diagram

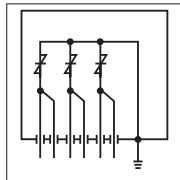

Bonding lead (type)	Single-core
Bonding lead (mm ²)	95 - 300
Protection class	IP 56 or IP 68
Application	Non buried
Sheath voltage limiters	1 kV-6 kV
Box size (LxHxW) (mm)	310x255x310
Material	stainless steel
Total weight	Approx. 16 kg
Connection links	Copper 120 mm ²
Cable connection	Compression lug
Impulse withstand voltage (kV)	35
AC withstand voltage (kV)	24
DC withstand voltage (kV)	40
Short circuit current (kA/1s)	-
Description	EPPA-055-x*-3

Link Diagram

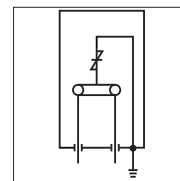
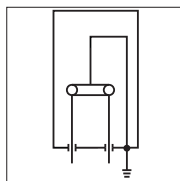

Bonding lead (type)	Single-core	Single-core
Bonding lead (mm ²)	95 - 300	95 - 300
Protection class	IP 56	IP 56
Application	Non buried	Non buried
Sheath voltage limiters	N/A	1 kV-6 kV
Box size (LxHxW) (mm)	300x165x190	300x165x190
Material	stainless steel	stainless steel
Total weight	Approx. 10 kg	Approx. 11 kg
Connection links	Removable copper 120 mm ²	Removable copper 120 mm ²
Cable connection	Compression lug	Compression lug
Impulse withstand voltage (kV)	35	35
AC withstand voltage (kV)	24	24
DC withstand voltage (kV)	40	40
Short circuit current (kA/1s)	-	-
Description	EPPA-055-0-1	EPPA-055-x*-1

* indicates voltage class of the sheath voltage limiter (SVL)

Selection tables for Raychem Link Boxes for concentric (coax) cables

Link Diagram

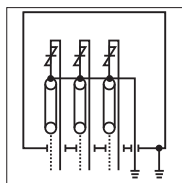

Bonding lead (type)	Concentric (coaxial)
Bonding lead (mm ²)	70 - 300
Protection class	IP 68
Application	Buried
Sheath voltage limiters	1 kV-6 kV
Box size (LxHxW) (mm)	665x395x665
Material	stainless steel
Total weight	Approx. 68 kg
Connection links	Removable tinned copper 300 mm ²
Cable connection	Clamping ring
Impulse withstand voltage (kV)	55
AC withstand voltage (kV)	25
DC withstand voltage (kV)	25
Short circuit current (kA/1s)	40
Description	HVLB-E-C-x*-3-2-U-IP68

Link Diagram

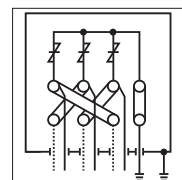
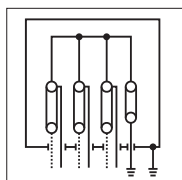

Bonding lead (type)	Concentric (coaxial)	Concentric (coaxial)
Bonding lead (mm ²)	70 - 300	70 - 300
Protection class	IP 68	IP 68
Application	Buried	Buried
Sheath voltage limiters	N/A	1 kV-10 kV
Box size (LxHxW) (mm)	621x356x883	621x356x883
Material	stainless steel	stainless steel
Total weight	Approx. 100 kg	Approx. 100 kg
Connection links	Removable tinned copper 300 mm ²	Removable tinned copper 300 mm ²
Cable connection	Clamping ring	Clamping ring
Impulse withstand voltage (kV)	55	55
AC withstand voltage (kV)	25	25
DC withstand voltage (kV)	25	25
Short circuit current (kA/1s)	40	40
Description	HVLB-E-C-0-3-2-68	HVLB-C-C-x*-3-2-68

* indicates voltage class of the sheath voltage limiter (SVL)

About TE Connectivity

TE Connectivity is a global, \$14 billion company that designs and manufactures approximately 500,000 products that connect and protect the flow of power and data inside the products that touch every aspect of our lives. Our nearly 100,000 employees partner with customers in virtually every industry – from consumer electronics, energy and healthcare, to automotive, aerospace and communication networks – enabling smarter, faster, better technologies to connect products to possibilities.

While TE Connectivity (TE) has made every reasonable effort to ensure the accuracy of the information in this catalog, TE does not guarantee that it is error-free, nor does TE make any other representation, warranty or guarantee that the information is accurate, correct, reliable or current. TE reserves the right to make any adjustments to the information contained herein at any time without notice. TE expressly disclaims all implied warranties regarding the information contained herein, including, but not limited to, any implied warranties of merchantability or fitness for a particular purpose. The dimensions in this catalog are for reference purposes only and are subject to change without notice. Specifications are subject to change without notice. Consult TE for the latest dimensions and design specifications. Raychem, Raychem (logo), TE Connectivity and TE Connectivity (logo) are trademarks.

TE Energy – innovative and economical solutions for the electrical power industry: cable accessories, connectors & fittings, insulators & insulation, surge arresters, switching equipment, street lighting, power measurement and control.

Tyco Electronics Raychem GmbH
a TE Connectivity Ltd. Company
Finsinger Feld 1
85521 Ottobrunn/Munich, Germany

Phone: +49-89-6089-0
Fax: +49-89-6096345

energy.te.com

