



Aluminium

## Zoom Camera for hazardous areas

# EC-740-AFZ-EX-ALU/SST

This zoom camera provides day and night surveillance for outdoor areas. The wide range zoom allows a 18x enlargement of the hazardous area. In combination with the specific oil damper (optional accessory) this camera is the ideal crane accessory for harsh areas. Two versions are available, the 316 stainless steel enclosure is the ideal offshore application and the aluminium enclosure if a light weight solution is demanded.



Stainless steel

## Hardware Types

- EC-740-AFZ-EX-SST Stainless Steel Enclosure
- EC-740-AFZ-EX-ALU Aluminium Enclosure

## Hardware Features

- Front glass hardened for scratch protection.
- Heated lenses offer protection against condensation and frost.
- The temperature range of  $-40^{\circ}\text{C}$  up to  $+75^{\circ}\text{C}$  allows worldwide operation without additional enclosures.
- Zone 1,2,21,22 (Gas/Dust)

## Operation Principle

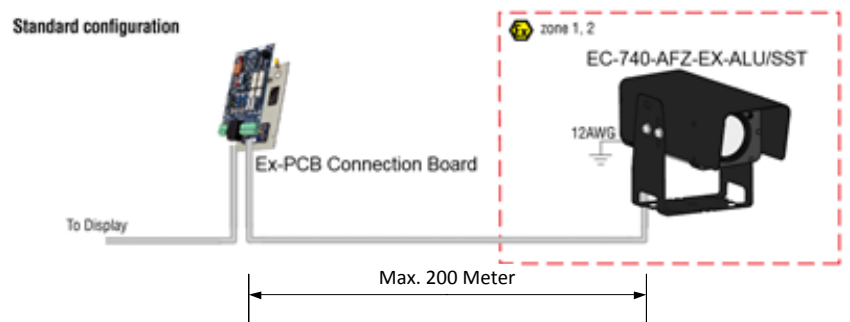

**NOTE:** For more installation and specification details see the Installation manual.

## Explosion Protection:

### Explosion Protection Identification



ATEX 13ATEX1536X  
IECEX NEM 13.0026X

II 2G Ex ib mb px IIC T4 Gb  $T_{amp} -40^{\circ}\text{C}$  to  $+75^{\circ}\text{C}$   
 II 2D Ex mb tb IIIC T102°C Db  $T_{amp} -40^{\circ}\text{C}$  to  $+75^{\circ}\text{C}$   
 II(2)G [Ex ib mb px Gb] IIC

## Temperature Range:

$-40^{\circ}\text{C}$  to  $+75^{\circ}\text{C}$

## IP Protection:

IP69K

# Zoom Camera EC-740-AFZ-EX-ALU/SST series



Data sheet 2013 | R1-0 | EN

## Technical Data

CCD sensor	1/4" type IT CCD (EX view HAD)
Picture elements	752 (H) x 582 (V) (ca. 440 000 pixels)
Resolution	PAL 460 TVL (wide end)
Lens	F = 4,1 mm (wide) to 73,8 mm (tele). 216 x zoom ratio; 18 x zoom, 12 x digital. F=1,4 to F=3,0
Lens speed	From wide optical to tele (optical) 2,1 sec.
Angle of view (H)	48° (wide) to 2,8° (tele end)
Min. working distance	290mm (wide end), 800 mm (tele end)
Min. illumination	0,1 Lux (F1,4 1/3 sec. PAL)
Day/Night function	IR Cut filter (ICR)
S/N ratio	50 dB or more
TV system	PAL, CVBS, 625 lines interlaced, 50 Hz, 4,43 MHz color subcarrier 1 Vtt (75 ohm)
ALU Housing	Sun cover and housing: Aluminium (AlMgSi1). Bracket and mounting parts: SST 316
SST Housing	Sun cover and housing: Stainless Steel 316. Bracket and mounting parts: SST 316
Protection	IP66/67 following IEC 60529. 1,4 Bar overpressure filled with dry nitrogen, monitored by two absolute sensors, long term stability 0,1%/year. Camera is also successfully tested IP69K following DIN 40050-9: camera can withstand a high pressure cleaning with water: 14-16L/min. 80°C and 100 bars flow.
Bracket	Standard bracket, including bolts, nuts and washers. Suitable for mounting hanging, overhead and standing.
Operation temperature	EC-740-AFZ-EX-ALU; T-amb. -40°C to +75°C. EC-740-AFZ-EX-SST; T-amb. -40°C to +75°C.
Glass	Chemically hardened lens glass, 7x stronger than ordinary glass, scratch proof surface, following "VII Flachgläser" (German std.).
Weight aluminium	3 kg (including 5 m cable)
Weight stainless steel	6 kg (including 5 m cable)
Power input	24V/DC +/-10%.
Power consumption	Temperature <0°C (heater on): 5,6W. Temperature >0°C (heater off): 3,6 W.
Fuse	The camera must be protected with a 315 mA-T fuse, with 1500A breaking capacity. Placed on the Ex board, see Installation manual.
Communication	RS 232 Visca protocol 9,6 Kbps or RS 232 Pelco D 9,6 Kbps
Cable	Min. cable bending radius 50mm.
Electric parameters	Um = 30V/DC.
Optional accessory	Oil damped bracket for crane application, 7" or 15" Ex d display unit, VB-CAM-MULTI-01-ARM, VB-CAM-MULTI-01-UNI, Video server

## Dimensions (Units in mm)

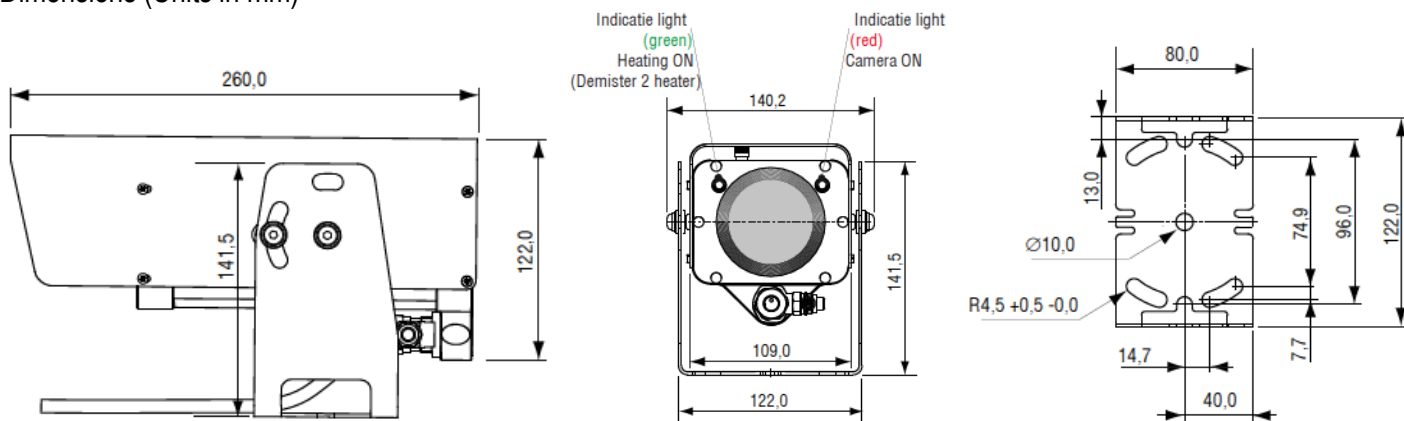

We reserve the right to make any changes at any time according to technological progress or further development.



WWW.CABLEJOINTS.CO.UK  
**THORNE & DERRICK UK**  
 TEL 0044 191 490 1547 FAX 0044 477 5371  
 TEL 0044 117 977 4647 FAX 0044 977 5582