

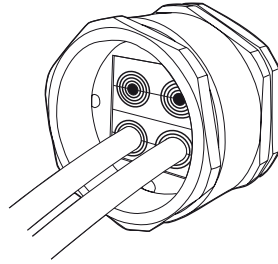

WWW.CABLEJOINTS.CO.UK  
**THORNE & DERRICK UK**  
 TEL 0044 191 490 1547 FAX 0044 477 5371  
 TEL 0044 117 977 4647 FAX 0044 977 5582  
 WWW.THORNEANDDERRICK.CO.UK



## Installation instructions Roxtec RG M63

### RG M63/1

- 1 piece Compression screw
- 1 piece Front washer
- 1 piece Gland Module 40 10-32
- 1 piece Compression rubber
- 1 piece Rear washer
- 1 piece Seal washer
- 1 piece Housing
- 1 piece O-ring
- 1 piece Lock nut
- 1 piece Lubricant

### RG M63/4

- 1 piece Compression screw
- 1 piece Front washer
- 2 pcs Gland Module 20w40
- 1 piece Compression rubber
- 1 piece Rear washer
- 1 piece Seal washer
- 1 piece Housing
- 1 piece O-ring
- 1 piece Lock nut
- 1 piece Lubricant

### RG M63/9

- 1 piece Compression screw
- 1 piece Front washer
- 3 pcs Gland Module 13.3w40
- 1 piece Compression rubber
- 1 piece Rear washer
- 1 piece Seal washer
- 1 piece Housing
- 1 piece O-ring
- 1 piece Lock nut
- 1 piece Lubricant

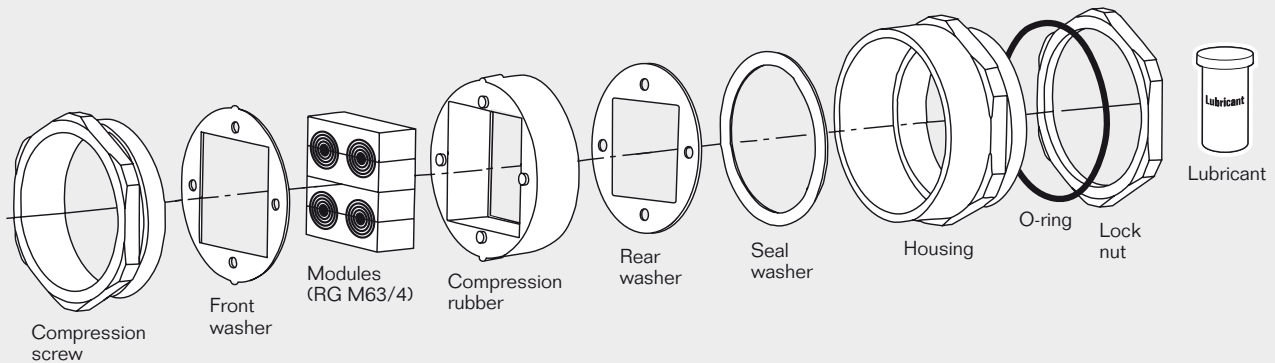

### RG M63 installation

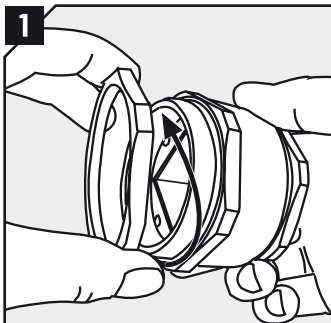

1 Separate the lock nut from the gland housing.

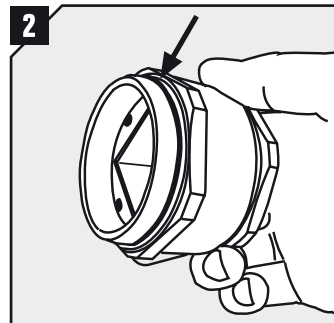

2 Check that the O-ring is in the right place.

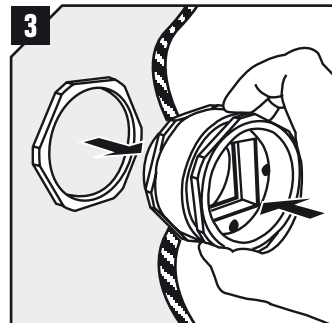

3 Insert the gland in the hole. Fasten it with the lock nut. Hole dimensions 63–64 mm. Max wall thickness 4 mm.

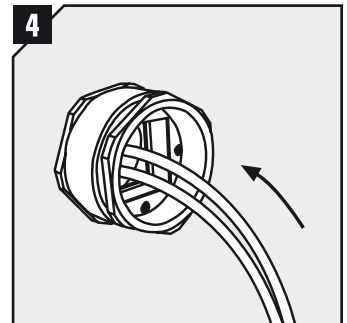

4 Pull all the cables through.

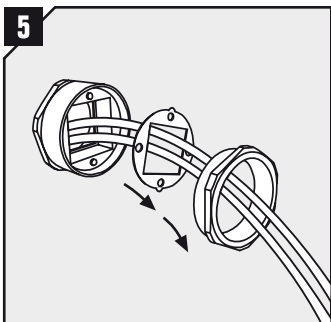

5 Remove the compression screw and the front washer.

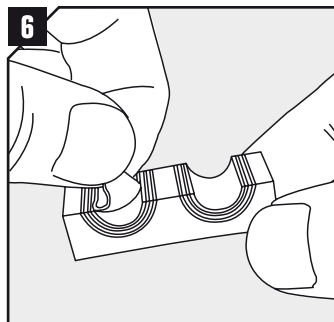

6 Adapt modules which are to hold cables by peeling off layers until you reach the gap seen in pic. 7. The halves may not differ by more than one layer.

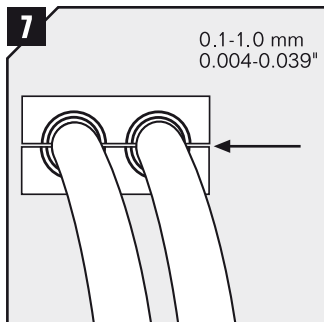

7 Achieve a 0.1-1.0 mm gap between the two halves when held against the cable.

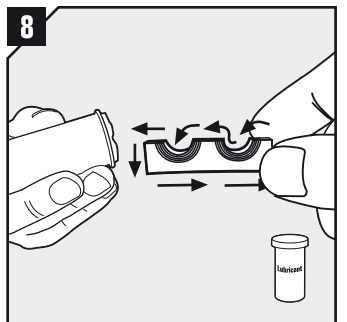

8 Lubricate all modules for the frame thoroughly with Roxtec Lubricant, both the inside and the outside surfaces.



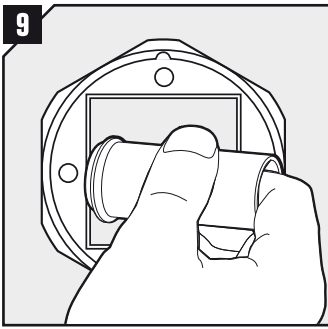

9 Lubricate the compression rubber. Especially in the corners.

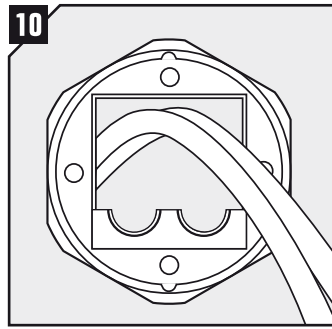

10 Start by placing a module half at the bottom.

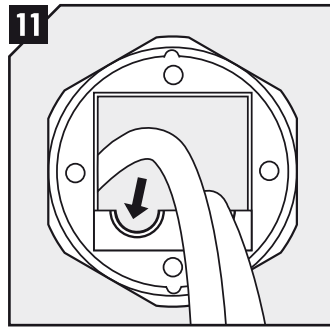

11 Place the cables in the adapted modules.

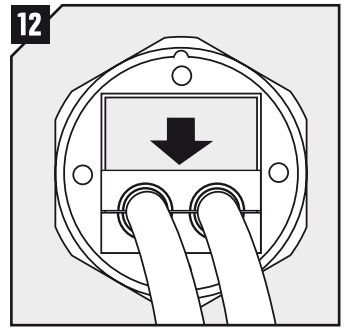

12 Add the second module half on top.

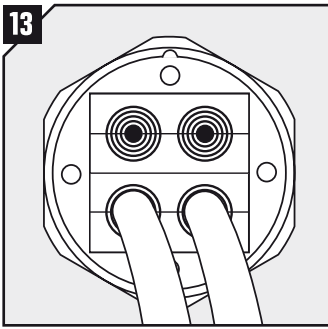

13 Repeat step 10-12 until the packing space is filled.

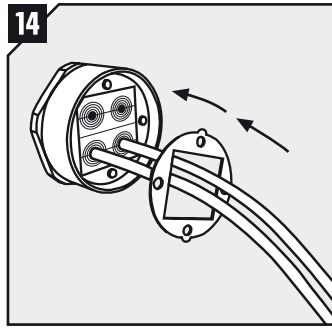

14 Put the front washer back in place. Make sure that locating tabs are properly inserted in housing grooves.

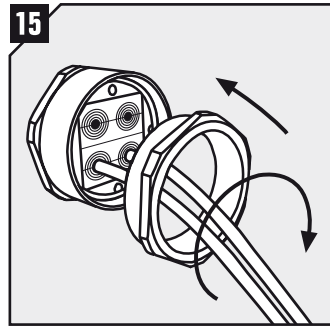

15 Reinstall the compression screw. Tighten approx. 35 Nm.

## Note

- For optimum reliability, wait 24 hours or longer after installation before exposing the cables/pipes to strain or pressure.
- To be used with: GM components.
- Cables passing through the seal shall be perpendicular to the visible module surface.

## Disassembly

Reverse order.

## DISCLAIMER

"The Roxtec cable entry sealing system ("the Roxtec system") is a modular-based system of sealing products consisting of different components. Each and every one of the components is necessary for the best performance of the Roxtec system. The Roxtec system has been certified to resist a number of different hazards. Any such certification, and the ability of the Roxtec system to resist such hazards, is dependent on all components that are installed as a part of the Roxtec system. Thus, the certification is not valid and does not apply unless all components installed as part of the Roxtec system are manufactured by or under license from Roxtec ("authorized manufacturer"). Roxtec gives no performance guarantee with respect to the Roxtec system, unless (i) all components installed as part of the Roxtec system are manufactured by an authorized manufacturer and (ii) the purchaser is in compliance with (a), and (b), below.

(a) During storage, the Roxtec system or part thereof, shall be kept indoors in its original packaging at room temperature.

(b) Installation shall be carried out in accordance with Roxtec installation instructions in effect from time to time.

The product information provided by Roxtec does not release the purchaser of the Roxtec system, or part thereof, from the obligation to independently determine the suitability of the products for the intended process, installation and/or use.

Roxtec gives no guarantee for the Roxtec system or any part thereof and assumes no liability for any loss or damage whatsoever, whether direct, indirect, consequential, loss of profit or otherwise, occurred or caused by the Roxtec systems or installations containing components not manufactured by an authorized manufacturer.

Roxtec expressly excludes any implied warranties of merchantability and fitness for a particular purpose and all other express or implied representations and warranties provided by statute or common law. User determines suitability of the Roxtec system for intended use and assumes all risk and liability in connection therewith. In no event shall Roxtec be liable for consequential, punitive, special, exemplary or incidental damages."



Roxtec International AB  
 Box 540, 371 23 Karlskrona, SWEDEN  
 PHONE +46 455 36 67 00, FAX +46 455 820 12  
 EMAIL info@roxtec.com, www.roxtec.com