

Surge Arresters

POLIM-S Datasheet



WWW.CABLEJOINTS.CO.UK
THORNE & DERRICK UK
TEL 0044 191 490 1547 FAX 0044 477 5371
TEL 0044 117 977 4647 FAX 0044 977 5582
WWW.THORNEANDDERRICK.CO.UK





Technical Data

The POLIM-S surge arresters are designed and tested according to IEC 60099-4 : 2004

- For system voltages up to	36 kV rms	- Long duration current impulse	1000 A / 2000 μs
- Nominal discharge current I_n 8/20 μs	10 kA pk	- Energy capability, 2 impulses	9.0 kJ / kV of U_c
- High current impulse I_{hc} 4/10 μs	100 kA pk	- Energy input with I_{hc}	3.6 kJ / kV of U_c
- Short circuit rating I_s 50 Hz	50 kA rms for 0.2s	- Power frequency up to	62 Hz
- Line discharge class according to IEC 60099-4	3	- Cantilever strength 'MPSL'	4000 Nm
- Classification according to IEEE (ANSI) C62.11	station class	- Torsional strength	100 Nm
- Service conditions:		- Vertical load	3000 N
- temperature (1)	- 60°C up to + 45°C		
- altitude (2)	up to 1800 m		

(1) These values exceed IEC requirements. For installations in higher ambient temperatures, please contact the manufacturer.

(2) This value exceeds IEC requirements. For installations in higher altitudes, please contact the manufacturer.

Application

Protection of medium voltage AC networks against both, multiple atmospheric and switching overvoltages as well as Very Fast Transients (VFT). Suitable for the protection of transformers, transformers in arc furnace applications, cables, generators, parallel to capacitor banks, and railway vehicles. Can be used mechanically as support insulator or as suspension insulator in case of application as line arrester. For indoor and outdoor installation.

Advantages

- Low residual voltage
- Long protection distance
- High energy absorption capacity
- Maintenance free
- Stable U-I characteristics even after multiple strokes
- Proof against ageing
- Explosion and shatter-resistant design
- Stable against shock and vibrations
- Pollution resistant and UV-stable
- Housing resistant to rough handling
- Stable against shock and vibration
- High mechanical resistance

Electrical Data for POLIM-S

U_c Continuous operating voltage kV _{rms}	U_r Rated voltage kV _{rms}	Residual voltage (U_{res}) in kV peak at a specified impulse current								
		wave 1/ ... μs at		wave 8/20 μs at				wave 30/60 μs at		
		5 kA _{peak}	10 kA _{peak}	1 kA _{peak}	5 kA _{peak}	10 kA _{peak}	20 kA _{peak}	500 A _{peak}	1 kA _{peak}	2 kA _{peak}
4	5.0	12.8	13.7	10.5	11.4	12.0	13.2	9.9	10.2	10.5
5	6.3	15.9	17.1	13.1	14.3	15.0	16.5	12.3	12.7	13.2
6	7.5	19.1	20.6	15.7	17.1	18.0	19.8	14.8	15.3	15.8
7	8.8	22.3	24.0	18.3	20.0	21.0	23.0	17.3	17.8	18.4
8	10.0	25.5	27.4	20.9	22.8	24.0	26.3	19.7	20.3	21.0
9	11.3	28.7	30.8	23.5	25.7	27.0	29.6	22.2	22.9	23.7
10	12.5	31.8	34.2	26.1	28.5	30.0	32.9	24.6	25.4	26.3
11	13.8	35.0	37.7	28.8	31.4	33.0	36.2	27.1	27.9	28.9
12	15.0	38.2	41.1	31.4	34.2	36.0	39.5	29.6	30.5	31.5
13	16.3	41.4	44.5	34.0	37.1	39.0	42.8	32.0	33.0	34.2
14	17.5	44.6	47.9	36.6	39.9	42.0	46.0	34.5	35.5	36.8
15	18.8	47.7	51.3	39.2	42.8	45.0	49.3	36.9	38.1	39.4
16	20.0	50.9	54.8	41.8	45.6	48.0	52.6	39.4	40.6	42.0
17	21.3	54.1	58.2	44.4	48.5	51.0	55.9	41.9	43.1	44.7
18	22.5	57.3	61.6	47.0	51.3	54.0	59.2	44.3	45.7	47.3
19	23.8	60.5	65.0	49.6	54.2	57.0	62.5	46.8	48.2	49.9
20	25.0	63.6	68.4	52.2	57.0	60.0	65.7	49.2	50.7	52.5
21	26.3	66.8	71.9	54.9	59.9	63.0	69.0	51.7	53.3	55.2
22	27.5	70.0	75.3	57.5	62.7	66.0	72.3	54.2	55.8	57.8
23	28.8	73.2	78.7	60.1	65.6	69.0	75.6	56.6	58.4	60.4
24	30.0	76.4	82.1	62.7	68.4	72.0	78.9	59.1	60.9	63.0
25	31.3	79.5	85.5	65.3	71.3	75.0	82.2	61.5	63.4	65.7
26	32.5	82.7	89.0	67.9	74.1	78.0	85.5	64.0	66.0	68.3
27	33.8	85.9	92.4	70.5	77.0	81.0	88.7	66.5	68.5	70.9
28	35.0	89.1	95.8	73.1	79.8	84.0	92.0	68.9	71.0	73.5
29	36.3	92.3	99.2	75.7	82.7	87.0	95.3	71.4	73.6	76.2
30	37.5	95.4	102.6	78.3	85.5	90.0	98.6	73.8	76.1	78.8
31	38.8	98.6	106.1	81.0	88.4	93.0	101.9	76.3	78.6	81.4
32	40.0	101.8	109.5	83.6	91.2	96.0	105.2	78.8	81.2	84.0
33	41.3	105.0	112.9	86.2	94.1	99.0	108.5	81.2	83.7	86.7
34	42.5	108.2	116.3	88.8	96.9	102.0	111.7	83.7	86.2	89.3
35	43.8	111.3	119.7	91.4	99.8	105.0	115.0	86.1	88.8	91.9
36	45.0	114.5	123.2	94.0	102.6	108.0	118.3	88.6	91.3	94.5
37	46.3	117.7	126.6	96.6	105.5	111.0	121.6	91.1	93.8	97.2
38	47.5	120.9	130.0	99.2	108.3	114.0	124.9	93.5	96.4	99.8
39	48.8	124.1	133.4	101.8	111.2	117.0	128.2	96.0	98.9	102.4
40	50.0	127.2	136.8	104.4	114.0	120.0	131.4	98.4	101.4	105.0
41	51.3	130.4	140.3	107.1	116.9	123.0	134.7	100.9	104.0	107.7
42	52.5	133.6	143.7	109.7	119.7	126.0	138.0	103.4	106.5	110.3
43	53.8	136.8	147.1	112.3	122.6	129.0	141.3	105.8	109.1	112.9
44	55.0	140.0	150.5	114.9	125.4	132.0	144.6	108.3	111.6	115.5

Temporary Overvoltage Capability (TOV) - Power Frequency versus Time Characteristic

- POLIM-S during 1 second (a: 1.437 x Uc or b: 1.375 x Uc)
- POLIM-S during 3 seconds (a: 1.410 x Uc or b: 1.341 x Uc)
- POLIM-S during 10 seconds (a: 1.366 x Uc or b: 1.310 x Uc)
- a: value tested with a sample that has not been prestressed by any energy input.
- b: value tested with a sample that has been prestressed with a prior energy input according to the operating duty test
- The values have been determined with a test sample preheated at 60 deg. Celsius acc. to IEC 60099-4 and refer to an ambient temp. up to 45 deg.Celsius

Dimensions and Clearances

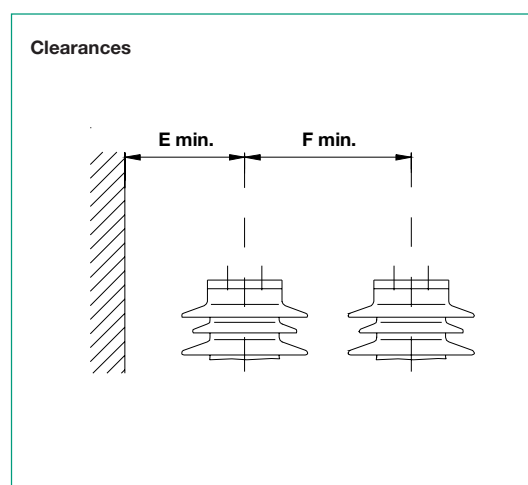
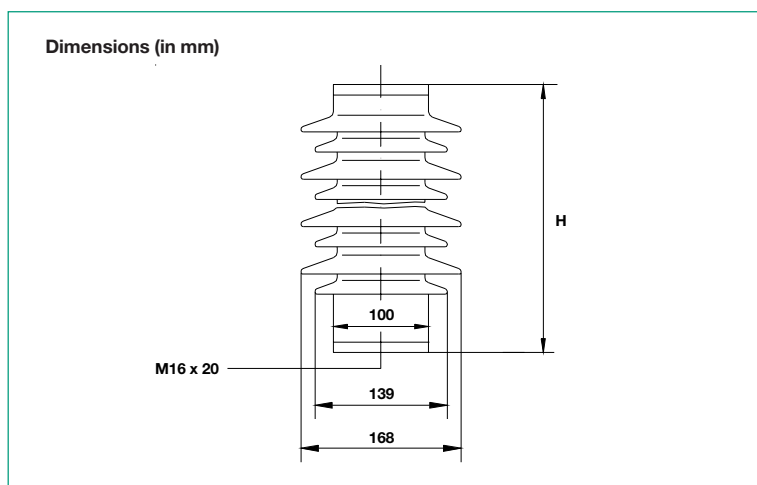

Insulation Data Dimensions and Weight

Type	Creepage distance mm	Flashover distance mm	Recommended clearances		Height H mm	Weight kg	Insulation withstand voltage of empty housing	
			E min. mm	F min. mm			BIL 1.2/50 μ s tested values kV _{peak}	50 Hz 60 s wet tested values kV _{rms}
04	327	176	87	170	210	4.5	131	10
05	327	176	97	170	210	4.6	131	10
06	484	226	106	170	240	5.2	168	16
07	484	226	115	170	240	5.2	168	16
08	484	226	125	176	240	5.3	168	16
09	640	276	134	186	290	6.3	205	23
10	640	276	143	195	290	6.4	205	23
11	640	276	153	205	290	6.5	205	23
12	640	276	162	214	290	6.5	205	23
13	867	347	171	224	360	7.8	225	38
14	867	347	181	233	360	7.9	225	38
15	867	347	190	243	360	7.9	225	38
16	867	347	199	253	360	8.0	225	38
17	867	347	209	262	360	8.1	225	38
18	867	347	218	272	360	8.2	225	38
19	867	347	227	281	360	8.3	225	38
20	867	347	237	291	360	8.4	225	38
21	1024	397	246	300	410	9.3	257	48
22	1024	397	255	310	410	9.4	257	48
23	1024	397	265	319	410	9.5	257	48
24	1024	397	274	329	410	9.5	257	48
25	1024	397	283	338	410	9.6	257	48
26	1180	447	293	348	460	10.6	283	56
27	1180	447	302	357	460	10.7	283	56
28	1180	447	311	367	460	10.7	283	56
29	1180	447	321	376	460	10.8	283	56
30	1423	526	330	386	540	12.3	333	69
31	1423	526	339	395	540	12.4	333	69
32	1423	526	349	405	540	12.5	333	69
33	1423	526	358	415	540	12.5	333	69
34	1423	526	367	424	540	12.6	333	69
35	1423	526	377	434	540	12.7	333	69
36	1423	526	386	443	540	12.8	333	69
37	1650	597	395	453	610	14.0	387	76
38	1650	597	405	462	610	14.1	387	76
39	1650	597	414	472	610	14.2	387	76
40	1650	597	423	481	610	14.3	387	76
41	1736	626	433	491	640	14.8	397	84
42	1736	626	442	500	640	14.9	397	84
43	1736	626	451	510	640	15.0	397	84
44	1736	626	460	519	640	15.1	397	84

The manufacturer reserves the right to change technical data or design without prior notice

ABB

ABB Switzerland Ltd.



WWW.CABLEJOINTS.CO.UK
THORNE & DERRICK UK
TEL 0044 191 490 1547 FAX 0044 477 5371
TEL 0044 117 977 4647 FAX 0044 977 5582
WWW.THORNEANDDERRICK.CO.UK