



## Technical data

- For system voltages up to	36 kV rms	- Long duration current impulse	550 A / 2000 µs
- Nominal discharge current $I_n$ 8/20 µs	10 kA pk	- Energy capability, 2 impulses acc. IEC clause 7.5.5	5.5 kJ / kV of Uc
- High current impulse $I_{hc}$ 4/10 µs	100 kA pk	- Energy input with $I_{hc}$	3.4 kJ / kV of Uc
- Short circuit rating (1) $I_s$ 50 Hz	20 kA rms for 0.2s	- Power frequency up to	62 Hz
- Line discharge class according to IEC 60099-4	2	- Cantilever strength	350 Nm
- Service conditions: temperature (2)	- 60°C up to + 45°C	- Torsional strength	68 Nm
- Altitude (3)	up to 1800 m	- Vertical load	1200 N

(1) Tested value acc. IEC 60099-4.

(2) These values exceed IEC requirements. For installations in higher ambient temperatures, please contact the manufacturer.

(3) This value exceeds IEC requirements. For installations in higher altitudes, please contact the manufacturer.

## Application

Protection of medium voltage AC networks against both, multiple atmospheric and switching overvoltages as well as Very Fast Transients (VFT). Suitable for instance for the protection of transformers, cables, motors and other medium voltage equipment. For indoor and outdoor installation. Also available with increased creepage distance (MWK..K4).

## Advantages

- Low residual voltage
- Long protection distance
- High energy input capacity
- Stable U-I characteristics even after multiple strokes
- Proof against ageing
- Explosion and shatter-resistant design
- Pollution resistant and UV-stable
- Housing resistant to rough handling
- Maintenance free
- Stable against shock and vibration
- High mechanical resistance

## Temporary overvoltage capability (TOV) - Power frequency versus time characteristic

- During 1 second (a: 1.362 x Uc or b: 1.317 x Uc)
- During 3 seconds (a: 1.337 x Uc or b: 1.287 x Uc)
- During 10 seconds (a: 1.310 x Uc or b: 1.256 x Uc)
- a: value tested with a sample that has not been prestressed by any energy input.
- b: value tested with a sample that has been prestressed with a prior energy input according to the operating duty test
- The values have been determined with a test sample preheated at 60 degrees Celsius according to IEC 60099-4 and refer to an ambient temperature up to 45 degrees Celsius.

## Guaranteed data

Type MWK	U <sub>r</sub> Rated voltage kV rms	U <sub>c</sub> Continuous operating voltage kV rms	Residual voltage (U <sub>res</sub> ) in kV pk at a specified impulse current										
			Wave 1/.. µs			Wave 8/20 µs				Wave 30/60 µs			
			1 kA pk	5 kA pk	10 kA pk	1 kA pk	5 kA pk	10 kA pk	20 kA pk	125 A pk	250 A pk	500 A pk	1 kA pk
04	5.0	4	10.5	12.8	14.5	10.4	11.6	12.3	13.6	9.0	9.5	9.8	10.2
05	6.3	5	13.1	16.0	18.1	13.0	14.5	15.4	17.0	11.3	11.9	12.3	12.8
06	7.5	6	15.7	19.2	21.7	15.6	17.4	18.4	20.4	13.6	14.3	14.8	15.4
07	8.8	7	18.3	22.4	25.3	18.2	20.3	21.5	23.8	15.8	16.7	17.2	17.9
08	10.0	8	21.0	25.6	29.0	20.8	23.2	24.6	27.2	18.1	19.0	19.7	20.5
09	11.3	9	23.6	28.9	32.6	23.4	26.1	27.6	30.6	20.3	21.4	22.1	23.0
10	12.5	10	26.2	32.1	36.2	26.0	29.0	30.7	34.0	22.6	23.8	24.6	25.6
11	13.8	11	28.8	35.3	39.8	28.6	31.9	33.8	37.4	24.9	26.2	27.1	28.2
12	15.0	12	31.4	38.5	43.4	31.2	34.8	36.8	40.8	27.1	28.6	29.5	30.7
13	16.3	13	34.1	41.7	47.1	33.8	37.7	39.9	44.2	29.4	30.9	32.0	33.3
14	17.5	14	36.7	44.9	50.7	36.4	40.6	43.0	47.6	31.7	33.3	34.5	35.8
15	18.8	15	39.3	48.1	54.3	39.0	43.5	46.1	51.0	33.9	35.7	36.9	38.4
16	20.0	16	41.9	51.3	57.9	41.6	46.4	49.1	54.4	36.2	38.1	39.4	41.0
17	21.3	17	44.5	54.5	61.5	44.2	49.3	52.2	57.8	38.4	40.5	41.8	43.5
18	22.5	18	47.2	57.7	65.2	46.8	52.2	55.3	61.2	40.7	42.9	44.3	46.1
19	23.8	19	49.8	60.9	68.8	49.4	55.1	58.3	64.6	43.0	45.2	46.8	48.6
20	25.0	20	52.4	64.1	72.4	52.0	58.0	61.4	68.0	45.2	47.6	49.2	51.2
21	26.3	21	55.0	67.3	76.0	54.6	60.9	64.5	71.4	47.5	50.0	51.7	53.8
22	27.5	22	57.6	70.5	79.6	57.2	63.8	67.5	74.8	49.7	52.4	54.1	56.3
23	28.8	23	60.3	73.7	83.3	59.8	66.7	70.6	78.2	52.0	54.8	56.6	58.9
24	30.0	24	62.9	76.9	86.9	62.4	69.6	73.7	81.6	54.3	57.1	59.1	61.4
25	31.3	25	65.5	80.1	90.5	65.0	72.5	76.8	85.0	56.5	59.5	61.5	64.0
26	32.5	26	68.1	83.4	94.1	67.6	75.4	79.8	88.4	58.8	61.9	64.0	66.5
27	33.8	27	70.7	86.6	97.7	70.2	78.3	82.9	91.8	61.0	64.3	66.4	69.1
28	35.0	28	73.4	89.8	101.4	72.8	81.2	86.0	95.2	63.3	66.7	68.9	71.7
29	36.3	29	76.0	93.0	105.0	75.4	84.1	89.0	98.6	65.6	69.0	71.4	74.2
30	37.5	30	78.6	96.2	108.6	78.0	87.0	92.1	102.0	67.9	71.4	73.8	76.8
31	38.8	31	81.2	99.4	112.2	80.6	89.9	95.2	105.4	70.1	73.8	76.3	79.3
32	40.0	32	83.9	102.6	115.8	83.2	92.8	98.2	108.8	72.3	76.2	78.7	81.9
33	41.3	33	86.5	105.8	119.5	85.8	95.7	101.3	112.2	74.6	78.6	81.2	84.5
34	42.5	34	89.1	109.0	123.1	88.4	98.6	104.4	115.5	76.9	80.9	83.7	87.0
35	43.8	35	91.7	112.2	126.7	91.0	101.5	107.5	118.9	79.1	83.3	86.1	89.6
36	45.0	36	94.3	115.4	130.3	93.6	104.4	110.5	122.3	81.4	85.7	88.6	92.1
37	46.30	37	97.0	118.6	134.0	96.2	107.3	113.6	125.7	83.7	88.1	91.1	94.7
38	47.50	38	99.6	121.8	137.6	98.8	110.2	116.7	129.1	85.9	90.5	93.5	97.3
39	48.80	39	102.2	125.0	141.2	101.4	113.1	119.7	132.5	88.2	92.8	96.0	99.8
40	50.00	40	104.8	128.2	144.8	104.0	116.0	122.8	135.9	90.4	95.2	98.4	102.4
41	51.30	41	107.4	131.4	148.4	106.6	118.9	125.9	139.3	92.7	97.6	100.9	104.9
42	52.50	42	110.1	134.6	152.1	109.2	121.8	128.9	142.7	95.0	100.0	103.4	107.5
43	53.80	43	112.7	137.9	155.7	111.8	124.7	132.0	146.1	97.2	102.4	105.8	110.1
44	55.0	44	115.2	141.0	159.2	114.4	127.6	135.0	149.6	99.4	104.8	108.2	112.6

## Dimensions (in mm)

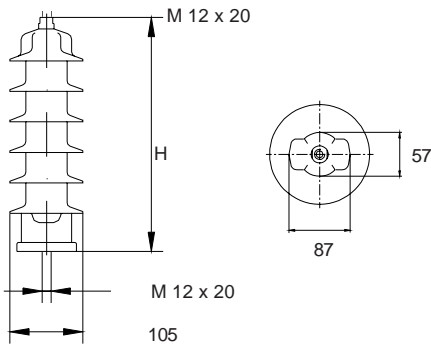

## Clearances

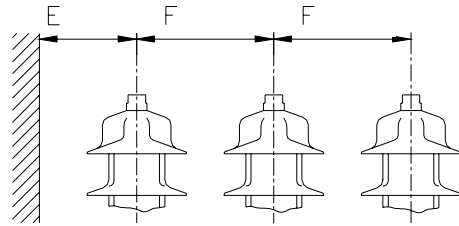

## Insulation data, dimensions and weight

Type	Creepage distance mm	Flashover distance mm	Recommended clearances (4)		Height H mm	Weight kg	Insulation withstand voltage of empty housing			
			E min mm	F min mm			BIL 1.2/50 $\mu$ s		50 Hz 60s wet	
							req. values acc. to IEC kV pk	tested values kV pk	req. values acc. to IEC kV rms	tested values kV rms
04	269	183	51	60	187	1.3	16.0	90	7.4	28.0
05	269	183	61	71	187	1.4	20.0	90	9.3	28.0
06	269	183	71	81	187	1.4	24.0	90	11.1	28.0
07	269	183	81	91	187	1.5	28.0	90	13.0	28.0
08	269	183	91	101	187	1.5	32.0	90	14.8	28.0
09	344	223	101	111	227	1.9	36.0	112	16.7	36.0
10	344	223	112	121	227	1.9	40.0	112	18.5	36.0
11	418	263	122	131	267	2.2	44.0	132	20.3	43.0
12	418	263	132	141	267	2.2	47.9	132	22.2	43.0
13	418	263	142	152	267	2.3	51.9	132	24.0	43.0
14	418	263	152	162	267	2-3	55.9	132	25.9	43.0
15	418	263	162	172	267	2.4	59.9	132	27.7	43.0
16	492	303	172	182	307	2.7	63.9	152	29.6	50.0
17	492	303	183	192	307	2.7	67.9	152	31.4	50.0
18	492	303	193	202	307	2.8	71.9	152	33.3	50.0
19	492	303	203	212	307	2.8	75.9	152	35.1	50.0
20	492	303	213	222	307	2.9	79.9	152	36.9	50.0
21	567	343	223	233	347	3.2	83.9	172	38.8	56.0
22	567	343	233	243	347	3.2	87.9	172	40.6	56.0
23	567	343	244	253	347	3.3	91.8	172	42.5	56.0
24	567	343	254	263	347	3.3	95.8	172	44.3	56.0
25	641	383	264	273	387	3.6	99.8	192	46.2	62.0
26	641	383	274	283	387	3.6	103.8	192	48.0	62.0
27	641	383	284	293	387	3.7	107.8	192	49.9	62.0
28	641	383	294	303	387	3.7	111.8	192	51.7	62.0
29	641	383	304	313	387	3.8	115.8	192	53.5	62.0
30	641	383	315	324	387	3.8	119.8	192	55.4	62.0
31	865	503	325	334	507	4.7	123.8	252	57.2	82.0
32	865	503	335	344	507	4.7	127.8	252	59.1	82.0
33	865	503	345	354	507	4.8	131.8	252	60.9	82.0
34	865	503	355	364	507	4.8	135.7	252	62.8	82.0
35	865	503	365	374	507	4.9	139.7	252	64.6	82.0
36	865	503	376	384	507	4.9	143.7	252	66.5	82.0
37	865	503	385	394	507	5.0	147.7	252	68.3	82.0
38	865	503	396	404	507	5.0	151.7	252	70.1	82.0
39	865	503	406	414	507	5.1	155.7	252	72.0	82.0
40	865	503	416	424	507	5.1	159.7	252	73.8	82.0
41	865	503	426	435	507	5.2	163.7	252	75.7	82.0
42	939	543	437	444	547	5.2	167.7	252	77.5	82.0
43	939	543	446	454	547	5.4	171.7	252	79.4	82.0
44	939	543	457	465	547	5.4	175.7	252	81.2	82.0

(4) National and local requirements have priority and may be used.



**WWW.CABLEJOINTS.CO.UK**  
**THORNE & DERRICK UK**  
**TEL 0044 191 490 1547 FAX 0044 477 5371**  
**TEL 0044 117 977 4647 FAX 0044 977 5582**  
**WWW.THORNEANDDERRICK.CO.UK**