

750S1, 775S1 & 775T1 INTERFACE E - 5/8" EQUIPMENT BUSHING

Application

For use in equipment insulated with oil fluid, typically for transformers, switch gear, capacitors...

Technical characteristics

Each bushing is tested for AC withstand and partial discharge prior to leaving the factory.

**Up to 36 kV
800 A & 1250 A**

6/10 (12) kV
6.35/11 (12) kV
8.7/15 (17.5) kV
12/20 (24) kV
12.7/22 (24) kV
18/30 (36) kV

Design

The equipment bushing is a moulded epoxy insulated part in accordance with ANSI/IEEE 386 std. (5/8" threading system).

Specifications and standards

The bolted type equipment bushings 750S1, 775S1 and 775T1 meet the requirements of IEC 137.

Ordering instructions

To order the equipment bushing, specify the type.

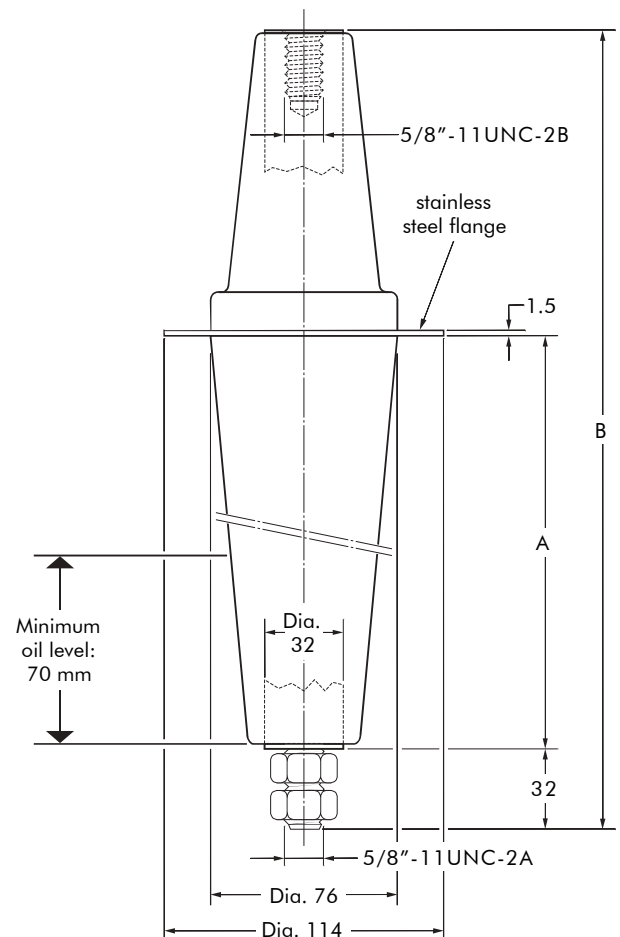

In mm, except where noted.

Equipment bushing type	Voltage U_r (kV)	Current I_r (A)	Dimensions (mm)	
			A	B
750S1	36	800	75	235
775S1	36	1250	75	235
775T1	36	1250	221	378