

CRE1 - Cable to Rebar

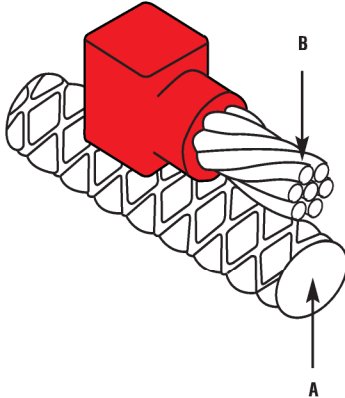

A mm	B mm ²	Weld Powder	Mould	Handle Clamp
10 - 40	16	WEP 045	CRE1-A-16	HCA 001
	25		CRE1-A-25	
	35		CRE1-A-35	
	8mm Ø	WEP 090	CRE1-C-8SC	HCC 004
	50		CRE1-C-50	
	70		CRE1-C-70	
	95		CRE1-C-95	
	120		CRE1-C-120	
	150	WEP 150	CRE1-C-150	HCD 004
	185	WEP 250	CRE1-C-185	
	240	2 x WEP 150	CRE1-D-240	
	300		CRE1-D-300	

To safely and effectively weld cable to rebar some form of mould packing must be used. Preformed ceramic fibre packing (part no. PAK001) or Duxseal (Part no. DXS001) can be used for this purpose.

CRE2 - Cable to Rebar

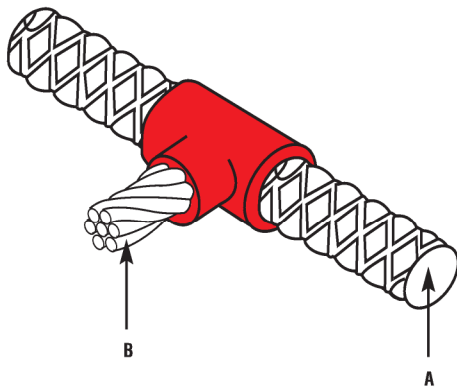

A mm	B mm ²	Weld Powder	Mould	Handle Clamp	
16	16	WEP 090	CRE2-C-16R16	HCC 001	
	25		CRE2-C-16R25		
	35		CRE2-C-16R35		
	50	WEP 115	CRE2-C-16R50	HCC 001	
	8mm Ø		CRE2-C-16R8SC		
	70	WEP 115	CRE2-C-16R70		
	95	WEP 150	CRE2-C-16R95		
	120		CRE2-C-16R120		
	150	WEP 200	CRE2-C-16R150		
	185		CRE2-C-16R185		
	240	WEP 250	CRE2-C-16R240		
	300	2 x WEP 150	CRE2-D-16R300		HCD 001
20	16	WEP 115	CRE2-C-20R16		HCC 001
	25		CRE2-C-20R25		
	35		CRE2-C-20R35		
	50	WEP 150	CRE2-C-20R50	HCC 001	
	8mm Ø		CRE2-C-20R8SC		
	70	WEP 150	CRE2-C-20R70		
	95	WEP 200	CRE2-C-20R95		
	120		CRE2-C-20R120		
	150	WEP 200	CRE2-C-20R150		
	185	WEP 250	CRE2-C-20R185		
	240	2 x WEP 150	CRE2-D-20R240		HCD 001
	300	2 x WEP 200	CRE2-D-20R300		

Table continued on page 25

To safely and effectively weld cable to rebar some form of mould packing must be used. Preformed ceramic fibre packing (part no. PAK001) or Duxseal (Part no. DXS001) can be used for this purpose.

CABLE JOINTS, CABLE TERMINATIONS, CABLE GLANDS, CABLE CLEATS
FEEDER PILLARS, FUSE LINKS, ARC FLASH, CABLE ROLLERS, CUT-OUTS