



CABLE CONNECTION TECHNIQUE

Screw Connectors and Screw Cable
Lugs for Low, Medium and High
Voltage



ARCUS ELEKTROTECHNIK
ALOIS SCHIFFMANN GMBH

Information concerning this catalogue:

All rights reserved for copying of any kind.

All dimensions and pictures are not binding.

We permanently strive to improve products and reserve the right to change design, dimensions or material.

Cable cross sections mentioned refer to DIN VDE 0295.

General

List of Type Numbers	4
Foreword	5
Introduction	6

Low Voltage

Aluminium Screw Connector	7
Aluminium Screw Connector with Tap-Off	10
Aluminium Screw Connector with Insulated Barrel	11
Aluminium Screw Connector for Insulated Cable Conductors	12
Aluminium Screw Connector with Sector-Shaped Clamping Channel	13
Copper Screw Connector	14
Aluminium Screw Cable Lugs	15
Copper Screw Cable Lugs for Screen Wires and Wavecon-cable	16

Medium Voltage

Aluminium Screw Connector, Excentric Design	17
Aluminium Screw Connector, Excentric Design (Reduction Connector)	20
Aluminium Screw Connector, Concentric Design (Reduction Connector)	21
Aluminium Screw Connector with Intelligent Contact Screw, Concentric Design	22
Aluminium Screw Connector for Screen Wires of Cables to VDE and TGL Standards	23
Copper Screw Connector for Copper Screen Wires	24
Aluminium Screw Cable Lugs, Concentric Design	25
Aluminium Screw Cable Lugs with Intelligent Contact Screw, Concentric Design	26
Copper Screw Cable Lugs for Screen Wires and Wavecon-cable	28

High Voltage

Screw Connectors, Mechanical Top Bolts and Bolted Contacts	29
------------------------------------------------------------	----

Installation Tools

Tools for Medium Voltage Cables	31
Insulated Tools	32
Holding Tool	34

List of Type Numbers

General

Type Number Page

108-198

108 016	16,28
108 017	16,28
109 177	32
198 184	32
198 273	16,28
198 381	14,24
198 385	24
198 392	14
198 394	14
198 399	16,28
198 413	14
198 417	16,28
198 423	16,28

208-209

208 032	15
208 033	15
208 034	15
208 036	25
208 038	27
208 039	27
208 040	27
208 041	27
208 042	27
208 043	27
208 044	27
209 011	8
209 012	9
209 013	7
209 018	17
209 019	8
209 020	9
209 024	17
209 025	11
209 026	11
209 027	11
209 028	11
209 050	9
209 052	8
209 056	23
209 058	7
209 065	9
209 067	18
209 069	20
209 072	9
209 075	8
209 078	17
209 079	17
209 080	8
209 081	8
209 082	9
209 083	11
209 084	11
209 085	11

Type Number Page

209-298

209 086	11
209 087	8
209 088	9
209 089	8
209 090	9
209 091	7
209 092	7
209 095	17
209 098	7
209 099	7
209 100	19
209 108	7
209 109	22
209 110	22
209 111	22
209 112	22
209 113	22
209 114	22
209 115	22
209 116	8
209 117	7
209 119	13
209 122	12
209 123	12
209 124	12
209 126	8
209 127	20
209 129	22
209 130	7
209 131	7
209 132	7
209 133	7
209 134	7
209 135	7
209 136	7
209 137	7
298 040	10
298 047	8
298 061	8
298 062	9
298 063	11
298 064	11
298 088	9
298 095	11
298 096	18
298 097	11
298 098	20
298 100	7
298 101	17
298 102	18
298 108	23
298 109	17
298 119	10
298 121	9
298 128	10
298 129	7

Type Number Page

298

298 131	20
298 132	18
298 135	17
298 136	20
298 139	15
298 140	15
298 141	9
298 142	11
298 143	17
298 144	20
298 145	17
298 152	7
298 155	10
298 157	10
298 158	7
298 161	10
298 162	10
298 167	18
298 172	9
298 174	9
298 181	10
298 185	7
298 186	17
298 187	17
298 188	8
298 189	9
298 200	8
298 213	8
298 218	7
298 219	7
298 223	8
298 224	8
298 225	9
298 226	9
298 227	17
298 228	17
298 229	17
298 230	18
298 231	17
298 238	26
298 244	9
298 245	8
298 246	7
298 254	7
298 255	9
298 256	9
298 257	9
298 258	7
298 260	10
298 261	13
298 262	8
298 269	8
298 301	21
298 304	7
298 305	11
298 321	19

Type Number Page

298

298 322	7
298 323	7
298 324	8
298 325	8
298 347	21
298 356	13
298 364	8
298 368	21
298 373	26
298 374	26
298 375	26

612-625

612 003	31
612 003 10	31
612 012	31
612 012 17	31
612 012 18	31
612 012 25	31
612 012 26	31
615 035	31
615 040	33
620 031	32
620 032	32
620 033	32
620 034	32
620 035	32
620 036	32
620 037	32
620 038	32
620 039	32
620 040	32
620 041	32
620 042	32
620 043	32
620 044	32
620 090	32
620 137 05	32
620 137 06	32
620 147	33
620 148	33
620 149	33
620 155	32
620 156	32
620 157	32
620 159	32
620 160	32
622 009	34
625 008	31

Dear reader !

This catalogue will give you an overview of our range of screw connectors, screw cable lugs, and accessories. We have arranged these products in different groups to have them clearly structured and facilitate identification. All important details are listed in a table and supported by illustrations.

In case of uncertainties how to find a product or how to select a suitable one, please contact us. You will find our contact details on the reverse side of this catalogue.

ARCUS Schiffmann offers you a vast range of screw connectors, screw cable lugs, and accessories and furthermore will be pleased to support you in selecting the most suitable product.



This service is a matter of course for us !

For many years now screw connectors and screw cable lugs have not only been an alternative to compression systems but even more they give you additional advantages and possibilities.

To install bolted cable connections means to make a connection with mechanic and electric long-term load properties. This connection needs to be produced by simple means and even under difficult conditions. The quality of this connection must be high enough to ensure reliability for many years.

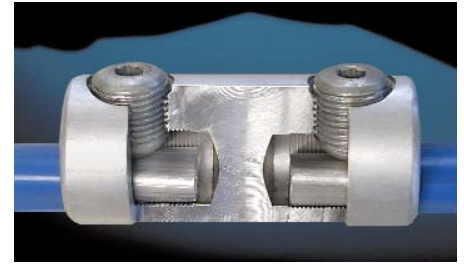

Depending on their specific usage, screw connectors and screw cable lugs are provided with various features which lead to a wide variety of types. Those who have to select from this variety need to make a well informed choice.

The main criteria are voltage level, type of cable conductor, working method, and joint or termination technology.

Apart from the related circumstances there are a number of selection criteria that depend on experience and personal preferences or philosophies of power suppliers.

An overview of the selection criteria of screw connectors and screw cable lugs with the main features as follows:

- Connector barrel Al or Cu
- Connector barrel uncoated, tin-plated, insulated or greased
- Connector barrel with chamfurred or rounded ends
- Connector barrel optional with branch connection for tap-off
- Connector barrel with concentric or excentric clamping channel
- Clamping channel round or sector-shaped
- Clamping channel straight-through or with oil-stop
- Clamping channel plain, grooved or serrated
- One or more contact screws per connector half
- Contact screw with spherical pressure foot or with cutting edges
- Contact screw with or without shear-head
- Shear-head bolt removable or not removable after shear-off
- Multiple or single shear-head bolt
- On cable lugs: type of palm

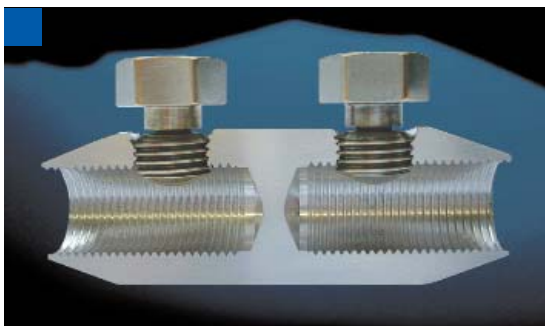

We will not go into any further detail at this point. There are many reasons to prefer or reject certain features.

For instance an oil stop inside a connector may be considered as a helpful stopper during installation but may also be seen as a hinderance because a straight-through movement for easy installation of the second conductor is impossible.

In case you will not find the required product on the following pages - please contact us !

Aluminium Screw Connector

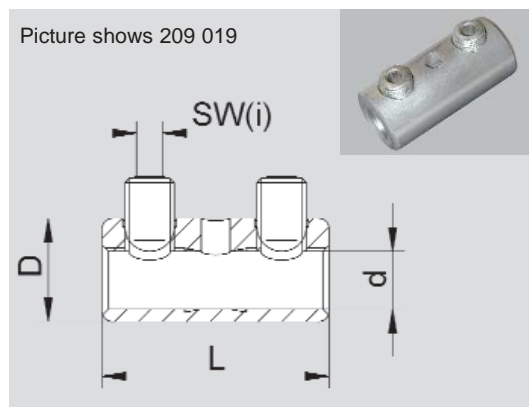
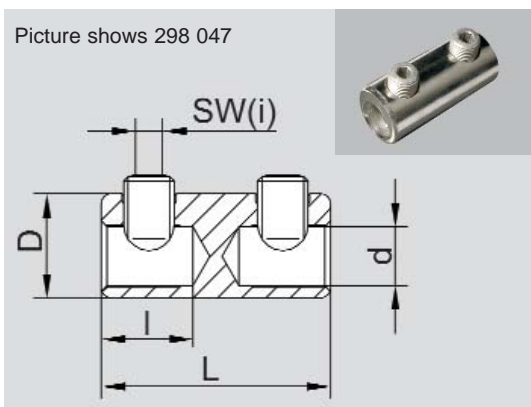

Cross Section [mm ²]	Connector Barrel							Contact Screw					Type Number		
	straight-through	with oil-stop	uncoated	tin-plated	Dimensions [mm]				socket screw	shear-head screw removable	shear-head screw unremovable	number		SW(i) (DIN 475)	torque [Nm]
					D	d	L	l							
6-35 RE 6-25 RM	•		•		14	7.2	40		•			2	4	8	209 013
	•		•		14	7.2	40				•	2	4	8	209 091
	•			•	14	7.2	40		•			2	4	8	298 100
	•			•	14	7.2	40				•	2	4	8	209 092
	•	•		•	14	7.2	40	17.5			•	2	4	8	298 246
Cu 2.5-35 SM / 50 RM(v) Al 6-35 SM / 50 RM(v)	•		•		16	9	40				•	2	4	9	209 098
	•		•		16	9	40		•			2	4	9	209 058
	•			•	16	9	40				•	2	4	9	209 099
	•			•	16	9	40		•			2	4	9	298 152
		•	•		16	9.4	40	17.5			•	2	4	9	209 117
		•	•		16	9.4	40	17.5	•			2	4	9	209 108
		•		•	16	9.4	40	17.5			•	2	4	9	298 219
		•		•	16	9.4	40	17.5	•			2	4	9	298 218
6 RE-50	•		•		18	10.5	40		•			2	5	10	209 130
	•		•		18	10.5	40				•	2	5	10	209 134
	•			•	18	10.5	40		•			2	5	10	209 131
	•			•	18	10.5	40				•	2	5	10	209 135
		•	•		18	10.5	40	17.6	•			2	5	10	209 132
		•	•		18	10.5	40	17.6			•	2	5	10	209 136
		•		•	18	10.5	40	17.6	•			2	5	10	209 133
		•		•	18	10.5	40	17.6			•	2	5	10	209 137
		•		•	18	10.5	40	17.6	•			2	5	10	209 137
10-70 RE 10-70 RM 50-70 SE 35-70 SM	•		•		22	12.5	57		•			2	5	15	298 258
	•		•		22	12.5	57				•	2	5	15	298 158
	•			•	22	12.5	57		•			2	5	15	298 129
	•			•	22	12.5	57				•	2	5	15	298 322
		•	•		22	12.5	57	24	•			2	5	15	298 254
		•	•		22	12.5	57	24			•	2	5	15	298 323
		•		•	22	12.5	57	24	•			2	5	15	298 304
		•		•	22	12.5	57	24			•	2	5	15	298 185
		•		•	22	12.5	57	24	•			2	5	15	298 185

Explanation of cross sections: R=round, S=sectorial, E=solid, M=stranded, (v)=compacted
 Explanation of key sizes of contact screws: SW(i)=inner hexagon

Aluminium Screw Connector (continued)

Low Voltage

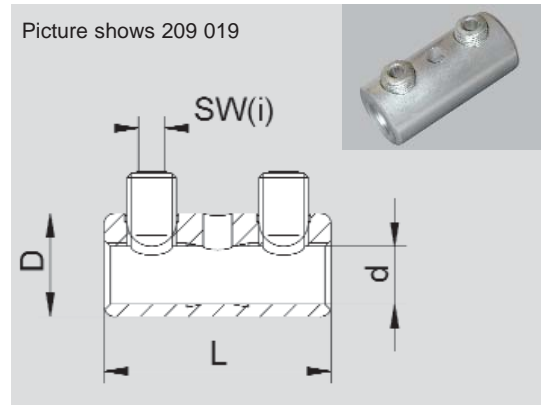
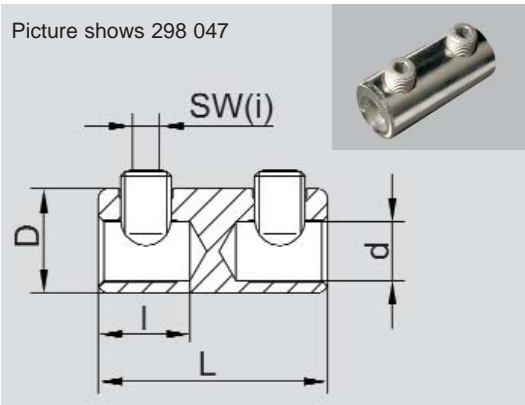

Cross Section [mm ²]	Connector Barrel							Contact Screw					Type Number		
	straight-through	with oil-stop	uncoated	tin-plated	Dimensions [mm]				socket screw	shear-head screw removable	shear-head screw unremovable	number		SW(i) (DIN 475)	torque [Nm]
					D	d	L	l							
16-50 RE 16-95 RM 50-95 SE 35-70 SM / 95 SM(r)	•		•		25	14.4	55		•			2	5	20	209 019
	•		•		25	14.4	55			•		2	5	20	209 081
	•		•		25	14.4	55				•	2	5	20	298 188
	•			•	25	14.4	55		•			2	5	20	298 061
	•			•	25	14.4	55			•		2	5	20	209 087
		•	•		25	14.4	55	22	•			2	5	20	209 011
		•	•		25	14.4	55	22		•		2	5	20	209 080
		•		•	25	14.4	55	22	•			2	5	20	298 047
		•		•	25	14.4	55	22		•		2	5	20	209 089
		•		•	25	14.4	55	22			•	2	5	20	298 200
	•		•		25	14.4	92		•			4	5	20	209 052
	•			•	25	14.4	92		•			4	5	20	298 223
	•		•		25	14.4	92			•		4	5	20	209 075
	•			•	25	14.4	92			•		4	5	20	298 224
25-150 RE 25-150 RM 50-120 SE / 150 SE (90°)	•		•		28	16.9	70		•			2	6	25	209 116
	•		•		28	16.9	70				•	2	6	25	209 126
	•			•	28	16.9	70		•			2	6	25	298 324
	•			•	28	16.9	70				•	2	6	25	298 325
		•	•		28	16.9	70	31	•			2	6	25	298 213
		•	•		28	16.9	70	31			•	2	6	25	298 269
		•		•	28	16.9	70	31	•			2	6	25	298 245
		•		•	28	16.9	70	31			•	2	6	25	298 262
35-120 / 150 SE (90°)		•		•	28	16.9	70	31			•	2	6	25	298 364

Explanation of cross sections: R=round, S=sectorial, E=solid, M=stranded, (r)=rounded, (90°)=4-core cable
 Explanation of key sizes of contact screws: SW(i)=inner hexagon

Aluminium Screw Connector (continued)

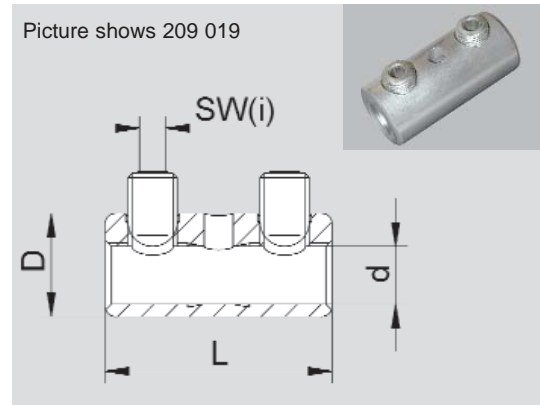
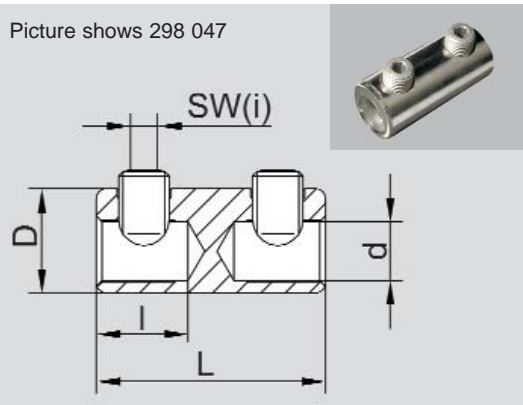

Cross Section [mm ²]	Connector Barrel							Contact Screw					Type Number		
	straight-through	with oil-stop	uncoated	tin-plated	Dimensions [mm]				socket screw	shear-head screw removable	shear-head screw unremovable	number		SW(i) (DIN 475)	torque [Nm]
					D	d	L	l							
35-50 RE	•		•		32	19.6	80		•			2	6	25	209 020
35-185 RM	•		•		32	19.6	80			•		2	6	25	209 082
50-150 SE / 185 SE (90°)	•		•		32	19.6	80			•		2	6	25	298 189
35-150 SM / 185 SM(r)	•			•	32	19.6	80		•			2	6	25	298 062
	•			•	32	19.6	80			•		2	6	25	209 088
	•			•	32	19.6	80			•		2	6	25	298 255
		•	•		32	19.6	80	32.5	•			2	6	25	209 012
		•	•		32	19.6	80	32.5		•		2	6	25	209 072
		•		•	32	19.6	80	32.5	•			2	6	25	298 088
		•		•	32	19.6	80	32.5		•		2	6	25	209 090
		•		•	32	19.6	80	32.5			•	2	6	25	298 172
	•		•		32	19.6	108		•			4	6	25	209 050
	•		•		32	19.6	108			•		4	6	25	209 065
	•			•	32	19.6	108		•			4	6	25	298 225
	•			•	32	19.6	108			•		4	6	25	298 226
50-150 RE 50-185 RM 50-150 SE / 185 SE (90°) 50-150 SM / 185 SM(r)	•		•		32	19.6	108			•		4	6	25	298 121
70-150 RM 70-150 SE		•	•		32	19.6	80	32.5			•	2	6	25	298 141
120-150 RE	•		•		38	25	128			•		4	6	25	298 174
120-240 RM	•			•	38	25	128			•		4	6	25	298 244
120-240 SE		•		•	38	25	128	58.5		•		4	6	25	298 256
120-240 SM		•		•	38	25	128	58.5		•		4	6	25	298 256
150-240 M	•		•		38	25	128		•			4	6	25	298 257

Explanation of cross sections: R=round, S=sectorial, E=solid, M=stranded, (r)=rounded, (90°)=4-core cable
 Explanation of key sizes of contact screws: SW(i)=inner hexagon

Aluminium Screw Connector with Tap-Off

Low Voltage

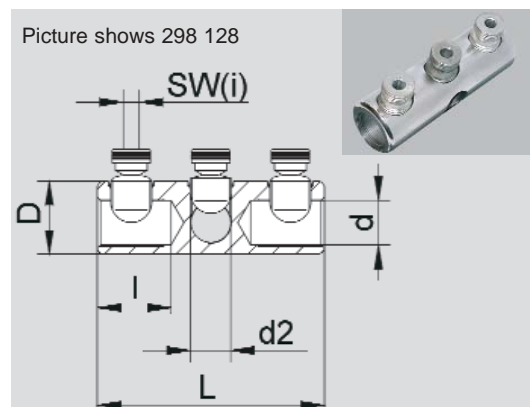
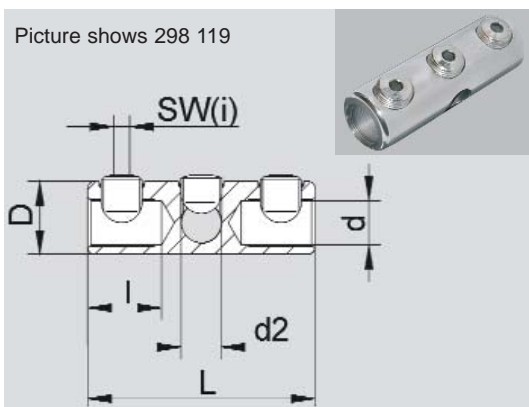

Cross Section [mm ²]		Connector Barrel					Contact Screw					Type Number				
Mains	Branch	with oil-stop	uncoated	tin-plated	Dimensions [mm]					socket screw	shear-head screw removable	number mains	number branch	SW(i) (DIN 475)	torque [Nm]	
					D	d	d2	L	I							
Al 35 RE Cu 35 RM	Cu 10 RE	•		•	20	9.4	9.4	55	18	•		2	1	4	15	298 260
35-50 RE 35-185 RM 50-150 SE 185 SE (90°) 35-150 SM 185 SM(r)	6-50 SE	•	•		32	19.6	10	80	29.5	•		2	1	(1)	(1)	298 040
35-50 RE 35-185 RM 50-150 SE 185 SE (90°) 35-150 SM 185 SM(r)	35-150 RE	•	•		32	19.6	17.5	100	32.5	•		2	1	6	25	298 119
	35-150 RM	•	•		32	19.6	17.5	100	32.5		•	2	1	6	25	298 128
	50-120 SE	•		•	32	19.6	17.5	100	32.5		•	2	1	6	25	298 181
	150 SE (90°)	•	•		32	19.6	17.5	140	32.5	•		2	1	6	25	298 162
	35-120 SM	•	•		32	19.6	17.5	140	32.5		•	2	1	6	25	298 155
120-240 M	6-95 RM 2x 25 RM 150 SE	•	•		38	25	17.5	150	56		•	4	1	6	25	298 161
150-240 M	2x 25 RM 150 SE	•	•		38	23	17.5	150	56	•		4	1	6	25	298 157

Explanation of cross sections: R=round, S=sectorial, E=solid, M=stranded, (r)=rounded, (90°)=4-core cable

Explanation of key sizes of contact screws: SW(i)=inner hexagon

(1) Contact screw of main conductor: SW6 / 25 Nm

Contact screw of branch conductor: SW5 / 20 Nm

Aluminium Screw Connector with Insulated Barrel

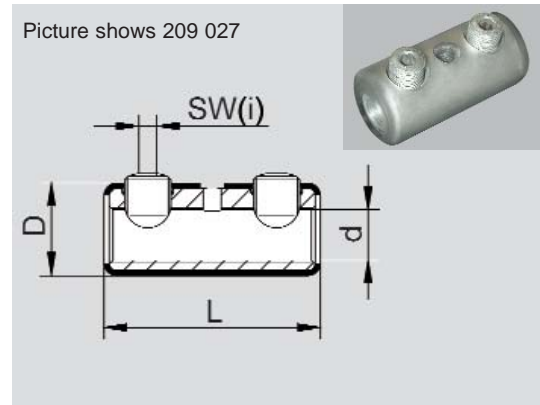
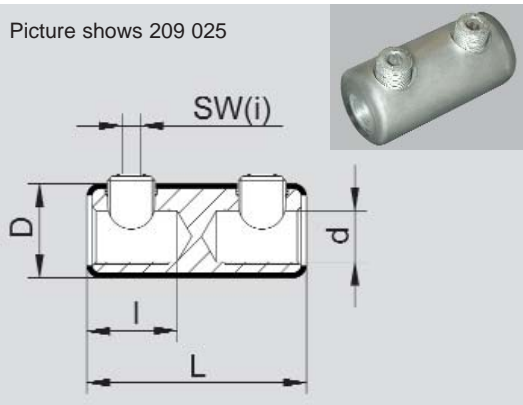

Cross Section [mm ²]	Connector Barrel								Contact Screw					Type Number	
	straight-through	with oil-stop	uncoated	tin-plated	Dimensions [mm]				socket screw	shear-head screw removable	shear-head screw unremovable	number	SW(i) (DIN 475)		torque [Nm]
					D	d	L	l							
6-35 RE 6-25 RM	•		•		14	7.2	60		•			2	4	8	298 097
6-35 RM 6-35 SM		•		•	18	9.4	42				•	2	4	8	298 305
10-70 RE 10-70 RM 50-70 SE 35-70 SM	•			•	25	12.5	87		•			2	5	15	298 095
16-50 RE 16-95 RM 50-70 SE / 95 SE (90°) 35-70 SM / 95 SM(r)	•		•		28.2	14.4	58.2		•			2	5	20	209 027
	•		•		28.2	14.4	58.2			•		2	5	20	209 085
	•			•	28.2	14.4	58.2		•			2	5	20	298 063
		•	•		28.2	14.4	58.2	23.6	•			2	5	20	209 025
		•	•		28.2	14.4	58.2	23.6		•		2	5	20	209 083
25-150 SE / 185 SE (90°) / 150 SM		•	•		36	19.6	84	34.5			•	2	6	25	298 142
35-50 RE 35-185 RM 50-150 SE / 185 SE (90°) 35-150 SM / 185 SM(r)	•		•		36	19.6	84		•			2	6	25	209 028
	•		•		36	19.6	84			•		2	6	25	209 086
	•			•	36	19.6	84		•			2	6	25	298 064
		•	•		36	19.6	84	34.5	•			2	6	25	209 026
		•	•		36	19.6	84	34.5		•		2	6	25	209 084

Explanation of cross sections: R=round, S=sectorial, E=solid, M=stranded, (r)=rounded, (90°)=4-core cable
 Explanation of key sizes of contact screws: SW(i)=inner hexagon

Aluminium Screw Connector for Insulated Cable Conductors

Picture shows 209 122

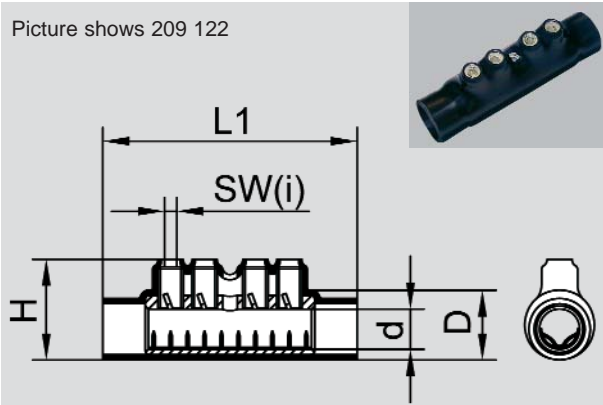

Cross Section [mm ²]	Connector Barrel				Contact Screw				Type Number				
	straight-through	with oil-stop	uncoated	tin-plated	Dimensions [mm]								
					D	d	L1	H		insulation-piercing screw	number	SW(i) (DIN 475)	torque [Nm]
50-95 Al SE 25-70 Cu SM	•		•		32	19	120	47	•	4	5	20	209 122
50-120 Al SE 70-95 Cu SM	•		•		35	22	120	50	•	4	5	20	209 123
95-185 Al SE 95-150 Cu SM	•		•		41	26	120	55	•	4	5	20	209 124

Explanation of cross sections: S=sectorial, E=solid, M=stranded
Explanation of key sizes of contact screws: SW(i)=inner hexagon

These fully-insulated screw connectors are supplied with pre-shrunk insulation. This cover is bridging proof and safe from manual contact. It is provided with openings only to fit the conductors and the installation tool.

Conductor ends are fit into the screw connector with their insulation.

When screws are tightened the insulation-piercing screws and their ring-shaped counter-contacts will cut through the conductor insulation.

Aluminium Screw Connector with Sector-Shaped Clamping Channel

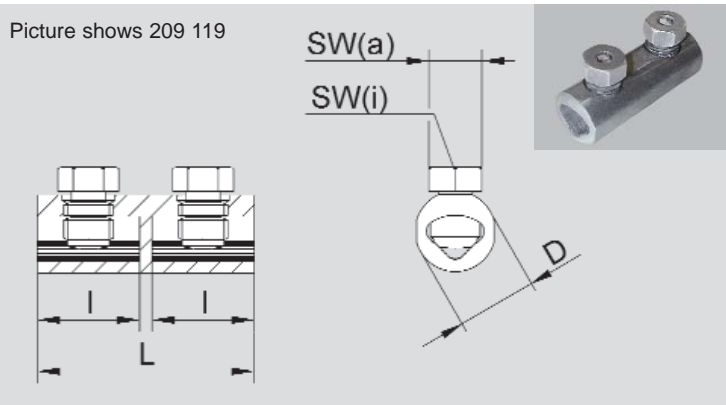

Cross Section [mm ²]	Connector Barrel					Contact Screw							Type Number			
	straight-through	with oil-stop	uncoated	tin-plated	greased	Dimensions [mm]			socket screw	shear-head screw removable	shear-head screw unremovable	number		SW(a) (DIN 475)	SW(i) (DIN 475)	torque [Nm]
						D	L	I								
25-120 RE 25-70 RM / 95 RM(v) 50-150 SE 35-120 SM		•	•		•	26	70	33			•	2	17	6	24 ⁽¹⁾	209 119
		•		•		26	70	33			•	2	17	6	-	298 261
	•					26	70	33			•	2	17	6	25	298 356

Explanation of cross sections: R=round, S=sectorial, E=solid, M=stranded, (v)=compacted
 Explanation of key sizes of contact screws: SW(a)=outer hexagon, SW(i)=inner hexagon
 (1) Depending on size of cross section

These screw connectors are featured with a reduced outer diameter and a sector-shaped clamping channel. This special shape of the clamping channel supports an optimal position of the conductor underneath the contact screw.

The contact screw is designed as a double shear-head bolt with inner and outer hexagon. Both hexagons may be used alternatively during installation so that the electrician can choose his preferred installation tool.

The nominal break points of the contact screw are dimensioned to reach a sufficient contact force for each conductor without using extreme compression and therefore causing mechanical damage to the conductor. Very slight protrusion of screws after contact enables an easy installation of shrink-sleeves.

Copper Screw Connector

Picture shows 198 381

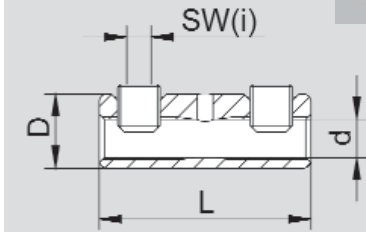

Low Voltage

Cross Section [mm ²]	Connector Barrel								Contact Screw					Type Number	
	straight-through	with oil-stop	uncoated	tin-plated	Dimensions [mm]				socket screw	shear-head screw removable	shear-head screw unremovable	number	SW(i) (DIN 475)		torque [Nm]
					D	d	L	l							
1.5-6 RE	•			•	7	3.5	25		•			2	2	4	198 413
1.5-16 RE / 16 RM	•		•		10	5.5	30		•			2	2.5	4	198 394
	•			•	10	5.5	30		•			2	2.5	4	198 392
6-25 RM / 35 RE	•			•	14	7.2	40		•			2	4	10	198 381

Explanation of cross sections: R=round, E=solid, M=stranded
 Explanation of key sizes of contact screws: SW(i)=inner hexagon

Aluminium Screw Cable Lugs

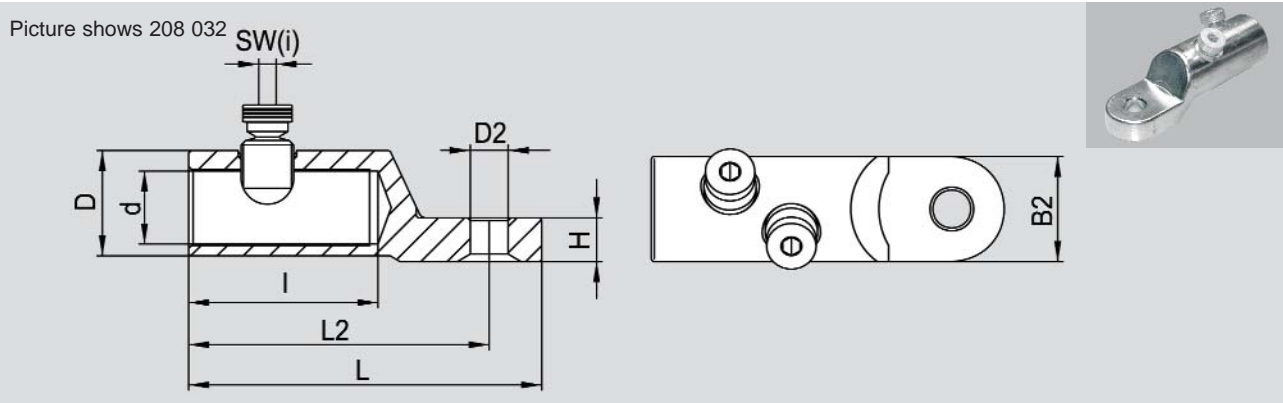

Cross Section [mm ²]	Connector Barrel									Contact Screw				Type Number	
	tin-plated	Dimensions [mm]								shear-head screw unremovable	shear-head screw removable	number	SW(i) (DIN 475)		torque [Nm]
		W2	D	D2 ⁽¹⁾	d	H	L	L2	I						
16-95 RE 16-95 RM 50-70 SE / 95 SE 25-70 SM / 95 SM(r)	•	23	23	13	14	8	78	66	45	•		2	5	20	298 139
35-150 RE 35-150 RM 50-120 SE 35-120 SM(r)	•	28	28	11	17.5	10	92	78	50		•	2	6	25	208 034
	•	28	28	13	17.5	10	92	78	50	•		2	6	25	298 140
	•	28	28	13	17.5	10	92	78	50		•	2	6	25	208 033
120-150 RE 120-240 RM 120-185 SE 120-185 SM / 240 SM (90°)	•	36	36	13	25	15	121	103	65		•	2	6	25	208 032

Explanation of cross sections: R=round, S=sectorial, E=solid, M=stranded, (r)=rounded, (90°)=4-core cable

Explanation of key sizes of contact screws: SW(i)=inner hexagon

1) Also available with other palm hole size, if required

Copper Screw Cable Lugs for Screen Wires and Wavecon-cable

Low Voltage

Picture shows 198 273

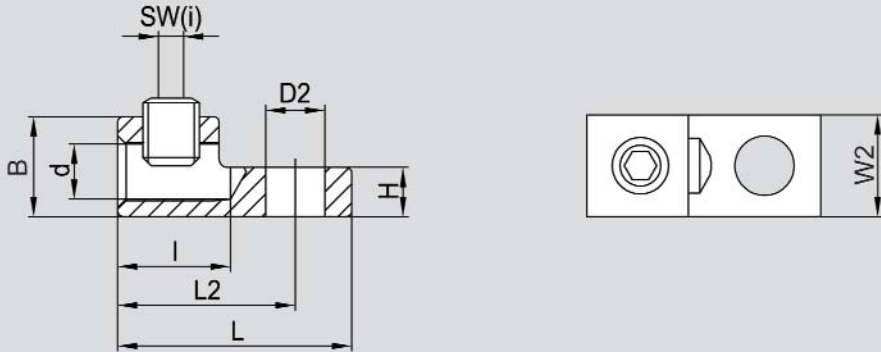

Cross Section [mm ²]	Connector Barrel									Contact Screw				Type Number	
	tin-plated	Dimensions [mm]								socket screw	shear-head screw unremovable	number	SW(i) (DIN 475)		torque [Nm]
B		W2	D2 ⁽¹⁾	d	H	L	L2	I							
6-50 RM	•	17.7	18	10.5	9.9	8.7	41.5	31.5	20	•		1	5	-	198 273
10-70 Cu 13x Al-flat 5.2x1	•	16	16	10.5	10.5	3.5	51	40.5	20		•	1	5	15	198 399
	•	16	16	12.5	10.5	3.5	51	40.5	20		•	1	5	15	198 423

Picture shows 108 017

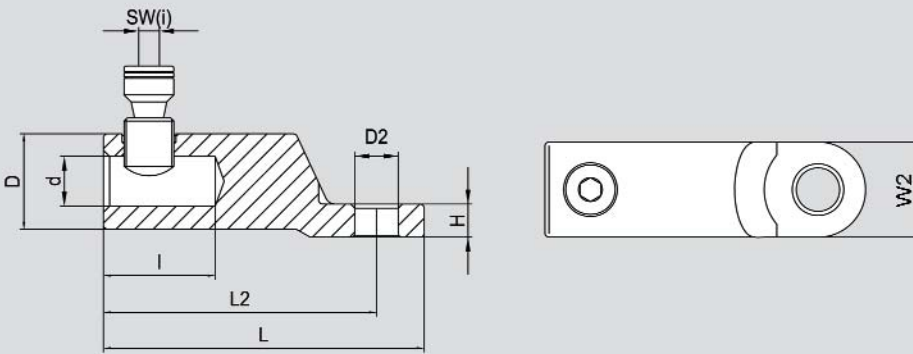

Cross Section [mm ²]	Connector Barrel									Contact Screw				Type Number	
	tin-plated	Dimensions [mm]								socket screw	shear-head screw unremovable	number	SW(i) (DIN 475)		torque [Nm]
W2		D	D2 ⁽¹⁾	d	H	L	L2	I							
Ø12 16-70 RM	•	23	23	10.5	12	8	78	66	27		•	1	5	20	108 017
	•	23	23	13	12	8	78	66	27	•		1	5	20	198 417
	•	23	23	13	12	8	78	66	27		•	1	5	20	108 016

Explanation of cross sections: R=round, M=stranded
 Explanation of key sizes of contact screws: SW(i)=inner hexagon
 1) Also available with other palm hole size, if required

Aluminium Screw Connector, Excentric Design

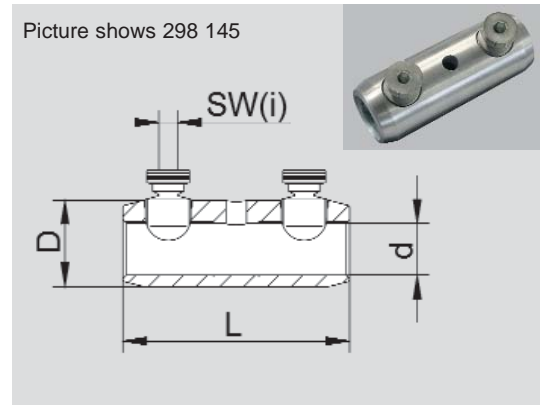
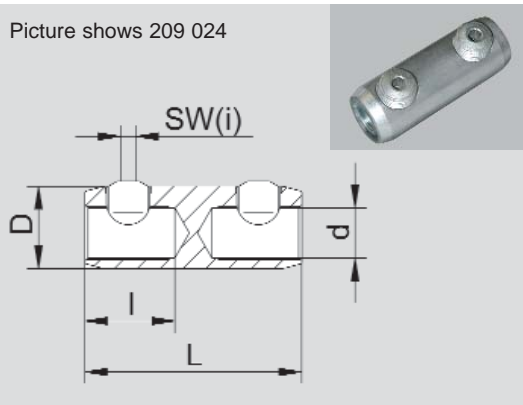

Cross Section [mm ²]	Connector Barrel							Contact Screw					Type Number		
	straight-through	with oil-stop	uncoated	tin-plated	Dimensions [mm]				socket screw	shear-head screw removable	shear-head screw unremovable	number		SW(i) (DIN 475)	torque [Nm]
					D	d	L	I							
50-150 RM 35-120 SM / 150 SM(r)		•	•		30	17.5	80	34	•			2	6	25	209 024
		•	•		30	17.5	80	34		•		2	6	25	209 079
		•	•		30	17.5	80	34			•	2	6	25	209 095
		•		•	30	17.5	80	34	•			2	6	25	298 227
		•		•	30	17.5	80	34		•		2	6	25	298 228
25-150 RE 25-150 RM 50-150 SE 35-120 SM / 150 SM (90°)		•	•		32	19.6	108	48	•			4	6	25	298 143
35-150 RE 35-150 RM 50-150 SE 35-150 SM		•	•		32	19.6	108	48	•			4	6	25	298 101
		•	•		32	19.6	108	48		•		4	6	25	298 109
		•		•	32	19.6	108	48	•			4	6	25	298 229
35-185 RE 35-185 RM 50-150 SE 35-120 SM / 150 SM(r)		•		•	32	19.6	108	48		•		4	6	25	298 186
150 RE 185 RM 150 SE 95-150 SM / 185 SM(r)		•	•		32	19.6	108	48			•	4	6	25	298 135
150-240 RM / 240 SM(r)	•		•		38	23.3	100			•		2	6	25	298 145
		•	•		38	23.3	100	41.5	•			2	6	25	209 018
		•	•		38	23.3	100	41.5		•		2	6	25	209 078
		•		•	38	23.3	100	41.5	•			2	6	25	298 231
		•		•	38	23.3	100	41.5		•		2	6	25	298 187

Explanation of cross sections: R=round, S=sectorial, E=solid, M=stranded, (r)=rounded, (90°)=4-core cable
 Explanation of key sizes of contact screws: SW(i)=inner hexagon

Aluminium Screw Connector, Excentric Design (continued)

Picture shows 298 096

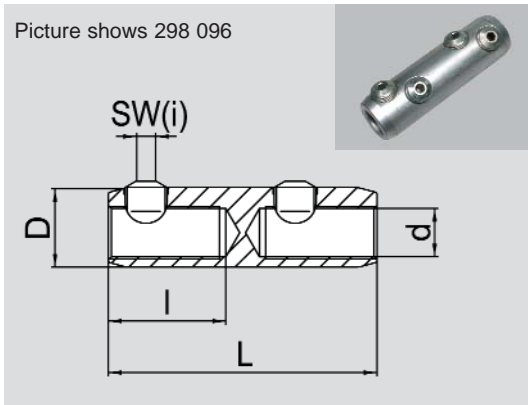

Cross Section [mm ²]	Connector Barrel							Contact Screw					Type Number		
	straight-through	with oil-stop	uncoated	tin-plated	Dimensions [mm]				socket screw	shear-head screw removable	shear-head screw unremovable	number		SW(l) (DIN 475)	torque [Nm]
					D	d	L	I							
150-240 RM / 240 SM(r)	•	•	•		38	23.3	128	56	•			4	6	25	298 096 ⁽¹⁾
		•	•		38	23.3	128	56	•			4	6	25	298 102
		•	•		38	23.3	128	56		•		4	6	25	209 067 ⁽¹⁾
		•	•		38	23.3	128	56			•	4	6	25	298 132
		•		•	38	23.3	128	56	•			4	6	25	298 230 ⁽¹⁾
		•		•	38	23.3	128	56		•		4	6	25	298 167 ⁽¹⁾

Explanation of cross sections: R=round, S=sectorial, M=stranded, (r)=rounded

Explanation of key sizes of contact screws: SW(i)=inner hexagon

(1) Option to increase cross sectional range by 50-120 mm² with contact screws available on request

Aluminium Screw Connector, Excentric Design (continued)

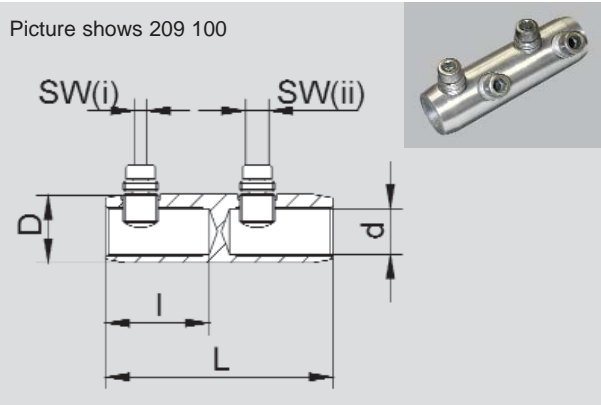

Cross Section [mm ²]	Connector Barrel				Contact Screw								Type Number		
	straight-through	with oil-stop	uncoated	tin-plated	Dimensions [mm]				socket screw	shear-head screw removable	shear-head screw unremovable	number		SW(i) (ii) (DIN 475)	torque [Nm]
					D	d	L	I							
35-120 RE 35-120 RM 50-120 SE 35-120 SM		•	•		35	23	117	53		• ⁽¹⁾		4	8 20	209 100	
150 RE 150-240 RM 150-185 SE / 240 SE (90°) 150 SM / 185 SM (90°)												6 25			
35-120 RE 35-120 RM 50-120 SE 35-120 SM		•		•	35	23	117	53		• ⁽¹⁾		4	8 20	298 321	
150 RE 150-240 RM 150-185 SE / 240 SE (90°) 150 SM / 185 SM (90°)												6 25			

Explanation of cross sections: R=round, S=sectorial, E=solid, M=stranded, (90°)=4-core cable

Explanation of key sizes of contact screws: SW(i)=inner hexagon

(1) Removable shear-head bolt only for cross sections 35-120 mm²

This screw connector was designed to cover a large cross sectional range.

Shear heads are provided with two different key sizes SW 6 and SW 8. For cross sections 35-120 mm² key size SW 8 is active with a torque of 20 Nm and for cross sections 150-240 mm² key size SW 6 with a torque of 25 Nm.

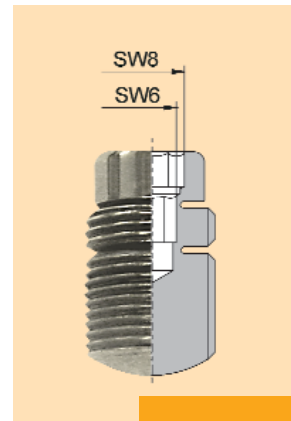

Aluminium Screw Connector, Excentric Design (Reduction Connector)

Picture shows 298 098

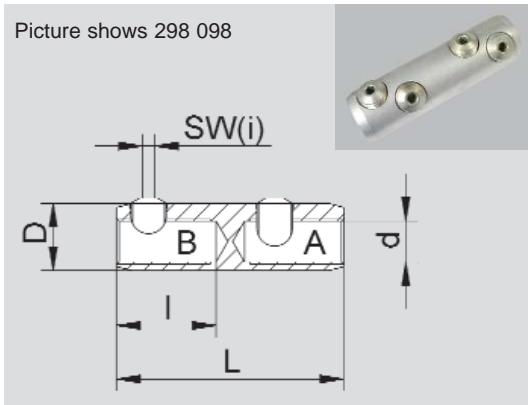

Cross Section [mm ²]		Connector Barrel				Contact Screw						Type Number				
A	B	straight-through	with oil-stop	uncoated	tin-plated	Dimensions [mm]				socket screw	shear-head screw removable	shear-head screw unremovable	number	SW(i) (DIN 475)	torque [Nm]	
						D	d	L	I							
35 RM-70 SM	150 RE / 150 SE 185 RM 95-150 SM 185 SM(r)		•	•		32	19.6	108	48			•	4	6	25	298 136
50-120 RM	150 RE-185 SM 185 SE(r)		•	•		32	19.6	108	48			•	4	6	25	298 131
95-120	150-240 RM(v)		•	•		33	21	108	48			•	4	6	25	298 144
50-120 RM 120 SM	150-240 RM 240 SM(r)		•	•		38	23.3	128	56	•			4	6	25	298 098
			•	•		38	23.3	128	56		•		4	6	25	209 069
			•		•	38	23.3	128	56		•		4	6	25	209 127

Explanation of cross sections: R=round, S=sectorial, E=solid, M=stranded, (v)=compacted, (r)=rounded
 Explanation of key sizes of contact screws: SW(i)=inner hexagon

Medium Voltage

Aluminium Screw Connector, Concentric Design (Reduction Connector)

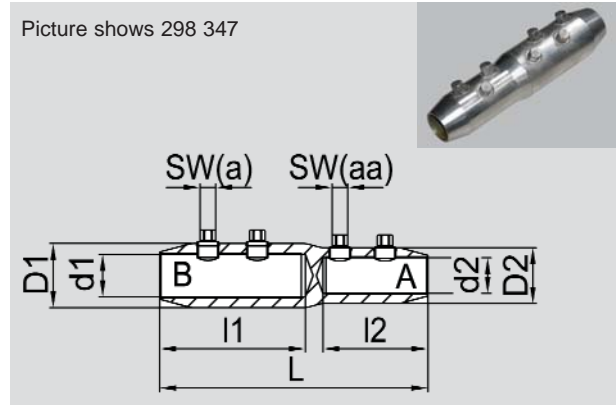
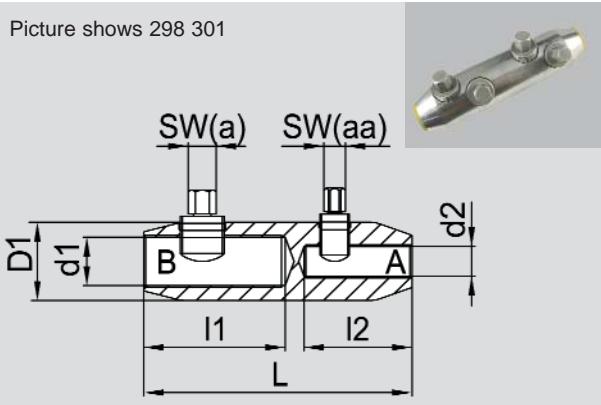

Cross Section [mm ²]		Connector Barrel										Contact Screw			Type Number	
A	B	filled with grease	with oil-stop	uncoated	Dimensions [mm]							shear-head screw unremovable	number	SW(a) (aa) (DIN 475)	torque [Nm]	
					D1	D2	d1	d2	L	l1	l2					
25-95 RE 25-70 RM / 95 RM(v) 50-70 SE / 95 SE(r) 35-50 SM / 70 SM(*)	70-240 RE 70-185 RM / 240 RM(v) 70-185 SE(*) 70-150 SM / 185 SM(r)	•	•	•	33		20.4	12.4	110	58	44	•	2	8	16 ⁽¹⁾ - 19	298 301
												•	2	10	27 ⁽¹⁾ - 31	
95-400 RE 95-400 RM / 400 RM(v) 95-240 SE 95-300 SM(r)	300-630 RM 300-630 RM(v) 300-400 SM(*)	•	•	•	52		33.4	27.4	185	93	79	•	3	10	27 ⁽¹⁾ - 31	298 368
												•	3	13	28 ⁽¹⁾ - 32	
630 RM(v)	800 / 1000 AI RM(v)	•	•	•	60	52	39.4	33.4	250	135	98	•	4	13	28 ⁽¹⁾ - 29.5	298 347
												•	3	13	28	

Explanation of cross sections: R=round, S=sectorial, E=solid, M=stranded, (v)=compacted, (r)=rounded,

(*)=conductor slightly rounded, for instance with flat-nose pliers

Explanation of key sizes of contact screws: SW(a)=outer hexagon, SW(i)=inner hexagon

(1) Depending on size of cross section

Aluminium Screw Connector with Intelligent Contact Screw, Concentric Design

Picture shows 209 110

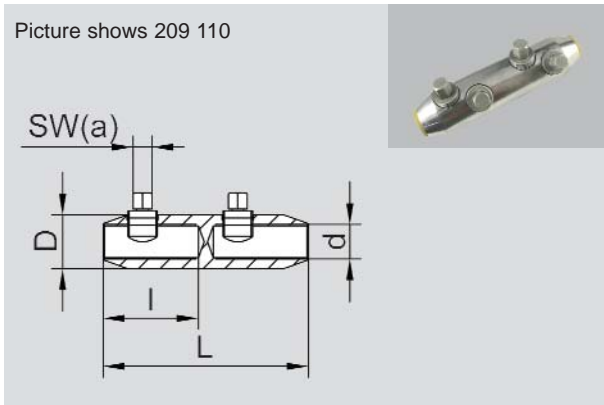

Size	Cross Section [mm²]	Connector Barrel				Contact Screw				Type Number			
		with oil-stop	filled with grease	tin-plated	Dimensions [mm]				shear-head screw unremovable		number	SW(a) (DIN 475)	torque [Nm]
D	d				L	l							
1	25-95 RE 25-70 RM / 95 RM(v) 50-70 SE / 95 SE(r) 35-50 SM / 70 SM(*)	•	•	•	23	12.4	95	44	•	4	8	16 ⁽¹⁾ - 19	209 109
2	50-150 RE 50-120 RM / 150 RM(v) 50-120 SE / 150 SE(r) 50-95 SM / 120 SM(r)	•	•	•	28	15.4	110	51	•	4	8	19 ⁽¹⁾ - 22	209 112
3	70-240 RE 70-185 RM / 240 RM(v) 70-150 SE / 185 SE(*) 70-150 SM / 185 SM(r)	•	•	•	33	20.4	125	58	•	4	10	27 ⁽¹⁾ - 31	209 110
(2)	70-240 RE 70-240 RM / 240 RM(v) 70-240 SE(*) 70-240 SM(*)	•	•	•	34	22.4	120	55.5	•	4	10	27 ⁽¹⁾ - 31	209 129
4	120-300 RE 120-300 RM / 300 RM(v) 120-240 SE 120-185 SM / 240 SM(r)	•	•	•	36	24.4	140	64.5	•	4	13	28 ⁽¹⁾ - 32	209 111
5	95-400 RE 95-400 RM / 400 RM(v) 95-240 SE 95-240 SM / 300 SM(r)	•	•	•	42	27.4	170	79	•	6	10	27 ⁽¹⁾ - 31	209 113
6	300-630 RE 300-630 RM 300-630 RM(v) 300-400 SM(*)	•	•	•	52	33.4	200	93	•	6	13	28 ⁽¹⁾ - 32	209 114
7	800-1000 RE 800-1000 RM(v)	•	•	•	60	40.4	230	104	•	8	13	28 ⁽¹⁾ - 32	209 115

Explanation of cross sections: R=round, S=sectorial, E=solid, M=stranded, (v)=compacted, (r)=rounded,

(*)=conductor slightly rounded, for instance with flat-nose pliers

Explanation of key sizes of contact screws: SW(a)=outer hexagon

(1) Depending on size of cross section

(2) Special design deducted from size 3

Aluminium Screw Connector for Screen Wires of Cables to VDE and TGL Standards

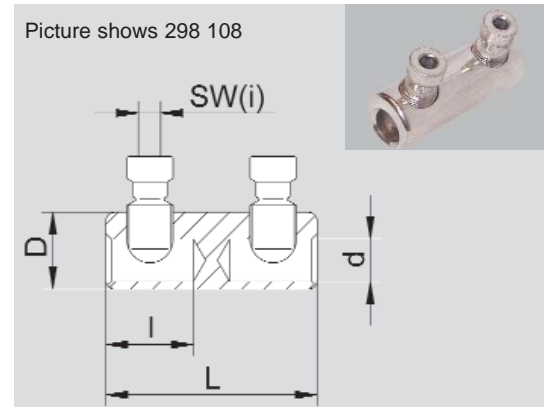
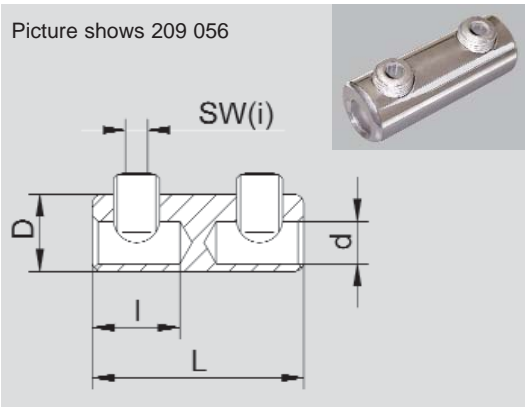

Cross Section [mm ²]	Connector Barrel							Contact Screw					Type Number		
	straight-through	with oil-stop	uncoated	tin-plated	Dimensions [mm]				socket screw	shear-head screw removable	shear-head screw unremovable	number		SW(i) (DIN 475)	torque [Nm]
					D	d	L	I							
16-50 Cu RM		•		•	20	11	55	22.8	•			2	5	10	209 056
3-13 each flat 1x 5.2 Al		•		•	20	11	55	22.8		•		2	5	10	298 108

Explanation of cross sections: R=round, M=stranded
 Explanation of key sizes of contact screws: SW(i)=inner hexagon

Copper Screw Connector for Copper Screen Wires

Picture shows 198 381

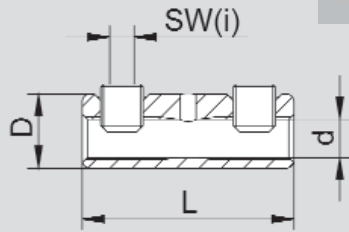

Picture shows 198 385

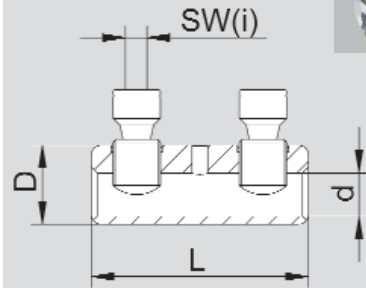

Cross Section [mm ²]	Connector Barrel							Contact Screw					Type Number		
	straight-through	with oil-stop	uncoated	tin-plated	Dimensions [mm]				socket screw	shear-head screw removable	shear-head screw unremovable	number		SW(i) (DIN 475)	torque [Nm]
					D	d	L	l							
6-35 RE / 25 RM	•			•	14	7.2	40		•			2	4	10	198 381
Ø11	•			•	20	11	55			•		2	5	15	198 385

Explanation of cross sections: R=round, E=solid, M=stranded
 Explanation of key sizes of contact screws: SW(i)=inner hexagon

Aluminium Screw Cable Lugs, Concentric Design

Picture shows 208 036

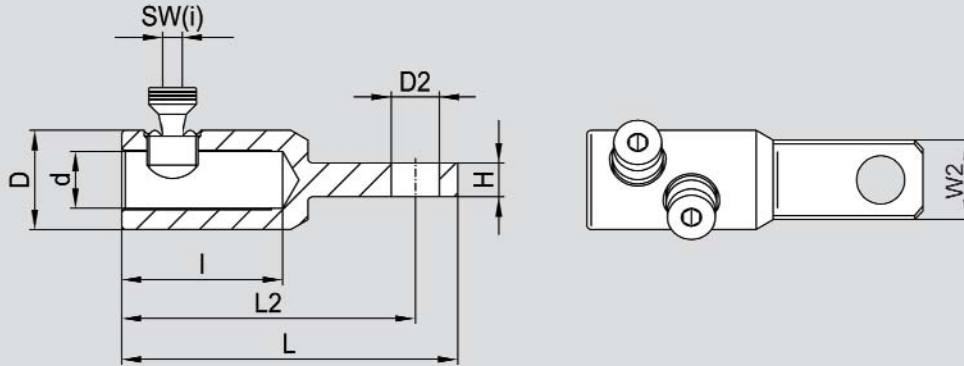

Cross Section [mm ²]	Connector Barrel									Contact Screw				Type Number	
	tin-plated	Dimensions [mm]								shear-head screw unremovable	shear-head screw removable	number	SW(i) (DIN 475)		torque [Nm]
W2		D	D2 ⁽¹⁾	d	H	L	L2	I							
120-240 Al 120-185 Cu	•	28	35	17	20	12	119	104	57	•		2	6	25	208 036

Explanation of key sizes of contact screws: SW(i)=inner hexagon
1) Also available with other palm hole size, if required

Aluminium Screw Cable Lugs with Intelligent Contact Screw, Concentric Design

Picture shows 298 238

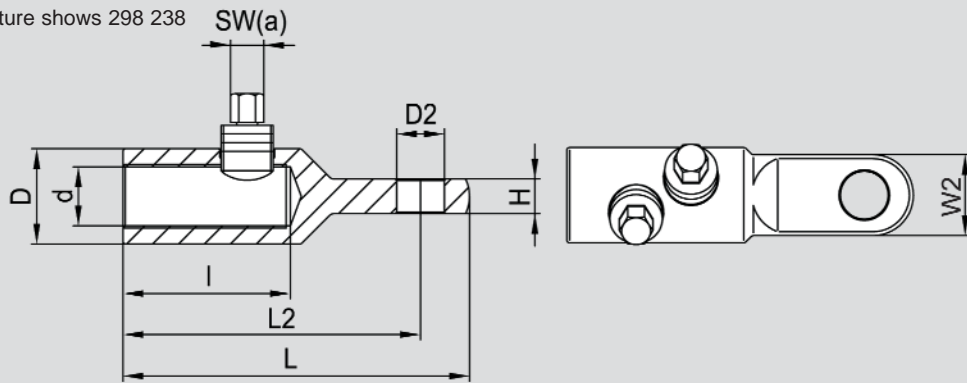

Size	Cross Section [mm ²]	Connector Barrel										Contact Screw			Type Number		
		filled with grease	tin-plated	Dimensions [mm]									shear-head screw unremovable	number		SW(a) (DIN 475)	torque [Nm]
				W2	D	D2 ⁽¹⁾	d	H	L	L2	I						
1	25-95 RM(v)	•	•	35	23	17.5	12.4	13	109.5	92	44	•	2	8	16 ⁽²⁾ - 19	298 373	
3	70-240 RE 70-185 RM / 240 RM(v) 70-150 SE / 185 SE(*) 70-150 SM / 185 SM(r)	•	•	28	33	16.5	20.4	12	120	103	58	•	2	10	27 ⁽²⁾ - 31	298 238	
3	70-240 RM(v)	•	•	35	33	17.5	20.4	13	123.5	106	58	•	2	10	27 ⁽²⁾ - 31	298 374	
5	95-400 RM(v)	•	•	35	38	17.5	25.4	13	145.5	128	80	•	3	10	27 ⁽²⁾ - 31	298 375	

Explanation of cross sections: R=round, S=sectorial, E=solid, M=stranded, (v)=compacted, (r)=rounded,

(*)=conductor slightly rounded, for instance with flat-nose pliers

Explanation of key sizes of contact screws: SW(a)=outer hexagon

(1) Also available with other palm hole size, if required

(2) Depending on size of cross section

Medium Voltage

Aluminium Screw Cable Lugs with Intelligent Contact Screw, Concentric Design

Picture shows 208 038

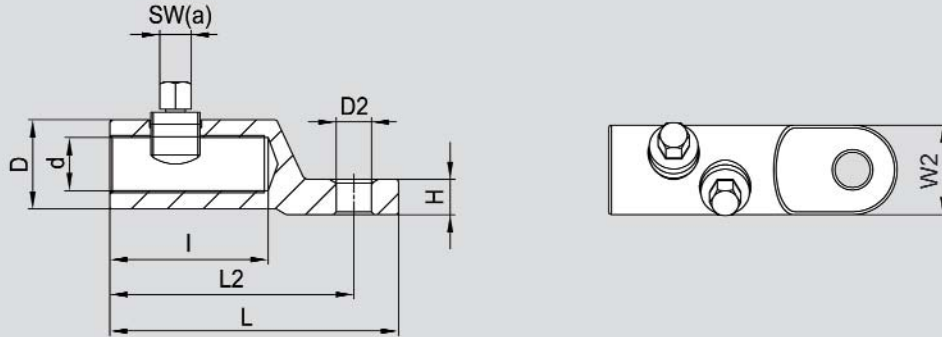

Size	Cross Section [mm ²]	Connector Barrel										Contact Screw			Type Number	
		filled with grease	tin-plated	Dimensions [mm]								shear-head screw unremovable	number	SW(a) (DIN 475)		torque [Nm]
				W2	D	D2 ⁽¹⁾	d	H	L	L2	I					
1	25-95 RE 25-70 RM / 95 RM(v) 50-70 SE / 95 SE(r) 35-50 SM / 70 SM(*)	•	•	23	23	9	12.4	8	77.5	66	44	•	2	8	16 ⁽²⁾ - 19	208 038
2	50-150 RE 50-120 RM / 150 RM(v) 50-120 SE / 150 SE(r) 50-95 SM / 120 SM(r)	•	•	28	28	11	15.4	10	92	78	51	•	2	8	19 ⁽²⁾ - 22	208 040
3	70-240 RE 70-185 RM / 240 RM(v) 70-150 SE / 185 SE(*) 70-150 SM / 185 SM(r)	•	•	33	33	13	20.4	13	106.5	90	58	•	2	10	27 ⁽²⁾ - 31	208 039
4	120-300 RE 120-300 RM / 300 RM(v) 120-240 SE 120-185 SM / 240 SM(r)	•	•	36	36	13	24.4	15	121	103	64.5	•	2	13	28 ⁽²⁾ - 32	208 041
5	95-400 RE 95-400 RM / 400 RM(v) 95-240 SE 95-240 SM / 300 SM(r)	•	•	42	42	17	27.4	16	136	115	79	•	3	10	27 ⁽²⁾ - 31	208 042
6	300-630 RE 300-630 RM 300-630 RM(v) 300-400 SM(*)	•	•	52	52	17	33.4	18	164	138	93	•	3	13	28 ⁽²⁾ - 32	208 043
7	800-1000 RE 800-1000 RM(v)	•	•	60	60	21	40.4	20	190	160	104	•	4	13	28 ⁽²⁾ - 32	208 044

Explanation of cross sections: R=round, S=sectorial, E=solid, M=stranded, (v)=compacted, (r)=rounded,

(*)=conductor slightly rounded, for instance with flat-nose pliers

Explanation of key sizes of contact screws: SW(a)=outer hexagon

(1) Also available with other palm hole size, if required

(2) Depending on size of cross section

Copper Screw Cable Lugs for Screen Wires and Wavecon-cable

Medium Voltage

Picture shows 198 273

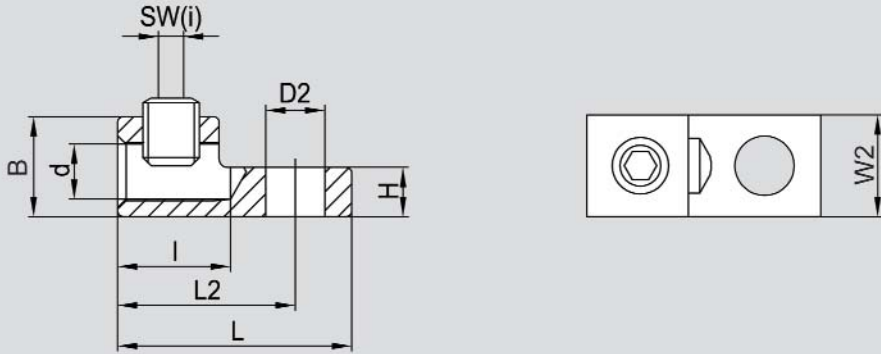

Cross Section [mm ²]	Connector Barrel									Contact Screw				Type Number	
	tin-plated	Dimensions [mm]								socket screw	shear-head screw unremovable	number	SW(i) (DIN 475)		torque [Nm]
B		W2	D2 ⁽¹⁾	d	H	L	L2	I							
6-50 RM	•	17.7	18	10.5	9.9	8.7	41.5	31.5	20	•		1	5	-	198 273
10-70 Cu	•	16	16	10.5	10.5	3.5	51	40.5	20		•	1	5	15	198 399
13x Al-flat 5.2x1	•	16	16	12.5	10.5	3.5	51	40.5	20		•	1	5	15	198 423

Picture shows 108 017

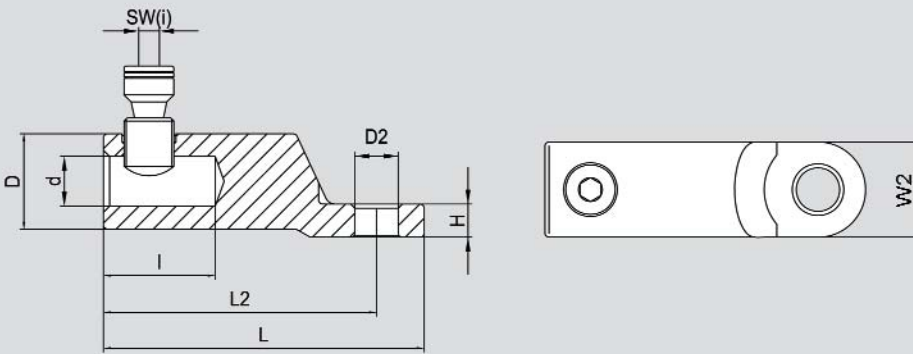

Cross Section [mm ²]	Connector Barrel									Contact Screw				Type Number	
	tin-plated	Dimensions [mm]								socket screw	shear-head screw unremovable	number	SW(i) (DIN 475)		torque [Nm]
W2		D	D2 ⁽¹⁾	d	H	L	L2	I							
Ø12	•	23	23	10.5	12	8	78	66	27		•	1	5	20	108 017
16-70 RM	•	23	23	13	12	8	78	66	27	•		1	5	20	198 417
	•	23	23	13	12	8	78	66	27		•	1	5	20	108 016

Explanation of cross sections: R=round, M=stranded
 Explanation of key sizes of contact screws: SW(i)=inner hexagon
 1) Also available with other palm hole size, if required



CUSTOMISED SOLUTIONS IN HIGH VOLTAGE CONTACT TECHNIQUE

Joining and connecting of high voltage cables by means of bolted contacts meanwhile is state of the art.

Longterm experience in welding and compressing is more and more replaced by mechanical connectors or mechanical top bolts.

Today, advantages of fast, simple, and safe installation by means of screw-type connections are also valued in high voltage applications.

A speciality in high voltage contact technique is the high voltage conductor itself, different from medium voltage or low voltage conductors in construction and cross section. Solid or stranded round conductors made of copper or aluminium are typical.

Especially the Milliken- or RMS-conductor is unusual, because its special sectorial construction requires a particular arrangement of contact bolts. The round conductor consists of several sectors insulated towards each other.

This construction reduces conduction losses which occur by the skin effect, specially so on large cross sections.

Also typical for high voltage are large cross sections. Although small cross sections such as 95 mm² are used as well, cross sections up to 3200 mm² prevail. With cross sections above 1200 mm², also Milliken-Conductors can be found.

Mechanical connectors and top bolts for high voltage are to be dimensioned precisely for its conductor and joint or termination.

Only this way it is possible to control electric fields of voltages above 70 kV, and to secure continuous prevention of joint destruction by partial discharge.

Screw Connectors, Mechanical Top Bolts and Bolted Contacts



For this reason, concentric design, prevention of edges caused by bolt protrusion, and an outer barrel diameter suitable for its cable joint or termination, are essential requirements on such contact elements. These features can only be provided by customised and individual design and production, mostly in small production lots.

ARCUS Schiffmann is able to design, produce, and supply on schedule such individual contact elements on short notice, customised to meet project requirements.

For this purpose we stock the raw material, and offer design know-how and ultra-modern CNC-production machines.

As such products are specifically manufactured for customers and projects, we do not detail them in our catalogue. Instead, these pages shall explain our expertise and ability to also support you in this field.

We look forward talking to you !

Stripping knife Type No. 612 012



Strips the outer conductive layer of medium voltage cable 10-30 kV, Ø18-54 mm, incl. knife plate 0.5 mm

Spare parts and accessories

Knife plate 0.25 mm	612 012 25
Knife plate 0.5 mm	612 012 17
Knife plate 0.6 mm	612 012 26
Knife plate 0.7 mm	612 012 18
Transport case	615 035

Cone cutter Type No. 612 003



Cuts a cone on conductor insulation of medium voltage cable with synthetic insulation 10-30 kV, 50-300 mm²

Spare parts and accessories

Spare blade	612 003 10
Knife sharpening stone	625 008



T-Box Wrench

Hexagon socket screw

SW 4

SW 5

SW 6

Type number

620 155

620 156

620 157



Angular Wrench

Hexagon socket screw

SW 5

SW 6

Type number

620 159

620 160



T-Handle Socket Wrench

KS 10, 200 mm long

KS 11, 200 mm long

KS 12, 200 mm long

KS 13, 200 mm long

KS 14, 200 mm long

KS 17, 200 mm long

KS 19, 300 mm long

KS 20, 300 mm long

KS 22, 300 mm long

KS 24, 300 mm long

KS 27, 300 mm long

KS 28, 300 mm long

KS 30, 300 mm long

KS 32, 300 mm long

Type number

620 031

620 032

620 033

620 034

620 035

620 036

620 037

620 038

620 039

620 040

620 041

620 042

620 043

620 044



Ratchet Wrench

(with insert KS 5)

Type number

620 090

Insert

for ratchet wrench

insert KS 5

insert KS 6

Type number

620 137 05

620 137 06



Spreading Wedge

length: 120 mm

length: 198 mm

Type number

109 177

198 184

Torque Wrench (20 Nm) Type No. 620 147 (Inserts excluded)

Suitable for live installation up to 1000 V AC / 1500 V DC



Function

ARCUS torque wrench is released after clockwise rotation.

When torque is reached the release is audible and perceptible.

Testing

ARCUS torque wrenches are supplied with test certificate and its own serial number.

Precision

ARCUS torque wrenches are manufactured with release precision of ± 1 Nm.

Torque Wrench with Insert	a (mm)	b (mm)
	195	100

Synthetic insulation to VDE 0682 part 201

Quick-change inserts

SW (DIN 475)	Type No.
5	620 148
6	620 149

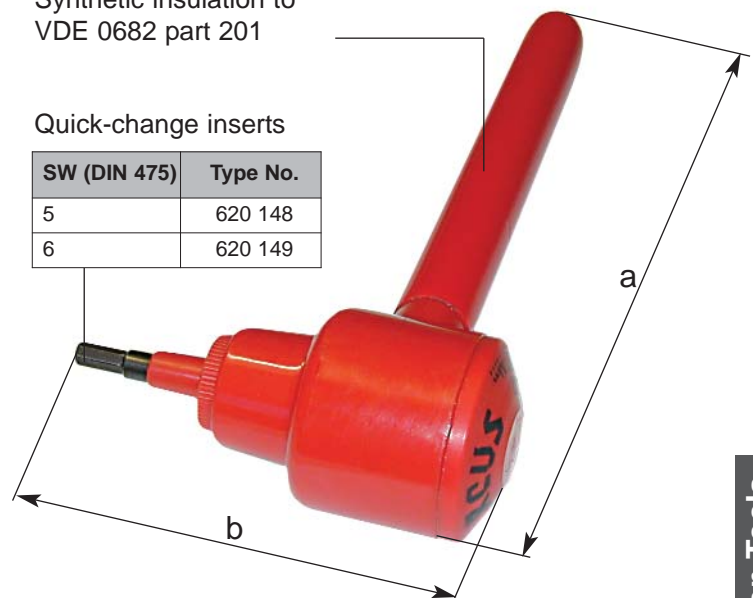

**Case made of synthetic material
Type No. 615 040**

With foamed inlay to take up one torque wrench and two inserts.

Explanation of key sizes of tools: SW=outer hexagon

Insulated Tools (continued)

Holding Tool for Screw Connectors with Outer Diameter 14 to 40 mm Type No. 622 009

- Suitable for live installation up to 1000 V AC / 1500 V DC
- For insulated and uninsulated mechanical connectors
- To IEC 60900 resp. EN 60900

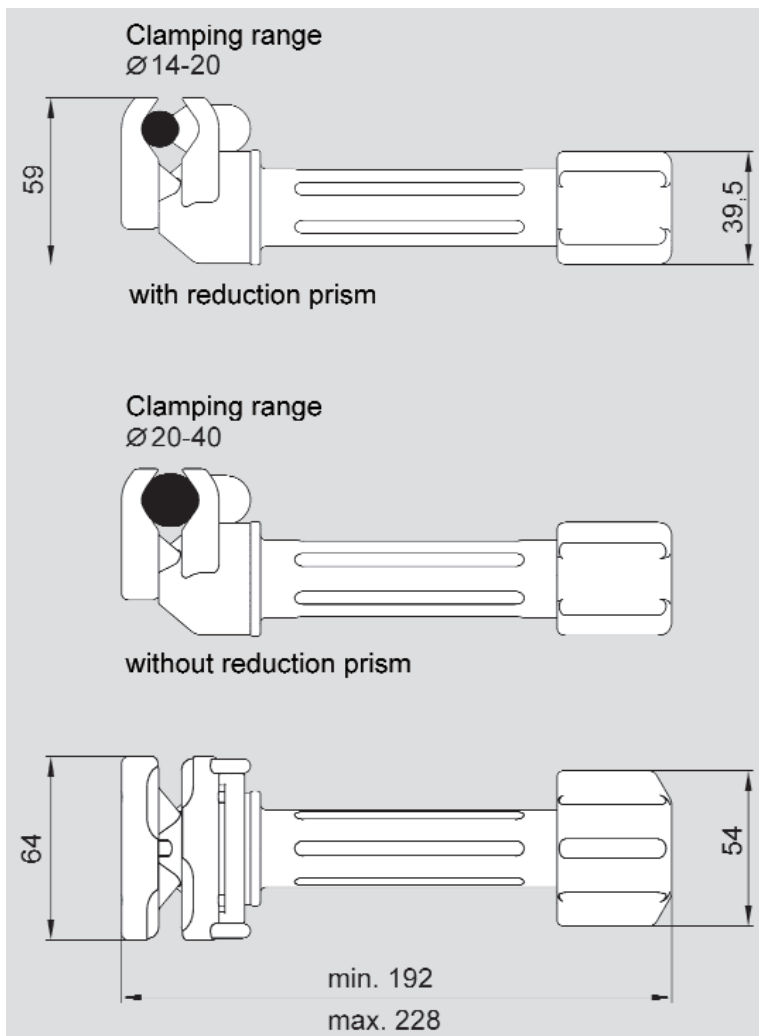

Application:	
No use of reduction prism	Ø20-40 mm
Use with reduction prism	Ø14-20 mm
Temperature limitation	-40 °C

Material:	
Handles and prism jaws	PA with glassfibre
Spindle	hardened steel
Mechanical parts	brass

Phone
General
+49 (0) 89 / 4 36 04 - 0

Fax
General
+49 (0) 89 4 31 68 88

Fax
Sales Department
+49 (0) 89 4 36 04 - 73

Internet
www.ARCUS-Schiffmann.com
info@ARCUS-Schiffmann.com

Seat of the Company
Truderinger Str. 199
D-81673 Munich