

'ACVOKE' CABLE SPIKER

STANDARD CABLE SPIKER

For use with steel wire armoured cable up to 4½ in. diameter.

HEAVY DUTY CABLE SPIKER

For use with steel wire armoured cable up to 6 in. diameter.

CABLE SPIKER CONVERSION KIT

For use with the standard cable Spiker ONLY when aluminium sheathed 11 kV cables are to be spiked.

ACCLES & SHELVOKE LIMITED.



WWW.CABLEJOINTS.CO.UK

THORNE & DERRICK UK

TEL 0044 191 490 1547 FAX 0044 477 5371

TEL 0044 117 977 4647 FAX 0044 977 5582

WWW.THORNEANDDERRICK.CO.UK

Contractors to Ministry of Defence,
Crown Agents for Overseas Governments and Administrations

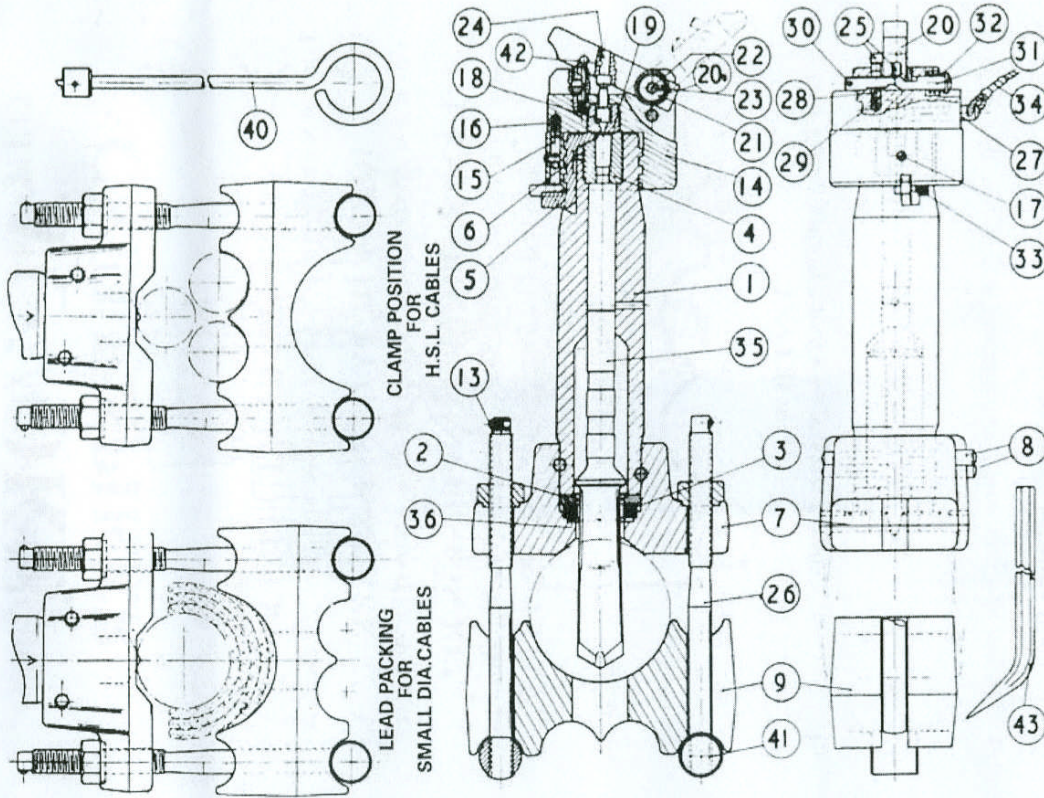

Part No.	DESCRIPTION	Off
1	Barrel	1
2	Barrel Base Steel Washer	1
3	Barrel Base Stop Washer	1
4	Breech Block	1
5	Extractor	1
6	Extractor Retaining Screw	1
7	Barrel Base	1
8	Barrel Base Taper Pin	2
9	Cable Clamp	1
14	Breech Cap	1
15	Breech Cap Latch	1
16	Breech Cap Latch Spring	1
17	Breech Cap Latch Retaining Screw	1
18	Firing Pin	1
19	Firing Pin Bush	1
20	Hammer and 20B Hammer Bush	1
21	Hammer Spring	1
22	Hammer Spring Pivot	1
24	Hammer Button	1
25	Stop Pin	2
26	Clamp Bolt Complete	2
27	Hammer Release Pin	1
28	Hammer Safety Cross Pin Spring	1
29	Hammer Safety Cross Pin Spring	1
30	Hammer Safety Cross Pin Dowel	1
31	Safety Catch	1
32	Safety Catch Spring	1
33	Breech Cap Stop Screw	1
34	Lanyard	1
35	Piston Punch	1
36	Piston Punch Locating Spring	1
40	Cleaner Complete	1
41	Trunnion	2
42	Hammer Button Cross Pin	1
43	Lever	1

**'ACVOKE'
CABLE SPIKER
STANDARD TYPE**



WWW.CABLEJOINTS.CO.UK
THORNE & DERRICK UK
 TEL 0044 191 490 1547 FAX 0044 477 5371
 TEL 0044 117 977 4647 FAX 0044 977 5582
 WWW.THORNEANDDERRICK.CO.UK

INSTRUCTIONS FOR USE (ALL CABLE SPIKERS)

1. Clamp tool securely to cable. Tighten clamp bolt nuts (26) evenly so that cable clamp (9, 46 or 9S depending on type) remains parallel to barrel base (7). Cable clamps are reversible to accommodate varying types of cable.
2. Press up breech cap latch (15), unscrew (right-hand thread) and remove breech cap (14).
3. Select correct strength of cartridge and insert in breech block (4) (see under cartridge selection page 7).
4. Screw breech cap (14) back into place seeing breech cap latch (15) trips past the extractor (5) and drops alongside stop screw (33).
5. Lay out lanyard (34) to its full length of 7 metres to give straight pull on hammer release pin (27). In confined spaces a crowbar or other 'corner' around which lanyard is pulled, may be desirable.
6. Pull back hammer (20), insert hammer release pin (27) sufficiently far to retain hammer in cocked position.
7. Ascertain that all personnel are out of the danger area.
8. Operator may then press safety catch (31) button painted RED as far as it will go. Tool is then ready for firing. When fired safety catch automatically returns to safe position.
9. Operator fires tool by sharp pull on lanyard.
10. After observance of any safety regulations in regard to spiking procedure, operator may then unscrew breech cap (14), lift extractor (5) and remove spent cartridge. It is desirable to lift extractor after unscrewing breech cap (14) one turn only thus releasing any trapped gases (which might otherwise forcibly eject the cartridge case into operator's face).
11. Remove cable clamp (9).
12. Remove barrel, barrel base and piston punch (35) as one unit using lever between barrel base and cable to lift if necessary.
13. After day's use strip down for thorough cleaning in readiness for next spiking operations.

CLEANING GUIDE (ALL CABLE SPIKERS)

Barrel (1) is removed from barrel base (7) by tapping out the two barrel base taper pins (8). Piston punch (35) may then be withdrawn.

The cleaning tool (40) is then carefully inserted in the barrel bore and pushed right home and then rotated with firm forward pressure to remove powder deposit at breech.

Carefully wipe out barrel bore with clean but oily rag, smear light clean grease sparingly over the piston portion of the piston punch (35) and reassemble it to barrel (1).

See that the barrel base stop washer (3) is in good condition -replace it if damaged - and assemble it on top of the locating spring (36) and then place the barrel base steel washer (2) on top with its slot in line with that of the locating spring.

Assemble barrel (1) with care seeing piston punch is correctly positioned and that the marks 'V' on the barrel (1) and barrel base (7) are adjacent. Push in barrel base taper pins (8) and tap them home securely.

Carefully wipe all other components with a clean but oily rag and reassemble complete and return all equipment and cartridges to safe keeping ready for immediate future use.

Neglect to properly clean and oil each day after use and before putting away will lead to early trouble due to corrosion from acid products of combustion.

HEAVY DUTY CABLE SPIKER

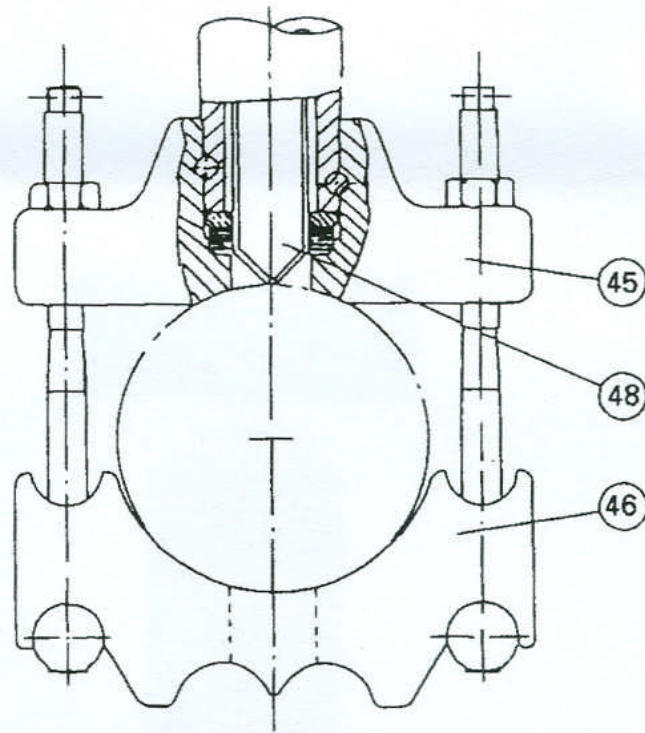

USE RED MARK (HEAVY CHARGE) CARTRIDGES

(45) BARREL BASE (46) CABLE CLAMP

(48) PISTON PUNCH.

The heavy duty cable spiker has the capacity to spike steel wire armoured cable up to 6 in. diameter. Except for the special 'large capacity' barrel base (45), cable clamp (46) and modified punch (48) the heavy duty cable spiker is the same as the standard tool.

Note: The special barrel base can only be fitted at Accles & Shelvoke Ltd., and standard tools therefore cannot be modified to heavy duty by users.

**CABLE SPIKER CONVERSION KIT
FOR USE WITH 11 kV ALUMINIUM SHEATHED CABLES
300 mm², 185 mm², 95 mm² CONDUCTOR AREAS**

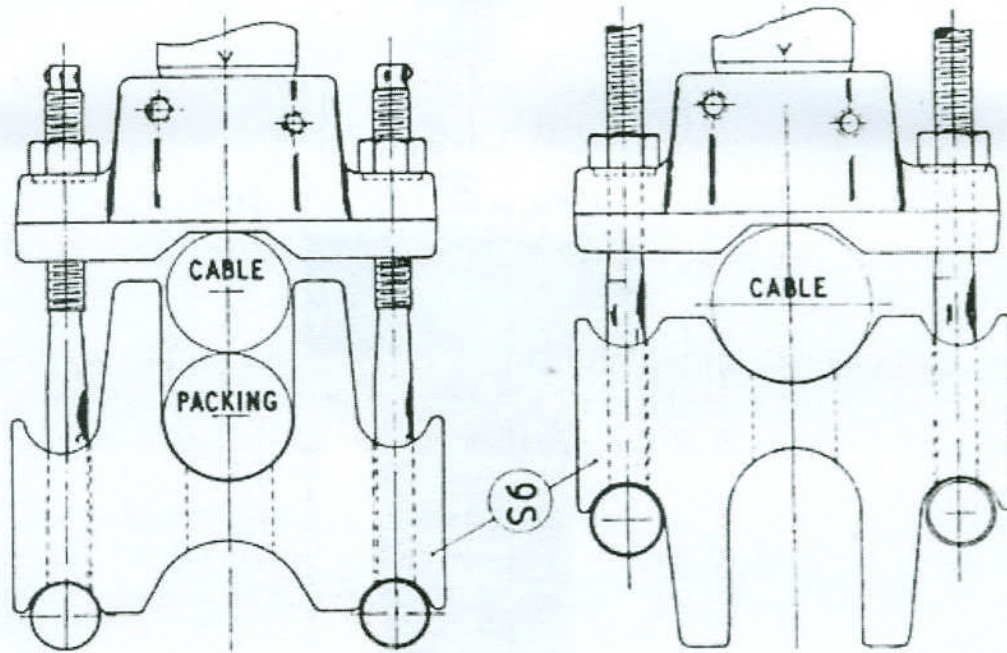

SPECIAL CLAMP 1430/9S SHOWN IN POSITION FOR 95mm² ALUMINIUM SHEATHED 11 KV CABLE WITH SCRAP 95mm² CABLE AS PACKING.

SPECIAL CLAMP SHOWN IN POSITION FOR 185MM² & 300MM² CABLE. NO PACKING REQUIRED.

The conversion kit consists of a special cable clamp part number 1430/9S which must only be used with the standard cable spiker replacing the standard cable clamp part number 1430/9. See diagram above.

The clamp is designed so that one side marked 300 and 185 takes both the 300 mm² and 185 mm² conductor area cables. Providing only the 'Super Light' cartridges are used (see under cartridge selection), no packing of this size of cable is required. The clamp is reversible to take the 95 mm² conductor area cable. It will be seen, from the diagram above, that packing is necessary when spiking this size of cable. A short length (say 4 in. long) of scrap 95 mm² cable should be used as packing by placing it under the cable to be spiked as shown in the diagram. It will be found that the scrap length cable can be used as packing more than once by moving it to a new position. If preferred, packing can be in the form of a rolled or cast billet of lead of similar diameter.

**DO NOT ATTEMPT TO SPIKE THE 95 mm² CABLE
WITHOUT PACKING OF THE TYPE
DESCRIBED ABOVE AS SERIOUS DAMAGE
WILL RESULT TO THE TOOL**

In all other respects use the cable spiker in the manner described under 'Instructions for Use (All Cable Spikers)', page 3.

CARTRIDGE SELECTION

'RED' STRENGTH (HEAVY) For use with the older types of steel wire armoured cables over 3³/₈" outside diameter, in the Standard Cable Spiker and up to 6" outside diameter in the Heavy Duty Cable Spiker.

'GREEN' STRENGTH (MEDIUM) For lead covered and all armoured cables up to 3³/₈" outside diameter.

'SILVER' STRENGTH (LIGHT) For Aluminium sheathed cables up to 300mm² and the modern small diameter plastic covered cables.

'YELLOW' STRENGTH (EXTRA LIGHT) For small polymeric type cables having no outer metallised sheath.

Important Note: Cartridge selection is of vital importance and Accles & Shelvoke Limited will not be held responsible for damage to personnel or equipment as a result of incorrect selection.

MISFIRE PROCEDURE

If the cartridge fails to fire instantaneously when struck by the firing pin, it is unlikely that a delayed explosion will occur.

However, if the tool does not fire:

1. Do not touch anything.
2. Wait three minutes.
3. Ensure that safety catch is in 'safe' position.
4. Ease breech cap one full turn only and then lift extractor to free cartridge rim from chamber.
5. Completely remove breech cap and lift out cartridge by hand.

The probable cause of the failure will be:

- (a) Weak hammer spring.
- (b) Hammer tight on bush.
- (c) Firing pin eroded.

The cartridge can safely be used or fired again once the firing mechanism of the tool has been checked. If cartridge still does not fire, then return it to Accles and Shelvoke Limited, for testing and report.

SPIKING SMALL DIAMETER CABLE

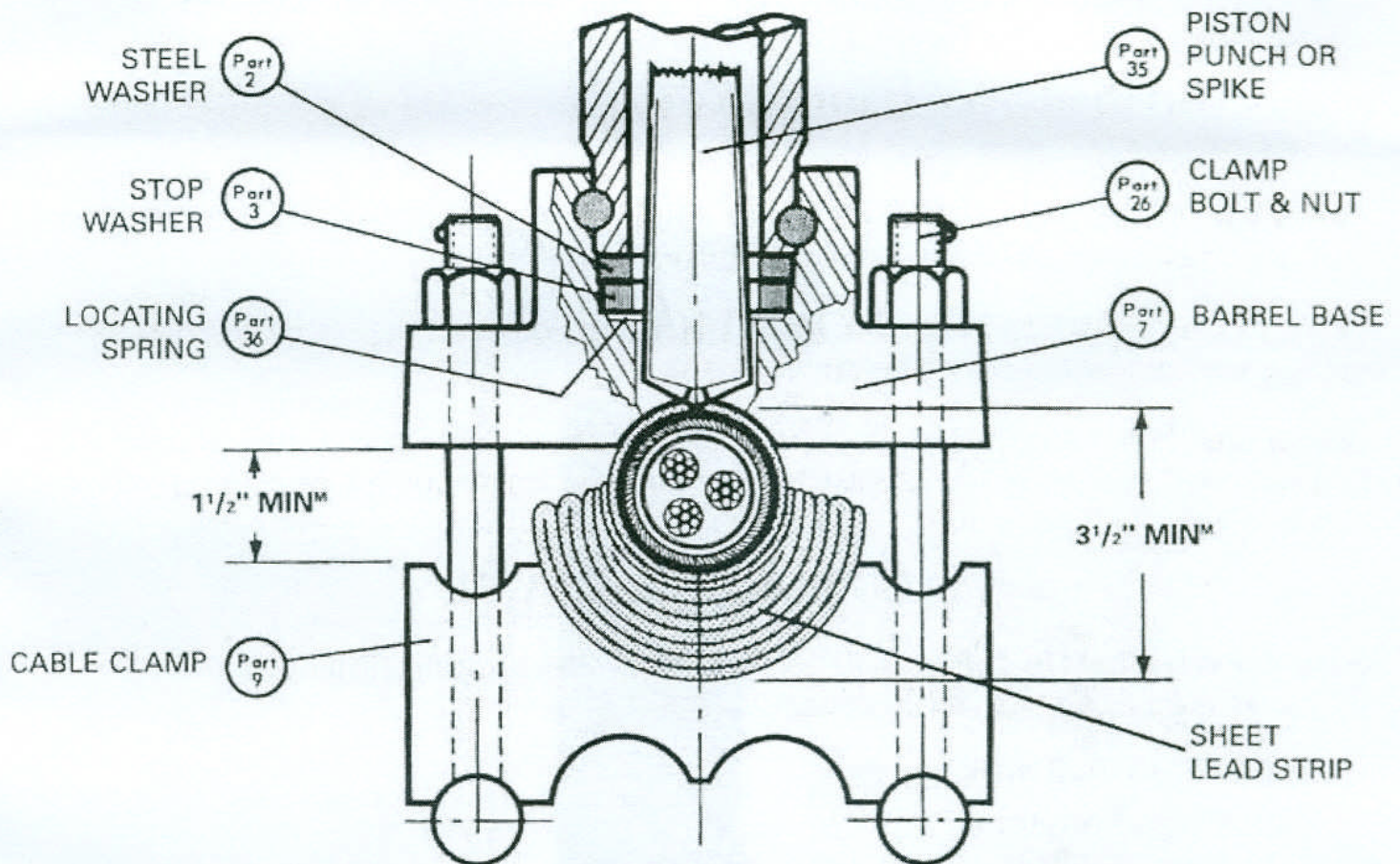

IMPORTANT

Use only Green or Silver Cartridges when Spiking small diameter cables.

Adequate and correct lead-packing is essential for trouble-free spiking of small diameter cables.

First wrap a single layer of sheet lead completely round the cable and then pack further lead strips underneath and at sides to give at least 3 1/2" of solid resistance essential to absorb the full thrust of the piston punch or spike. Equal tightening of the two clamp bolt nuts in conjunction with proper lead-packing will ensure that the barrel base is satisfactorily aligned with and spaced at least a safe 1 1/2" from the cable clamp.



WWW.CABLEJOINTS.CO.UK

THORNE & DERRICK UK

TEL 0044 191 490 1547 FAX 0044 477 5371

TEL 0044 117 977 4647 FAX 0044 977 5582

WWW.THORNEANDDERRICK.CO.UK