



Kabeldon low voltage switchgear system Product catalog 2011

Table of contents

	Page No.
Introduction	4
Fundamental technologies	5
Modern distribution technology	6
Kabeldon IP-system	7
Rugged, corrosion-resistant enclosures	8
Surface Treatment	9
Our Products	10
Planning and design program	11
Reference Pictures	12
Table of contents – Switching Devices	18
Table of contents – Enclosures	48
Technical Data	84
Designations in alphabetical order	88

Introduction



Our factory is situated in Alingsås, Sweden. The production is automated and meets stringent quality and environmental requirements.

We work to create safe electrical distribution via cable networks. To achieve this we develop, manufacture and market a broad range of cable accessories, switching devices and enclosures. Our main groups of customers are power supply companies, network companies, industrial companies and OEMs.

Our primary areas of expertise are electrical connections in cable systems and control of electrical field. Our own testing plant is an important aid to product development.

The catalog

The introductory pages show the most important products in production and in various applications. The entire range is then presented in two sections: "Switching devices" and "Enclosures", including product data.

An alphabetical list of contents can be found at the end of this catalogue. The product catalogue is also available on CD and at our website.

A separate product catalog for Kabeldon Cable Accessories 1-420 kV is available on request.

We reserve the right to alter the design and range of our products without prior notice.

Our business idea

"We provide companies that work with electric power with solutions which enable them to joint and connect cables easily and safely, and distribute electricity".

Quality and environment

Quality and environment being environmentally sound are among our top-priorities. They are important and self-evident parts of the strategic plan.

We are continuously working to improve our processes. Important foundations for this work are:

- ISO 9001 quality standard
- ISO 14001 environmental standard.



**ABB AB
Kabeldon**

Box 531, SE-441 15 Alingsås, Sweden
Tel: +46 322 770 00
Fax: +46 322 770 01
www.abb.se/kabeldon

Fundamental technologies

We work on the basis of four fundamental technologies within which we have accumulated substantial expertise over many years.

Electrical connections

The safe and secure transfer of electric current between cable conductors, or between a cable conductor and a device, requires an electrical connection of good quality. We test and develop various methods, but in most cases we use bolt technology, that gives us the possibility of offering complete solutions in line with our philosophy of easy and safe installation.

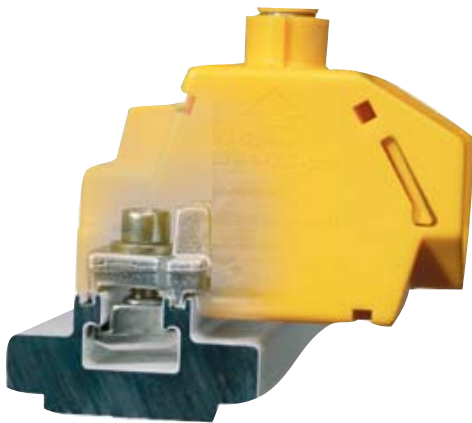

Controlling electrical fields

At high voltages the electrical fields must be controlled so that the strength of the insulation or the surrounding material is not put at risk. Depending on the voltage level, we work with different methods, e.g. geometrical, refractive or resistive field control.

Geometrical field control is achieved with premoulded stress cones and splicing blocks.

Resistive and refractive field control are achieved with special field controlling materials integrated into premoulded termination blocks.

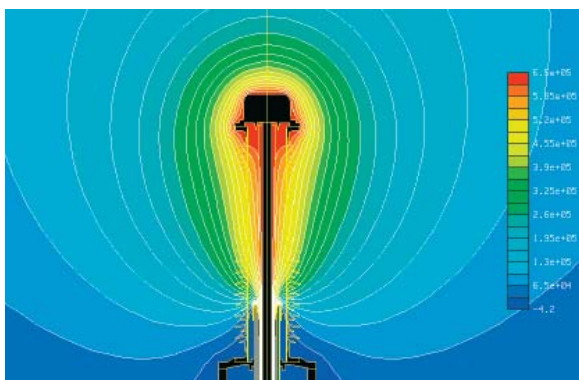

Development of creepage current resistant materials

Outdoors, cable accessories are exposed to major stresses, e.g. UV radiation from the sun and creepage currents caused by precipitation and pollution. Cable accessories are installed everywhere on the face of the planet: in humid tropical environments, in extreme cold or in the swirling salt mist of coastal regions. We develop materials and designs for outdoor use that are only minimally affected by external factors. In the case of cable terminations, it is the insulators, both in porcelain and composite material. Practical endurance tests are an important part of our development work. In addition to Weather-O-Meter, salt-mist-chamber tests and other destructive long-term tests, the products are tested under outdoor weather conditions.



Design of low voltage networks

Electrical distribution in power cable networks calls for safe and rugged products to connect cables and to withstand external factors such as humidity, vibration, etc., for a long time without causing malfunctions.

Lengthy experience of our own manufacture of switching devices and hot-dip galvanized enclosures, as well as good customer relations, means that we can quickly adapt product development to suit the needs of the market.



Distribution boards for various applications

Kabeldon low voltage distribution systems feature small dimensions, flexibility, safety, reliability and a clear layout.

The distribution board is planned with the Connect IT program, which is available for free download.

To ensure high quality, the enclosure is assembled at the factory. The enclosure is then fitted with the required devices.

It is a simple matter to wire up the distribution board and put it into service.

In indoor electrical rooms, the busbar system can also be mounted on the wall. However, we recommend an enclosed distribution board located outside, both for safety reasons and for saving valuable indoor space.

The distribution boards satisfy the requirements of:

IEC 60529, Degrees of protection provided by enclosures (IP code).

IEC 60947, Low voltage switchgear and controlgear:

- Part 1: General rules.
- Part 3: Switches, disconnectors, switch-disconnectors and fuse-combination units.

IEC 61439, Low voltage switchgear and controlgear assemblies:

- Part 1: General rules.
- Part 5: Assemblies for power distribution in public networks.

The following list shows some applications:

Utilities

- Electricity distribution in low voltage networks
- Street and road lighting; traffic lights

Buildings

- Distribution boards for hospitals, hotels, shopping malls, office buildings, etc.

Ports and airports

- Electricity supply for boats and ships
- Electricity supply for aircrafts on the ground

Sports installations

- Floodlighting for football and sports stadiums
- Lighting for jogging tracks, control panels for ski lifts, etc.

Construction sites

- Temporary electricity supply
- Central electric heating
- Distribution boards for cranes and other equipment

Temporary activities

- Electricity supply for street markets, travelling exhibitions, circuses, fairgrounds, etc.

Industry

Distribution boards to supply power to various types of industrial firms

Communication systems

- Enclosures for fibre-optic networks
- Enclosures for antenna systems and cable TV
- Terminal strips for telephony

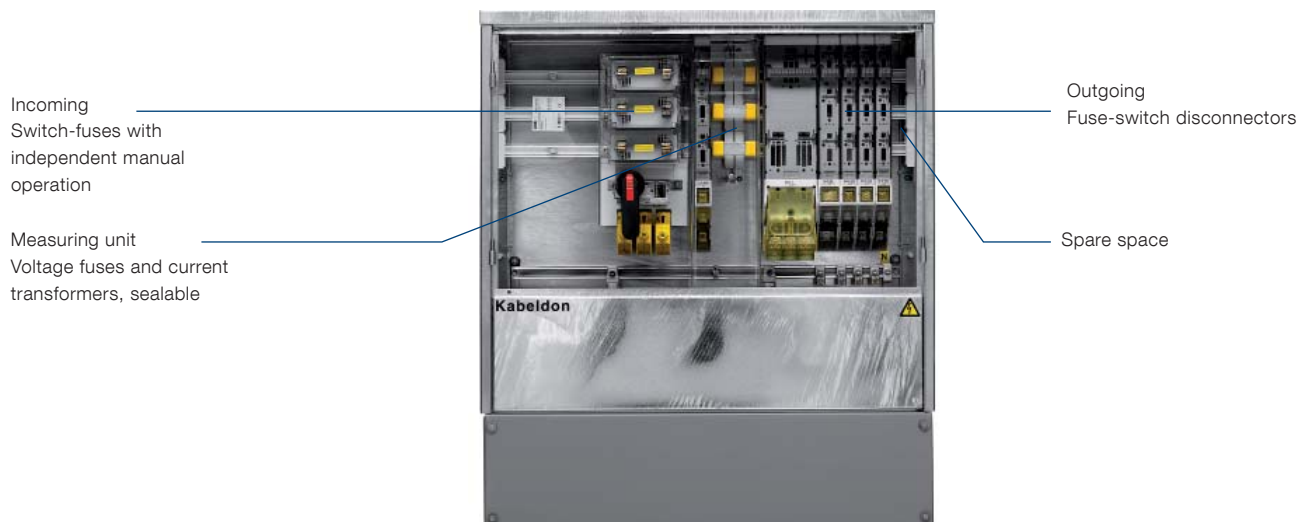

Kabeldon IP-system

Kabeldon IP-system consists of a unique, screen-protected busbar system which is combined with a broad range of switching devices and connectors.

Features of the Kabeldon IP-system are its simplicity and reliability. These are the most important factors when you want to achieve low operating costs and high delivery reliability in a distribution system.

Features:

- Busbars of continuously extruded aluminium sections, insulated with a layer of polyamid.
- The busbar has a screen-protected contact slot. This ensures safety regardless of where on the busbar the switching device is placed.
- Busbars are available with rated currents from 400 to 2500 A.
- The switching devices can be arranged in any order, regardless of rated current.

- All parts have a high degree of protection and are safe.
- Switching devices 100-1600 A.
- It is easy to add new switching devices to existing distribution boards.
- Switching devices are mounted on and connected to the busbar system in the same operation.
- Switching devices can be connected when the system is live.
- Always voltage-free ("dead") when changing fuses.
- Switching devices, connectors and busbars combine to form a modular system. Each module is 12.5 mm. The modular system makes planning easier.
- The compact design of the switching devices makes them suitable for use in many different types of distribution boards.
- All switching devices have a utilization category so that they can be used in cable distribution cabinets, substations and other distribution boards.



Rugged, corrosion-resistant enclosures

Since the 1920s, we have been manufacturing cable distribution cabinets.

The latest generation of cable distribution cabinets was developed based on our long experience of systems for demanding environments. At the same time, they satisfy current requirements for long life with undiminished safety and low operating and maintenance costs.

In Scandinavia, where snow is commonly cleared with snowploughs and where the temperature in winter can drop to -25°C or lower, stability and surface treatment must be of the highest class. Resistance to external impact is tested according to IEC 61439-5 standard. In addition, good ventilation is essential to disperse heat during the summer and to eliminate condensation.

CDC - a versatile range of enclosures with a timeless design

CDC was developed in close collaboration with users and meets the requirements for simplicity and flexibility. A number of practical functions make the installer's work easier. They can also be used for broadband systems using fibre-optic cables, for telephone installations and cable TV.



Hot-dip galvanized enclosure type CDC.



Hot-dip galvanized enclosure type SDC.

SDC - versatile enclosure with extra depth

This enclosure is designed for both indoor and outdoor distribution boards.

SDC is hot-dip galvanized and has a design that harmonizes well with the CDC series, so that the two can be used together. There is also a variant with a top section for meters or other equipment.

KSİK - powder coated enclosure

Suitable enclosure for indoor distribution boards in environment classes C_1^* and C_2^* e.g. in industry, buildings, sports facilities, and warehouses.

KSİK has special openings on the sides, for easy assembly with putting through busbar systems.

* In accordance with ISO 12944-2

C_1 = Heated, dry rooms.

C_2 = Small amounts of humidity may occur.



Powder coated enclosure type KSİK.

Surface treatment

CDC and SDC enclosures are made of sheet steel and are protected against corrosion by hot-dip galvanizing according to ISO 1461. For parts that are buried in the ground, the corrosion protection has been reinforced with a polymer coating. To make sure that the polymer coat adheres to the hot-dip galvanized surface, it has undergone zinc/manganese phosphating.

The above treatment gives excellent protection against corrosion, so that the life of the enclosures is very long in the most commonly occurring environments for outdoor enclosures.



Six protective coats for outstanding corrosion protection of steel in the ground

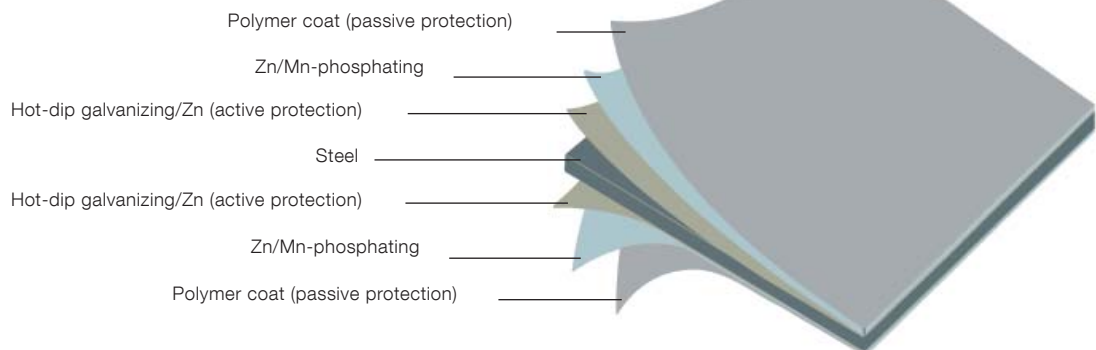

Our products



Enclosures for various fields of application.



Cable distribution cabinets with switching devices and busbar systems.

Planning and design program Connect IT

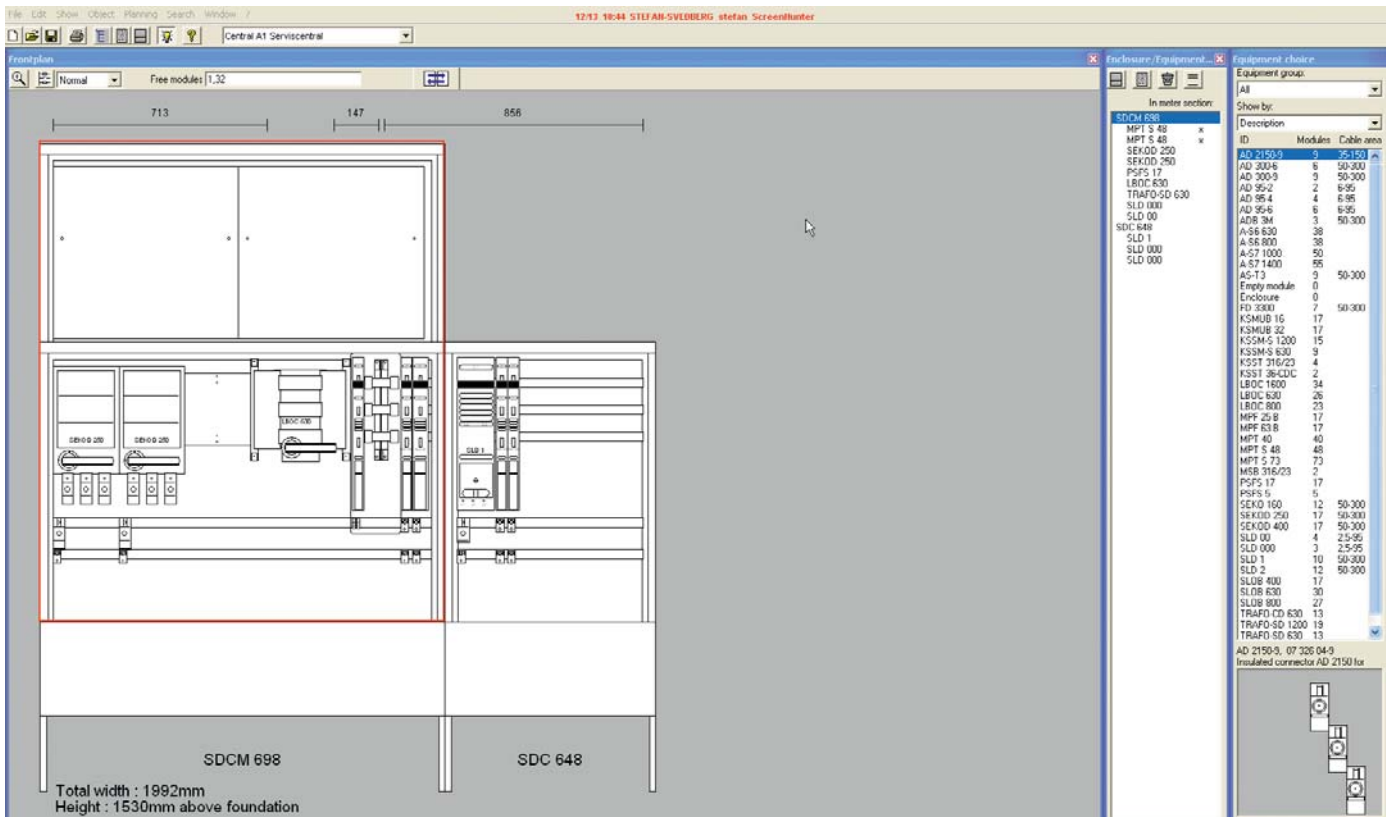

Front panel sketch of complete cabinet created in Connect IT.

Connect IT planning program

Connect IT is a Windows®-based planning program for cable distribution cabinets, service distribution boards and other applications based on the range of switching devices, busbar systems and enclosures.

Connect IT makes it easy to design an electrical distribution board and to obtain details of its components as follows:

- Enclosures with accessories
- Busbar system
- Switching devices and connection
- Own hardware added, e.g. fuses

Connect IT also generates information for ordering, planning and documentation.

- A single-line diagram, to which addresses, cable data and other details can be added.
- A front panel sketch, which can be used as a basis for component mounting.

Connect IT runs in a 32-bit environment and therefore requires Windows® operative system.

Connect IT offers great scope to freely create any desired combination of switching devices and enclosures. The work is done quickly and simply, with the aid of pictures and text.

A customer database can be linked to the program making it well-suited for tendering.

Connect IT is also suitable for use when planning a busbar system without enclosure, e.g. for installation in electrical operating areas.

Connect IT is available for free download at: www.abb.se/kabeldon.

Contact us for further information and to place your order!

Reference pictures

Manufacturing, surface treatment and assembling



Fully-automatic plant for pressing, punching and bending of metal plates.



Production of switching devices and connectors with modern technology.



Assembly of distribution boards.



Powder coating of foundation parts.



Assembly of enclosures.



Automatic hot-dip galvanizing plant.



Automatic pre-treatment of enclosures before powder coating.



Treatment for outgoing waste water from surface treatment.

Reference pictures



Kabeldon switching devices in a switchgear.



Cable distribution cabinet, Alingsås, Sweden.

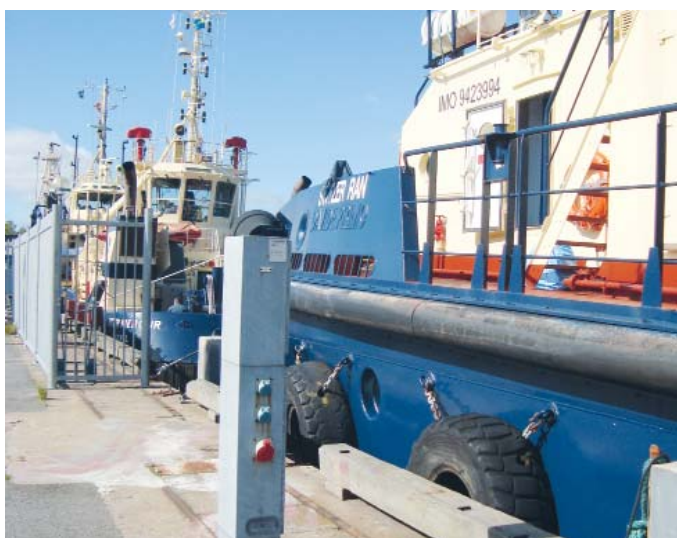

Permanent central for temporarily using by the new shipyard in Gothenburg, Sweden.



Cable distribution cabinet, Brunnsparken, Gothenburg, Sweden.



Cable distribution board used for streetlighting near Kalmar cathedral, Sweden.



Cable distribution board in Malmö, Sweden.

Reference pictures



Kabeldon switching devices in substation distribution, Latvia.



Outside the entrance to First Hotel Christian IV in Kristianstad. Cable distribution cabinet for street lighting.



Cable distribution board in powder coated enclosure mounted on the wall at the bakery shop in Gothenburg, Sweden.



Kabeldon cable distribution cabinet, Vietnam.



Cable distribution board in Slottsskogen, Gothenburg, Sweden.



Kabeldon cable distribution cabinet nearby Alingsås library, Sweden.

Reference pictures



Cable distribution cabinet in a in Alingsås, Sweden.



Cable distribution boards at Hedens bandy rink, Gothenburg, Sweden.



Distribution board serving the swing bridge to Kockum's area at the old shuttle boat terminal in Malmö, Sweden.

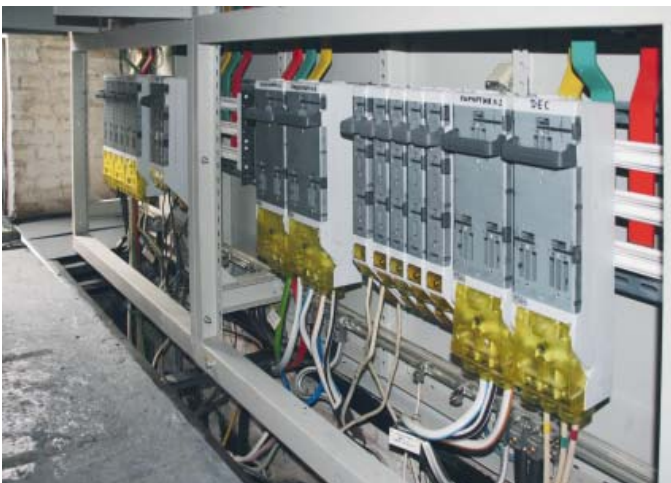

Kabeldon low voltage products in a switchgear, Ukraine.



Junction box installed in Bristol, England. This replaces the conventional underground junction box.

Reference pictures



Cable distribution cabinet, Säby, Sweden.



Street lighting, eastern cemetery, Gothenburg, Sweden.



Cable distribution board, Malmgård, Finland.



Cable distribution board, Mc Donald's, Sweden



Cable distribution cabinet in Varberg's housing area, Sweden.

Reference pictures

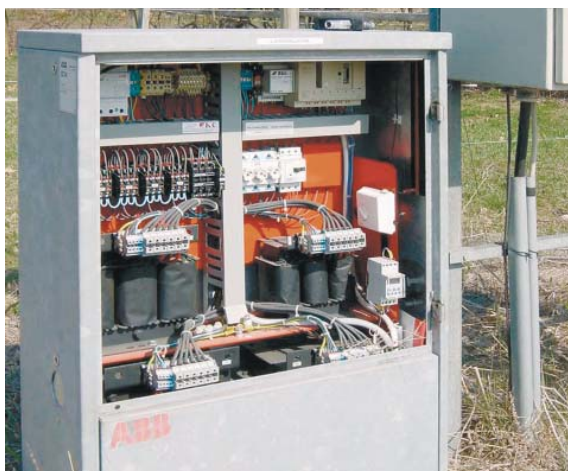

Kabeldon enclosure used for control equipment for adjustment of roundabout illumination at the entrance to Kalmar (E22), Sweden.



Cable distribution cabinets used for electricity and fibre optic networks.



In Jönköping, Sweden, a CDC enclosure has been used for the water supply for the trade fair site.

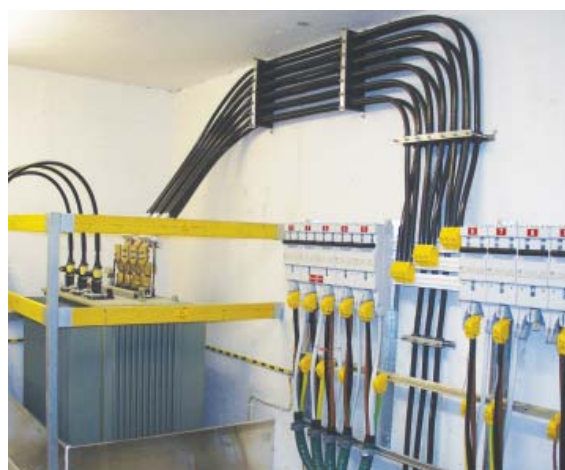

Kabeldon low voltage products mounted directly on a wall in a substation in Trondheim, Norway.



Junction box installed in Bristol, England.



Temporary service distribution boards for the "Eurovision Song Contest 2003" in Riga, Latvia.

Table of contents

Switching Devices

	Page No.
Standard for switching devices	19
Switching devices with dependent manual operation	20
Switching devices with independent manual operation	26
Connectors	29
Busbar systems with accessories	30
General accessories for OEM	37
General accessories	39
Dimension drawings	43

Standard switching devices

Utilization category

The utilization category for the switching devices is stated in the technical data for each product.

Rated diversity factor

For switching devices mounted in a cable distribution cabinet, distribution board or directly on the wall; the rated current must be reduced where there are parallel current paths.

Number of main circuits	Rated diversity factor
2 and 3	0.9
4 and 5	0.8
6-9	0.7
10 and above	0.6

Rated current for phase- and neutral busbars.

The stated rated current refers to the highest permitted current in any section of the busbar.

Voltage testing

All of the devices have apertures designed for voltage testers conforming to IEC 61243-3.

Connectors

All switching devices come complete with terminal connectors for both copper and aluminium conductors. Connectors for aluminium conductors have been tested to Swedish Standard SEN 24 15 10 equivalent to VDE 0220/1 or IEC 61238-1.

The torque range depends on the conductor cross-section, please see "Technical data" or installation instructions. Normally it's no need to any retightening but it may be required in special situations, i.e. when a short-circuit has happened.

Area range

The stated area range refers to connection with a stranded or solid conductor. When connecting a flexible conductor, reduce the max. area by one area step.

Parallel conductors

The connectable area for parallel conductors is determined by dividing the maximum area by the number of parallel conductors and reducing by one more area step.

Ex: max cable connection 300 mm²,
300/2 ⇒ 150 go down by a step ⇒ 120.

Modular system

The dimensions of all items that can be connected to the busbar system are based on a module (one module M = 12.5 mm). This makes it easy to calculate the space required by a particular distribution board and then to choose a suitable enclosure.

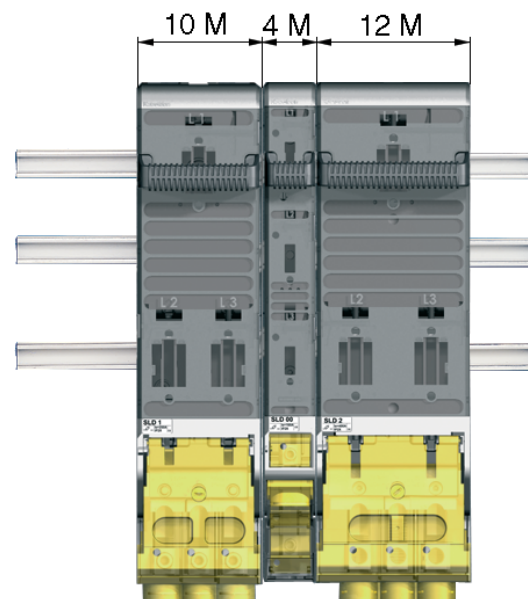
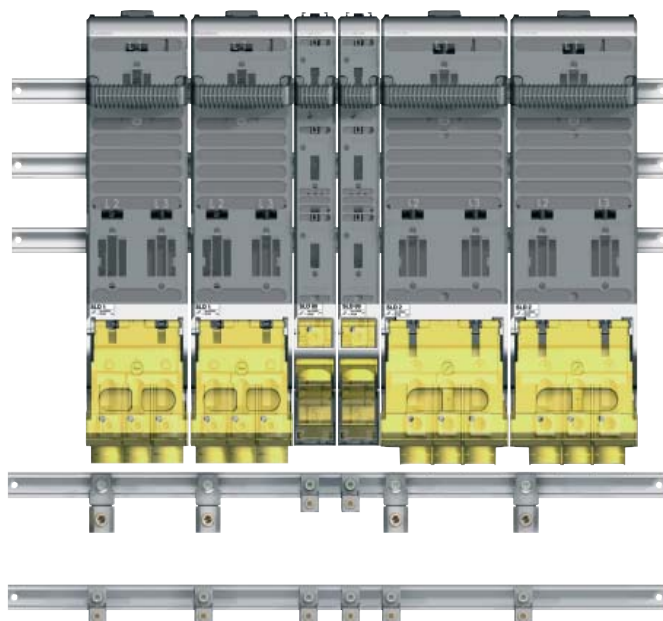

Switching devices with dependent manual operation

SLD 000



SLD 000
Fuse-switch disconnecter.

- AC-23B according to IEC 60947-3
- 3 modules or 38 mm width
- Fuse NH 000 or C00
- Sealing possibility



JDDA 000
Earthing device.



KSBD 00
Blocking device.



KN 00
Linking knife



FHHD-A 000
Kit with detachable handle and adapter for fuse-switch disconnecter SLD 000. With this solution the depth is reduced with 35 mm.



FHH
Detachable handle to FHHD-A 000, SLC-FHD 00 and FHD 00.

Designation	ID No.	Degree of protection	Qty modules	Rated data		Cable connection Al/Cu mm ²	Qty a kit	Weight kg/each
				400 V	690 V			
SLD 000	2CGX0 63050106	IP2X*	3	100 A	80 A	2.5-95**	1	1.7

To be ordered separately:

Designation	ID No.	Qty modules	Rated data	Qty a kit	Weight
					kg/each
JDDA 000	2CGX0 63190375	3	6.1 kA/1 s	1	2.2
KSBD 00	2CGX0 63190109	-	-	3	0.1
KN 00	2CGX0 53190319	-	160 A	3	0.1
FHHD-A 000	2CGX0 53050205	-	-	1	0.02
FHH	2CGX0 43050404	-	-	1	0.02

*IP1X with open device, depending on design of fuse.

**Max area refers to connection with a stranded or solid conductor.

Switching devices with dependent manual operation

SLD 00



SLD 00
Fuse-switch disconnectors.

- AC-23B according to IEC 60947-3
- 4 modules or 50 mm width
- Fuse NH 00
- Sealing possibility



JDDA 00
Earthing device.



KSBD 00
Blocking device.



KN 00
Linking knife



FHHD-A 00
Kit with detachable handle and adapter for fuse-switch disconnectors SLD 00. With this solution the depth is reduced with 35 mm.



FHH
Detachable handle to FHHD-A 00, SLC-FHD 00 and FHD 00.

Designation	ID No.	Degree of protection	Qty modules	Rated data		Cable connection Al/Cu mm ²	Qty a kit	Weight kg/each
				400 V	690 V			
SLD 00	2CGX0 63050107	IP2X*	4	160 A	160 A	2.5-95**	1	1.8

To be ordered separately:

Designation	ID No.	Qty modules	Rated data	Qty a kit	Weight kg/each
JDDA 00	2CGX0 63190376	4	6.1 kA/1 s	1	2.3
KSBD 00	2CGX0 63190109	-	-	3	0.1
KN 00	2CGX0 53190319	-	160 A	3	0.1
FHHD-A 00	2CGX0 53050204	-	-	1	0.03
FHH	2CGX0 43050404	-	-	1	0.02

*IP1X with open device, depending on design of fuse.

**Max area refers to connection with a stranded or solid conductor.

Switching devices with dependent manual operation

SLD-FHD



FHD 000

The kit contains three single-pole fuseholders and one handle. Replaces the cover to SLD 000 when single-pole breaking.



FHD 00

The kit contains three single-pole fuseholders and one handle. Replaces the cover to SLD 00 when single-pole breaking.

SLD-FHD 000

Fuse-switch disconnector

- Three single-pole fuse-holders.
- Blade fuses type C00, NH 000 or linking knife KN 00.

SLD-FHD 00

Fuse-switch disconnector

- Three single-pole fuse-holders.
- Blade fuses type typ NH 00 or linking knife KN 00.

Designation	ID No.	Degree of protection	Qty modules	Rated data	Cable connection	Qty a kit	Weight
					Al/Cu mm ²		kg/each
SLD-FHD 000	2CGX0 63050116	IP2X*	3	230 V, 100 A	2.5-95**	1	1.76
SLD-FHD 00	2CGX0 63050117	IP2X*	4	230 V, 160 A	2.5-95**	1	1.89
FHD 000	2CGX0 53050225	IP2X*	3	230 V, 100 A	-	3	0.10
FHD 00	2CGX0 53050226	IP2X*	4	230 V, 160 A	-	3	0.12

*IP1X with open device, depending on design of fuse.

**Max area refers to connection with a stranded or solid conductor.

Switching devices with dependent manual operation

SLD 1



SLD 1
Fuse-switch disconnecter.

- AC-23B according to IEC 60947-3
- 10 modules or 120 mm width
- Fuse NH 1 (max width 42 mm)



JDDA 1
Earthing device for SLD 1.



KSBD 2
Blocking device.



KN 1
Linking knife.



STM 400
Conductor rail with connector for current transformer metering.
Dimensions of conductor rail are: 25x13 mm.

Designation	ID No.	Degree of protection	Qty modules	Rated data		Cable connection	Weight
				400 V	690 V	Al/Cu mm ²	
SLD 1	2CGX0 63050108	IP2X	10	250 A*	250 A	50-300**	4.3

To be ordered separately:

Designation	ID No.	Degree of protection	Rated data	Dimensions			Cable connection	Qty a kit	Weight
				H	B	D			
				mm					Al/Cu
JDDA 1	2CGX0 63190402	–	16.2 kA/1 s	–	–	–	–	1	0.4
KSBD 2	2CGX0 63190110	–	–	–	–	–	–	3	0.1
KN 1	2CGX0 53190345	–	400 A	–	–	–	–	3	0.2
STM 400	2CGX0 63090026	IP2X	400 V, 400 A	220	35	85	50-300	1	0.4

*250 A with fuse, 400 A with linking knife.

**Max. area refers to connection with a stranded or solid conductor.

Switching devices with dependent manual operation

SLD 2



PHD 2
Parallel handle for parallel operation of two SLD 2 in enclosures CDC.



PHD 2 SDC
Parallel handle for parallel operation of two SLD 2 in enclosures SDC.



JDDA 2
Earthing device.



STM 400
Conductor rail with connector for current transformer metering. Dimensions of conductor rail: 25x13 mm.

SLD 2

Fuse-switch disconnector

- AC-23B according to IEC 60947-3
- 12 modules or 150 mm width
- Fuse NH 2
- Possibility for parallel operation
- Tested up to 1000 V for installation in dry indoor environments.
- When using SLD 2 in 1000V systems, fuses that are designed for 1000 V must be used.



KSBD 2
Blocking device.



KNB 2
Linking knife.

Designation	ID No.	Degree of protection	Qty modules	Rated data when voltage level			Cable connection	Weight
				400 V	690 V	1000 V		
				A			AI/Cu	
SLD 2	2CGX0 63050109	IP2X	12	400	355	160	50-300*	4,6

*Max. area refers to connection with a stranded or solid conductor.

To be ordered separately:

Designation	ID No.	Degree of protection	Rated data	Dimensions			Cable connection	Qty a kit	Weight
				H	B	D			
				mm			AI/Cu		
JDDA 2	2CGX0 63190401	-	16.2 kA/1 s	-	-	-	-	1	2.5
PHD 2	2CGX0 63090024	-	-	-	-	-	-	1	1.5
PHD 2 SDC	2CGX0 63090023	-	-	-	-	-	-	1	1.5
KSBD 2	2CGX0 63190110	-	-	-	-	-	-	3	0.1
KNB 2	2CGX0 53190321	-	630 A	-	-	-	-	3	0.2
STM 400	2CGX0 63090026	IP2X	400 V, 400 A	220	35	85	50-300	1	0.4

Disconnecter with dependent manual operation FD 3300



FD 3300
Disconnecter.



KFB D
Blocking device.

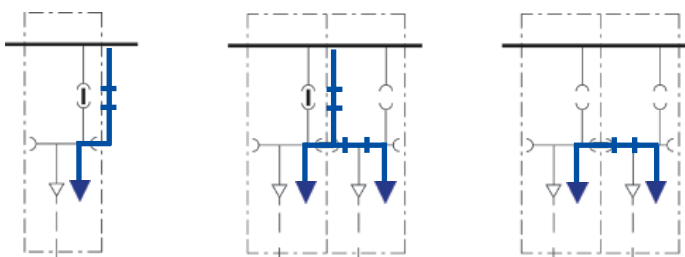
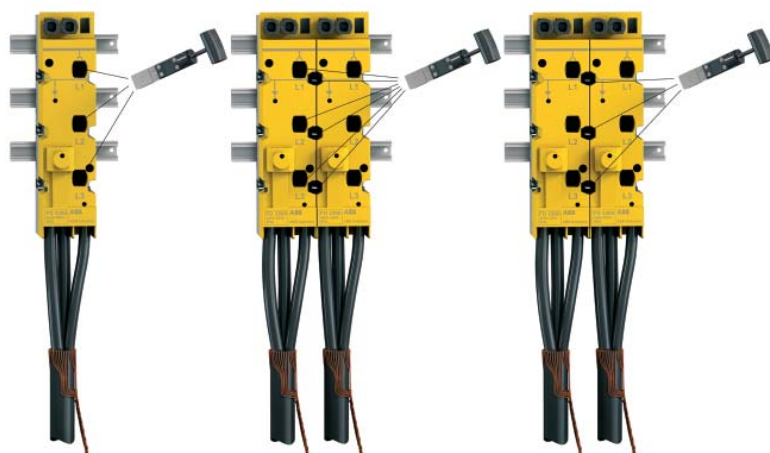

Disconnecters are intended for single-pole breaking. By using the linking knives between adjacent disconnecters, the busbar system can be disconnected without stopping the current from the incoming cable passing through.

Designation	ID No.	Degree of protection	Qty modules	Rated data	Cable connection	Weight
					Al/Cu mm ²	kg/each
FD 3300	2CGX0 63030032	IP2X	7	500 V, 400 A	50-300*	2.6

To be ordered separately:

Designation	ID No.	Weight
		kg/each
KFB D	2CGX0 63190112	0.1

* Max. area refers to connection with a stranded or solid conductor.

Switching devices with independent manual operation SEKO, SEKOD

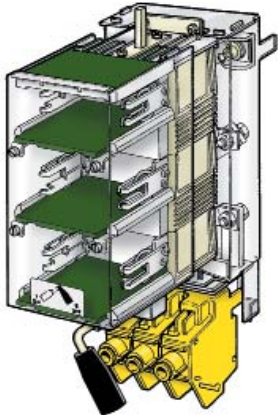

SEKO 160
Switch-fuse with breaking on both sides of the fuse.



SEKOD 250
Switch-fuse with breaking on both sides of the fuse. Here SEKOD 250 in OFF position.



SEKOD 400
Switch-fuse with breaking on both sides of the fuse. Here SEKOD 400 in OFF position.

Switch	Select
160 A	SEKO 160 + KN 00
250 A	SEKOD 250 + KN 1
400 A	SEKOD 400 + KN 1

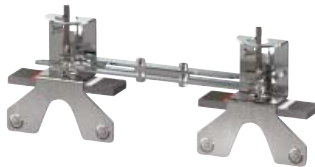

ILM 250
Interlocking mechanism for SEKOD 250.



ILM 400
Interlocking mechanism for SEKOD 400.



PSM 250
Parallel handle for SEKOD 250.



KN 1
Linking knife.



KN 00
Linking knife.

Designation	ID No.	Qty modules	Rated current	Cable connection	Fits in enclosures	Suitable fuse size	Weight
			A	Al/Cu mm ²			kg/each
SEKO 160	2CGX0 63050051	12	160	50-300*	KSIK, CDC, SDC	NH 00	5
SEKOD 250	2CGX0 63050234	17	224	50-300*	KSIK, SDC	NH 0, NH 1	5.2
SEKOD 400	2CGX0 63050235	17	355	50-300*	KSIK, SDC	NH 1, NH 2	8.2

* Max. area refers to connection with a stranded or solid conductor.

To be ordered separately

Designation	ID No.	Rated current	Qty. per pack	Weight
		A		kg/each
ILM 250	2CGX0 63090032	-	1	0.8
ILM 400	2CGX0 63090034	-	1	0.6
PSM 250	2CGX0 63090031	-	1	0.7
KN 00	2CGX0 53190319	160	3	0.1
KN 1	2CGX0 53190345	400	3	0.2

Switching devices with independent manual operation SLOB, LBOC

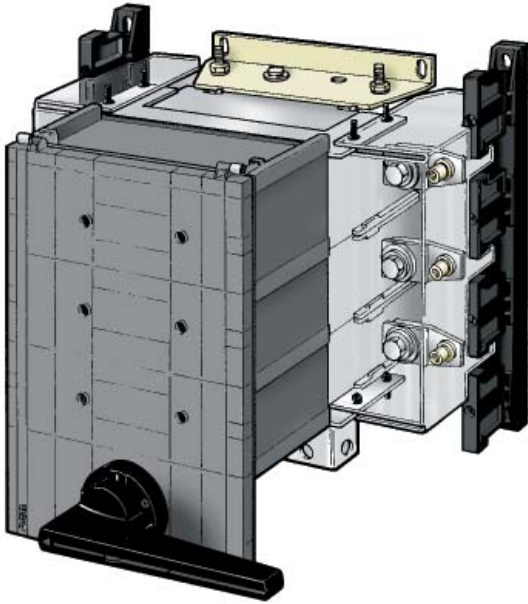

SLOB 400, 630, 800
Section switch-fuse with breaking
on both sides of the fuse.

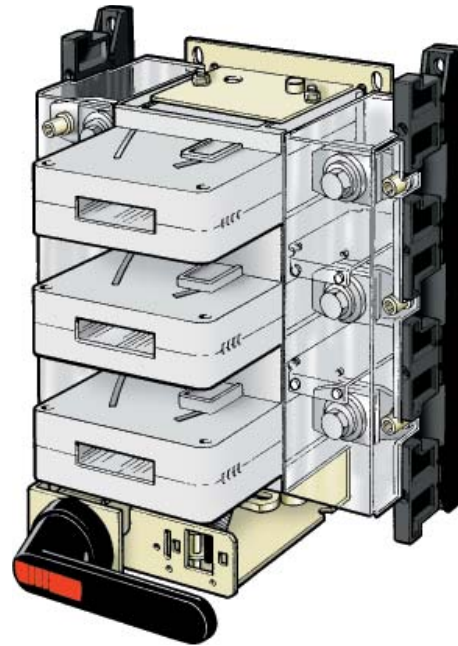

LBOC 630, 800, 1600
Section switch without fuse.

Note:

To mount SLOB 800, LBOC 800 and 1600 the busbar system must be split*. For switching devices with rated current 800 A and 1600 A the busbar ends must be treated.

* To be completed with busbar support.

Designation	ID No.	Qty modules	Rated current	Fits in enclosure	Suitable fuse size	Weight kg/each
			A			
SLOB 400*	2CGX0 63050097	17	400	KSIK, SDC	0-2	8,6
SLOB 630	2CGX0 63050101	30	630	KSIK, SDC	3	15
SLOB 800	2CGX0 63050102	27	800	KSIK, SDC	3	15
LBOC 630	2CGX0 63050103	27	630	KSIK, SDC	-	8
LBOC 800	2CGX0 63050104	23	800	KSIK, SDC	-	8
LBOC 1600	2CGX0 63050105	34	1600	KSIK, SDC	-	18

* Busbar support as accessory is to be ordered separately.

Adapter plates for module case circuit breakers (MCCB) T3 and T5



AS-T3

Adapter for circuit-breaker type Tmax T3 for 250 A from ABB SACE.

- Degree of protection IP2X.
- Allows circuit-breakers to be mounted on a live busbar system.
- Fits all Kabeldon busbars.
- Fits Kabeldon enclosures.
- Meets the requirements of IEC 60947-1.



KLAP T5 630

Adapter plate for plug-in socket to circuit-breaker Tmax T5 630 for 570 A from ABB Sace.

- Fits all Kabeldon busbars.
- Meets the requirements of IEC 60947-1.
- Doesn't fit in Kabeldon enclosures.
- To be mounted when disconnected

Note:

Circuit-breaker is not included! For complete resolution the additional should be ordered:

- Adapter plate AS-T3
- Circuit-breaker T3 250 – Fixed – 3-pole
- Conversion kit from fixed to Plug-in, 1 SD AO 51413 R1

Note:

Circuit-breaker and plug-in socket is not included.

For complete resolution the additional should be ordered:

- Adapter plate KLAP T5 630
- Circuit-breaker T5 630 – Fixed – 3-pole
- Conversion kit from fixed to Plug-in, 1SDA 054847 R1
- Socket, 1SDA 054762 R1
- Connector



Molded-case circuit-breaker Tmax T3, is mounted on adapter plate AS-T3.



Molded-case circuit-breaker Tmax T5 and plug-in socket, mounted on adapter plate KLAP T5 630.

Note:

- only the adapter plates are included in Kabeldon supply.
- For more information, please contact your local ABB supplier.

Designation	ID No.	Qty modules	Rated data	Cable connection Al/Cu	Dimensions with mounted circuit-breaker			Weight kg/unit
					Height	Width	Depth	
AS-T3	2CGX0 63050093	9	690 V, 250 A	300	325	113	190	2.1
KLAP T5 630	2CGX0 53050209	12	400 V, 525 A	-	395	150	296	3.0

Connectors



ADC 25
Non-insulated connector.
May only be used with non-protected busbars for 1.5-25 mm² conductor.



AD 70
Non-insulated connector.
May only be used with non-protected busbars for 6-95 mm² conductor.



ADO 240
Non-insulated connector.
May only be used with non-protected busbars for 120-240 mm² conductor.



AD 350
Non-insulated connector for connecting three separate conductors, each max 50 mm² Al/Cu.
May only be used with non-protected busbars.



AD 95
Insulated connector.

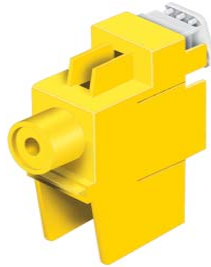

AD 2150
Insulated connector for parallel conductors.



AD 300
Insulated connector.



AD 400
Insulated connector.



ADB 3M
Insulated connector for compact fitting of AD 300 for 3 phases.



KSBH 300
Cover for disconnected cable, for protection against accidental contact, with AD 300 or AD 2150.



ADN
Spacer for PEN bar, used with AD 300.

Note:
Switching devices and connectors must be tightened to the recommended torque.

Designation	ID No.	Qty modules	Width mm	Rated data	Degree of protection	Cable connection Al/Cu	Qty per pack	Weight kg/each
						mm ²		
ADC 25	2CGX0 63030233	–	14	63 A	–	1,5-25	50	0.1
AD 70	2CGX0 63030038	–	23	200 A	–	6-95	50	0.1
ADO 240	2CGX0 63030263	3	30	400 A	–	120-240	1	0.25
AD 350	2CGX0 63030262	–	38	400 A	–	3 x 6-50	25	0.2
AD 95	2CGX0 79000011	2	25	690 V, 200 A	IP2X	6-95	3	0.1
AD 2150	2CGX0 63030037	3	38	690 V, 400 A	IP2X	35-2//150	3	0.2
AD 300***	2CGX0 63030195	3	38	690 V, 630 A	IP2X	50-300	3	0.2
AD 400	2CGX0 63030267	3	42	690 V, 630 A	IP2x	50-400	3	0,47
ADB 3M**	2CGX0 63030258	3	38	500 V, 500 A	IP2X	–	1	0.7
KSBH 300	2CGX0 63190111	–	46	–	–	–	3	0.1
ADN	2CGX0 63030231	–	37	500 A	–	–	1	0.3

*Max area refers to connection with a stranded or solid conductor.

** ADB 3M to be supplemented with three AD 300.

*** Three-phase connection, 6-9 modules.

Busbar systems with accessories

With protection (IP2X) against accidental contact



KSFS 420-473
400 A.



KSFS 1083-10126
1000 A.



KSFS 640 A-698 A
630 A.



KSFS 1683-16181
1600 A.

Note:

The stated rated current is the maximum current in any part of the busbar.

Designation	ID No.	Qty modules	Rated current	Suitable busbar support		Length	Weight
				KSST 36	KSST 316		
				KSST 316/23		mm	kg/m
				KSST 316/100			
				A			
KSFS 420	2CGX0 43320260	20	400	x	x	284	0,6
KSFS 440	2CGX0 43320261	40	400	x	x	534	0,6
KSFS 443	2CGX0 43320037	43	400	x	x	569	0,6
KSFS 448	2CGX0 43320258	48	400	x	x	636	0,6
KSFS 460	2CGX0 43320262	60	400	x	x	784	0,6
KSFS 463	2CGX0 43320038	63	400	x	x	809	0,6
KSFS 473	2CGX0 43320264	73	400	x	x	950	0,6
KSFS 640 A	2CGX0 43320363	40	630	x	x	534	0,9
KSFS 643 A	2CGX0 43320367	43	630	x	x	569	0,9
KSFS 648 A	2CGX0 43320365	48	630	x	x	636	0,9
KSFS 660 A	2CGX0 43320364	60	630	x	x	784	0,9
KSFS 663 A	2CGX0 43320368	63	630	x	x	809	0,9
KSFS 673 A	2CGX0 43320369	73	630	x	x	950	0,9
KSFS 698 A	2CGX0 43320366	98	630	x	x	1264	0,9
KSFS 1083	2CGX0 43320145	83	1000	-	x	1079	1,6
KSFS 1098	2CGX0 43320156	98	1000	-	x	1264	1,6
KSFS 10126	2CGX0 43320146	126	1000	-	x	1600	1,6
KSFS 1683	2CGX0 43320152	83	1600	-	x	1079	3,0
KSFS 1698	2CGX0 43320158	98	1600	-	x	1264	3,0
KSFS 16126	2CGX0 43320153	126	1600	-	x	1600	3,0
KSFS 16149	2CGX0 43320154	149	1600	-	x	1890	3,0
KSFS 16181	2CGX0 43320155	181	1600	-	x	2300	3,0

Busbar systems with accessories

Without protection (IP00) against accidental contact (type PEN, PE and N)



KSNS 417-498
400 A.



KSNS 1083-10181
1000 A.

Designation	ID No.	Qty modules	Rated current	Length	Weight
			A	mm	kg/m
KSNS 417	2CGX0 43320059	17	400	209	0.6
KSNS 420	2CGX0 43320192	20	400	333	0.6
KSNS 440*	2CGX0 43320193	40	400	585	0.6
KSNS 443	2CGX0 43320052	43	400	569	0.6
KSNS 460	2CGX0 43320194	60	400	835	0.6
KSNS 463	2CGX0 43320053	63	400	809	0.6
KSNS 473	2CGX0 43320196	73	400	900	0.6
KSNS 498	2CGX0 43320190	98	400	1214	0.6
KSNS 498 KSIK	2CGX0 43320195	98	400	1266	0.6
KSNS 1083	2CGX0 43320162	83	1000	1079	1.6
KSNS 1098	2CGX0 43320169	98	1000	1212	1.6
KSNS 1098 KSIK	2CGX0 43320343	98	1000	1264	1.6
KSNS 10126	2CGX0 43320163	126	1000	1600	1.6
KSNS 10149	2CGX0 43320164	149	1000	1890	1.6
KSNS 10181	2CGX0 43320165	181	1000	2300	1.6

* KSNS 440 is used with SDC X48 and CDC X40.

Busbar systems with accessories

Busbar supports



KSST 36
Support for 400 A and 630 A busbars. Fixing hole pitch 85 mm.
To split busbar systems for metering with current transformers, etc.



KSST 316, 316/23, 316/100
Support for 400 A, 630 A, 1000 A and 1600 A busbars. Primarily in enclosures type SDC.



KSST-CDC
Support for 400 and 630 A busbars when mounting in enclosure type CDC.
The kit consists of two complete supports and also four fixing bolts.



KSST 36-CDC
Support for 400 A and 630 A phase bars. Fixing hole pitch is 85 mm. Used in split and shortened busbar systems in CDC enclosures.



KLKB-S 630, 1200
Bar bridge to interconnect busbar systems in two enclosures. May only be installed on dead busbar.

Designation	ID No.	Rated current	Free space behind the bars	Qty modules	Suitable enclosures	Weight kg/each
		A	mm			
KSST 36	2CGX0 53320186	–	11	2	all	0.1
KSST 36-CDC	2CGX0 53320187	–	15	2	CDC	0.3
KSST-CDC	2CGX0 53320231	–	15	–	CDC	0.4
KSST 316	2CGX0 53320104	–	9	2	all	0.5
KSST 316/23	2CGX0 53320106	–	23	2	all	0.8
KSST 316/100	2CGX0 53320105	–	100	2	SDC	1.1
KLKB-S 630	2CGX0 51190106	630	–	–	all	3.4
KLKB-S 1200	2CGX0 51190107	1200	–	–	SDC	6.6

Busbar system with accessories

Middle support for 400-1600 A busbars



MSB 316
Middle support fits to KSST 316.
Made from non-magnetic stainless steel.



MSB 316/23
Middle support fits to KSST 316/23.
Made from non-magnetic stainless steel.



MSB 316/100
Middle support fits to KSST 316/100. Made from non-magnetic stainless steel.

Note:

To meet the requirements of short circuit strength, the maximum distance between two busbars should be 1 meter, see information "Technical data" in this catalog. If the distance is 1 meter or longer, a middle support must be used at a suitable place.

Designation	ID No.	Free space behind the busbars	Qty modules	Weight
		mm		kg/each
MSB 316	2CGX0 53320201	9	1	0.5
MSB 316/23	2CGX0 53320202	23	1	0.8
MSB 316/100	2CGX0 53320203	100	1	1.2

Busbar system 1600 A

1600 A busbar system for use in substations, low voltage switchgears and distribution boards.

The system has been tested for up to 30 kA short-circuit current.

Simple to connect power supply at rear with connection washer, AB 2500 CSS without modification to the busbar. Each busbar is lifted into place separately from the front prior to attachment.

Busbars and accessories

Busbars KSFS 16183 CSS, KSFS 16151 CSS for 1600 A with an insulating section at the rear. Available in two lengths.



Connection washer, AB 2500 CSS

- For connection at the rear of the busbar.
- Fits busbars, KSFS 16183 CSS and KSFS 16151 CSS.

Busbar support, KSSTD 312/16

For wall mounting or in a frame. Can be mounted on a flat surface or between two opposite walls.

Middle support, MSBD 312/16

Used at the middle of the busbar system when the length of the busbars are longer than 1 meter.



A complete installation as shown in this figure consists of two busbar supports, a middle support, three busbars and three connection washers.

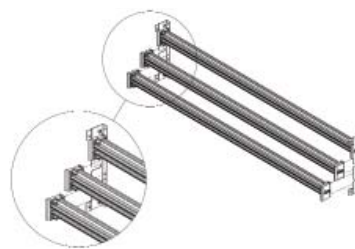
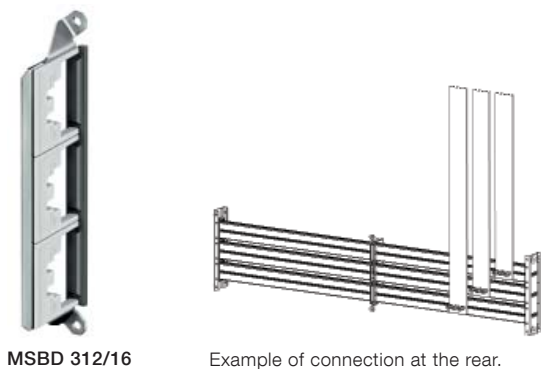

Quick installation, each busbar is lifted into place separately from the front prior to attachment.

Designation	ID No.	Degree of protection	Qty. modules	Dimensions				Weight
				Height	Length	Width	Depth	
				mm				kg/each
KSFS 16151 CSS	2CGX0 53320361	IP2X	151	70	1910	–	49	7.6
KSFS 16183 CSS	2CGX0 53320360	IP2X	183	70	2310	–	49	9.2
AB 2500 CSS	2CGX0 53320248	IPOX	7	60	–	80	56	0.31
KSSTD 312/16	2CGX0 53320240	–	3	330	–	30	82	0.4
MSBD 312/16	2CGX0 53320241	–	1	318	–	9.5	82	0.9

Busbar system

2500 A

2500 A busbar system for use in substations and low voltage switchgears. Adapted to Kabeldon IP-system.

The system has been tested for up to 65 kA short-circuit current.

Simple to connect power supply at rear with connection washer, AB 2500 CSS without modification to the busbar. Each busbar is lifted into place separately from the front prior to attachment.

Busbars and accessories

Busbars KSFS 16183 CSS, KSFS 16151 CSS for 1600 A with an insulating section at the rear. Available in two lengths.



KSST 325 CSS MSB 325 CSS KSST 325 CSS F

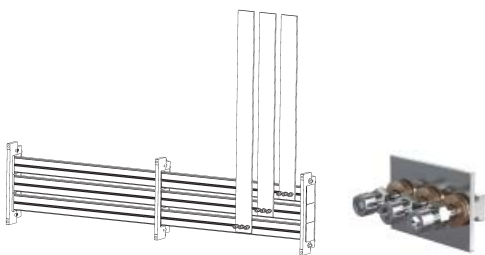

Example of connection at the rear. AB 2500 CSS

Connection washer, AB 2500 CSS

- For connection at the rear of the busbar.
- Fits busbars, KSFS 16183 CSS and KSFS 16151 CSS.

Busbar support, KSST 325 CSS

Reinforced busbar support for wall mounting, includes extra support for lateral movements.

Middle support, MSB 325 CSS

Used at the middle of the busbar system when the length of the busbars is longer than 1 meter.

Busbar support, KSST 325 CSS-F

Support for frame mounting. To be placed between two opposing walls, providing support for the busbars.



A complete installation as shown in this figure consists of two busbar supports, a middle support, three busbars and three connection washers.



KSFS 25150 CSS
KSFS 25182 CSS

Quick installation, each busbar is lifted into place separately from the front prior to attachment.

Designation	ID No.	Degree of protection	Qty. modules	Dimensions				Weight
				Height	Length	Width	Depth	
				mm				kg/each
KSFS 25150 CSS	2CGX0 53320354	IP2X	150	70	1910	–	49	8.8
KSFS 25182 CSS	2CGX0 53320353	IP2X	182	70	2310	–	49	10.6
AB 2500 CSS	2CGX0 53320248	IPOX	7	60	–	80	56	0.3
KSST 325 CSS	2CGX0 53320251	–	4	365	–	43	114	2.4
MSB 325 CSS	2CGX0 53320250	–	2	365	–	19.5	114	1.2
KSST 325 CSS-F	2CGX0 53320249	–	3	365	–	27	114	1.2

Busbar system

5-wire system

Kit for conversion to 5-wire system, TN-S or TN-C-S.

The kit includes a 400 A non-protected busbar.

- CXX-TNS fits in enclosures type CDC.
- SD XX-TNS fits in enclosures type SDC.

Note:

For additional information regarding upgrading kit for 1000 A or for use in enclosure type KSIK please contact your supplier.



Designation	ID No.	Fits enclosure	Qty modules	Rated current	Length	Weight
				A	mm	kg each
C20-TNS	2CGX0 53310613	CDC 20	20	400	333	0.6
C40-TNS	2CGX0 53310614	CDC 40	40	400	583	0.7
C60-TNS	2CGX0 53310615	CDC 60	60	400	833	0.9
SD 48-TNS	2CGX0 53320208	SDC 48	48	400	584	0.9
SD 73-TNS	2CGX0 53320219	SDC 73	73	400	898	1.0
SD 98-TNS	2CGX0 53320209	SDC 98	98	400	1212	1.2

General accessories for OEM



AB 800-53, AB 1200-53, AB 1200-70

For connection to the back of the busbar; fits 1000 A and 1600 A bar.

The kit includes:

- Plastic cover
- Thread insert, M12/M16 length 53 respectively 70mm
- Connecting washer
- Flat washer, Ø 36 mm
- Compression washer, Ø 29 mm
- Nut, M12

Note: The kit does not include the cable lug.



KBS 20

Kit for earthing busbars. Fits to busbar systems type KSFS 400 A -1600 A.

The ball headed bolt is tested for short-circuit current I_k 21.1 kA according to standards DIN 48088 and IEC 61230.

The kit consists of 3 ball headed bolts Ø 20 mm, connection unit for mounting to the busbars and a removable protective cover.



ADR M8/M10

For connection to the front of the busbar, with M8 or M10 thread.

ADR H12

For connection to the front of the busbar, with Ø12 hole. For busbars without protection against accidental contact.



RKMB 900

Tool kit for AB 800/1200.

The kit contains the necessary tools for:

- Stripping busbar insulation
- Drilling and tapping holes
- Fitting the thread insert

Designation	ID No.	Qty modules	Rated data	Diameter Ø	Qty per pack	Weight
				mm		kg/each
AB 800-53	2CGX0 53030500	-	500 V, 800 A	26	1	0.1
AB 1200-53	2CGX0 53030501	-	500 V, 1200 A	37	1	0.1
AB 1200-70	2CGX0 53030502	-	500 V, 1200 A	37	1	0.1
ADR M8*	2CGX0 63030239	2	500 V, 630 A	-	50	0.1
ADR M10*	2CGX0 63030240	2	500 V, 630 A	-	50	0.1
ADR H12	2CGX0 63030259	2	500 V, 630 A	-	50	0.1
RKMB 900	2CGX0 53030503	-	-	-	1	1.6
KBS 20	2CGX0 43311123	4	I_k 21.1 kA/1 s	-	1	1.1

* M8 and M10 screw thread respectively.

General accessories for OEM

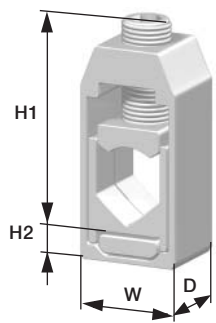

TC
Connecting clamps.

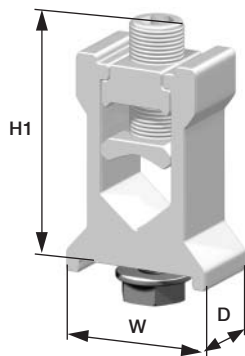

TC 300-40
Connecting clamps TC 300-40.

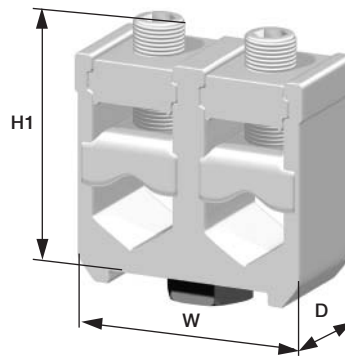

TCD
Connecting clamps TCD.

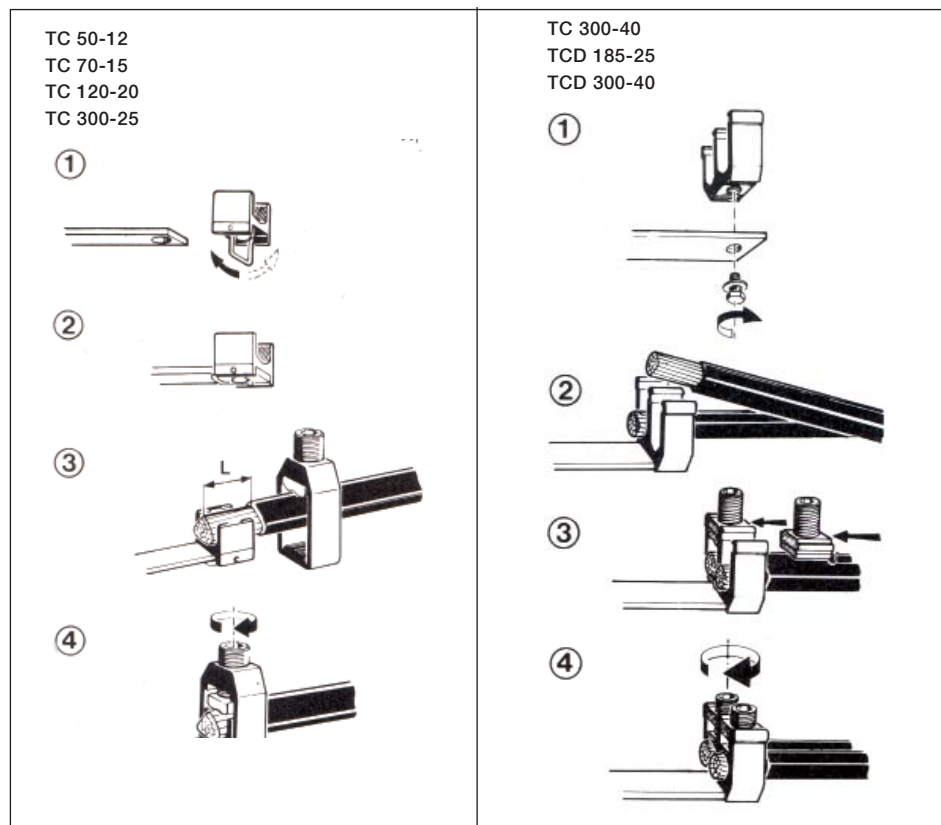

Designation	ID No.	Busbar		Conductor cross section Al/Cu	Connecting clamp				Weight
		Width	Thickness		W	H1	H2	D	
		mm		mm ²	mm				kg/unit
TC 50-12	2CGX0 63030202	12	1.5-3	6-50	21	27	5	16	0.02
TC 70-15	2CGX0 63030203	15	2-4	10-70	26	47	12	16	0.04
TC 120-20	2CGX0 63030204	20	3-5	35-120	32	60	12	22	0.08
TC 300-25	2CGX0 63030205	25	4-6	70-300	40	85	13	30	0.2
TC 300-40	2CGX0 63030209	40	4-6	95-300	47	84	-	30	0.2
TCD 185-25	2CGX0 63030206	25	4-6	2//50-185	48	75	-	30	0.2
TCD 300-40	2CGX0 63030207	40	4-6	2//95-300	65	84	-	30	0.3

General accessories



TFU 25

Single-phase power outlet for temporary connections, e.g. for a hand lamp or power drill. Mounts directly on the busbar. Conductor cross section, max. 35 mm² Al/Cu. Max. fuse 25 A.

Connectors for the PE and N conductors are also needed (see the page about connectors).



MCB 24

Norm casing for mounting on busbars including outside lying grey casings with smoke color transparent door.

Rated current max 63A

- N/PE busbars are included
- Degree of protection IP65
- Qty modules in norm casing is 2x12 M
- Mounted with anti condensation kit
- To be mounted with insulated tool VHB 68



UKRA 90

Universal clamp for fixing cables with Ø 20-90 mm, on mounting rails in a cabinet, for example.



KSJH 2

Norm casing for mounting on busbars including outside lying grey casings.

- Degree of protection IP2X
- Qty modules in norm casing is 2x4 M
- To be mounted with insulated tool VHB 68
- Accessories for mounting residual current device
- Width 6 M

Designation	ID No.	Rated data	Cable connection mm ²	Dimensions			Weight kg/each
				Height	Width	Depth	
				mm			
TFU 25	2CGX0 63140001	230 V, 25 A	1.5 -35 Al/Cu	84	30	185	0.3
MCB 24	2CGX0 63320001	-	-	310	275	165	4.4
KSJH 2	2CGX0 53190317	-	-	370	76	105	0.7

Designation	ID No.	Diameter Ø	Qty per pack	Weight
		mm		kg/each
UKRA 90	2GLX0 65300013	20-90	1	0.2

General accessories

GBLB 45, GBL 63



GBLB 45

Street lighting box for five-wire system (TN-S).

- Can be mounted on the PE/PEN-busbar or a mounting plate
- Contactor for 45 A
- Protection IP2X

Connectable cable cross section:

- Incoming cable to terminal block, max. 16 mm²
- Outgoing cable from contactor, max. 25 mm²
- Incoming/outgoing wiring for control circuits, max. 4 mm²

Maximum lighting loads switched by contactor (Data coming from the contactor manufacturer)

Lamp type	Lamp Wattage	Lamp rated current 230 V	Max Quantity	
			lamps/phase	
	W	A	GBLB 45	GBL 63
High-pressure sodium	150	1,8	17	23
Metall-halogen lamps	250	3,0	10	14
Uncompensated	400	4,4	7	9
	600	6,2	5	7
	1000	10,3	3	4
High-pressure sodium	150	1,0	20	50
Metall-halogen lamps	250	1,5	13	33
Compensated	400	2,5	8	20
	600	3,3	6	15
	1000	6,2	3	8
Mercury, high pressure	125	1,2	34	55
	250	2,2	18	29
Uncompensated	400	3,3	12	19
Mercury, high pressure	125	0,7	28	60
	250	1,3	15	30
Compensated	400	2,1	10	18



GBL 63

Street lighting box for five-wire system (TN-S).

- Can be mounted on mounting plate in the upper section of enclosures CDCM and SDCM
- Contactor for 63 A
- Degree of protection IP3X
- 7 M (125) free space for kWh metering, control etc

Connectable cable cross-section:

- Incoming/outgoing cable to terminal block, max. 16 mm²
- Incoming/outgoing wiring for control circuits, max. 4 mm²

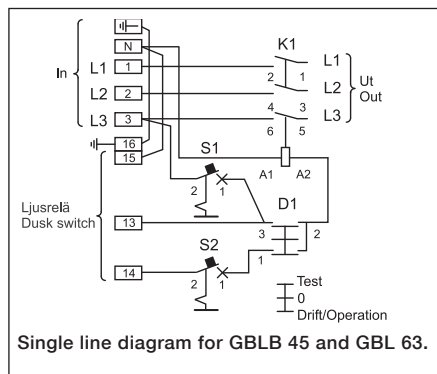

Designation	ID No.	Rated data	Cable connection	Dimensions			Weight
				Height	Width	Depth	
			mm ²	mm			kg/each
GBLB 45	2CGX0 63190371	400 V, 45 A	16/25/4 Cu	250	105	180	2.2
GBL 63	2CGX0 63190374	400 V, 63 A	4Cu/16 Al/Cu	382	250	132	4.8

General accessories

SCA, SVA



SCA

Surge current arrester kit. Heavy-duty protection needed when an overhead line or lightning-conductor is used.

The kit comprises:

- Three heavy duty arresters for TN-C (four-wire) system with bracket for mounting on the PEN bar
- The necessary flexible wires
- Connectors (AD 95 for phase connection, AD 70 for PEN connection).
- Installation instructions



SVA

Surge voltage arrester kit.

A medium-duty arrester for use with underground networks and where no lightning-conductors are used.

The kit comprises:

- Four medium-duty arresters for TN-S systems with attachment for mounting on the N bar
- The necessary flexible wires
- Connectors (AD 95 for phase connection, AD 70 for PE and N connection).
- Installation instructions

Can also be used in a TN-C system.

Choice of surge protection:

Choose SCA (heavy-duty protection)

- When the building has a lightning conductor.
- Electricity supply via overhead line.
- In rural areas with a high frequency of lightning strikes.
- Class: I/B

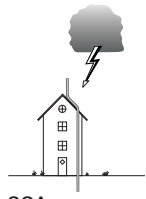

SCA
Lightning conductor



SCA
Overhead line

Choice of surge protection:

Choose SVA (medium-duty protection)

- With electricity supply via buried cable (at least 200 metres of cable to the overhead line network).
- Class: II/C



SVA
Buried cable > 200 m

Designation	ID No.	Rated data	Cable connection mm ²	Dimensions			Weight kg/each
				Height	Width	Depth	
SCA	2CGX0 53190270	230 V (L-N)	25	150	130	90	2.9
SVA	2CGX0 53310671	230 V (L-N)	25	90	90	90	1.9

General accessories



KSKP 25/50
Terminal block.



PSFS 5/17
Plate for sealing phase bar.

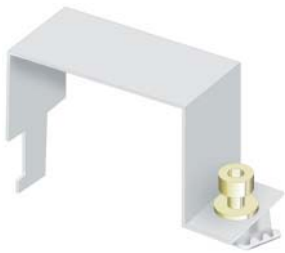

PBKP 25/50
Seal cover for KSKP 25/50.

Designation	ID No.	Qty. modules	Rated data	Cable connection	Width	Weight
				mm ²	mm	kg/each
KSKP 25	2CGX0 63130005	–	500 V, 63 A	1.5-25	56	0.2
KSKP 50	2CGX0 63130007	–	400 V, 160 A	6-50	73	0.3
PSFS 5	2CGX0 53050143	5	–	–	–	0.1
PSFS 17	2CGX0 53050144	17	–	–	–	0.1
PBKP 25	2CGX0 53050141	–	–	–	80	0.1
PBKP 50	2CGX0 53050142	–	–	–	96	0.1

Dimension drawings

All dimensions in mm

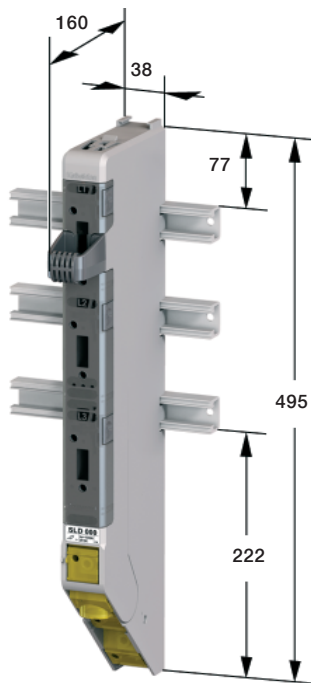

SLD 000

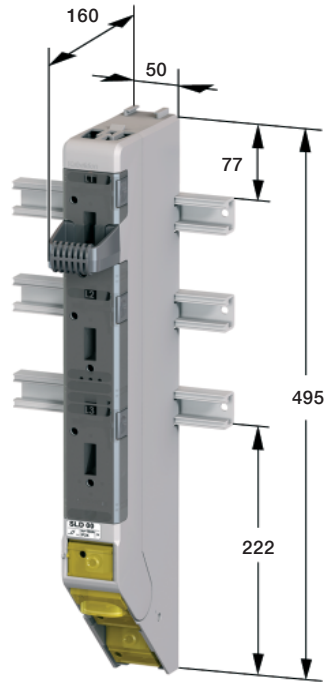

SLD 00

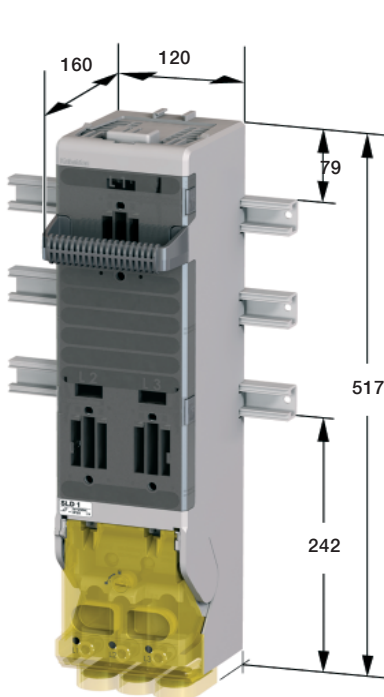

SLD 1

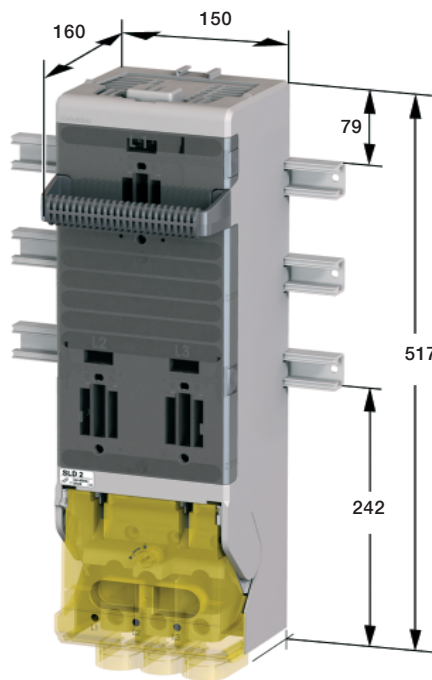

SLD 2

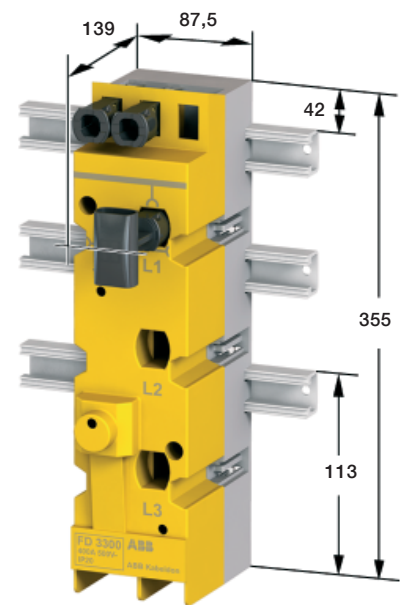

FD 3300

Dimension drawings

All dimensions in mm

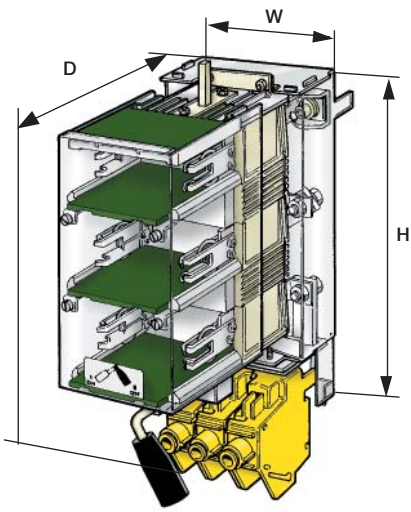

SEKO

Designation	H	W	D
SEKO 160	394	147	172

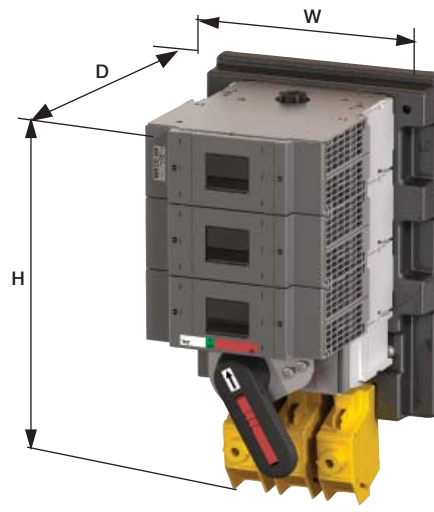

SEKOD

Designation	H	W	D
SEKOD 250	425	213	205
SEKOD 400	425	211	215

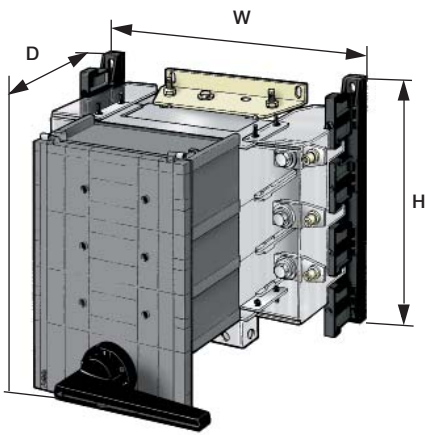

SLOB

Designation	H	W	D
SLOB 400	365	211	215
SLOB 630	384	357	260
SLOB 800	410	308	235

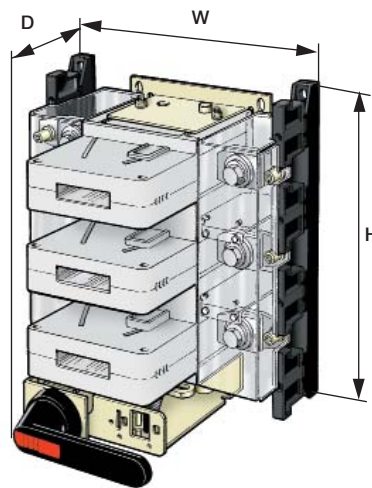

LBOC

Designation	H	W	D
LBOC 630	292	313	200
LBOC 800	292	280	180
LBOC 1600	363	420	220

Dimension drawings

All dimensions in mm

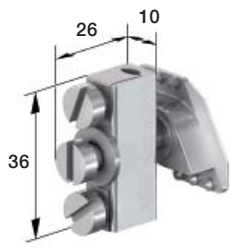

ADC 25

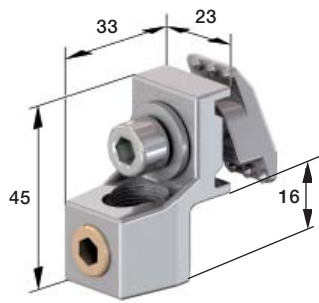

AD 70

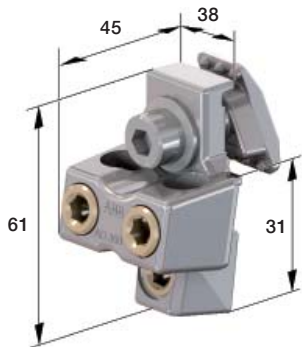

AD 350

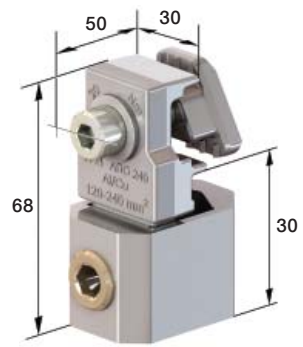

ADO 240

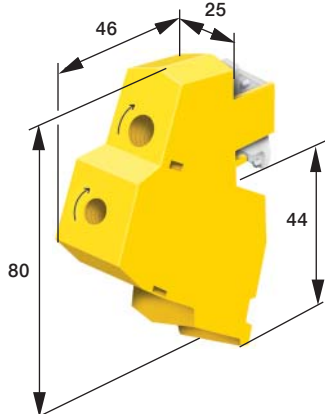

AD 95

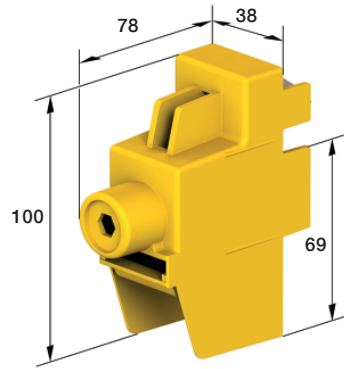

AD 2150

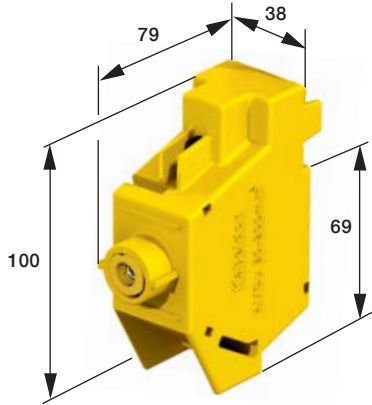

AD 300

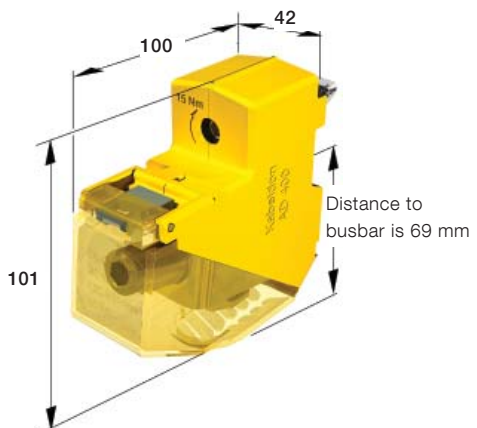

AD 400

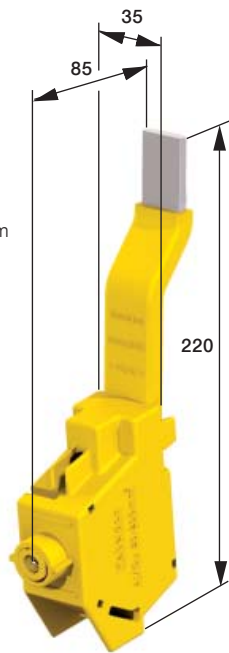

STM 400

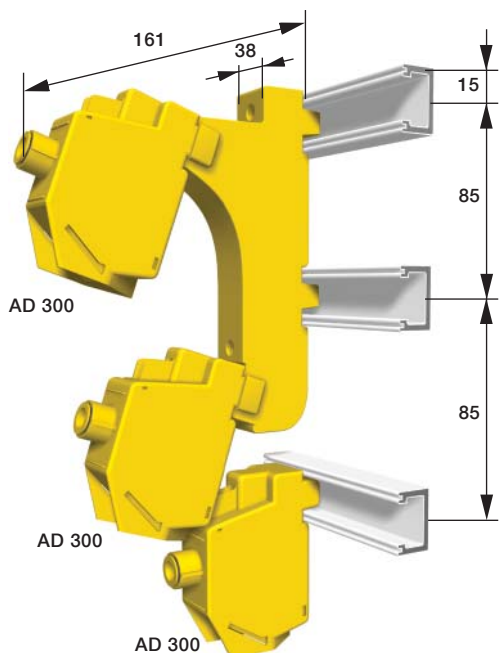

ADB 3M + 3 AD 300

Dimension drawings

Busbar supports and middle supports 400-1600 A

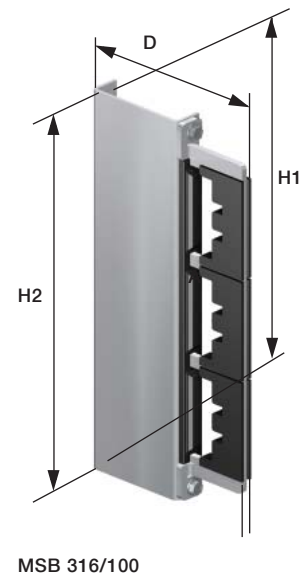
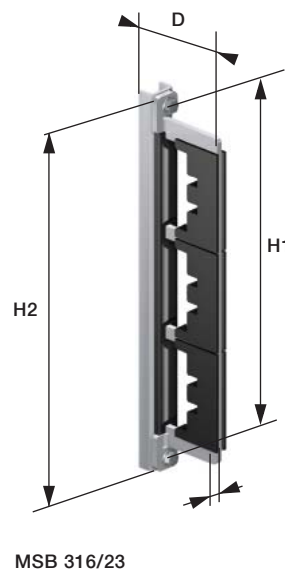
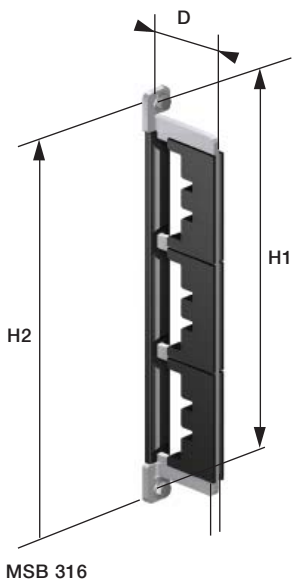
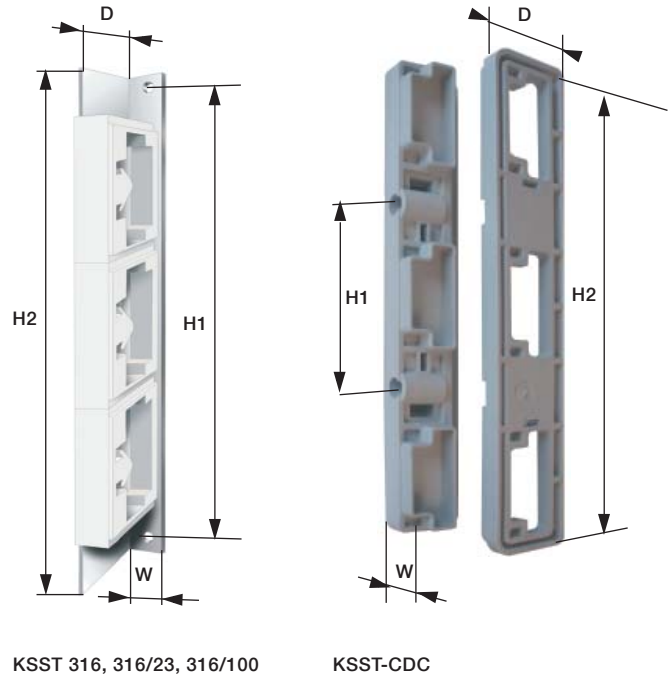
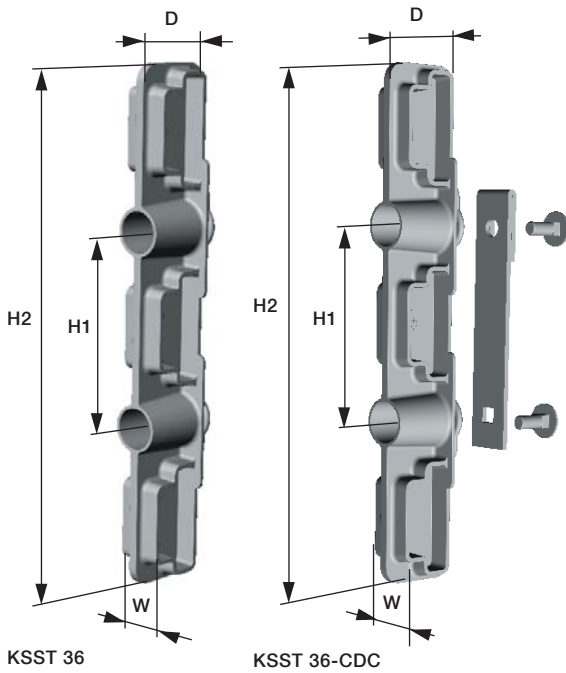

Designation	H1	H2	W	D
	mm			
KSST 36	85	226	20	39
KSST 36-CDC	85	226	20	39
KSST 316	300	320	20	46
KSST 316/23	300	320	20	60
KSST 316/100	300	320	39	136
KSST-CDC	85	237	28	47.5
MSB 316	300	318	10	62
MSB 316/23	300	318	10	76
MSB 316/100	300	318	10	152

Dimensions

Busbar supports and middle supports 1600 A and 2500 A

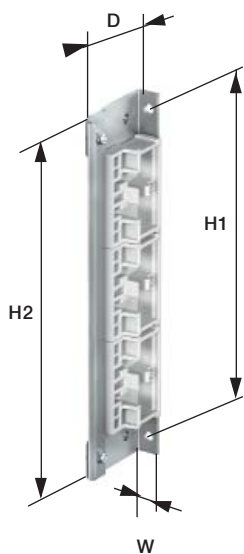

KSSTD 312/16

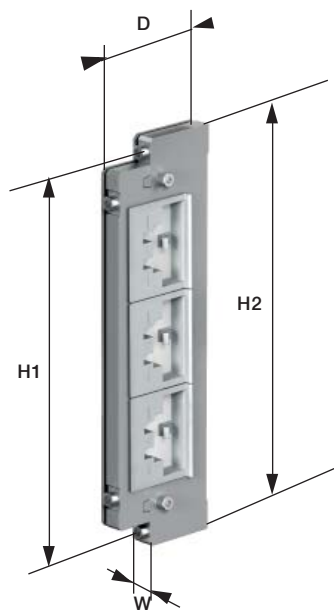

KSST 325 CSS

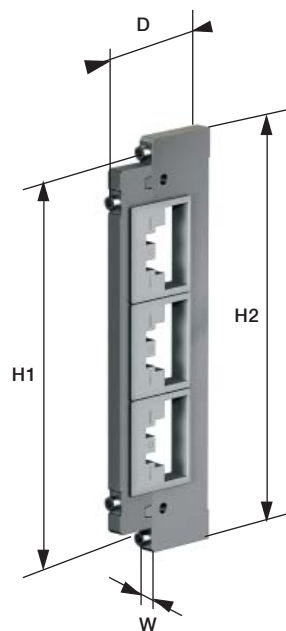

MSB 325 CSS

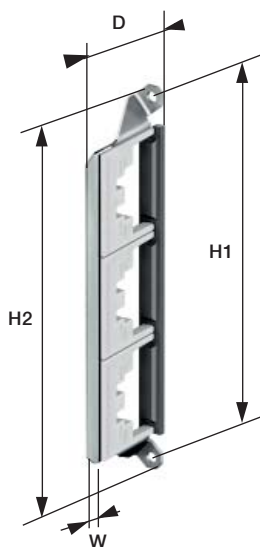

MSBD 312/16

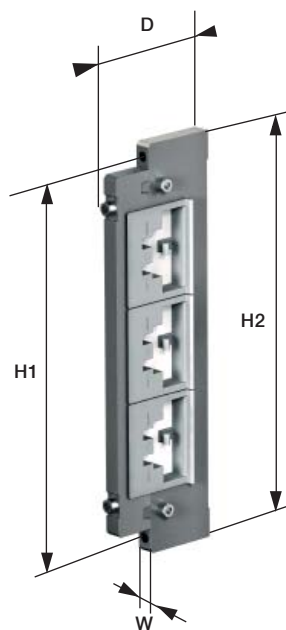

KSST 325 CSS F

Designation	H1	H2	W	D
	mm			
KSSTD 312/16	300	330	30	86
MSBD 312/16	300	318	9.5	88
KSST 325 CSS	340	365	43	114
MSB 325 CSS	340	365	19.5	114
KSST 325 CSS-F	340	365	27	114

Table of contents

Enclosures

	Page No.
Standards for enclosures	49
Hot-dip galvanized enclosures CDC	52
Enclosures for telecommunications and fibre-optic cables	54
Hot-dip galvanized enclosures SDC	56
Powder coated enclosures for indoor use KSIK	58
Hot-dip galvanized enclosures CDCM with upper section	60
Hot-dip galvanized enclosures SDCM with upper section	62
Pole mounted cable distribution cabinets CDCP	64
Hot-dip galvanized accessory cabinet CDCA	66
Metered public lighting pillars	68
Service distribution boards	69
5-wire system	71
Accessories for enclosures	72
Accessories for kWh metering	74
Locks and tools	77
Keys and tools	78
Examples of combinations of enclosures	79
Dimension drawings	80

Standards Enclosures

Enclosure

Enclosure series CDC and SDC are made of hot-dip galvanized sheet steel according to standards: ISO 1461, IEC 61439-1 and IEC 61439-5.

KSIIK enclosures are powder coated steel enclosures for indoor use in environment classed C₁ and C₂ to ISO 12944-2.

Protection

The degree of protection is IP34D, in accordance with the requirements of IEC 60529, unless otherwise stated under "Technical data".

Foundation

In the CDC range, the ground foundation is an integral part of the design. The length of the legs are individually adjustable and they can be angled out to avoid protruding building foundations. Separate foundations for ground, floor or wall mounting are available for the SDC range.

All below-ground parts have heavy-duty corrosion protection.

KSIIK enclosures are for wall mounting indoors only.

Excavation depth

To ensure an attractive and functional installation in the ground, we recommend excavating to a depth at which about 10 cm of the foundation is visible above the restored surface. A marking label indicates the ground level.

Special operating conditions

With this type of installation, consideration must be given to the risk of condensation, dust, vibration and impacts.

All enclosures except KSIIK have ventilation apertures between the cover plate and the door and between the door and the roof, both on the front and back of the enclosure.

The ability of the enclosure to withstand external blows and impacts has been checked by testing at -50° C in accordance with the requirements for use in an Arctic climate in IEC 61439-5.

Note:

To reduce the risk of condensation, we recommend filling the foundation with sand, leca and/or using a damp barrier.

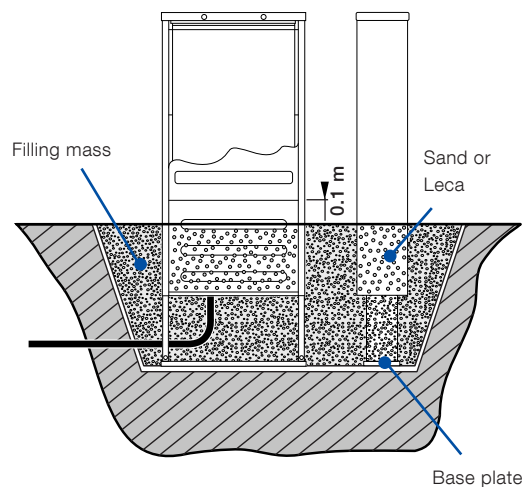

Standards Enclosures

Frost heave and CDC

A sliding bar system in the enclosures type CDC reduces the problems that may arise in connection with frost heave.



External fixing points

The sides of all enclosures except the indoor enclosure KSIK are fitted with rivet-nuts to attach marking poles, other enclosures, boxes, etc.

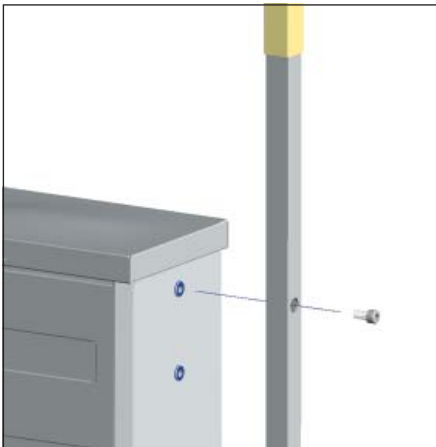

Openings for temporary outlets

Both sides of CDC and SDC enclosures have an opening for a temporary power outlet or to make protected connections between two enclosures. The openings are fitted with a revolving seal with a choice of five openings, the largest of which is Ø 60 mm.

Where more SDC enclosures are to be combined, special sides are available.

For further information contact your supplier or us.

On KSIK, there are two covered flange openings, size FL 33 in each side panel.



Marking

A sliding bar system in the enclosures type CDC reduces the problems that may arise in connection



with frost heave.

Locks

The enclosures have different locks depending on their field of application, see the product pages.



Standards Enclosures

Modular system

All parts that can be connected to the busbar system have modular dimensions (one module M = 12.5 mm). This makes it easy to calculate the space required by a particular distribution board and then to choose a suitable enclosure.



Type designation

The following list mentions some typical applications for Kabeldon IP-system:

CDC xyz (CDC = enclosure type. This may be replaced by SDC or KSIK.)

x = rated current:

0 = cabinet without busbar system

4 = busbar system with rated current 400 A

6 = busbar system with rated current 630 A

yz = number of modules available on the busbar (20, 40, 48 etc.)

Enclosures with upper section

As standard, the enclosure comes with a busbar system in the lower section, but with no equipment in the upper section (the meter space).

For the upper section there are meter panels, MPF 25 B or MPF 63 B, to mount the meters on.

The meter panel fixes on to a mounted fixing bar, making fitting simple and flexible. Meter panels have a width of 220 mm. The meter panels come with a suitable intermediate terminal block.



Enclosures with upper section, CDCM and SDCM.



Meter panel MPF 25 B/MPF 63 B.

Entries to the upper section

Between the upper and lower sections there are openings which are partly covered by a plastic plug with "breakouts". The largest opening, \varnothing 50 mm, can take seven 50 mm² cables.

Locks

The upper section of the enclosure is fitted with a lock which takes a standard triangular-section key, so that the customer and the electricity supplier can open that section. For the lower section, see the product pages.

Hot-dip galvanized enclosures

CDC

CDC is supplied with a busbar system or with a mounting plate.

- Tested to the requirements of IEC 61439-5. Passes arctic climate tests.
- Integral foundation.
- Adjustable foundation prepared for fitting of a baseplate.
- The foundation is prepared for fixing conduits when installing heating cables.
- The sides have a bracket to attach a snow marking pole or an accessory cabinet.
- On the inside of the door there is a card holder.
- The embossed areas on the door are compatible with most common marking systems.
- Degree of protection IP34D.



CDC is supplied with a busbar system or with a perforated mounting plate.

Designation	ID No.	Equipment included	Qty modules	Rated current	Dimensions			Weight
					Height	Width	Depth	
					A	mm		kg each
CDC 020	2CGX0 63300396	mounting plate	-	-	1200	350	220	36
CDC 040	2CGX0 63300397	mounting plate	-	-	1200	600	220	50
CDC 060	2CGX0 63300398	mounting plate	-	-	1200	850	220	64
CDC 420	2CGX0 63300390	busbar system	20	400	1200	350	220	34
CDC 440	2CGX0 63300391	busbar system	40	400	1200	600	220	47
CDC 460	2CGX0 63300392	busbar system	60	400	1200	850	220	59
CDC 640	2CGX0 63300394	busbar system	40	630	1200	600	220	48
CDC 660	2CGX0 63300395	busbar system	60	630	1200	850	220	60

Contents	Enclosure with busbar system	Enclosure without busbar system
	CDC 420-660	CDC 020-060
Mounting plate	No	Yes
Busbar system	400 A, 630 A	No
PEN bar movable to three positions	400 A	No
Anchor bar adjustable to two positions	Yes	Yes
Foundation leg length individually adjustable	Yes	Yes
Outlet opening with revolving seal Ø 15-60 mm	Yes	Yes
Key shape for lock	SE	Triangular
Heavy-current warning symbol on outside of door	Yes	No

To be ordered separately:



C20-BP, C40-BP, C60-BP
Base plate.



FV, FVD
Wall spacer.

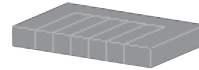

C20-DB, C40-DB, C60-DB
Damp barrier fits all CDC enclosures.



KSPS 6
Marking pole.



CDC-CLA
Mounting kit for cylinder lock.



TN-S system
Five-wire kit.



BERG 250
Rock hold for cable distribution cabinets type CDC when installed in rocky ground.

Hot-dip galvanized enclosures

Telecommunications and fibre-optic cables

Hot-dip galvanized enclosures for outdoor applications or in environments where long life and durability are essential.

- Tested to the requirements of IEC 61439-5. Passes arctic climate tests.
- Integral foundation (CDC).
- The sides have a bracket to mark it as an obstacle or for an accessory cabinet.
- On the inside of the door there is a holder for a cable distribution cabinet card. The outside is compatible with the most common marking systems.
- Degree of protection IP34D.

Note:

Under an agreement with the telecoms sector, enclosures for telecommunications must not be fitted with a triangular lock. Order these enclosures with CDC-LTC or SDC-LTC.



Enclosure with cable coiler for fibre-optic cable.



A cable distribution cabinet for electric power combined with an enclosure including a fiberduct module.

Designation	ID No.	Mounting plate		Dimensions Installations depth	Locks	Weight
		Height	Width			
		mm				mm
CDC 020	2CGX0 63300396	700	300	198	Triangular	36
CDC 040	2CGX0 63300397	700	550	198	Triangular	50
CDC 060	2CGX0 63300398	700	800	198	Triangular	64
SDC 048	2CGX0 63300433	770	584	275	Triangular	46
SDC 073	2CGX0 63300551	770	898	275	Triangular	58

To be ordered separately



CC 20
Cable coiler for about 25 metres of 13 mm OD cable.

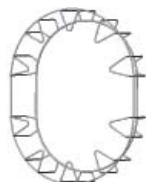

CC 30
Cable coiler for about 30 metres of 16 mm OD cable.



EB 435
Earth block for 4 mm² or 35 mm².



KSMP-S 48/73
Steel mounting plate for SDC. Perforated with 38 mm hole pitch (Ø 3.5 mm).



BK-E
Bracket for fibre-optic cable junction box from Ericsson.



BK-N
Bracket for fibre-optic cable junction box from Nexans.

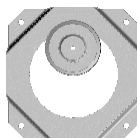

BK-T
Bracket for fibre-optic cable junction box from Tykoflex.



FDM-K
Mounting kit developed for mounting fibre duct module FDM (Ericsson Ribbonet) on Kabeldon IP-system.



FDM
The fibre duct module is used when jointing ducts for optical fibre.

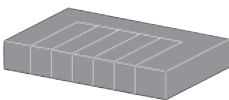

C20-DB C40-DB, C60-DB
Damp barrier fits all enclosures type CDC.



CDC-LTC
Lock for CDC enclosures with telecom equipment.



SDC-LTC
Lock for SDC enclosures with telecom equipment.



NK-TC
Key to lock CDC-LTC and SDC-LTC.



BERG 250
Rock hold for cable distribution cabinets type CDC when installed in rocky ground.

Designation	ID No.	Dimensions			Weight kg each
		Height	Width	Depth	
		mm			
CC 20	2CGX0 53310695	415	215	153	0.6
CC 30	2CGX0 53310689	740	550	155	2.5
EB 435	2CGX0 43311031	135	35	35	0.1
KSMP-S 48	2CGX0 53190332	770	584	19	5.0
KSMP-S 73	2CGX0 53190335	770	898	19	8.0
BK-E	2CGX0 53310691	167	167	10	0.4
BK-N	2CGX0 53310694	295	198	10	0.6
BK-T	2CGX0 53310690	225	160	10	0.3
FDM-K	2CGX0 53310704	-	-	-	0.1
FDM	2CMA1 31600R1000	506	135	93	1.0
C20-DB	2CGX0 53310696	50	350	215	0.2
C40-DB	2CGX0 53310697	50	600	215	0.3
C60-DB	2CGX0 53310698	50	850	215	0.4
CDC-LTC	2CGX0 43311040	-	-	-	0.1
SDC-LTC	2CGX0 43310599	-	-	-	0.1
NK-TC	2CGX0 63190373	113	30	26	0.1
BERG 250	2CGX0 63300649	370	130	30	1.9

Hot-dip galvanized enclosures

SDC

SDC is supplied with or without a busbar system. The SDC range is suitable for electrical distribution boards such as general distributions boards, power distribution boards in industry, construction site distributions boards or for temporary power distribution.

The distribution boards are built to customer requirements, with direct metering or current transformer metering.

- Tested to the requirements of IEC 61439-5. Passes arctic climate tests.
- Side-hung doors, opening angle >180°.
- The sides have a bracket to attach a snow marking pole or an accessory cabinet, for example.
- The depth, 312 mm, allows installation of all switching devices with independent manual operation.
- The LD version is available with a depth of 242 mm.
- Degree of protection IP34D.

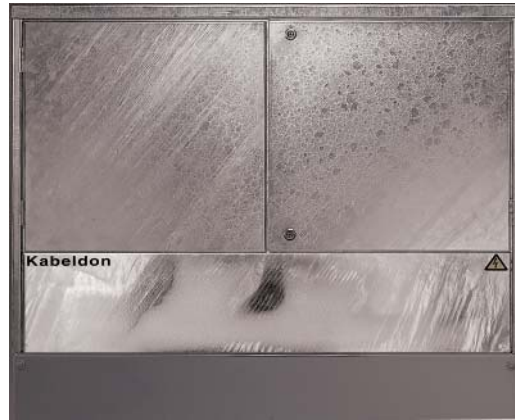

Note:

- For quick, simple planning, download your copy of the free Connect IT program.
- Many different configurations of the SDC range can be ordered. Please contact your supplier for further information.

Designation	ID No.	Equipment included	Qty modules	Rated current	Dimensions			Weight
					Height	Width	Depth	
					A	mm		kg each
SDC 048	2CGX0 63300433	–	–	–	895	682	312	46
SDC 073	2CGX0 63300551	–	–	–	895	996	312	58
SDC 098	2CGX0 63300437	–	–	–	895	1310	312	70
SDC 448	2CGX0 63300431	busbar system	48	400	895	682	312	48
SDC 473	2CGX0 63300552	busbar system	73	400	895	996	312	60
SDC 648	2CGX0 63300432	busbar system	48	630	895	682	312	49
SDC 673	2CGX0 63300553	busbar system	73	630	895	996	312	62
SDC 698	2CGX0 63300434	busbar system	98	630	895	1310	312	75
SDC 673 LD	2CGX0 63300635	busbar system	73	630	895	996	242	59
SDC 698 LD	2CGX0 63300571	busbar system	98	630	895	1310	242	73

Contents	Enclosure with busbar system		Enclosure without busbar system
	SDC 448-698	SDC 673-698 LD	SDC 048-098
Mounting plate	No		No
Busbar system	400 A, 630 A		No
PEN bar	400 A		No
Foundation	No (order separately)		No (order separately)
Outlet opening with revolving seal Ø 15-60 mm	Yes		Yes
Key shape for lock, SDC 448-698	Triangular		Triangular
Key shape for lock, SDC 673-698 LD	SE (EBR)		-
Heavy-current warning symbol on outside of door	Yes		No

To be ordered separately:



GOLV-S 48-98
Floor foundation.



BPF-S 48-98
Baseplate.



SLUS 48-98
Lower door with outlet opening.



KSMP-S 48-98
Mounting plate.



MARK-S 48-98
Ground foundation.



FVD, VF 100
Wall spacer.



VF-S 30
Wall bracket.



KSPS 6
Marking pole.



TN-S system
Five-wire kit.

Powder coated enclosures for indoor use

KSIK

KSIK enclosures are designed for indoor use, environment classes C₁ and C₂*. An enclosure with a high degree of protection, well suited for installations in industry and in buildings.

The enclosure is developed for distribution boards and therefore has special openings in its sides to allow busbar systems to pass through where more than one enclosure is combined.

- Supplied complete with wall brackets and mounting plate.
- Powder coated.
- Side-hung doors.
- Removable mounting plate.
- Split baseplate.
- Degree of protection IP34D.

Note:

Busbar systems for 400 A-1600 A on request.



Designation	ID No.	Qty flange openings FL 21 in the base plate	Qty modules	Dimensions			Weight kg each
				Height	Width	Depth	
KSIK 043	2CGX0 63300411	4	43	900	655	325	42
KSIK 063	2CGX0 63300412	6	63	900	895	325	57
KSIK 098	2CGX0 63300413	10	98	900	1350	325	75

*To ISO 12944-2

C₁: Heated, dry room

C₂: Small amounts of humidity may occur.

Contents	Enclosure KSIK
Mounting plate	Yes
Key shape for lock	DIN 3
Two covered flange openings, size FL 33 in each side panel.	Yes
Baseplate with FL 21 flange openings	Yes
Split baseplate	Yes
Busbar system	On request

To be ordered separately:



TN-S system
Five-wire kit.



KSFS 400 A-1600 A
Busbar system.

Hot-dip galvanized enclosures with upper section CDCM

The CDCM cabinets are the same as CDC but are fitted with an upper section which can be locked separately. CDCM 020 and CDCM 040 comes with a mounting plate instead of a busbar system in the lower section.

The CDCM range is suitable for construction of electrical distribution boards such as general distribution boards, power distribution boards in industry, construction site distribution boards etc., where there is a need to integrate the equipment with kWh metering. The distribution boards are built to customer requirements, with direct metering or current transformer metering.

- Tested to the requirements of IEC 61439-5. Passes arctic climate tests.
- Integral foundation.
- The sides have a bracket to attach a snow marking pole or an accessory cabinet.
- On the inside of the door there is a holder for a cable distribution cabinet card.
- The embossed areas on the door are compatible with most common marking systems.
- The upper section is fitted with a fixing bar for meter panel MPF 25 B/MPF 63 B or with mounting plate MPP 20.
- Removable mounting plate.
- Split baseplate.
- Degree of protection IP34D.



Designation	ID No.	Equipment included	Space for Qty Meter panels MPF 25/MPF 63	Qty modules	Rated current	Dimensions			Weight
						Height	Width	Depth	
						mm			
CDCM 020	2CGX0 63300530	Mounting plate	1	-	-	1800	350	220	49
CDCM 040	2CGX0 63300608	Mounting plate	2	-	-	1800	600	220	68
CDCM 420	2CGX0 63300430	Busbar system	1	20	400	1800	350	220	47
CDCM 440	2CGX0 63300609	Busbar system	2	40	400	1800	600	220	65
CDCM 640	2CGX0 63300610	Busbar system	2	40	630	1800	600	220	66

Contents	Enclosure with busbar system	Enclosure without busbar system
	CDC 420-640	CDC 020-040
Mounting plate, lower section	No	Yes
Busbar system	400 A, 630 A	No
PEN bar movable to three positions	400 A	No
Anchor bar adjustable to two positions	Yes	Yes
Foundation leg length individually adjustable	Yes	Yes
Outlet opening with revolving seal Ø 15-60 mm	Yes	Yes
50 mm diameter openings between the sections fitted with plastic covers	Yes	Yes
Key shape for lock, lower/upper section	SE/customer	SE/customer
Heavy-current warning symbol on outside of door	Yes	No

Low-profile meter cable enclosure

Can be built with the following standard products:

	Designation	ID No.
1 cabinet	CDC 020	2CGX0 63300396
1 meter panel	MPF 63 B	2CGX0 53310738
1 PEN bar	KSNS 417	2CGX0 43320059
1 upgrade kit	CKM	2CGX0 53390034
1 customer lock	CDC-LA	2CGX0 43310740
Where applicable, terminal block	KSKP 25	2CGX0 63130005
	KSKP 50	2CGX0 63130007
For supply cable and seal cover	PBKP 25	2CGX0 53050141
	PBKP 50	2CGX0 53050142

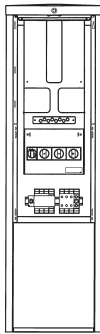

With this design, the kWh meter is 0.5 metres above the ground.
Requirement according to SS 437 01 40 is 0,9 m (h2).

To be ordered separately:



GOLV-S 48-98
Floor foundation.



MPP 20
Mounting plate.



MPF 25 B/MPF 63 B
Meter panel.

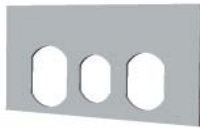

CDC-CLA
Mounting kit for cylinder lock.



FV, FVD
Wall spacer.



BERG 250
Rock hold for cable distribution cabinets type CDC when installed in rocky ground.



TN-S system
Five-wire kit.



KSPS 6
Marking pole.

Hot-dip galvanized enclosures with upper section SDCM

The SDCM cabinets are the same as SDC but are fitted with an upper section which can be locked separately.

The upper section can be used to house kWh meters or fitted with a mounting plate for various purposes.

The SDCM range is suitable for the construction of electrical distribution boards such as general distribution boards, power distribution boards in industry, construction site distribution boards etc., where there is a need to integrate the equipment with kWh metering.

- Tested to the requirements of IEC 61439-5. Passes arctic climate tests.
- Side-hung doors, opening angle >180°.
- The sides have a bracket to attach a snow marking pole or an accessory cabinet.
- The depth allows installation of all switching devices with independent manual operation.
- Degree of protection IP34D.

Note:

- For quick, simple planning, order your copy of the free Connect IT program.
- Many different configurations of the SDC range can be ordered. Please contact your supplier for further information.



Enclosure with distribution board and kWh metering installed.

Designation	ID No.	Equipment included	Space for Qty Meter panels MPF 25/MPF 63	Qty modules	Rated current	Dimensions			Weight kg each
						Height	Width	Depth	
						mm			
SDCM 048	2CGX0 63300443	-	3	-	-	1530	682	312	72
SDCM 073	2CGX0 63300561	-	4	-	-	1530	996	312	92
SDCM 098	2CGX0 63300444	-	5	-	-	1530	1310	312	111
SDCM 448	2CGX0 63300435	Busbar system	3	48	400	1530	682	312	74
SDCM 473	2CGX0 63300562	Busbar system	4	73	400	1530	996	312	94
SDCM 648	2CGX0 63300436	Busbar system	3	48	630	1530	682	312	75
SDCM 673	2CGX0 63300563	Busbar system	4	73	630	1530	996	312	96
SDCM 698	2CGX0 63300438	Busbar system	5	98	630	1530	1310	312	116

Contents	Enclosure with busbar system	Enclosure without busbar system
	SDCM 448-698	SDCM 048-098
Mounting plate, lower section	No	No (order separately)
Busbar system	400 A, 630 A	No
PEN bar	400 A	No
Foundation	No (order separately)	No (order separately)
Outlet opening with revolving seal Ø 15-60 mm	Yes	Yes
50 mm diameter openings between the sections fitted with plastic covers	Yes	Yes
Key shape for lock, lower/upper section	Triangular/customer	Triangular/customer
Heavy-current warning symbol on outside of the door	Yes	No

To be ordered separately:



GOLV-S 48-98
Floor foundation.



BPF-S 48-98
Baseplate.



SLUS 48-98
Lower door with outlet opening.



KSPS 6
Marking pole.



MARK-S 48-98
Ground foundation.



FVD, VF 100
Wall spacer.



VF-S 30
Wall bracket.



TN-S system
Five-wire kit.



MPF 25 B /63 B
Meter panel.



MPP-S 48-73, KSMP-S 48-98, MPT-S 48
Mounting plate.

Pole-mounted cable distribution cabinets

CDCP

Pole-mounted cable distribution cabinets are supplied with integral pole bracket, busbar system or mounting plate and as well as a cable duct to the ground.

- On the back there is an opening for an earthing line and an opening for temporary connections.
- Breakouts for up to seven cable channels.
- Degree of protection IP34D.



Breakouts for cable channels on the back of the pole-mounted cabinet.

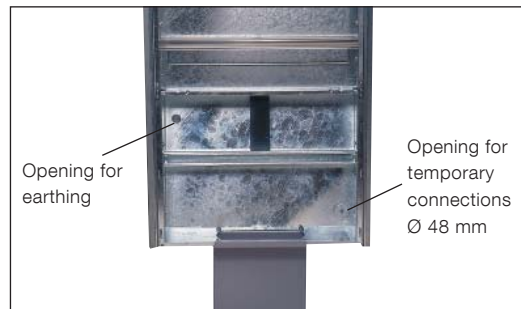

A cable duct to the ground is supplied with the cabinet.

Designation	ID No.	Equipment included	Qty modules	Rated current	Qty cable ducts	Dimensions			Weight
						Height	Width	Depth	
						mm			kg each
CDCP 020	2CGX0 63300621	Mounting plate	20	-	0 - 3	1200	350	382	45
CDCP 040	2CGX0 63300622	Mounting plate	40	-	0 - 7	1200	600	382	61
CDCP 420	2CGX0 63300428	Busbar system	20	400	0 - 3	1200	350	382	43
CDCP 440	2CGX0 63300429	Busbar system	40	400	0 - 7	1200	600	382	58

Contents	Enclosure with busbar system	Enclosure without busbar system
	CDCP 420, 440	CDCP 020, 040
Cable duct to the ground	Yes	Yes
Busbar system	400 A	No
PEN bar	400 A	No
Anchor bar	Yes	Yes
Key shape for lock	SE	Triangular
Heavy-current warning symbol on outside of door	Yes	No

To be ordered separately:



KKCS
Joining piece for cable channel made of non-corrosive and non-magnetic material.



KHB 3
Holder for 1 to 3 cable channels.



KHB 5
Holder for 3 to 5 cable channels.



KHB 7
Holder for 5 to 7 cable channels.



KKS
Extra support for cable channel.



CDCP-TP
Baseplate for sealing the opening at the bottom.



KKC 5
Cable channel 2 x 2.4 m with joining piece KKCS.

Designation	ID No.	Qty per pack	Dimensions			Weight
			Height	Width	Depth	
			mm			kg each
KKCS	2CGX0 53190244	1	100	57	61	0.2
KHB 3	2CGX0 63190245	1	105	184	250	0.3
KHB 5	2CGX0 63190246	1	105	294	250	0.4
KHB 7	2CGX0 63190279	1	105	404	250	0.6
KKC 5	2CGX0 53190243	1 kit	2400	55	55	3.2
KKS	2CGX0 63190286	1	30	250	190	0.4
CDCP-TP	2CGX0 53310728	1	16	260	191	0.6

Hot-dip galvanized accessory cabinet CDCA

Accessory cabinet for mounting on another enclosure.
The cabinet comes with a mounting plate.

- There are outlet openings in the sides. The opening on the right-hand side has a revolving seal with a choice of five openings. The seal can be moved to the left-hand side.
- The bottom of the cabinet has an opening with integral strain relief for temporarily connected cables. When not in use, the opening is blanked off with the cover supplied.
- Inserts for temporary power outlets KSMU 16/32/63 can be installed in the cabinet, as well as meter panel MPF 25 B/MPF 63 B. Where meter panel MPF 25 B/MPF 63 B is installed, upgrade kit CKM is required.



CDCA mounted on the right side of CDC 420.



The openings on the sides of the cabinet is used for temporary power outlets, etc.

Designation	ID No.	Dimensions			Weight
		Height	Width	Depth	
		mm			kg each
CDCA	2CGX0 63300451	730	280	218	14.5

Contents	Accessory cabinet
	CDCA
Mounting plate	Yes
Outlet opening with revolving seal Ø 15-60 mm	Yes
Opening at the bottom with integral strain relief for temporarily connected cables	Yes

To be ordered separately:



KSMUB 16/32

1x16 + 2x10 A or 1x32 + 2x10A with residual current device, miniature circuit-breaker and space for a kWh meter. Strength of short circuit 6 kA in combination with equipment max 63 A.



CKM

Kit for installing meter panel MPF 25/63.

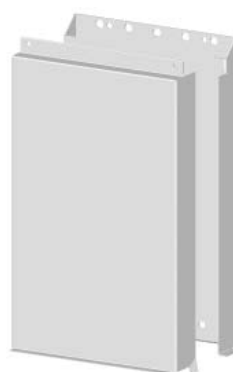

CDCA-CD

Cable protection duct for fibre optic cables, for example.

- Max cable diameter 25 mm inside cabinet.
- Max. diameter for optical fibre pipes is 45 mm.
- Degree of protection IP34D.



MPF 25 B/MPF 63 B

Meter panel for 25 A or 63 A.

Designation	ID No.	Cable connection	Outlet	Dimensions			Weight
				Height	Width	Depth	
				mm ²	mm		
KSMUB 16	2CGX0 63300611	6	1x16 A + 2x10 A	711	222	191	5.5
KSMUB 32	2CGX0 63300612	6	1x32 A + 2x10 A	711	222	191	5.5
CKM	2CGX0 53390034	-	-	-	-	-	0.02
MPF 25 B	2CGX0 53310737	-	-	570	220	115	5.0
MPF 63 B	2CGX0 53310738	-	-	570	220	115	5.0
CDCA-CD	2CGX0 53310705	-	-	380	240	66	2.3

Metered public lighting pillars

GBC 45-2, GBC 63-3

Public lighting pillars GBC 45-2, 45 A,
2 groups contain:

Qty	Designation	Description
1	CDCM 420	Enclosure
1	MPF 63 B	Meter panel
1	GBLB 45	Street lighting box
1	PBKP 50	Seal cover
3	AD 95	Insulated connector
2	SLD 000	Fuse-switch disconnecter
2	ADC 25	Non-insulated connector

The public lighting pillar is extendable to 3 groups.

The public lighting pillar is extendable to 3
groups.

Qty	Designation	Description
1	CDCM 440	Enclosure
1	MPF 63 B	Meter panel
1	MPP 20	Mounting plate steel
1	GBL 63	Street lighting box
1	PBKP 50	Seal cover
3	AD 95	Insulated connector
3	SLD 000	Fuse-switch disconnecter
3	AD 350	Non-insulated connector

The public lighting pillar is extendable to 10 groups.



GBC 45-2



GBC 63-3

Options and accessories

Material when several outgoing groups:



SLD 000

Fuse-switch disconnecter. Fuse NH 000 or C00. Degree of protection IP2X.



AD 350

Non-insulated connector for connecting three separate conductors, each max 50 mm² Al/Cu. May only be used with non-protected busbars.



ADC 25

Non-insulated connector. May only be used with non-protected busbars.

Designation	ID No.	Qty. modules	Rated data	Dimensions			Weight
				Height	Width	Depth	
				mm			kg each
GBC 45-2	2CGX0 63300632	20	400 V, 45 A	1800	350	220	58
GBC 63-3	2CGX0 63300633	40	400 V, 63 A	1800	600	220	81
SLD 000	2CGX0 63050106	3	400 V, 100 A	495	38	160	1.7
AD 350	2CGX0 63030262	–	400 A	61	38	45	0.2
ADC 25	2CGX0 63030233	–	63 A	36	10	26	0.1

Service distribution board

Direct kWh metering

Service distribution boards for direct kWh metering type CDCS 2520 for 25 A and CDCS 6320 for 63 A complete with all essential components for connecting the service cable and also an outgoing cable.

In these distribution boards, space for maximum six outgoing groups type SLD 000 is available.

- The enclosures are tested according to IEC 61439-5 and fulfill the requirements for use in arctic climate.
- Degree of protection, enclosures, IP34D.
- The foundation is integrated in the enclosure both for putting up on the floor indoors, and in the ground for installation outdoors.
- Customer lock (triangular) to upper section, DIN 3 lock for lower section and key to respective lock are included.
- Degree of protection, switching devices, IP 2X according to IEC 60529.



CDCS 2520
CDCS 6320

Designation	ID No.	Switch-off-power Rated current	Max outgoing groups	Free space on the busbar	Weight
		A		M*	kg each
CDCS 2520	2CGX0 63301145	25	6	20	55
CDCS 6320	2CGX0 63301146	63	6	20	55

Options and accessories

Material when several outgoing groups:



SLD 000
Fuse-switch disconnectors.
Degree of protection, IP2X.



AD 70
Non-insulated connector.



AD 95
insulated connector.

Options and accessories	Rated current	Designation	ID No.	Cable connection Al/Cu	Width	Weight
	A			mm ²	M*	kg each
Outgoing groups	100	SLD 000 (C00)	2CGX0 63050106	2.5-95	3	1.7
Connection to phase busbar	200	AD 95	2CGX0 79000011	6-95	2	0.1
PE/N clamp	-	AD 70	2CGX0 63030038	6-95	-	0.1

* One module M = 12.5 mm.

Service distribution board

Transformer metering

Four types of service distribution boards for kWh metering 160 A or 250 A, complete with all essential components for connecting the service cable, mounting current transformer, terminal blocks and meter.

Space for outgoing groups varies from 5 to maximally 14 depending to the size of the chosen service distribution board.

- Enclosures are tested according to IEC 61439-5 and fulfill the requirements for use in arctic climate.
- Degree of protection, enclosures, IP34D.
- The foundation of CDCS 16015 is integrated in the enclosure both for putting up on the floor indoors, and in the ground for installation outdoors.
- For SDCS the choice is dependent to putting up indoors on the floor or fixed on the wall; or also installation outdoors in the ground, please see "Accessories for enclosures".
- Customer lock (triangular) to upper section, DIN 3 lock for lower section and keys to respective lock.
- Degree of protection, switching devices, IP2X.



CDCS



SDCS

Designation	ID No.	Switch-off-power	Max outgoing groups	Free space	Weight
		Rated current		on the busbar	
		A	M*		kg each
CDCS 16015	2CGX0 63301122	160	5	15	79
SDCS 16023	2CGX0 63301123	160	7	23	88
SDCS 25018	2CGX0 63301124	250	6	18	94
SDCS 25043	2CGX0 63301125	250	14	43	115

Options and accessories

Material when several outgoing groups:



SLD 000, SLD 00, SLD 1
Fuse-switch disconnectors.
Degree of protection, IP2X.



AD 70
Non-insulated connector. May only be used with non-protected busbars for 6-95 mm² cable.



ADO 240
Non-insulated connector 120-240 mm².
May only be used with non-protected busbars.

Options and accessories	Rated current	Designation	ID No.	Cable connection	Width	Weight
	A			Al/Cu mm ²		
				M*	kg each	
Outgoing groups	100	SLD 000 (C00)	2CGX0 63050106	2.5-95	3	1.7
Outgoing groups	160	SLD 00 (00)	2CGX0 63050107	2.5-95	4	1.8
Outgoing groups	250	SLD 1 (1)	2CGX0 63050108	50-300	10	4.3
PE-/N clamp	-	AD 70	2CGX0 63030038	6-95	-	0.1
PE-/N clamp	-	ADO 240	2CGX0 63030263	120-300	-	0.25

* One module M = 12.5 mm.

5-wire system

Kit for conversion to 5-wire system, TN-S or TN-C-S.

The kit includes a 400 A non-protected busbar.

- CXX-TNS fits in enclosures type CDC.
- SD XX-TNS fits in enclosures type SDC.

Note:

Regarding upgrading kit for 1000 A busbars, or for use in enclosure type KSIK – please contact your supplier for information.



Designation	ID No.	Fits enclosure	Qty modules	Rated current	Length	Weight
				A	mm	kg each
C20-TNS	2CGX0 53310613	CDC 20	20	400	333	0.6
C40-TNS	2CGX0 53310614	CDC 40	40	400	583	0.7
C60-TNS	2CGX0 53310615	CDC 60	60	400	833	0.9
SD 48-TNS	2CGX0 53320208	SDC 48	48	400	584	0.9
SD 73-TNS	2CGX0 53320219	SDC 73	73	400	898	1.0
SD 98-TNS	2CGX0 53320209	SDC 98	98	400	1212	1.2

Accessories for Enclosures

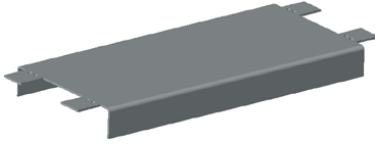

C20-BP, C40-BP, C60-BP
Sheet steel foundation baseplate for CDC/CDCM.



BERG 250
Rock hold for cable distribution cabinets type CDC when installed in rocky ground.



FDM-K
Mounting kit developed for mounting fibre duct module FDM (Ericsson Ribbonet) on Kabeldon IP-system.



FV
Wall bracket for enclosures CDC/CDCM.



FDM
Fibre duct module is used for jointing fibre optic ducts. The duct in the service cable is jointed to a multi-duct cable.

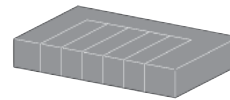

C20-DB, C40-DB, C60-DB
Damp barrier, fits all CDC enclosures.



VF 100
Wall bracket for enclosures CDC and SDC. Keeps the CDC cabinet 100 mm away from the wall of the building. For SDC, the distance from the wall is 8 mm.



KSPS 6
Marking pole.



C60-XA
Extra anchor bar which can be installed under the cover plate in CDC 60. It is used when replacing enclosure where the cable must be jointed.



FVD
Wall spacer, used together with FV.

Designation	ID No.	Suitable for	Dimensions			Weight
			Height	Width	Depth	
			mm			kg each
C 20-BP	2CGX0 53310725	CDC/CDCM 20	27	344	130	0.8
C 40-BP	2CGX0 53310726	CDC/CDCM 40	27	594	130	1.5
C 60-BP	2CGX0 53310727	CDC 60	27	844	130	2.2
FDM-K	2CGX0 53310704	CDC/SDC	-	-	-	0.1
FV	2CGX0 63190225	CDC/CDCM	50	70	135	1.9
BERG 250	2CGX0 63300649	CDC/CDCM	370	130	30	1.9
FDM	2CMA1 31600R1000	CDC/SDC	506	135	93	1.0
C20-DB	2CGX0 53310696	CDC	50	350	215	0.2
C40-DB	2CGX0 53310697	CDC	50	600	215	0.3
C60-DB	2CGX0 53310698	CDC	50	850	215	0.4
VF 100	2CGX0 53310678	CDC/CDCM/SDC/SDCM	40	228	35	0.2
FVD	2CGX0 63190241	FV	-	Ø 47	85	0.7
KSPS 6	2CGX0 63190145	CDC/CDCM/SDC/SDCM	1500	30	30	3.8
C60-XA	2CGX0 53310667	CDC 60	42	935	50	1.7

Accessories for enclosures SDC and SDCM



SLUS 48-98

Door with outlet opening at the bottom for temporary connections. The outlet opening measures 60 mm x 240 mm.



GOLV-S 48-98

Complete foundation when installed on a floor.



BPF-S 48-98

Baseplate with 4, 6 or 10 FL 21 flange openings.



MARK-S 48-98

MARK-S 73-98 LD

Complete foundation when installed in the ground.



VF-S 30

Wall bracket. Two required per cabinet. Gives 30 mm free space behind the cabinet.

Designation	ID No.	Fits enclosure	Dimensions			Weight
			Height	Width	Depth	kg each
			mm			
SLUS 48	2CGX0 53310666	SDC/SDCM 48	288	626	22	5
SLUS 73	2CGX0 53310684	SDC/SDCM 73	288	940	22	7.5
SLUS 98	2CGX0 53310668	SDC/SDCM 98	288	1254	22	10.0
MARK-S 48	2CGX0 63300439	SDC/SDCM 48	940	672	303	30
MARK-S 73	2CGX0 63300549	SDC/SDCM 73	940	986	303	36
MARK-S 73 LD	2CGX0 63300636	SDC 73 LD	940	986	233	34
MARK-S 98	2CGX0 63300440	SDC/SDCM 98	940	1300	303	42
MARK-S 98 LD	2CGX0 63300572	SDC 98 LD	940	1300	233	40
GOLV-S 48	2CGX0 63300441	SDC/SDCM 48	400	672	303	23
GOLV-S 73	2CGX0 63300550	SDC/SDCM 73	400	986	303	30
GOLV-S 98	2CGX0 63300442	SDC/SDCM 98	400	1300	303	36
BPF-S 48	2CGX0 53310629	SDC/SDCM 48	30	672	282	4
BPF-S 73	2CGX0 53310682	SDC/SDCM 73	30	986	282	5
BPF-S 98	2CGX0 53310630	SDC/SDCM 98	30	1300	282	6
VF-S 30	2CGX0 53310643	SDC/SDCM	500	40	40	0.5

Accessories for kWh metering



MPF 25/63 B
Meter panel with terminal block. Meets the requirements of SS 4300101, edition 8.



CKM
Upgrade kit for installing meter panel MPF 25/63 B in accessory cabinet CDCA or in low-profile meter cable cabinet.

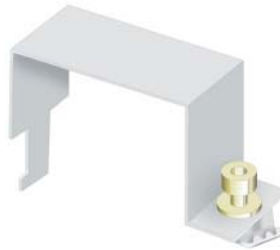

PBKP 25/50
Seal cover for KSKP 25/50.

Designation	ID No.	Description	Rated current	Dimensions			Weight
				Height	Width	Depth	
			A	mm			kg each
MPF 25 B	2CGX0 53310737	Meter panel including terminal block KSKP 25	25	570	220	115	5.0
MPF 63 B	2CGX0 53310738	Meter panel including terminal block KSKP 50	63	570	220	115	5.0
CKM	2CGX0 53390034	Upgrade kit	-	-	-	-	0.02
PBKP 25	2CGX0 53050141	Seal cover	-	-	80	-	0.1
PBKP 50	2CGX0 53050142	Seal cover	-	-	96	-	0.1

Accessories for kWh metering



TRAFO-CD 630, TRAFO-SD 630/1200
Complete kits for current transformer metering. To be used for 630 A or 1200 A.

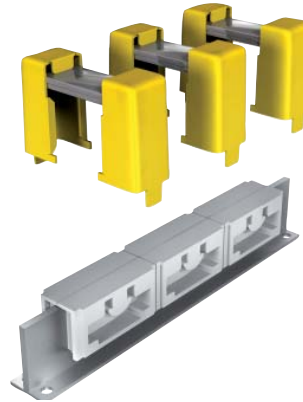

KSSM-S 630/1200
Busbar bridges incl. busbar supports for current transformer. For 630 A or 1200 A. May only be installed on dead busbar..

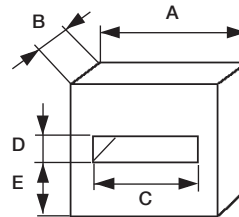

TRAFO-CD and TRAFO-SD contains:

1 kit	Busbar bridges incl. busbar supports
1	Fuse-switch disconnector, SLD 000
2	Neutral terminals, ADC 25
1	Seal cover

Rated current	A	B(max)	C(min)	D(min)	E(max)
A	mm	mm	mm	mm	mm
630	85	50	30	10	40
1200	100	50	60	20	40

Designation	ID No.	Fits enclosure	Qty Modules	Rated Data	Weight
					kg each
TRAFO-CD 630	2CGX0 63190392	CDC, CDCM, CDCP	13	500 V, 630 A	5.5
TRAFO-SD 630	2CGX0 63190391	SDC, SDCM, KSIK	13	500 V, 630 A	5.5
TRAFO-SD 1200	2CGX0 63190390	SDC, SDCM, KSIK	19	500 V, 1200 A	8.9
KSSM-S 630	2CGX0 63090017	SDC, SDCM, KSIK	9	500 V, 630 A	2.7
KSSM-S 1200	2CGX0 63090018	SDC, SDCM, KSIK	15	500 V, 1200 A	6.1

Accessories for kWh metering



MPP 20
Mounting plate, steel, for upper section of CDCM. Two plates are used for CDCM X40.



MPT 40
Mounting plate, wood, for upper section of CDCM X40.



MPP-S 48, MPP-S 73
Mounting plate, steel, for the upper section of enclosures type SDCM X48 and SDCM X73. Two plates are used for SDCM X98.



MPT-S 48
MPT-S 73
Mounting plate, wood, for the upper section of SDCM X48 and SDCM X73. Two plates MPT-S 48 are used for SDCM X98.



KSMP-S 48, KSMP-S 73, KSMP-S 98
Mounting plate, steel, for SDC and the lower section of enclosures type SDCM. KSMP-S 48/73 is perforated with hole pitch 38 mm (Ø 3.5).

Designation	ID No.	Fits enclosure	Dimensions			Weight
			Height	Width	Depth	
			mm			kg each
MPP 20	2CGX0 53310665	CDCM	540	268	25	2.0
MPT 40	2CGX0 53310724	CDCM	550	550	12	1.75
MPP-S 48	2CGX0 53190334	SDCM	580	585	25	3.0
MPP-S 73	2CGX0 53310735	SDCM	580	856	25	7.0
MPT-S 48	2CGX0 53310647	SDCM	580	600	12	2.2
MPT-S 73	2CGX0 53310688	SDCM	580	890	12	3.3
KSMP-S 48	2CGX0 53190332	SDC, SDCM	780	660	21	5.0
KSMP-S 73	2CGX0 53190335	SDC, SDCM	780	974	21	8.0
KSMP-S 98	2CGX0 53190333	SDC, SDCM	780	1268	21	11.0

Accessories

Locks and tools



CDC-LT
Triangular lock for CDC/
CDCM.



CDC-LSE
SE lock for CDC/CDCM.



SDC-LA
Customer lock for SDC/
SDCM.



SDC-LTC
Lock for SDC/SDCM with
equipment for telecommu-
nication.



CDC-LA
Customer lock for CDC/
CDCM.



CDC-LTC
Lock for CDC/CDCM with
equipment for telecommu-
nication.



SDC-LD
DIN lock for SDC/SDCM.

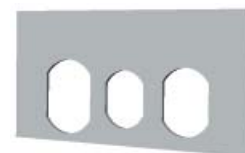

CDC-CLA
Kit for fitting cylinder lock
type ASSA Abloy/Trioving
to CDC.



CDC-LD
DIN 3 lock CDC/CDCM.



SDC-LT
Triangular lock for SDC/
SDCM.



SDC-LSE
SE lock for SDC/SDCM.



KSCA
Adaptor ring for ASSA
Abloy lock for SDC.

Designation	ID No.	Suitable key						Weight kg each
		KSNR 4	NK 3	NK 5	NK 30	NKD 3	NK-TC	
CDC-LT	2CGX0 43310739	-	x	x	x	-	-	0.1
CDC-LA	2CGX0 43310740	x	x	x	x	-	-	0.1
CDC-LD	2CGX0 43310742	-	-	-	-	x	-	0.1
CDC-LSE	2CGX0 43310743	-	-	-	x	-	-	0.1
CDC-LTC	2CGX0 43311040	-	-	-	-	-	x	0.1
SDC-LT	2CGX0 43310597	-	x	x	x	-	-	0.1
SDC-LA	2CGX0 43310596	x	x	x	x	-	-	0.1
SDC-LD	2CGX0 43310595	-	-	-	-	x	-	0.1
SDC-LSE	2CGX0 43310598	-	-	-	x	-	x	0.1
SDC-LTC	2CGX0 43310599	-	-	-	-	-	x	0.1
CDC-CLA	2CGX0 53310669	-	-	-	-	-	-	0.1
KSCA	2CGX0 53190278	-	-	-	-	-	-	0.1

Accessories

Keys and tools



KSNR 4
Key for customer lock.



NKD 3
Key for DIN lock.



VHB 68
Insulating hand tool. 6 and 8 mm hexagon spanner. Fits torque wrench with 1/2" square peg.



NK 3
Key for triangular lock with door opener. The door opener is used to facilitate opening the enclosure if the door has jammed.



NK 30
Key for triangular lock and SE lock with door opener. The door opener is used to facilitate opening the enclosure if the door has jammed.



NK-TC
Key for lock for CDC-LTC and SDC-LTC with door opener. The door opener is used to facilitate opening the enclosure if the door has jammed.

Designation	ID No.	Weight
		kg each
KSNR 4	2CGX0 43190104	0.1
NKD 3	2CGX0 43190661	0.1
VHB 68	2CGX0 63090014	0.4
NK 3	2CGX0 63190370	0.1
NK 30	2CGX0 63190369	0.1
NK-TC	2CGX0 63190373	0.1

Examples of combinations of enclosures



CDC 40 + SDC 98



SDC 48 + SDC 98



SDC 98 + SDCM 48



SDCM 48 + SDCM 98

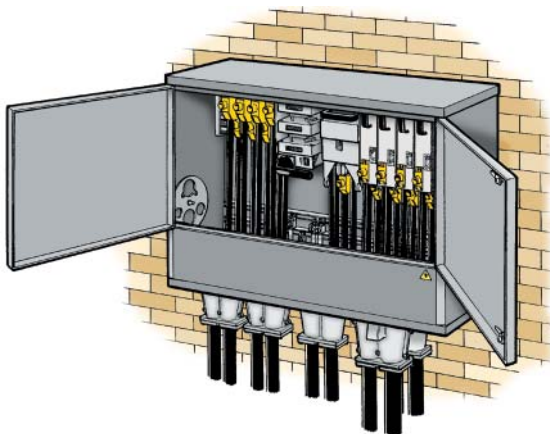

SDC 98 + BPF-S 98



CDC 40 + CDCA

Dimension drawings

All dimensions in mm

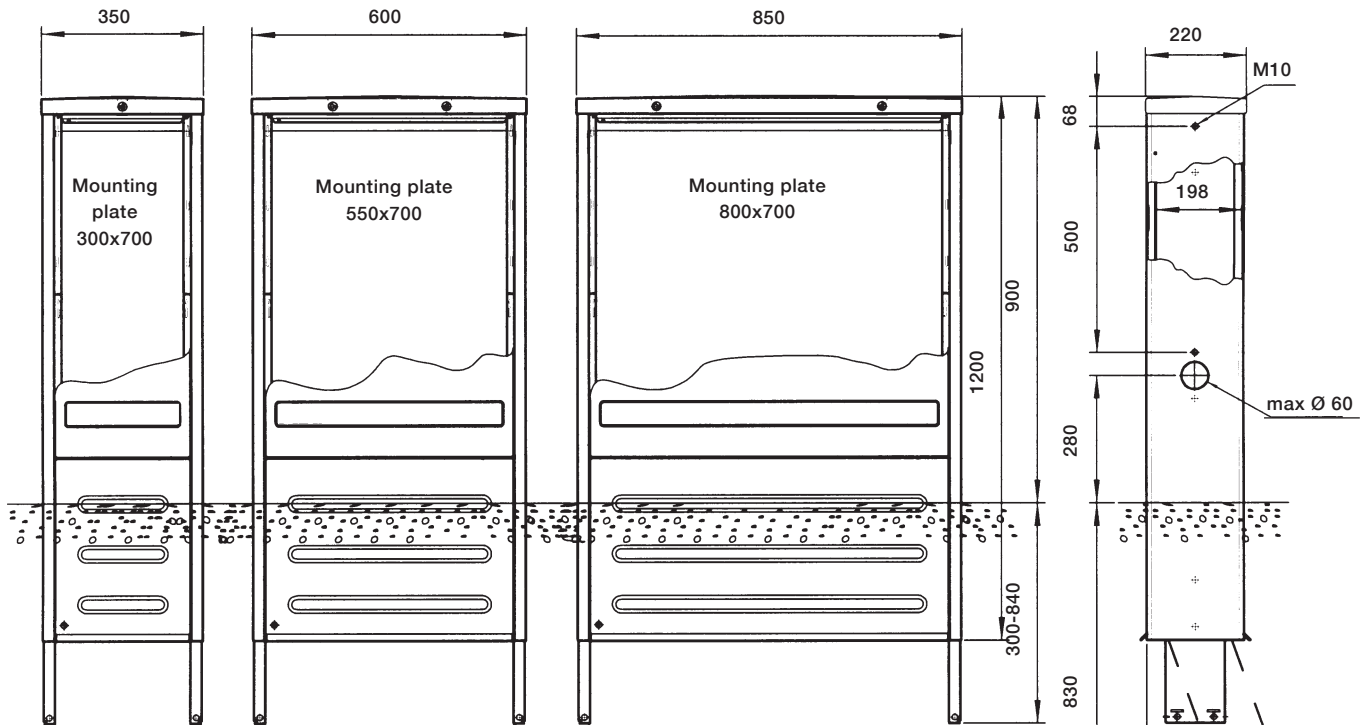

Enclosures CDC

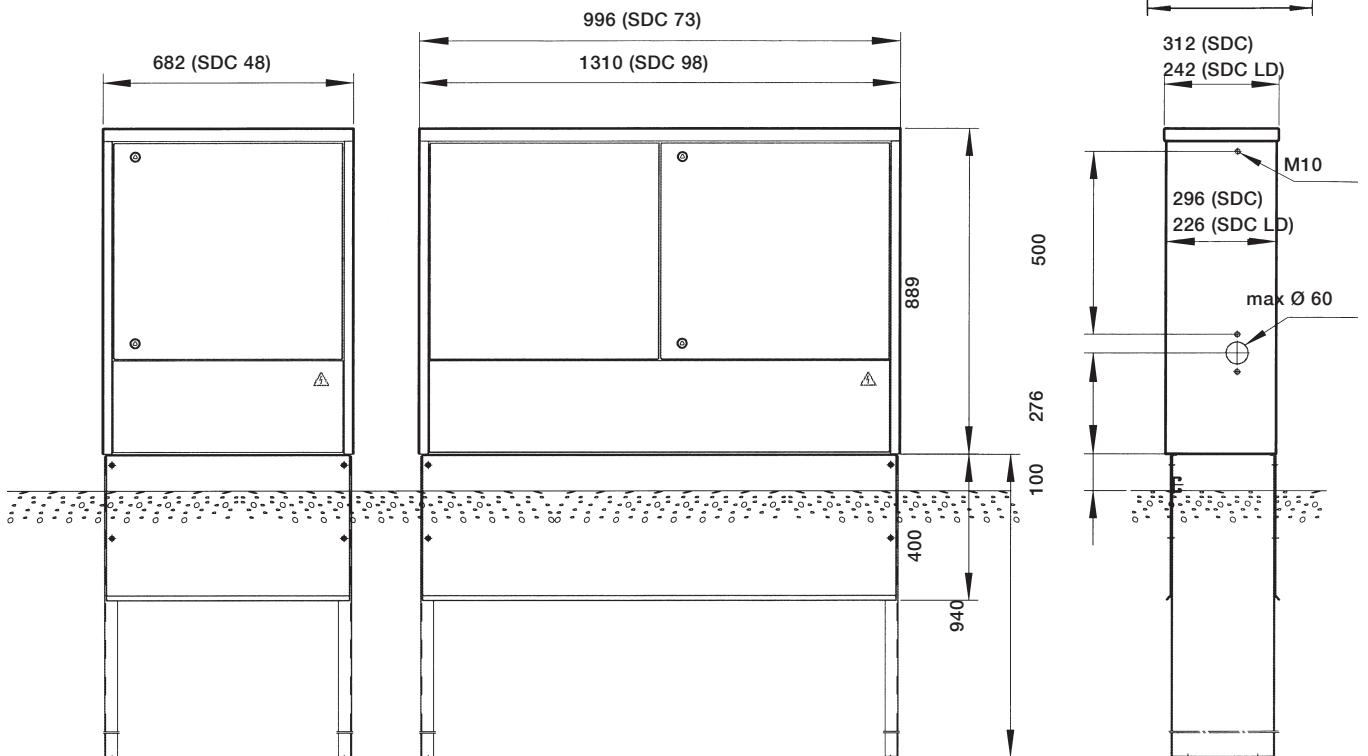

Enclosures SDC

Dimension drawings

All dimensions in mm

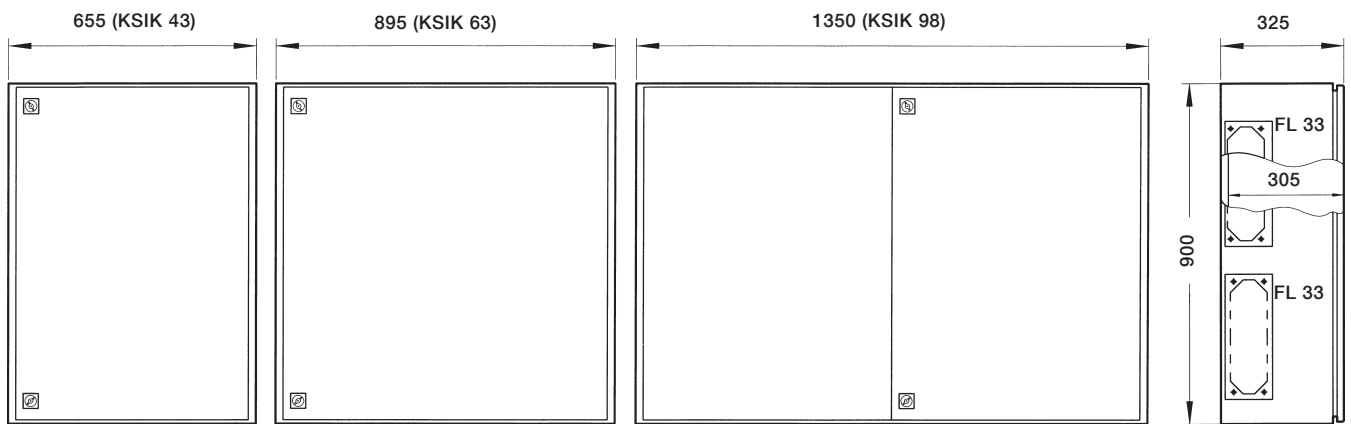

Enclosures KSIK

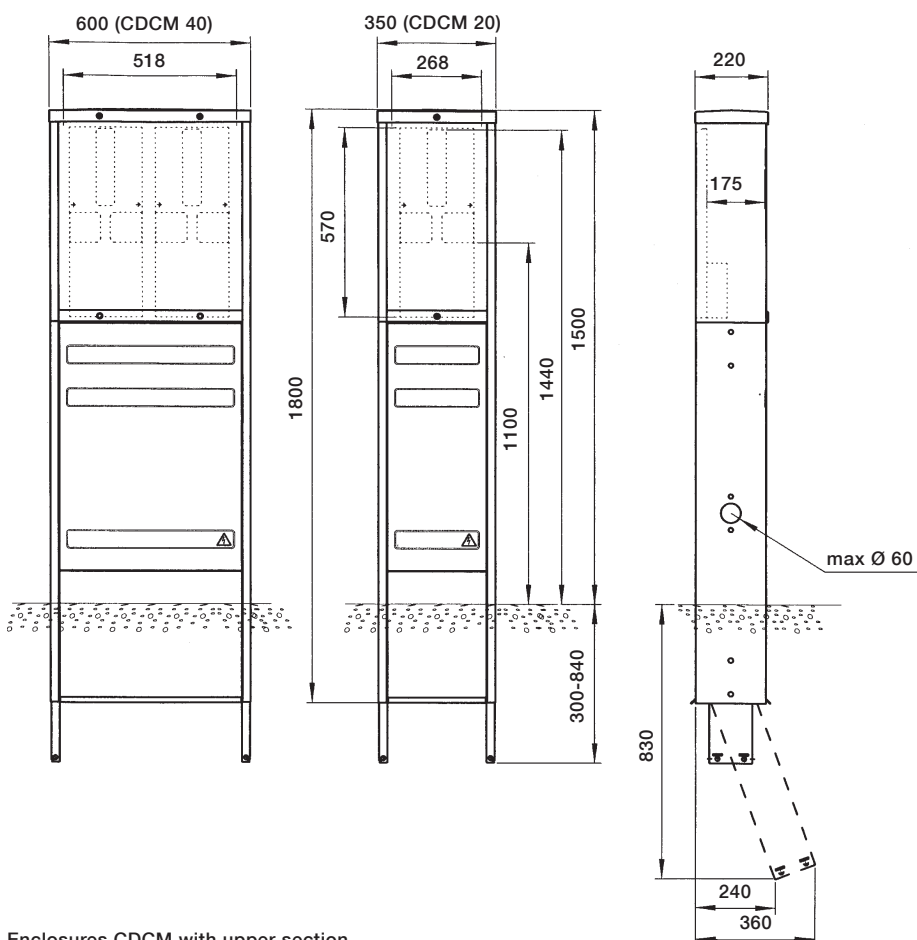

Enclosures CDCM with upper section

Dimension drawings

All dimensions in mm

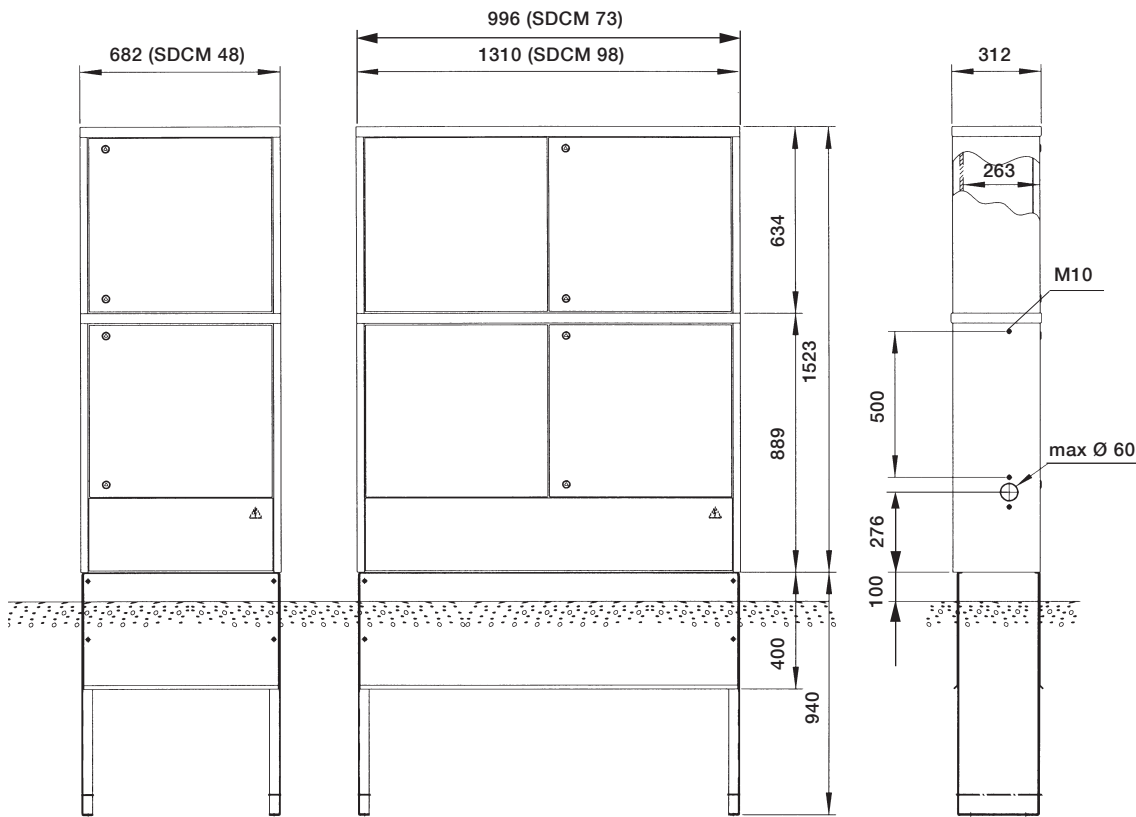

Enclosures SDCM with upper section

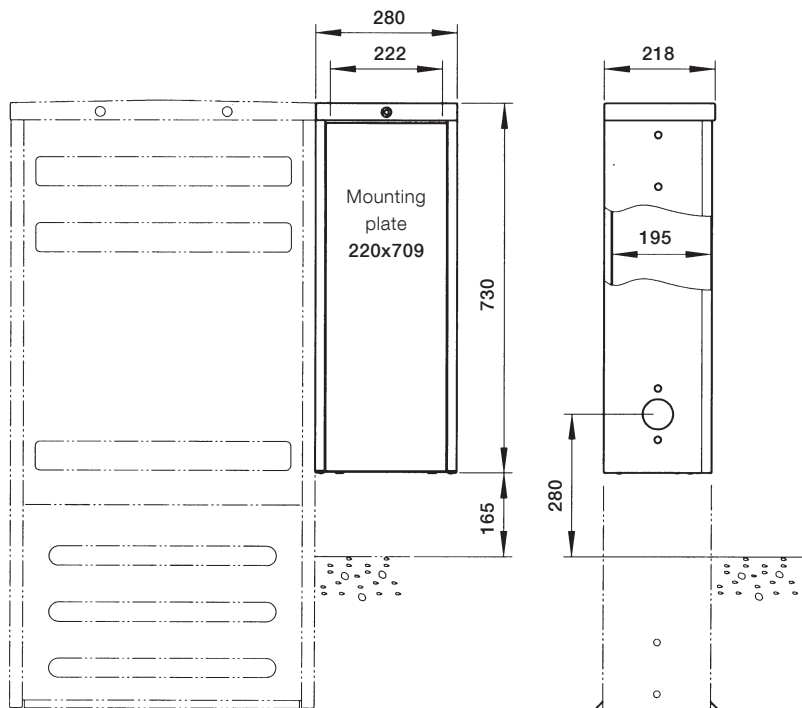

Accessory cabinet CDCA

Dimension drawings

All dimensions in mm

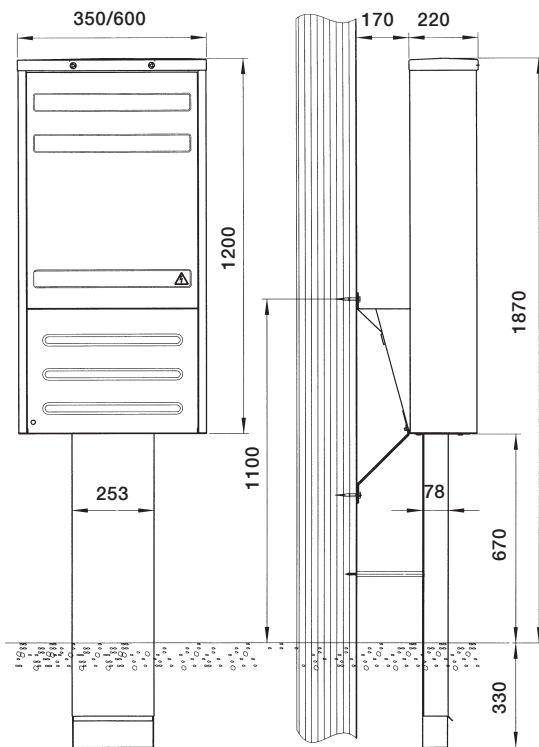

Pole mounted cable distribution cabinets CDCP

Technical data

Busbar system		400 A		630 A		1000 A		1600 A		1600 A	2500 A
										CSS ²⁾	CSS ²⁾
Rated operational voltage, U_g	V	690		690		690		690		690	690
Rated insulation voltage, U_i	V	1000		1000		1000		1000		1000	1000
Rated conventional thermal current, I_{th} and rated operational current, I_g	A	400		630		1000		1600		1600	2500
Rated short-time withstand current, I_{sw}	kA _{rms/s}	30/0.2 ¹⁾		23/1 ¹⁾		40/1 ¹⁾		70/1 ¹⁾		30/1	65/1
Rated fused short-circuit current, I_{cf}	kA _{rms}	50	85	50	85	–	–	–	–	–	–
	max A	3//315	3//250	3//315	3//250	–	–	–	–	–	–
Rated peak withstand current, I_{pk}	kA _{peak}	55		55		–		–		67	148
Rated peak withstand current; 1 m long busbar without fitted device, I_{pk}	kA _{peak}	–		–		50		85		–	–
Degree of protection according to IEC 60 529		IP2X		IP2X		IP2X		IP2X		IP2X	IP2X

- 1) Test prerequisite: $\Delta T=100$ K. Final temperature of the busbar max. 150° C.
2) Adjusted for use in substations and low voltage switchgears.

Switching device with dependent manual operation, uninterrupted duty		SLD 000		SLD-FHD 000		SLD 00		SLD-FHD 00		SLD 1		SLD 2		FD 3300
Rated operational voltage, U_g	V	400	690 ¹⁾	230	400	690 ¹⁾	230	400	690 ¹⁾	400	690 ¹⁾	1000 ¹⁾	400	
Rated insulation voltage, U_i	V	690		690		690		690		690		1000		690
Rated impulse withstand voltage, U_{imp}	kV	8		8		8		8		8		8		8
Rated operational current, I_g and rated conventional thermal current, I_{th} ²⁾	A	100	80	100	160	160	160	250	250	400	355	160	400	
Utilization category according to IEC 60947-3		AC-23B	AC-22B	AC-21B	AC-23B	AC-21B	AC-21B	AC-23B	AC-22B	AC-23B	AC-22B	AC-21B	AC-21B	
Rated short-time withstand current, I_{sw}	kA _{rms/s}	6.1/1 ⁵⁾		–	6.1/1 ⁵⁾		–	16.2/1 ⁵⁾		16.2/1 ⁵⁾		15/1		
Rated peak withstand current, I_{pk}	kA _{peak}	10.9 ⁵⁾		–	10.9 ⁵⁾		–	34.4 ⁵⁾		34.4 ⁵⁾		42		
Rated conditional (fused) short-circuit current, I	kA _{rms}	50	30	30	50	30	30	50	50	50	50	30	50	
Degree of protection according to IEC 60529	fuse	IP2X ⁴⁾		IP2X ⁴⁾		IP2X ⁴⁾		IP2X ⁴⁾		IP2X		IP2X		IP2X
Connectable conductor cross-section, Cu/Al	mm ²	2.5-95		2.5-95		2.5-95		2.5-95		50-300		50-300		50-300

Remarks

- 1) To be used only in dry environments.
2) Fuse with power dissipation according to IEC 60269-2-1.
3) With linking knives.
4) IP1X at operation, depending on design dimensions of the fuse.
5) Tested with the earthing device JDD.

Technical data

Switching device with independent manual operation	SEKO			SEKOD		SLOB			LBOC	
		160	250	400	400	630	800	630	800	1600
Rated operational voltage, U_e	V	690	690	690	690	690	690	690	690	690
Rated insulation voltage, U_i	V	750	1000	1000	1000	1000	1000	1000	1000	1000
Rated impulse withstand voltage, U_{imp}	kV	–	12	12	–	–	–	–	–	–
Rated conventional thermal current, I_{th} and rated operational current, I_e	A	160	224 250 ²⁾	355 ¹⁾ 400 ²⁾	355 ¹⁾ 40 ²⁾	630	800	630	800	1600
Utilization category according to IEC 60947-3		AC-22A	AC-23A	AC-23A	AC-23A	AC-23A	AC-22A	AC-23A	AC-22A	AC-22A
Rated short-time withstand current, I_{Dw}	kA _{rms/s}	5	8	14	14	16	16	17	17	50
Rated peak withstand current, I_{pk}	kA _{peak}	–	–	–	–	–	–	80	80	105
Rated conditional fused short-circuit current, I_{ct}	kA _{rms}	29	46	50	50	50	50	–	–	–
	Fuse max A	160	400	400	400	630	800	–	–	–
Degree of protection according to IEC 60529		IP2X	IP2X	IP2X	IP2X	IP2X	IP2X	IP2X	IP2X	IP2X
Connectable conductor cross-section, Cu/Al	mm ²	50-300	50-300	–	–	–	–	–	–	–

1) Mounting with horizontal fuses limits the current by 8 % which gives the fuse sizes according to the table.

2) With linking knives 250 and 400 A respectively.

Connectors IEC 61238-1		ADC 25	AD 70	ADO 240	AD 350	AD 95	AD 300	AD 400	AD 2150	ADB 3M
Rated operational voltage, U_e	V	690	690	690	690	690	690	690	690	500
Rated insulation voltage, U_i	V	–	–	–	–	690	690	690	690	690
Rated conventional thermal current, I_{th} and rated operational current, I_e	A	63	200	400	400	200	630	630	400	500
Max. fuse	A	–	–	–	–	–	–	–	2//200	–
Rated short-time withstand current, I_{Dw}	kA _{rms/s}	–	19/1	–	25/1	30/0.2	30/1	35/1	30/0.2	–
Rated conditional short-circuit current with fuse I_{ct}	kA _{rms}	–	50	50	50	50	50	–	50	–
	max. A	–	200	400	400	200	400	–	2//200	–
Degree of protection according to IEC 60529		–	–	–	–	IP2X	IP2X	IP2X	IP2X	IP2X
Connectable conductor cross-section Cu/Al	mm ²	1.5 - 25	6 - 95	120-240	3 x 6-50	6 - 95	50 - 300	50-400	35-2//150	50-300

Connectors		KSSM-S 630	KSSM-S 1200	AB 800	AB 1200	ADR M8/M12	ADR H12
Rated operational voltage, U_e	V	500	500	500	500	–	–
Rated insulation voltage, U_i	V	690	690	690	690	–	–
Rated conventional thermal current, I_{th} and rated operational current, I_e	A	630	1200	800	1200	630	630
Degree of protection according to IEC 60529		IP2X	IP2X	–	–	–	–

Technical data

Switching devices with independent manual operation	AS-T3		KLAP T5 630		
		with SACE Tmax T3	with SACE Tmax T5		
Rated operational voltage, U_e	V	400	690	400	690
Rated insulation voltage, U_i	V	800	–	–	1000
Rated impulse withstand voltage, U_{imp}	kV	600	–	–	8
Rated conventional thermal current, I_{th} and rated operational current, I_e	A	250		525	
Utilization category according to IEC 60947-2		A		B	
Rated short-time withstand current, I_{cw}	kA _{rms/s}	27		5	
Rated conditional short-circuit current, I_{cc}	kA _{peak}	50	8	50	25
Degree of protection according to IEC 60529, mounted		IP2X	–	–	IP2X
Connectable conductor cross-section, Cu/Al	mm ²	50-300	–	–	–

Accessories		PHD 2	PHD 2 SDC	JDDA 000	JDDA 00	JDDA 1	JDDA 2	KBS 20
Rated operational voltage, U_e	V	400	400	–	–	–	–	–
Rated insulation voltage, U_i	V	690	690	690	690	690	690	690
Rated conventional thermal current, I_{th} and rated operational current, I_e	A	400 ¹⁾	400 ¹⁾	–	–	–	–	–
Utilization category acc to IEC 60947-3		AC-23B	AC-23B	–	–	–	–	–
Rated short-time withstand current, I_{cw}	kA _{rms/s}	–	–	6.1/1	6.1/1	16.2/1	16.2/1	21.1/1 ²⁾
Rated peak withstand current, I_{pk}	kA _{peak}	–	–	10.9	10.9	34.4	34.4	43.3 ²⁾
Rated fused short-circuit current, I	kA _{rms}	50	50	–	–	–	–	–
		400	400	–	–	–	–	–

Remarks

1) Fuses with power dissipation according to IEC 60269-2-1.

2) With 95 mm² earthing cable.

Cable distribution cabinets		400 A		630 A	
Rated operational voltage, U_e	V	400		400	
Rated insulation voltage, U_i	V	1000		1000	
Rated conventional thermal current, I_{th} and rated operational current, I_e	kV	400		630	
Max. fuse	A	3//315		3//315	
Rated short-time withstand current, I_{cw}	A	30/0.2 ¹⁾		23/1 ¹⁾	
Rated fuse short-circuit current, I_{cf}	kA _{rms/s}	50	85	50	85
	max A	3//315	3//250	3//315	3//250
Rated peak withstand current, I_{pk}	kA _{peak}	50		50	
Degree of protection acc. to IEC 60529	Busbar system	IP2X		IP2X	
	Enclosure	IP34D		IP34D	

1) Test prerequisite: $\Delta T=100$ K. Final busbar temperature max. 150° C.

Torque wrench for switching devices and enclosures

Designation	Against phase busbar	Cable connection			
		2.5-35 mm ²	50-95 mm ²	120-300 mm ²	Others
SLD 000	15 Nm	15 Nm	20 Nm	-	-
SLD 00					
SLD 1	15 Nm	-	20 Nm	35 Nm	-
SLD 2					
FD 3300	20 Nm	-	20 Nm	45 Nm	-
AD 95	20 Nm	20 Nm(from 6 mm ²)	20 Nm	-	-
AD 300	20 Nm	-	20 Nm	45 Nm	-
ADO 240	15 Nm	-	-	35 Nm (max 240 mm ²)	-
AD 70	20 Nm	20 Nm (from 6 mm ²)	20 Nm	-	-
AD 350	20 Nm	20 Nm (from 6 mm ²)	20 Nm (max 50 mm ²)	-	-
ADB 3M	20 Nm	-	-	-	20 Nm ¹⁾
SEKO 160	20 Nm	-	20 Nm	45 Nm	20 Nm ²⁾
SEKOB 250/400					
AS-T3					
KLAP T5	20 Nm	-	-	-	20 Nm ³⁾
TRAFO-C/S 630	20 Nm	-	-	-	-
KSSM-S 630/1200					
KLKB-S 630/1200					

1) Adapter - Plug-in socket

2) Connector - Breaker

3) Adapter - Plug-in socket

Designation	Cable connection							Screw
	6 mm ²	50 mm ²	95 mm ²	120 mm ²	150 mm ²	185 mm ²	300 mm ²	M10
TC 50-12	12 Nm							
TC 70-15		20 Nm		25 Nm		45 Nm		
TC 120-20								
TC 300-25								
TCD 185-25			20 Nm					35 Nm
TC 300-40			35 Nm			45 Nm		35 Nm
TCD 300-40								

Designations in alphabetical order

Designation	Page No.
A	
AB 1200-53/ 1200-70/ 800-53	37
AB 2500 CSS	34, 35
AD 2150	29
AD 300	29
AD 350	29, 68
AD 400	29
AD 70	29,70
AD 95	29
ADB 3M	29
ADC 25	29, 68
ADN	29
ADO 240	29, 70
ADR H12/ ADR M10/ ADR M8	37
AS-T3	28
B	
BERG 250	55, 72
BK-E/ BK-N/ BK-T	55
BPF-S 48/73/98	73
C	
C 20-BP/C 40-BP/ C 60-BP	72
C20-DB/C40-DB/ C60-DB	55, 72
C 20-TNS/C 40-TNS/ C 60-TNS	36, 71
C 60-XA	72
CC 20/CC 30	55
CDC 020/040/060	52, 54
CDC 420/440/460/640/660	52
CDC-CLA	77
CDC-LA	77
CDC-LD	77
CDC-LSE	77
CDC-LT	77
CDC-LTC	55, 77
CDCA	66
CDCA-CD	67
CDCM 020/040/420/440/640	60
CDCP 020/040/420/440	64
CDCP-TP	65
CDCS 16015/CDCS 16018	70
CDCS 25018/CDCS 25043	70
CDCS 2520/CDCS 6320	69
CKM	67, 74
Connect IT	11
E	
EB 435	55
F	
FD 3300	25

Designation	Page No.
F	
FDM	55, 72
FDM-K	55, 72
FH-S 250/400	26
FHD 00/FHD 000	22
FHH	21
FHHD-A 000	20
FHHD-A 00	21
FV	72
FVD	72
G	
GBC 45-2, GBC 63-3	68
GBL 63/GBLB 45	38
GOLV-S 48/73/98	70
I	
ILM 250	26
ILM 400	26
J	
JDDA 000	20
JDDA 00	21
JDDA 1	23
JDDA 2	24
K	
KBS 20	35
KFBD	25
KHB 3/KHB 5/ KHB 7	65
KKC 5	65
KKCS	65
KKS	65
KLAP T5 630	28
KLKB-S 1200/ KLKB-S 630	32
KN 00	20,21,26
KN 1	23, 26
KNB 2	24
KSB 20	37
KSBD 00	20, 21
KSBD 2	23, 24
KSBH 300	29
KSCA	77
KSFS	30
KSFS 16151 CSS, KSFS 16183 CSS	34
KSFS 25150 CSS, KSFS 25182 CSS	35
KSIK 043/063/098	58
KSJH 2	39
KSKP 25/ KSKP 50	42
KSMP-S 48/73/98	55, 76
KSMUB 16/32	67

Designations in alphabetical order

Designation	Page No.
K	
KSNR 4	78
KSNS	31
KSPS 6	72
KSSM-S 630/1200	75
KSST 36	32
KSST 36 - CDC	32
KSST 316	32
KSST 316/100	32
KSST 316/23	32
KSST 325 CSS, KSST 25182 CSS	35
KSST-CDC	32
KSSTD 312/16	34
L	
LBOC 630/800/1600	27
M	
MARK-S 48/73/98	73
MARK-S 73/98 LD	73
MCB 24	39
MPF 25/63 B	67, 74
MPP 20	76
MPP-S 48	76
MPT 40	76
MPT-S 48/73	76
MSB 316	33
MSB 316/100	33
MSB 316/23	33
MSB 325 CSS	35
MSBD 312/16	34
N	
NK 3	78
NK 30	78
NKD 3	78
NK-TC	55, 78
P	
PBKP 25/50	42, 74
PHD 2	24
PHD 2 SDC	24
PSFS 5/17	42
PSM 250	26
R	
RKMB 900	37
S	
SD 48-TNS/SD 73-TNS/SD 98-TNS	36, 71

Designation	Page No.
S	
SCA	41
SDC 048/073/098	56
SDC 448/473/648/673/698	56
SDC 673 LD/SDC 698 LD	56
SDC-LA	77
SDC-LD	77
SDC-LSE	77
SDC-LT	77
SDC-LTC	55, 77
SDCM 048/073/098	62
SDCS 16023/25018/25043	62
SEKO 160	70
SEKOD 250/400	26
SLD 00	21, 70
SLD 000	20, 68, 69, 70
SLD 1	23, 70
SLD 2	24
SLD-FHD 00/000	22
SLOB 400/630/800	27
SLUS 48/73/98	73
STM 400	23, 24
SVA	41
T	
TC	38
TCD	38
TFU 25	39
TRAFO-CD 630	75
TRAFO-SD 630/1200	75
U	
UKRA 90	39
V	
VF-S 30	73
VF100	72
VHB 68	78

Contact us

ABB AB

Kabeldon

BOX 531

SE-441 15 Alingsås, Sweden

Tel: + 46 322 770 00

Fax: +46 322 770 01

www.abb.se/kabeldon

© Copyright 2011 ABB. All rights reserved.

Document ID: 7ABA102190