

# CAA-M

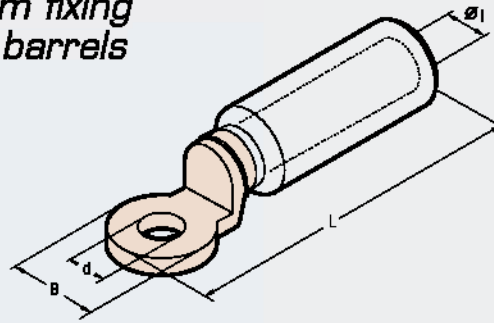

## BIMETALLIC CONNECTORS

*copper palm fixing aluminium barrels*



The barrel of series CAA-M connectors are made from aluminium of a purity equal to or greater than 99,5%. The barrel is friction welded to the palm thus achieving the best possible transition between the copper palm and aluminium barrel. Barrels are capped and filled with grease so as to avoid oxidation of the aluminium.

Conductor Size sqmm	Ø Stud mm	Ref.	Dimensions mm				Quantity Box/Bag	Hydraulic Tools
			Ø1	B	L	d		
10	12	CAA 10-M 12	4,3	24	B7	13	90/3	HT 131-UC RHU 131-C B 131-UC
16	12	CAA 16-M 12	5,5	24	B7	13	90/3	
25	12	CAA 25-M 12	6,5	24	B7	13	90/3	
35	12	CAA 35-M 12	8,0	24	B7	13	90/3	
50	12	CAA 50-M 12	9,0	24	B7	13	60/3	
70	12	CAA 70-M 12	11,0	24	B7	13	60/3	
95	12	CAA 95-M 12	12,5	24	B7	13	60/3	
120	12	CAA 120-M 12	13,7	31	111	13	30/3	
150	12	CAA 150-M 12	15,5	31	111	13	30/3	
185	12	CAA 185-M 12	17,0	35	116	13	24/3	
240	12	CAA 240-M 12	19,5	35	116	13	18/3	
300	12	CAA 300-34-M 12	22,5	35	120	13	15/3	

## BIMETALLIC CONNECTORS

# MTA-C



*copper pin aluminium barrels*

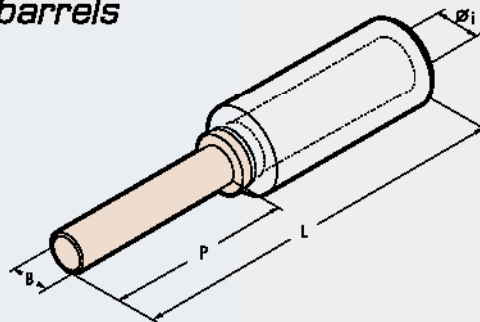

The barrel of series MTAC connectors are made from aluminium of a purity equal to or greater than 99,5%. The barrel is friction welded to the pin thus achieving the best possible transition between the copper pin and aluminium barrel. Barrels are capped and filled with grease so as to avoid oxidation of the aluminium.

Conductor Size sqmm	Ref.	Dimensions mm				Quantity Box/Bag	Hydraulic Tools
		Ø1	B	P	L		
16	MTA 16-C	5,5	B	30	B2	90/3	HT 131-UC RHU 131-C B 131-UC
25	MTA 25-C	6,5	B	30	B2	90/3	
35	MTA 35-C	8,0	B	30	B2	90/3	
50	MTA 50-C	9,0	12	45	97	60/3	
70	MTA 70-C	11,0	12	45	97	60/3	
95	MTA 95-C	12,5	12	45	97	60/3	
120	MTA 120-C	13,7	14	55	125	30/3	
150	MTA 150-C	15,5	14	55	125	30/3	
185	MTA 185-C	17,0	14	55	125	24/3	
240	MTA 240-C	19,5	14	55	125	24/3	