

LOVOS

Low voltage surge arrester

Catalogue card



ABB

LOVOS-5 and LOVOS-10 are a new generation of low voltage surge arresters

- **LOVOS-5 LOVOS-10** are a new generation of low voltage surge arresters, designed in close cooperation with clients from the whole world, taking into account all needs and requirements of the market.
- **LOVOS-5 i LOVOS-10** ensure protection of low voltage overhead lines of individual electric energy receivers, distributing transformers and other low voltage power equipment from effects of lightning and switching overvoltage.



LOVOS-5 and LOVOS-10 ensure protection of low voltage overhead lines



PRINCIPLE OF OPERATION

- The principal "active" element of the surge arrester is a metal oxide varistor characterised by high non-linearity. At a working voltage mainly a capacity current flows smaller than 1 mA. Any voltage increase causes a large increase of current flowing through the varistor, leading in turn to immediate limitation of further voltage increase on arrester terminals. When the overvoltage disappears, the arrester immediately returns to its basic state.
- Surge arresters are equipped with a disconnecting device, that disconnects the arrester from the network if it becomes damaged as the result of overvoltage of too high energy or inadmissible voltage increase in the system. If such a situation occurs then the bottom terminal of the disconnecting device is "rejected" by the spring inside. This terminal remains suspended on an insulation "leash".

ADVANTAGES:

- Easy assembly and connection
- Disconnecting device simultaneously fulfilling the function of damage indicator
- Large choice of accessories
- Casing resistant to UV radiation, non-flammable
- Maintenance-free product
- All accessories are made of corrosion-resistant materials

APPLICATION:

- Outdoor and indoor
- Altitude: up to 2000 m over sea level
- Ambient temperature in place of work or storage from -40°C to +70°C



Lovos-5 Lovos-10

COMPLIANCE WITH STANDARDS:

- IEC 61643-1; 2005-05 „Surge protective devices connected to low voltage power distribution systems Part 1: Performance requirements and testing methods“.
- EN 61643-11:2002/A11:2007 Low-voltage surge protective devices - Part 11: Surge protective devices connected to low-voltage power systems – Requirements and tests.
- DIN/VDE 0675/6 (Überspannungableiter zur Verwendung in Wechselstromnetzen mit Nennspannungen zwischen 100V und 1000V)

CHARACTERISTICS

SPD type	limiting voltage
Number of terminals	one
SPD type (acc. to IEC 61643-1;2005)	Class II
SPD type (acc. to DIN/VDE 0675/6)	A
Test classification	acc. to IEC 61643-1;2005 - class II tests
For system voltages	up to 1 kV
Location	Outdoor and indoor
Accessibility	Inaccessible (out of reach)
Method of installation	Permanent (name plate "downwards")
SPD disconnecting device	located internally
Ambient temperatures	from -40°C to +70°C
Protection degree	IP 06 for standard execution IP 66 with insulated accessories
Nominal discharge current I_n 8/20 μ s	5 or 10 kA (peak value)
Maximum discharge current I_{max} 8/20 μ s	25 or 40 kA (peak value)
Limiting discharge current*	40 kA or 65kA 4/10 μ s
Voltage protection level U_p	acc. to guaranteed data table
Continuous operating voltage U_c	280, 440, 500, 660, 800, 1000 V AC (effective value)
Energy absorption capability**	4, 5 or 7 kJ / kV U_c
Short-circuit withstand	3 kA
Frequency	up to 62 Hz
Total creepage distance	62 mm

* (requirement acc. to IEC 60099-4); ** measured at one limiting surge 4/10 μ s

GUARANTEED DATA

Arrester type	U_c (effective value)	U_p at I_n	I_n / I_{max}	U_p at I_{max}	Energy absorption capability	U_p at long lasting surge 2000 μ s
	V	V	kA	V	J	V
LOVOS - 5/280	280	1100	5 / 25	1500	1800	850
LOVOS - 5/440	440	1800		2500	3000	1300
LOVOS - 5/500	500	2000		2600	3200	1600
LOVOS - 5/660	660	2500		3200	4000	1800
LOVOS - 5/1000	1000	4000		5200	6400	3200
LOVOS - 10/280	280	1100	10 / 40	1700	2200	900
LOVOS - 10/440	440	1800		2700	3300	1400
LOVOS - 10/500	500	2000		3200	3900	1700
LOVOS - 10/660	660	2500		3800	4500	1900
LOVOS - 10/1000	1000	4000		5800	7800	3400

BASIC SELECTION PRINCIPLES FOR SURGE PROTECTION EQUIPMENT IN A LOW VOLTAGE DISTRIBUTION NETWORK

SPD (Surge Protective Device) selection criteria

- continuous operating voltage U_c
- voltage protection level U_p
- energy absorption capability

Configuration in the low voltage network and applied earthing system.

- T: direct connection to earth
- N: neutral
- C: combined
- S: separate

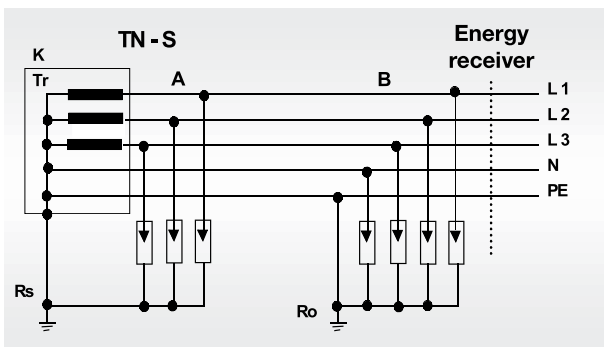

a) TN-S the supply network has a connection of the neutral conductor with the earthing conductor at the feeding transformer only

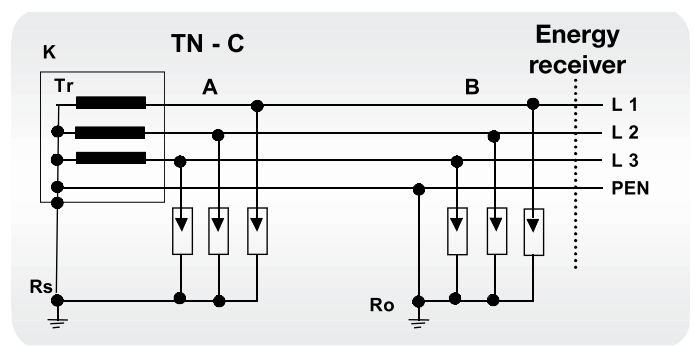

b) TN-C neutral and earthing conductor are common (PEN) and earthed at the transformer or near it

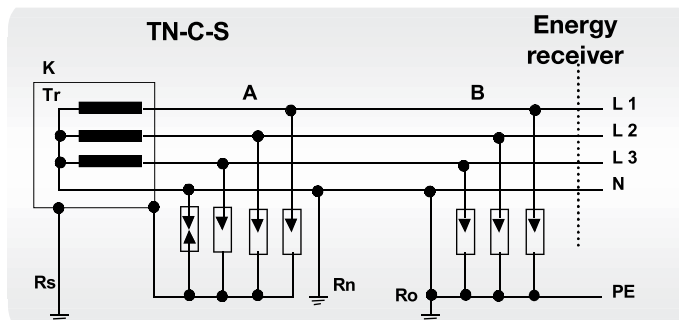

c) TN-C-S the neutral conductor is earthed at the transformer and in other network points

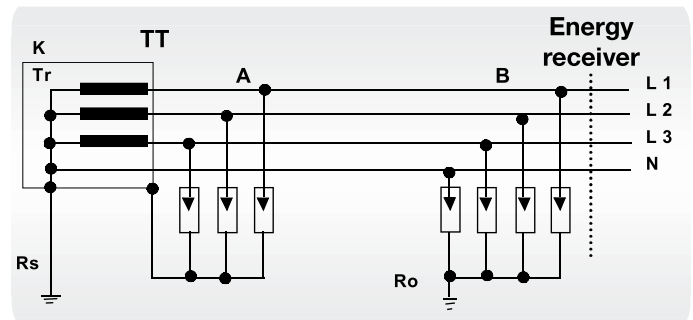

d) TT neutral point of transformer is earthed directly, while the receiver's installation is earthed by a separate earth electrode

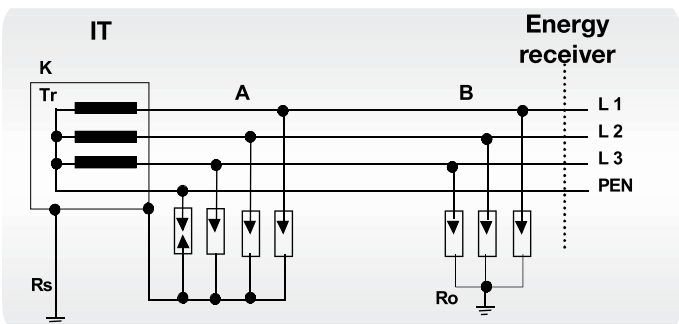

e) IT in this system there is no direct connection of active network parts with earth, while accessible conducting parts of installation elements are earthed

MARKING

- $L_{1,2,3}$ – phase conductor
- N – neutral conductor
- PE – earthing conductor
- PEN – common earthing and neutral conductor
- A – transformer protection Tr
- K – transformer tank
- B – terminal protection
- R_o – SPD earthing
- R_n – earthing of transformer neutral point
- R_s – protective earthing of station



SPD (surge arrester)



Spark gap

SELECTION OF U_c

Taking into account the upper tolerance of system voltage (U_m) at 10% - the maximum continuous operating voltage U_c should be selected as below:

$$U_c \geq 1,1 \times U_m / \sqrt{3}$$

for SPD connected between the phase and neutral conductor

$$U_c \geq 1,1 \times U_m$$

or SPD connected as phase - phase or between the phase and earthing conductor.

The following U_c values can be proposed as standardised (recommended) voltages for 220/380V or 240/400 V networks:

$U_c = 280$ V for phase-neutral conductor and neutral conductor-earth protection (TT and TN systems)

$U_c = 440$ V for phase-phase protection (TT, TN, IT systems)

$U_c = 440$ V for phase-neutral conductor and neutral conductor-earth protection (IT system)

Such parameter SPD practically cover all temporary overvoltage (TOV)¹ hazards that may occur in a low voltage network, simultaneously ensuring the required protection level. If network parameters depart from standard values (e.g., increased voltage or harmonic content), instead of a voltage of $U_c = 440$ V one may use $U_c = 500$ V or 660V, respectively.

PROTECTION LEVEL SELECTION

The SPD protection level is usually determined as the U_p/U_c ratio (U_p - voltage peak value on SPD terminals during flow of nominal discharge current I_n). For different types of sparkless arresters and various manufacturers it is contained in the 3 to 5 limits. When selecting the arresters type attention should be given to the value of this ratio. The lower the U_p/U_c ratio, the greater the insulation protective margin of protected equipment.

SELECTION OF WITHSTOOD ENERGY

The SPD energy absorption capability is in principle defined by the nominal discharge current I_n and pulse current I_{imp} for class I arresters or by I_{max} for class II arresters. Typical nominal discharge current values for class II are 5 kA and 10 kA.

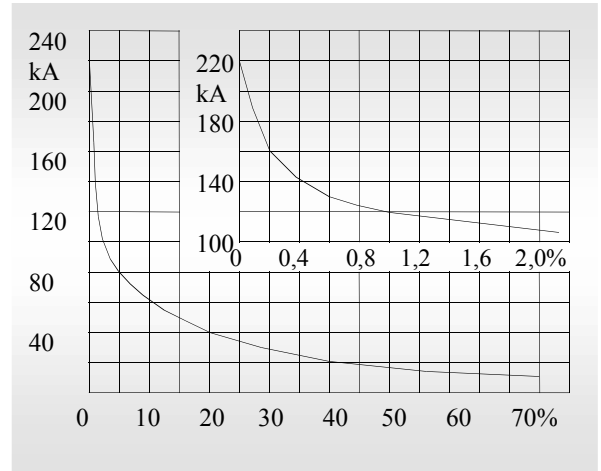

Figure. Lightning current occurrence probability of amplitude greater than values on axis of ordinates

As results from statistical data (Fig. above) 90% of lightning currents have values not greater than 60 kA. In the overhead low voltage network a lightning stroke in the line usually leads to shock of all three phases due to small distances between conductors. Assuming that the lightning current flows in three phases in both directions, the lightning current in the first approximation can be divided by 6. Hence, in over 90% of direct lightning stroke in line cases, the current flowing in an arrester is not greater than 10 kA.

Class II SPD of current: $I_n = 5$ kA and $I_{max} = 25$ kA

should satisfactorily fulfill a protective role in a low voltage network. In regions of large storm hazard (high isoceraunic level) one may recommend application of

Class II SPD of current: $I_n = 10$ kA and $I_{max} = 40$ kA

Special cases, when arresters are used for protection of equipment for storing large energies (e.g. capacitor batteries), should be considered individually as to choice of surge protection means.

⁽¹⁾ „temporary overvoltages”

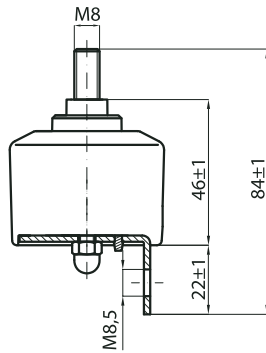

STANDARD TOP ACCESSORIES

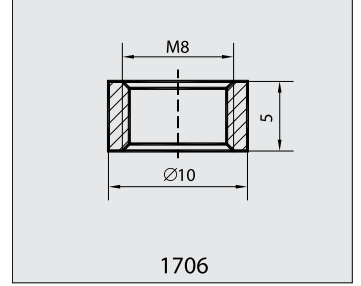
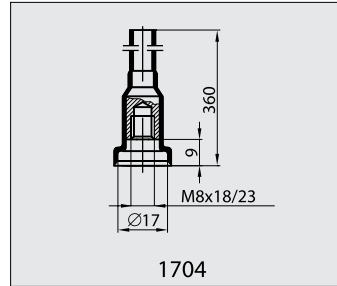
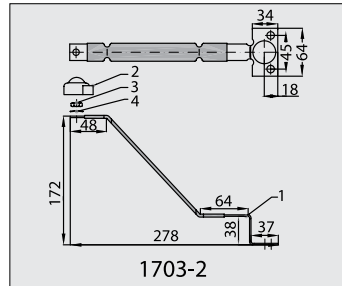
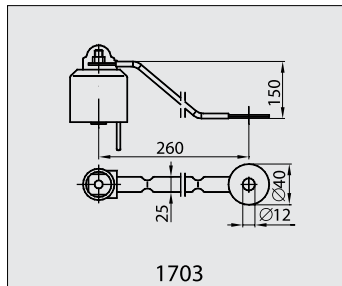
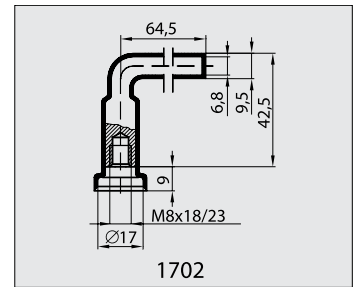
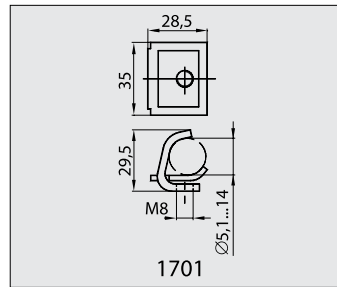

Insulation piercing terminals
from ENSTO

- 1705-1 = SE 45.1
- 1705-2 = SE 46.1
- 1705-3 = SL 9.22

STANDARD BOTTOM ACCESSORIES

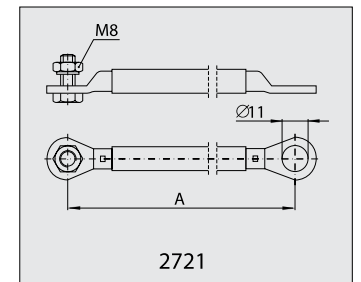
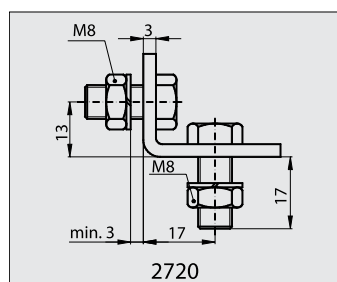
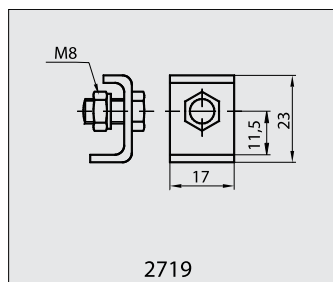
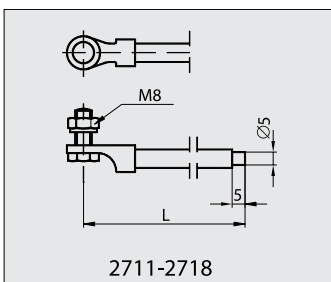

- 2711 – flexible Cu conductor 6 mm², length 500 mm, insulated
- 2712 – flexible Cu conductor 6 mm², length 1000 mm, insulated
- 2713 – flexible Cu conductor 6 mm², length 500 mm, tin-coated
- 2714 – flexible Cu conductor 6 mm², length 1000 mm, tin-coated
- 2715 – flexible Cu conductor 16 mm², length 500 mm, insulated
- 2716 – flexible Cu conductor 16 mm², length 1000 mm, insulated
- 2717 – flexible Cu conductor 16 mm², length 500 mm, tin-coated
- 2718 – flexible Cu conductor 16 mm², length 1000 mm, tin-coated
- 2721 – flexible Cu conductor 16 mm², length 700 mm, insulated

ORDERING EXAMPLE

LOVOS - 5 / 660 + 1701 + 2711

LOVOS - 5 / 660-2 + 1701 + 2719

LOVOS - 10/ 660 + 1701 + 2711

LOVOS - 10/ 660-2 + 1701 + 2719

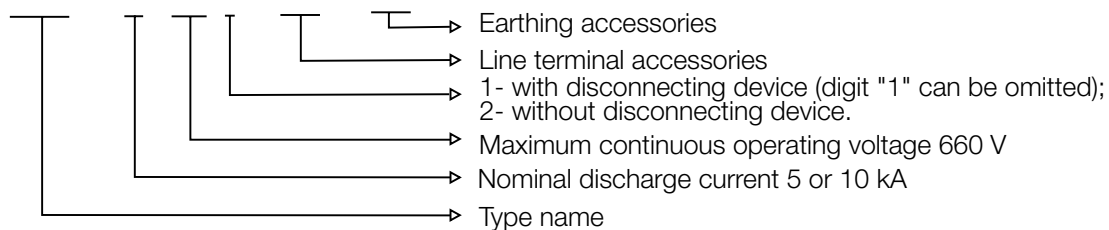

- E.g.:
- 1) Surge arrester type LOVOS – 5/280 – 1 + 1701 + 2711- 50 pcs.
 - 2) Surge arrester type LOVOS – 5/280 + 1701 + 2711 - 50 pcs.



ABB Sp. z o.o.

Branch in Przasnysz

PL 06-300 Przasnysz

ul. Leszno 59

06-300 Przasnysz

Phone: (+48 29) 75 33 218, 75 33 227

Fax: (+48 29) 75 33 329

www.abb.pl