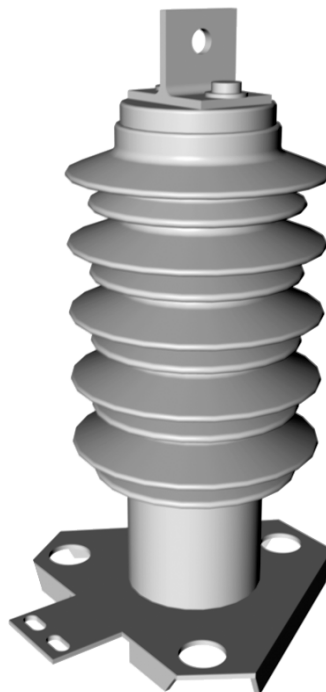

Operating instructions

Publication No. 1HC0031012 AA

Surge arrester Type POLIM[®]-S

With ABB metal-oxide resistors and
silicone housing
Without gaps
For indoor and outdoor use

Mounting and installation, maintenance,
transportation, storage and disposal



Issued by:
ABB Switzerland Ltd.
High Voltage Products
Surge Arresters
Jurastrasse 45
CH-5430 Wettingen 1

Contact information:
Phone: +41 (0)58 585 29 11
Telefax: +41 (0)58 585 55 70
E-Mail: sales.sa@ch.abb.com
Internet: www.abb.com/arrestersonline

We reserve the right to make changes.

We reserve all rights to this document and the object presented within. Reproduction, passing on to third parties or utilisation of the contents is impermissible without our express permission.

© ABB Schweiz AG

Table of contents

1.	ABOUT THIS DOCUMENT	3
1.1.	Validity	3
1.2.	Target group	3
1.3.	Copyright	3
2.	SAFETY	4
2.1.	Symbols and advices	4
2.2.	Basic safety precautions	5
2.2.1.	Product safety	5
2.2.2.	Personnel-related measures	5
2.2.3.	Organisational measures	5
3.	DESCRIPTION	6
3.1.	Intended use	6
3.2.	Structure and function	6
3.3.	Technical data	7
3.3.1.	Technical data on the surge arrester	7
3.3.2.	Usage guidelines	8
3.3.3.	Recommended torques and screw-in depths	8
3.3.4.	Behaviour in fire	8
4.	TRANSPORTATION, UNPACKING AND STORAGE	9
5.	COMMISSIONING	10
5.1.	Safety	10
5.2.	Electrical check before commissioning	10
5.3.	Installation location and protective distance	11
5.4.	Mounting	11
5.4.1.	Mounting grading ring	12
5.4.2.	Transportation during mounting	13
5.4.3.	Installation position	14
5.4.4.	Minimum distances between surge arresters and earth	14
5.4.5.	Earthed installation	14
5.4.6.	Insulated installation	15
5.5.	Earthing	15
6.	MAINTENANCE, UPKEEP	16
7.	DISPOSAL	18

1. ABOUT THIS DOCUMENT

These operating instructions are part of the POLIM[®]-S surge arrester and describe safe and proper use in all phases of operation.

We reserve the right to make changes in the interest of further development.

1.1. Validity

These operating instructions are valid only for the POLIM[®]-S surge arrester.

1.2. Target group

The target group of these operating instructions is professionals in the field of high-voltage technology.

The POLIM[®]-S may only be commissioned and maintained by persons instructed in proper use and handling.

1.3. Copyright

The copyright of these operating instructions belongs to ABB Switzerland Ltd. These operating instructions are to be handled confidentially and are intended solely for mounting, operating and monitoring personnel. They contain regulations and illustrations of a technical nature which may neither be utilized for competitive purposes nor passed on to others. Handing over to third parties is impermissible and liable for compensation.

All rights, including those regarding the translation, are reserved.

2. SAFETY

2.1. Symbols and advices



This is a safety sign. It warns you of the danger of injury and material damage. Follow all measures marked with the safety sign to avoid injuries, death and damage to materials.



This safety sign warns you of the danger of death or serious injury from electric shocks. Follow all measures marked with the safety sign to avoid injuries and death.



This mark indicates that an action is to be performed.

Warnings in these operating instructions indicate special dangers and list measures for prevention of the danger. There are three levels of warning:

Warning word	Meaning
DANGER	Immediate, impending endangerment of your life and health
WARNING	Possible impending endangerment of your life and health
CAUTION	Possible impending danger of light injuries or damage to materials

Warnings are structured as follows:



**WARNING
WORD**

The type and source of danger appear here

Possible consequences, which could occur if the measures are not followed, appear here.

- ⊙ **Impermissible** actions appear here.
- ▶ Measures for avoiding the danger appear here.

2.2. Basic safety precautions

2.2.1. Product safety

The POLIM[®]-S has been constructed using state-of-the-art technology and officially recognised safety-related rules. Danger to life and health of the user or third parties could arise or damage of the POLIM[®]-S and other property could occur while the POLIM[®]-S is in use, however.

- ▶ The POLIM[®]-S is only to be used when it is in technically sound condition, for the intended purpose, and with safety and the possible dangers in mind while observing the operating instructions.
- ▶ Keep the operating instructions intact and fully readable, and store them in such a way that they are accessible to operating personnel at all times.
- ▶ Decommission and replace overloaded or damaged POLIM[®]-S units.

2.2.2. Personnel-related measures

- ▶ Train personnel in professional and safe working with high-voltage technology.
- ▶ Train and instruct personnel in working on the POLIM[®]-S using the operating instructions.
- ▶ Personnel to be trained, broken-in, instructed or provided with general education may only work with the POLIM[®]-S under constant supervision by an experienced high-voltage technology professional.

2.2.3. Organisational measures

- ▶ Observe all safety- and danger-related information regarding the POLIM[®]-S.
- ▶ The safety rules of the owner of the high- and medium-voltage system and all regulations of the respective national safety authorities are to be observed.
- ▶ Only trained and instructed professionals may be authorised.
- ▶ Clearly assign areas of responsibility for working with the POLIM[®]-S, make them known and adhere to them.
- ▶ Only personnel who have read and understood the operating instructions, especially the "Basic safety precautions" section, before beginning work may be allowed to carry out activities with the POLIM[®]-S.
- ▶ Check to ensure that work is being performed in a safety-conscious way with awareness of possible dangers and while observing the operating instructions.

3. DESCRIPTION

3.1. Intended use

The POLIM®-S is a surge arrester intended for use in high- and medium-voltage applications. Surge arresters protect the insulation of high voltage and medium voltage devices against overvoltages which are caused by lightning or switching operations.

The manufacturer is not liable for resulting damages from further, unintended use. The operator is taking this risk only.

3.2. Structure and function

The POLIM®-S surge arrester is constructed from serially connected, non-linear metal-oxide (MO) resistors. These MO resistors have an extremely non-linear resistance property. At the maximum operating voltage of U_c , only a small capacitive current will flow in the mA range. With an increase in voltage, the MO resistors enter a highly-conductive state practically without delay. Thus any further increase in voltage is limited to the specified residual voltage values. After the decline of the overvoltage the arrester immediately turns back to the non- or slightly-conductive state. The MO arrester converts the energy of the surge into heat, which it transfers to the surrounding air.

The stack of MO resistors and connexion equipment is held together with strong loops made of fiberglass-reinforced plastic. The directly moulded silicone housing protects it from all environmental and weather influences. This design has proven to be the best solution in every environment for years.

Thanks to its very high energy absorbing capability and great mechanical strength, the POLIM®-S is especially suited for overvoltage protection of:

- transformers, cables, capacitors
- generators
- locomotives and other apparatuses in railway applications
- other high- and medium-voltage apparatuses and systems

3.3. Technical data

The technical data, dimensions, weights and installation distances are specified in the following documents:

- surge arrester POLIM[®]-S for applications in a.c. systems in the CHHOS/AR3262 pamphlet
- POLIM[®]-S dimensional drawings
- for surge arresters $U_c > 53$ kV, in the corresponding data sheets and dimensional drawings

3.3.1. Technical data on the surge arrester

The rating plate molded into the silicone housing contains the following data:

Data	Meaning
POLIM [®] -S	Type designation
IEC-P-CL .. kA	Rated short-circuit current for 0.2 sec.
f ... Hz	Power system frequencies .. Hz

Additional data is etched in or located on signs.

Data	Meaning
POLIM [®] -S .. N	Complete type designation with specification of the maximum permissible continuous operating voltage U_c
$U_c = ..$ kV	Maximum permissible continuous operating voltage U_c
$U_r = ..$ kV	Rated voltage
$I_n = ..$ kA	Nominal discharge current
IEC-L-CI..	Line discharge class (if specified)
Dat.	Date of manufacture
No. HA ...	Serial number

3.3.2. Application guidelines

The following guidelines apply for the use of POLIM®-S surge arresters:

- "Application guidelines" for medium-voltage systems, pamphlet CHHOS/AR 3257
- "Application guidelines" for railway systems, pamphlet CHHOS/AR 3640

3.3.3. Recommended torques and screw-in depths

The specified values in the following table apply for the steel bolts of strength class 8.8 in aluminum nut threads.

Thread	Position	Maximum torque [Nm]	Minimum screw-in depth [mm]	Maximum screw-in depth [mm]
M8	Grading ring on top end (if present)	15	12	15
M10	Support on grading ring (if present)	30	8	–
M12	Head/foot end	48	17	20
M16	Head end	105	23	25
	Foot end	105	23	50

3.3.4. Behaviour in fire

The silicone housing of the surge arrester is self-extinguishing, and the oxygen index (LOI), measured in accordance with ASTM D 2863 and EN ISO 4589 is greater than 35.

4. TRANSPORTATION, UNPACKING AND STORAGE

Transportation



CAUTION

Surge arresters not secured during transportation

Damage to falling surge arresters.

- ▶ Secure surge arresters against sliding or falling before transportation.
 - ▶ Observe safety precautions printed on the packaging for proper handling during transportation and storage.
-

Unpacking

The surge arresters provided are packaged in stable cardboard boxes or wooden crates. The accessories, packaged in plastic bags, are either included in the carton or wooden crate or supplied separately in case of large quantities.

The surge arresters are supplied with the base plate and HS connexion already installed, if not ordered differently. The routine test reports of final electrical inspection are included in the packaging material.

- ▶ After receiving the shipment, compare the order and delivery documents immediately to check for completeness and accuracy of the shipment. In case of incompleteness or deviations, inform the supplier and shipper immediately.
-



WARNING

Damaged surge arresters

Material damage and personal injury due to the installation and commissioning of damaged surge arresters.

- Do **not** use damaged surge arresters.
 - ▶ Examine shipment immediately to check for damage.
 - ▶ Notify the insurance company, the shipper and the supplier of the damage immediately and create a damage log.
-

Storage

The original packaging materials can be used for storage.

- ▶ Store surge arresters in a well-ventilated, clean room.
- ▶ Remove plastic film to prevent the formation of condensation water.

5. COMMISSIONING

5.1. Safety



DANGER

System uses high voltage

Death, serious bodily harm and damage to the switching gear may result from an electric shock.

- ▶ Allow only authorised professionals to perform work on the surge arrester.
 - ▶ Observe the safety rules of EN 50110-1 before working on the system:
 - Disconnect the system from the power supply.
 - Secure the system against being switched on again.
 - Ensure that the system is de-energised.
 - Earth the system and short-circuit it.
 - Cover or cordon off neighbouring energised parts.
-

5.2. Electrical check before commissioning

Each surge arrester is tested by the manufacturer. The routine test report is included with the packaging. Additional electrical testing before commissioning is not necessary.

5.3. Installation location and protective distance



DANGER

Danger of fire and injury via arc with overloading of the surge arrester

Ignition of flammable materials by an arc and flying burning parts.

- ▶ Do not store flammable materials near the surge arrester.
- ▶ When working near the surge arrester, do not wear easily flammable clothing.

Surge arresters only protect high- and medium-voltage apparatuses when they are located within the protective distance. The protective distance is only a few meters.

- ▶ Always mount surge arresters as close as possible to the apparatus to be protected within the protective distance. The length of the connexion cables is decisive here.
- ▶ In cases of doubt, calculate the protective distance according to the formulas in the "Application guidelines".

5.4. Mounting



CAUTION

Incorrect system voltage

Damage to the switching gear and the surge arrester.

- ⊙ Do **not** use surge arresters intended for a.c. systems in d.c. systems.
- ▶ Observe the "Application guidelines" from ABB Switzerland Ltd.
- ▶ Before mounting, ensure that the characteristic data on the rating plate of the surge arrester matches the requirements of the power system.
- ▶ Ensure that system voltage applied at the terminals of the arrester does not exceed the maximum permissible continuous operating voltage of the surge arrester.

The head end is generally intended for connexion to the high voltage and the foot end/floor plate is generally to be connected to the system ground.

The base or foundation for the surge arrester must be flat, clean and suitable for the loads that arise.

The following materials made of stainless or galvanised steel are to be provided by the customer:

- bolts
 - foundation bolts
 - nuts
 - bolt locks
 - any required balancing washers
- ▶ Carefully clean contact surfaces before mounting and lubricate with acid-free contact grease.
- ▶ Ensure selection of suitable material pairs.

5.4.1. Mounting grading ring

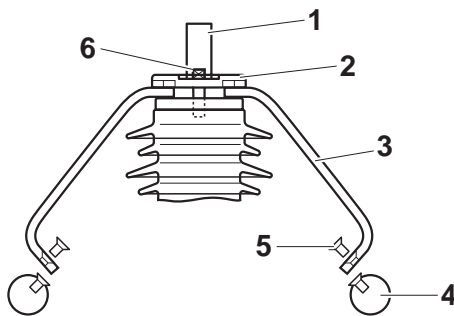

If your surge arrester has a grading ring, you must mount it.

- ▶ Ensure that the surge arrester cannot topple over.
- ▶ Place grading ring (4) over the surge arrester with mounting holes toward the top.
- ▶ Loosen threaded rod M8 (6), if present, in the cover (2) with a hexagonal wrench.
- ▶ Screw out connexion bolt (1) approx. 11 mm with a fork wrench.
- ▶ Lift cover.
- ▶ Place the three supports (3) of the grading ring into the intended cut-outs between the cover (2) and surge protector.
- ▶ Screw in connexion bolt (1) with a fork wrench, but do not tighten it yet.
- ▶ Screw grading ring (4) onto the supports with countersunk screws M10 (5).
- ▶ Tighten connexion bolts (1) to a torque of 105 Nm.
- ▶ Tighten countersunk screws (5) at the grading ring to a torque of 30 Nm.
- ▶ Tighten threaded rod M8 (6), if present, in the cover (2) to a torque of 15 Nm.

5.4.2. Transportation during mounting

Depending on weight and installation location of the surge arrester, a crane may be necessary for mounting. The crane ropes can be fastened in the following ways, depending on the surge arrester model:

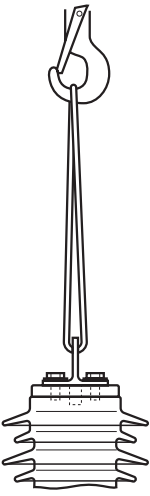
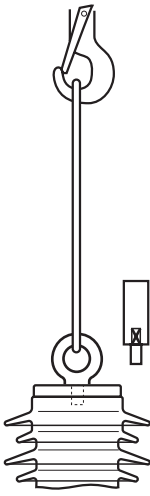
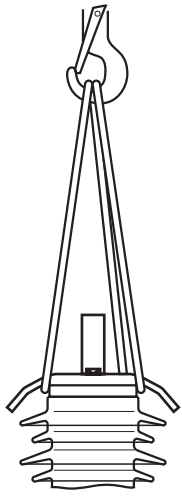
Fastening to accessories	Fastening via ring bolt (if not possible to accessories)	Fastening to grading ring (if present)
		
Figure 1	Figure 2	Figure 3

Fastening to accessories

- ▶ Hook rope as shown in Figure 1.

Fastening via ring bolt

- ▶ Remove top accessories from surge arrester.
- ▶ Screw ring bolt into threaded hole M16x25.
- ▶ Hook rope as shown in Figure 2.

Fastening to grading ring

- ▶ Hook three ropes in the three supports of the grading ring and the hook of the crane as shown in Figure 3.

5.4.3. Installation position



CAUTION

Deposits on the undersides of sheds

Conductivity of deposits hinders protective function of the POLIM®-S.

- ▶ Always mount surge arresters in such a way that the sheds point downward.

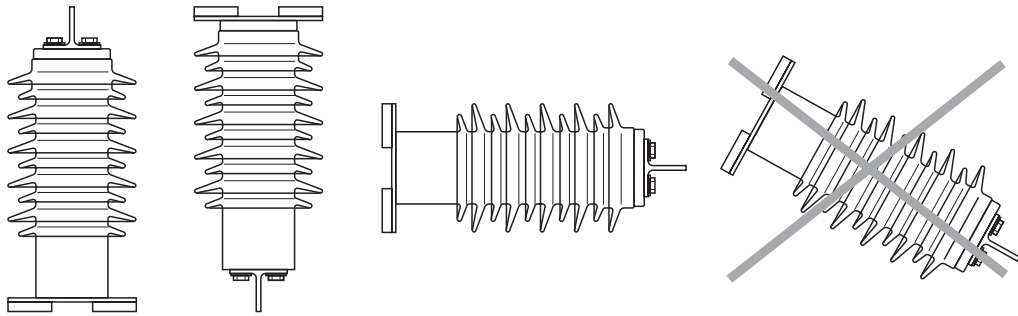

5.4.4. Minimum distances between surge arresters and earth

The minimum permissible distances between the surge arresters and the earth are specified on the data sheets supplied with the offer or order confirmation. The values are based on calculations for unfavourable conditions and include safety margins.

- ▶ Observe national regulations and the rules of the system owner.

5.4.5. Earthed installation

- ▶ Bolt surge arresters directly to the earthed frame or foundation using centring washers, if no surge counter or milliameter is used.
- ▶ Connect earth connexion of the surge arrester to its base plate tab.

5.4.6. Insulated installation

If surge counters and/or milliammeters were supplied, the POLIM[®]-S surge arrester is to be mounted insulated.

- ▶ Mount surge arresters with the included loose insulators made of cast resin on the earthed frame or foundation according to the dimensional drawing.
- ▶ Mount surge counters/milliammeters according to the respective mounting instructions.
- ▶ If surge counters/milliammeters are mounted with separate current gauges, connect the earth connexion at the base plate tab of the surge arrester.

Surge counters/milliammeters with analogue display

Surge counters/Milliammeters with analogue display are connected in series to the surge arrester between the floor plate and the earth connexion.

- ▶ Attach cable connexion of the surge counter/milliammeter to the base plate tab of the surge arrester.
- ▶ Select a cable or conductor for the connexion cable with the same diameter and material as used for earth connexion.
- ▶ Connect the earth connexion to the earth tab of the surge counter/milliammeter.

5.5. Earthing

- ▶ Observe national regulations and the requirements of the system owner.
- ▶ Connect surge arresters to the system earth via the shortest path.
- ▶ Observe recommended minimum diameters:

Copper	dia. 80 mm ²
Aluminum	dia. 150 mm ²

6. MAINTENANCE, UPKEEP



DANGER

System uses high voltage

Death, serious bodily harm and damage to the switching gear may result from an electric shock.

- ▶ Allow only authorised professionals to perform work on the surge arrester.
 - ▶ Observe the safety rules of EN 50110-1 before working on the system:
 - Disconnect the system from the power supply.
 - Secure the system against being switched on again.
 - Ensure that the system is de-energised.
 - Earth the system and short-circuit it.
 - Cover or cordon off neighbouring energised parts.
-

The surge arresters do not contain wearing parts and are therefore maintenance-free. Replacement parts are not needed.

Replacement after overloading or damages caused by animals

Overloading during operation can lead to damaging (e.g. traces of fire, fractures) of the surge arrester from arcs.

Minimal animal bites on the sheds of the silicone housing (e.g. by birds, martens, mice etc.) do not hinder the functioning of the surge arrester. Heavy bites do reduce the insulation capacity of the silicone housing, however.



CAUTION

Damage to the surge arrester

Damaged surge arresters no longer protect the switchgear.

- ▶ Check the surge arresters visually on a regular basis to ensure that they are in sound condition.
 - ▶ Replace damaged surge arresters.
-
- ▶ Keep a small percentage of installed surge arresters in reserve.

Cleaning in case of heavy pollution

Thanks to the hydrophobicity of the silicone housing, normal pollution does not affect the insulation capacity of the housing. If pollution exceeding this is present (heavy deposit layer) the surge arrester can be cleaned.



CAUTION

Solvents and abrasive equipment

Damage to the silicone housing.

- ⊘ Do **not** use cleaning agents containing solvents or abrasive equipment for cleaning.
 - ▶ Clean surge arresters with clean, warm water and soft, lint-free cloths.
-

7. DISPOSAL

POLIM®-S surge arresters are environmentally-friendly products which must be disposed of based on the respective applicable regional regulations in an environmentally-friendly manner. The materials should be given up for recycling.

Constituent components are:

- silicone rubber (not halogenated) for the external insulation
- mounting sections and other parts made of aluminium
- metal-oxide varistors
- fibreglass-reinforced plastic lugs
- steel mounting hardware

Silicone rubber (not halogenated)

The silicone rubber can break down into SiO_2 and CO_2 , thus uncovering the encased metal-oxide varistors.

Metal-oxide varistors

The metal-oxide varistors are sintered ceramics consisting up to 90% of ZnO . The following additions are also contained within:

- percent by weight over 1%: Bi_2O_3 and Sb_2O_3 , which are considered to be dangerous substances according to EU ordinances
- percent by weight between 0.1 and 1%: NiO and Cr_2O_3 , which are considered poisonous and dangerous materials pursuant to EU guideline 91/689/EEC

Metal-oxide varistors are coated with a thin glass coating containing lead-oxide (< 0.1% of the weight).

The substances are present as an oxide in metal-oxide varistors. A wash-out test in accordance with an EPA specification (Federal Register/vol. 45, No 98 /Rules and regulations) has shown that the sintered metal-oxide varistors can be disposed of as industrial waste without infringing on EEC guidelines.

No danger to personal health or the environment is present during normal operation.