

Surge Arresters

POLIM-D Datasheet





Surge Arrester POLIM-D

- Manufactured by ABB Switzerland Ltd.
- Designed and tested according to IEC 60099-4, Edition 2.1, 2006-07, §10
- Metal oxide surge arrester without spark gaps
- For AC systems up to 36 kV
- Direct moulded silicone housing, grey color
- Made in Switzerland

Technical Data

- Nominal discharge current I_n 8/20 μ s 10 kA pk
- Line discharge class 1
- High current operating duty test I_{hc} 4/10 μ s acc. to LD1 100 kA pk
- Long duration current impulse acc. to LD1 250 A / 2000 μ s
- Short circuit rating I_s 50 Hz 20 kA rms for 0.2s
- Classification according to IEEE (ANSI) C62.11 distribution heavy duty
- The thermal stability of the MO-surge arrester is proved in the operating duty test with the application of one high current impulse $I_{hc} = 100$ kA, which gives an energy input of 3.6 kJ/kV_{uc}

Power frequency voltage versus time characteristic (TOV) with prior application of I_{hc} (4/10 μ s) = 100 kA

$$t = 1 \text{ s} \Rightarrow U_{TOV} = 1.325 \times U_c$$

$$t = 3 \text{ s} \Rightarrow U_{TOV} = 1.300 \times U_c$$

$$t = 10 \text{ s} \Rightarrow U_{TOV} = 1.275 \times U_c$$

Mechanical loads:

- torque moment 50 Nm
 - tensile strength 625 N
 - Bending moment MPSSL 200 Nm
- (Moment resulting from the force applied in the type test on the longest housing of POLIM-D)

Weather ageing: tested according to series A (1000 h salt fog) and series B (5000 h cyclic test)

Service conditions

- Ambient air temperature (for higher values contact manufacturer) -60 to +40 °C
- Altitude (for higher values contact manufacturer) up to 1800 m
- Frequency 50/60 Hz

Application

Protection of medium voltage AC systems against both, multiple atmospheric and switching overvoltages. Suitable for instance for the protection of overhead lines and distribution transformers (pole mounted) as well as for other medium voltage equipment. For indoor and outdoor installation. The pollution resistant and mechanical strong design, combined with proven long term stability ensures a safe and reliable performance in the system. For selection and application principles refer to our application guidelines.

Electrical data for POLIM-D

U_c Continuous operating voltage	U_r Rated voltage	Residual voltage (U_{res}) in kV peak at a specified impulse current									
		wave 1/ ... μ s at		wave 8/20 μ s at					wave 30/60 μ s at		
		5 kA peak	10 kA peak	1 kA peak	2.5 kA peak	5 kA peak	10 kA peak	20 kA peak	125 A peak	250 A peak	500 A peak
4	5.0	14.5	16.0	11.7	12.4	13.1	14.0	15.9	10.4	10.8	11.1
6	7.5	21.7	24.0	17.5	18.5	19.6	21.0	23.9	15.6	16.1	16.6
8	10.0	28.9	32.0	23.3	24.7	26.1	28.0	31.8	20.8	21.5	22.2
10	12.5	36.1	39.9	29.1	30.8	32.6	35.0	39.8	25.9	26.8	27.7
12	15.0	43.3	47.9	34.9	37.0	39.1	42.0	47.7	31.1	32.2	33.2
14	17.5	50.5	55.9	40.7	43.2	45.6	49.0	55.7	36.3	37.5	38.8
16	20.0	57.7	63.9	46.5	49.3	52.1	56.0	63.6	41.5	42.9	44.3
18	22.5	64.9	71.9	52.3	55.5	58.6	63.0	71.6	46.7	48.2	49.8
20	25.0	72.1	79.8	58.1	61.6	65.1	70.0	79.5	51.8	53.6	55.3
22	27.5	79.4	87.8	64.0	67.8	71.7	77.0	87.4	57.0	59.0	60.9
24	30.0	86.6	95.8	69.8	74.0	78.2	84.0	95.4	62.2	64.3	66.4
26	32.5	93.8	103.8	75.6	80.1	84.7	91.0	103.3	67.4	69.7	71.9
28	35.0	101.0	111.8	81.4	86.3	91.2	98.0	111.3	72.6	75.0	77.5
30	37.5	108.2	119.7	87.2	92.4	97.7	105.0	119.2	77.7	80.4	83.0
32	40.0	115.4	127.7	93.0	98.6	104.2	112.0	127.2	82.9	85.7	88.5
34	42.5	122.6	135.7	98.8	104.8	110.7	119.0	135.1	88.1	91.1	94.1
36	45.0	129.8	143.7	104.6	110.9	117.2	126.0	143.1	93.3	96.4	99.6

Housing Selection Table for POLIM-D (Type designations)

U_c	Housing	01	02	03	04	05	06	07	08	09	10	11
	Creepage	153 mm	248 mm	306 mm	375 mm	460 mm	506 mm	610 mm	715 mm	844 mm	1101 mm	1311 mm
4		04-01	04-02									
6		06-01	06-02									
8				08-03	08-04							
10				10-03	10-04	10-05	10-06					
12				12-03	12-04	12-05	12-06					
14						14-05	14-06	14-07	14-08			
16						16-05	16-06	16-07	16-08			
18						18-05	18-06	18-07	18-08	18-09		
20								20-07	20-08	20-09		
22								22-07	22-08	22-09	22-10	
24								24-07	24-08	24-09	24-10	
26										26-09	26-10	26-11
28										28-09	28-10	28-11
30										30-09	30-10	30-11
32											32-10	32-11
34											34-10	34-11
36											36-10	36-11

Housing data for POLIM-D

Dimensions (in mm)

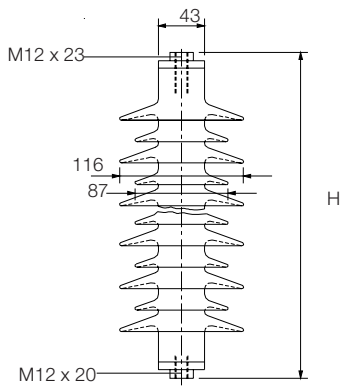

Housing 02, 04, 06, 08, 09, 10, 11

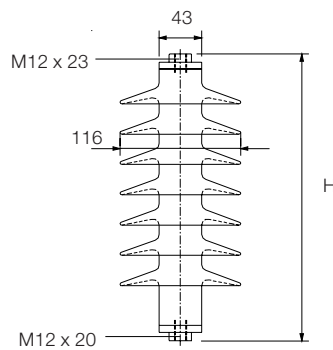

Housing 01, 03, 05, 07

Minimum clearances

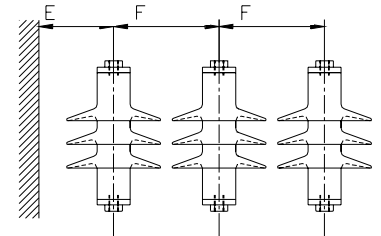

Housing	Creepage distance mm	Flashover distance mm	Recommended clearances		Height H mm	Weight kg	Insulation withstand voltage of empty housing	
			E min mm	F min mm			BIL 1.2/50 μ s kV	50 Hz, 60 s wet kV rms
01	153	121	90	120	144	≤ 0.8	78	20
02	248	136	90	120	144	≤ 0.9	88	23
03	306	170	157	175	191	≤ 1.2	110	28
04	375	182	157	175	191	≤ 1.4	118	35
05	460	217	225	240	239	≤ 1.6	140	38
06	506	229	225	240	239	≤ 1.8	148	40
07	610	264	293	306	286	≤ 2.2	170	50
08	715	283	293	306	286	≤ 2.5	180	53
09	844	328	361	371	334	≤ 3.1	213	63
10	1101	420	428	437	429	≤ 3.5	273	75
11	1311	514	428	437	518	≤ 4.1	296	87

The manufacturer reserves the right to change technical data or design without prior notice

Old and New Type Designation for POLIM-D

Old designation	New equivalent designation
POLIM-D 4 N	POLIM - D 0 4 - 0 1
6 N	POLIM - D 0 6 - 0 1
8 N	POLIM - D 0 8 - 0 3
10 N	POLIM - D 1 0 - 0 3
12 N	POLIM - D 1 2 - 0 3
14 N	POLIM - D 1 4 - 0 5
16 N	POLIM - D 1 6 - 0 5
18 N	POLIM - D 1 8 - 0 5
20 N	POLIM - D 2 0 - 0 7
22 N	POLIM - D 2 2 - 0 7
24 N	POLIM - D 2 4 - 0 7
POLIM-D 4 L	POLIM - D 0 4 - 0 2
6 L	POLIM - D 0 6 - 0 2
8 L	POLIM - D 0 8 - 0 4
10 L	POLIM - D 1 0 - 0 6
12 L	POLIM - D 1 2 - 0 6
14 L	POLIM - D 1 4 - 0 8
16 L	POLIM - D 1 6 - 0 8
18 L	POLIM - D 1 8 - 0 9
20 L	POLIM - D 2 0 - 0 9
22 L	POLIM - D 2 2 - 1 0
24 L	POLIM - D 2 4 - 1 0
30 L	POLIM - D 3 0 - 1 1
36 L	POLIM - D 3 6 - 1 1

POLIM-D 04 - 01

U_c = continuous operating voltage

Housing size

POLIM-D Standard Accessories

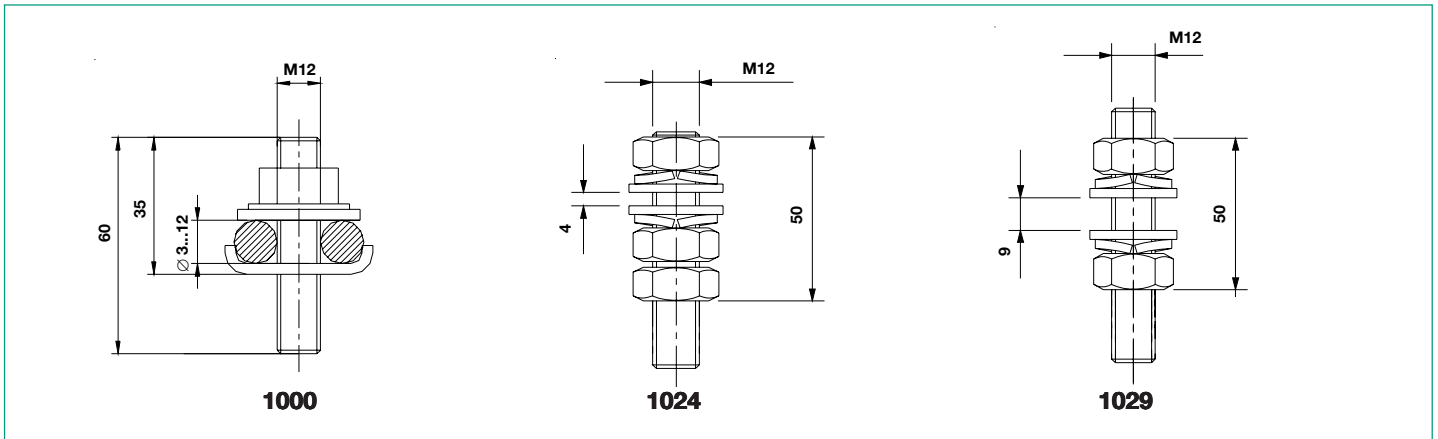

Top Accessory

- 1000** Clamp type connectors
- 1024** Threaded pin M12 with 3 hexagonal nuts and spring washers
- 1029** Threaded pin M12 with 2 hexagonal nuts and spring washers

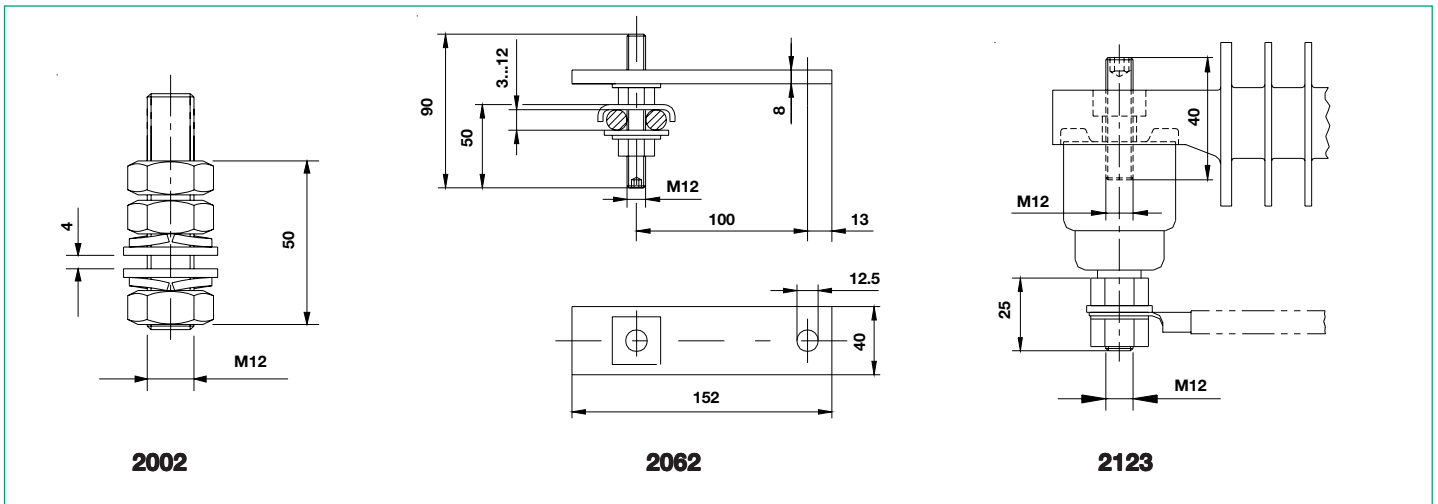

Bottom Accessory

- 2002** Threaded pin M12 with 3 hexagonal nuts and spring washers
- 2062** Fixing plates (M12) acc. to NEMA
- 2123** Insulating bracket with disconnecter



ABB Switzerland Ltd.

High Voltage Products
Surge Arresters
Jurastrasse 45
CH-5430 Wettingen/Switzerland

Tel. +41 58 585 29 11
Fax +41 58 585 55 70
Email: sales.sa@ch.abb.com
www.abb.com/arrestersonline