

**WS5 Connector**

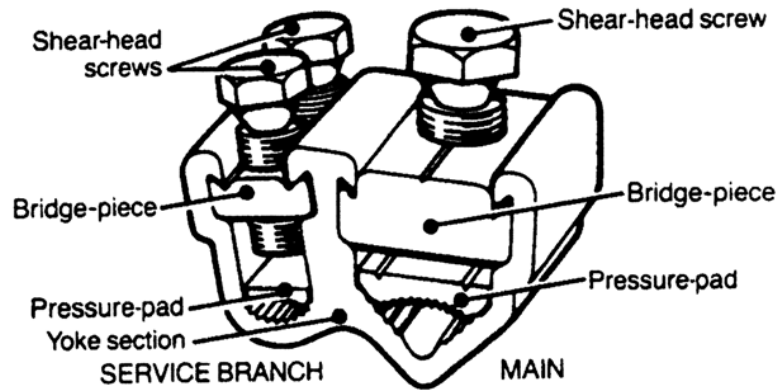

Registered Design No. 993196

**Principal Application**

Service branch connections from stranded sector shaped mains conductors

**Range**

Connector reference	Core c.s.a. (mm <sup>2</sup> )				Approx Unit Wt. (grammes)
	Main		Service Branch		
	min.	max.	min.	max.	
WS5	400	500	16*	95	225

\*NOTE: For small section conductors see technical data overleaf

The Hepworth WS5 connector has been designed to accommodate solid or stranded service conductors to a maximum of 95mm<sup>2</sup>, from four core stranded sector shaped mains conductors in the range 400-500mm<sup>2</sup>.

The connector employs the proven shear-head screw principle to ensure that a consistent and reliable connection is achieved. Fitting is completed by the use of orthodox hand tools only, and no specialised equipment or techniques are required.

Each connector is supplied in a sealed pack together with fitting instructions, details of which are included in the technical data overleaf.

**WS5 Connector**

**Secondary Applications**

The WS5 can accept stranded circular conductors, to BS6360 (copper) and BS6791 (aluminium) in the main and/or branch sides of the connector.

**Range**

Connector reference	Core c.s.a. (mm <sup>2</sup> )			
	Main		Service Branch	
	min.	max.	min.	max.
WS5	240	400	16	70

**Physical Dimensions**

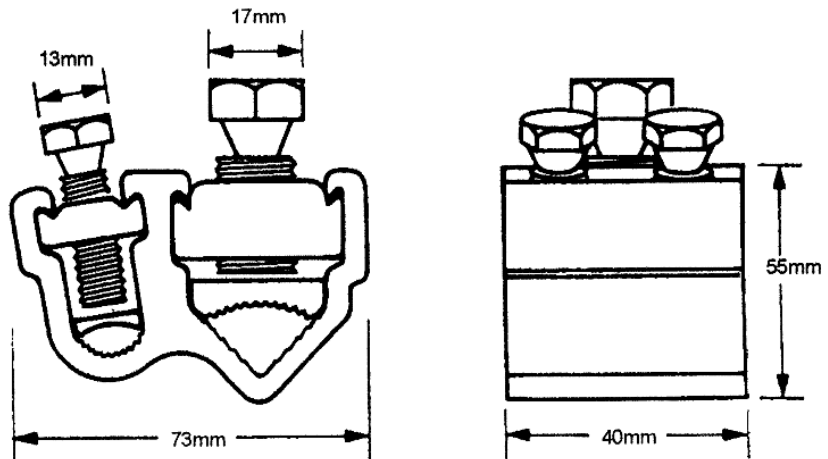

**Material**

Aluminium Alloy

**Fitting Instructions**

Separate the main cable cores sufficiently to allow the yoke section to be fitted around the conductor and strip the insulation from the core equal to the connector length plus 10mm. Thoroughly abrade the exposed conductor and loosely assemble the connector around the core by fitting the bridge piece, inserting the pressure pad and tightening the mains screw until the connector is positively located. Cut the branch conductor to length, strip the insulation to suit, then thoroughly abrade and assemble the core into the connector by fitting

the bridge piece and pressure pad, and tightening down the service screws to hold the conductors in position. Complete the operation by tightening down the mains screws until the head shears, then finally tightening the service screws consecutively, one turn at a time, until both heads are sheared.

It is suggested that conductors below the minimum range requirement of 16mm<sup>2</sup> are doubled and, if needed, redoubled to achieve the required cross sectional area and, if copper conductors are to be jointed, they should be wrapped in brass gauze in order to improve the electrical stability of the interlace connection.