

UT15 Connector

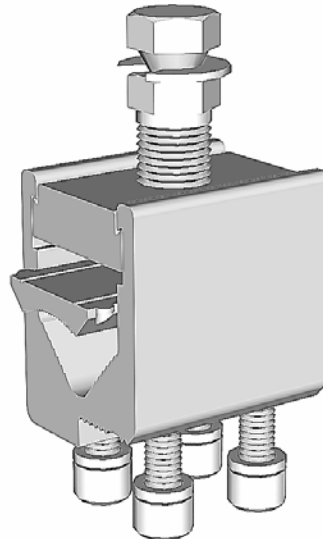

Principle Application

Termination of stranded sector shaped aluminium/copper conductors.

Range

150-300mm²

The **Hepworth UT** range of mechanical connectors is designed as an alternative to the traditional flat busbar termination with the following advantages: -

1. With the aid of shear torque screws, to secure the conductor the necessary consistency between connections can be achieved without the use of specialised tooling.
2. The full connection can be carried out using basic hand tools.
3. The busbar face of the connector provides a more consistent area of contact with the additional advantage, in the case of aluminium busbars, of surface oxide rupture and penetration under pressure. *

*Note: With tinned copper busbars, the tin acts effectively as a bi-metallic interface and the soft tin surface layer yields under pressure to the surface ridges of the connector, deforming around the penetrating aluminium as a corrosion-resistant contact.

UT15 Connector

Physical Dimensions (mm)

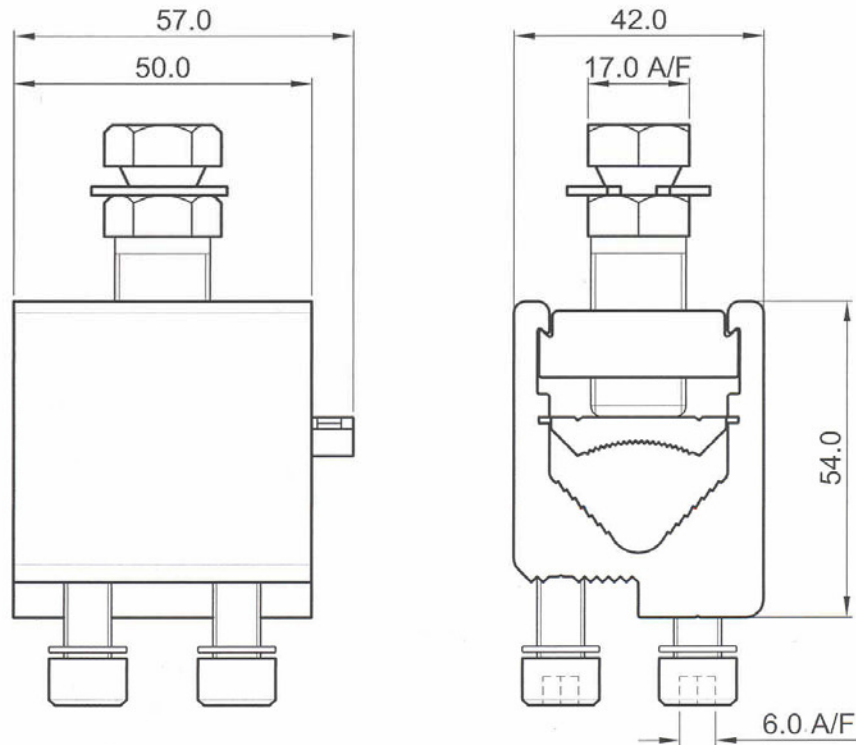

Fitting Instructions

Set the conductor to the required position, cut to length and strip the insulation equal to the connector length plus 5mm. Thoroughly abrade the exposed conductor and clean, or if necessary, abrade the busbar in the contact area (eg. in the case of aluminium). Assemble the connector around the conductor and tighten the screw sufficiently to secure to the conductor, temporarily, but do not shear the screw head at this stage. Offer the connector to the busbar and assemble, adjusting the position of the connector on the cable if necessary. Carefully tighten the double-headed screw, using the outer screw head only, until the head shears, ensuring that the socket does not engage or foul the lower hexagon. Finally check for correct alignment of the conductor and tighten the cable clamping screw until the head shears.

NOTES

1. The connector is normally supplied with disc-spring type washers for the busbar clamping screw but if the busbar is less than 8mm (or 5/16" thick), suitable spacer washers must be used to achieve a nominal thickness of 8mm or 5/16".
2. If copper cable is to be jointed it should be wrapped in brass gauze to improve the electrical stability of the interface connection.