

Mains service
connectors—single
service

MECHANICAL CONNECTORS

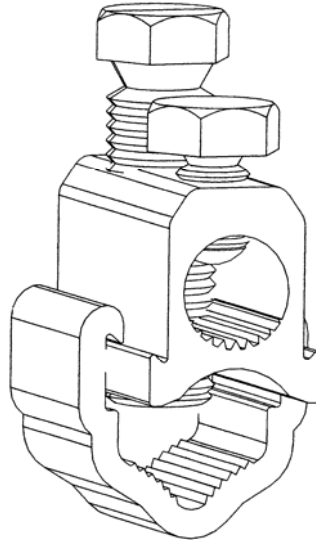

UMS95/S, UMS185/S & UMS300/S Connectors



Principle Application

For LV mains service jointing of sector/round, stranded/solid, aluminium/copper conductor cores.

Range

Connector Ref	Mains (mm ²)		Service (mm ²)		Approx Unit Weight (gms)
	Min	Max	Min	Max	
UMS95/S	25	95	10*	70	
UMS185/S	50	185	10*	70	
UMS300/S	70	300	10*	70	

Note: For jointing other core configurations/sizes please contact Sicame Technical Dept

The **Hepworth UMS95/S** range of mains service connectors accommodates an extensive range of LV mains cable style and sizes.

The connector utilises the proven shear head, direct acting bolts (plated) thereby removing the need for pressure plates.

The plated bolts, combined with a standard plated yoke section, allow for the jointing of mains copper conductor cores without the need for conventional brass gauze.

Note: For the jointing of CNE strands add the suffix 'N' to the end of the product code, pressure pads will then be included.

**UMS95/S, UMS185/S & UMS300/S
Connectors**

Physical Dimensions

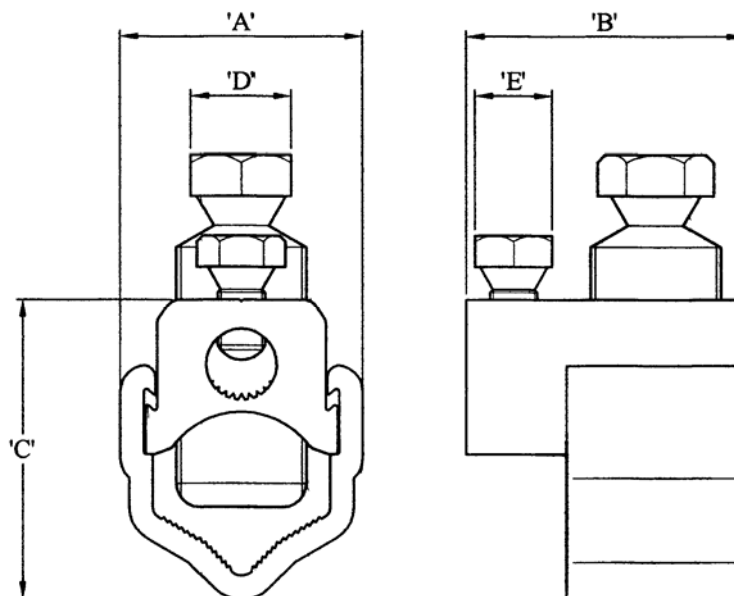

Connector Reference	Dimensions (mm)				
	A	B	C	D	E
UMS95/S	26.0	40.0	36.5	13 A/F	13 A/F
UMS185/S	35.0	46.0	44.5	17 A/F	13 A/F
UMS300/S	41.0	49.0	51.0	17 A/F	13 A/F

Material

Aluminium Alloy

Copper Alloy (Service Shear Screw)

Test Specification

Designed to meet the requirements of Engineering Recommendation C79 and IEC 1238-1.

Note: Stranded service conductor less than 10mm² should be doubled and re-doubled, where necessary, to achieve a satisfactory cross section area.