

Service branch or parallel
straight through
connector

MECHANICAL CONNECTORS

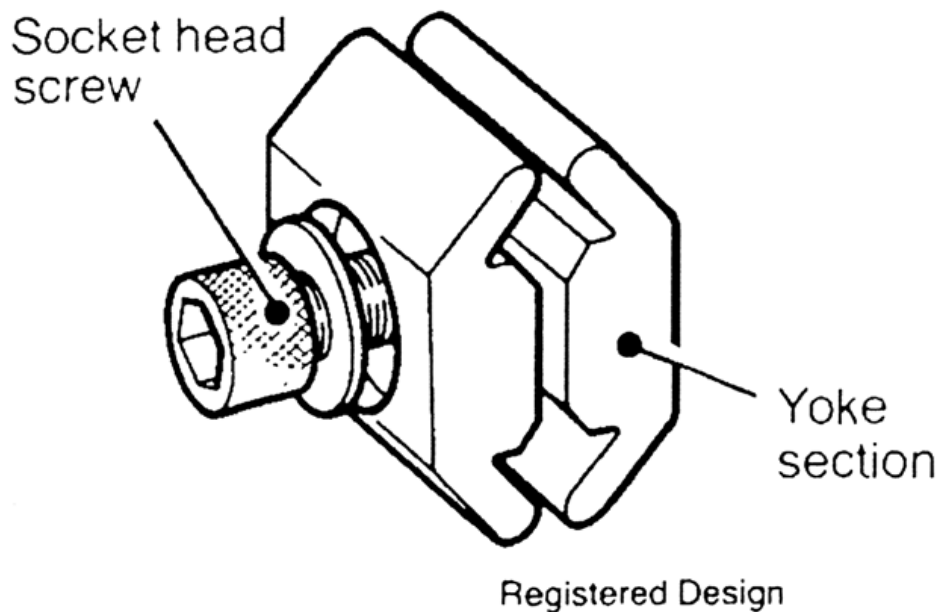

P1 Connector



Principle Application

All designs of service cable up to 35 mm² c.s.a.

NOTE: For small section conductors see technical data overleaf.

The Hepworth P1 connector is a well established multi-purpose service connector for branch or straight-through connections, used extensively in general service applications, including street lighting.

The compact size assists in the construction of closely profiled joints and its versatility allows the connection of two, three and four core sector shaped or circular conductors of any materials up to a maximum cross-sectional area of 35 mm².

Each connector is supplied complete with brass gauze as standard, in a sealed polythene bag. Details of fitting procedures are included with the technical data overleaf.

NOTE: If required the P1 connector can also be supplied with a 13mm A/F hexagon head set screw
Product code P1H.

Service branch or parallel
straight through
connector

MECHANICAL CONNECTORS

P1 Connector

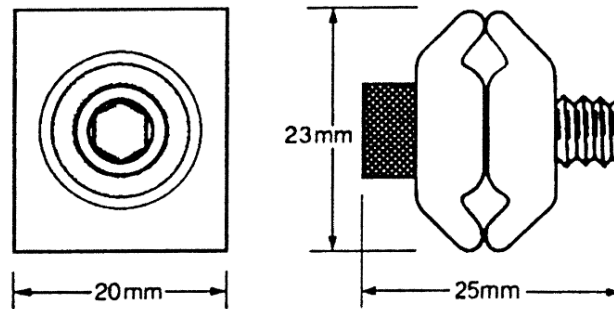

Material

Aluminium Alloy

Product Weight

2.3 KG per 100 (nominal)

Fitting Instructions

Cut the service cables to length and remove the insulation using the connector as a guide. Thoroughly abrade the exposed conductors and loosely fit the connector, ensuring that the conductors are correctly aligned. Fully tighten the socket head screw using a 3/16" A/F hexagonal drive.

Stranded conductors below 16 mm² should be doubled and re-doubled and, if copper conductors are to be jointed, they should be wrapped in brass gauze. This not only improves the electrical stability of the interface connection, but also helps to contain the strands to prevent splaying.