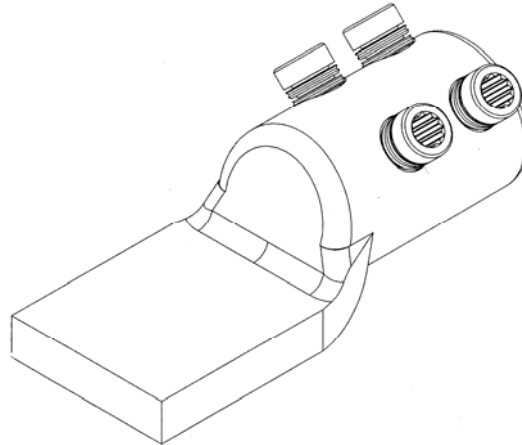

**ML7 Connector****Principle Application**

Termination of solidal/stranded, aluminium/copper circular conductor cores.

**Range**

Product Reference	Core c.s.a. (mm <sup>2</sup> )		Stud Size (mm)
	Min	Max	
ML7	480	740	-
ML7-4 x 8			4 x M8
ML7-4 x 10			4 x M10
ML7-20			M20

Note: For jointing other core configurations please contact Sicame Technical Dept

The **Hepworth ML7** mechanical lugs are manufactured from an aluminium forging, thereby providing an integral moisture block. The lugs utilise the patented 'universal' range taking shear bolts.

**ML7 Connector**

**Physical Dimensions**

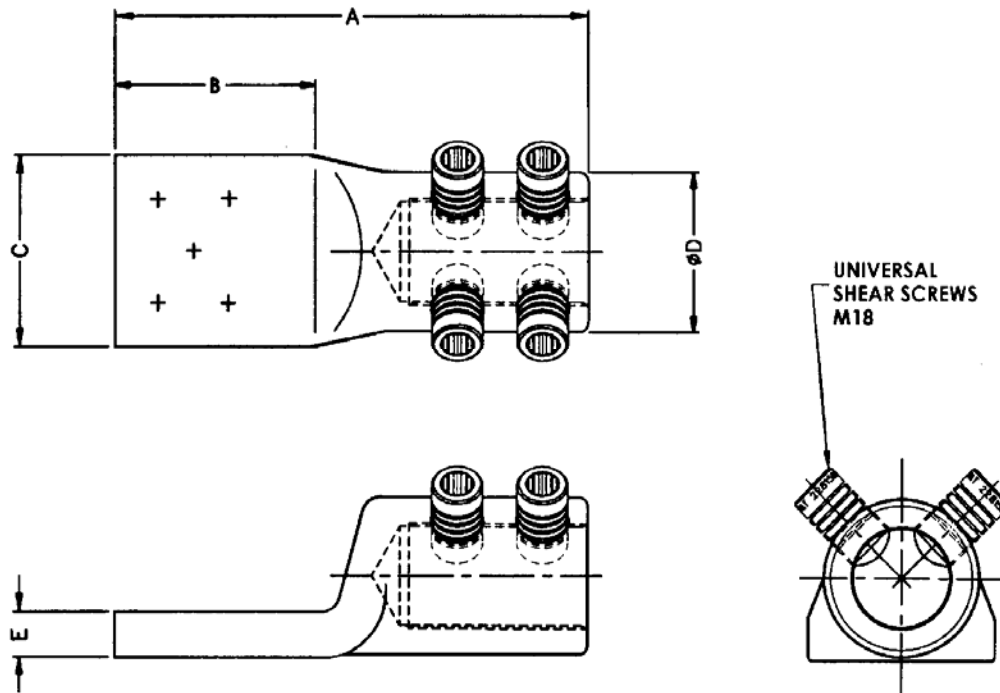

Product Reference	Dimensions (mm)					Stud Size (mm)
	A	B	C	ØD	E	
ML7	166	70	65	54	16	-
ML7 - 4 x 8	166	70	65	54	16	4 x M8
ML7-4 x 10	151	55	65	54	16	4 x M10
ML7 - 20	166	70	65	54	16	M20

**Material**

Aluminium Alloy

**Fitting instructions**

1. Strip insulation from each core equal to the depth of the bore guide + 5mm.
2. Thoroughly abrade exposed conductors. (See note)
3. Fully insert core within the barrel of the connector.
4. Tighten the universal bolts consecutively one turn at a time until all the heads have sheared.

Note: When jointing copper conductor wrap the supplied brass gauze around the core prior to installation.