

ML Connectors

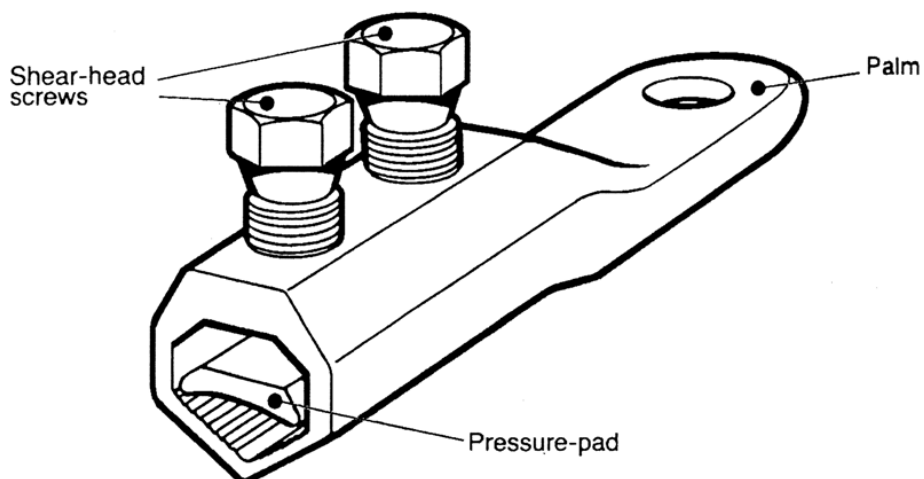

Principle Application

Termination of sector shaped stranded or solid cored conductors.

Range

Product Reference	Core c.s.a. (mm ²)		Stud Size		Approx Unit Wt. (gms)
	min.	max.	metric	imp	
ML1-12	50	95	M12	½"	110
ML1-16	50	95	M16	⅝"	110
ML2-12	120	185	M12	½"	167
ML2-16	120	185	M16	⅝"	167
ML3-12	240	300	M12	½"	300
ML3-16	240	300	M16	⅝"	300
ML3-20	240	300	M20	¾"	300
ML4	400	500	M16	⅝"	415

NOTE: For jointing other core configurations/sizes please contact Sicame Technical Dept.

The **Hepworth 'ML'** range of mechanical lugs has been designed as a practical alternative to crimping or sweating methods, thereby offering the following advantages: -

- Terminations can be jointed using simple hand tools, therefore specialised tooling or sweating skills are not required.
- The bolted connection to the busbar, or any other equipment, can be accurately located before the conductor is finally secured within the barrel of the lug, thereby avoiding any problems of elongation and axial alignment.
- The mechanical lugs have been short circuit tested, and are suitable for LV/MV applications.

ML Connectors

Physical Dimensions

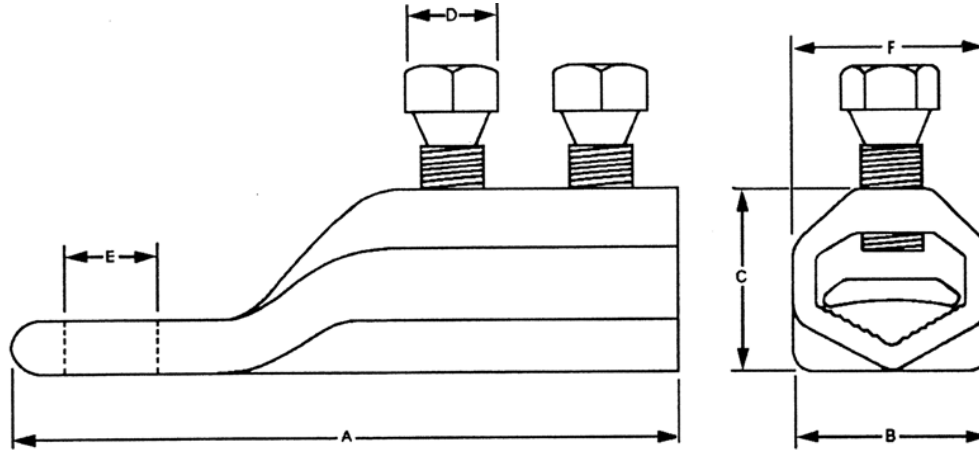

Product Reference	Dimensions (mm)					
	A	B	C	D A/F	E	F
ML1-12	95	32.0	25.0	17.0	13.0	25.0
ML1-16	95	32.0	25.0	17.0	17.0	25.0
ML2-12	125	34.0	32.5	17.0	13.0	34.0
ML2-16	125	34.0	32.5	17.0	17.0	34.0
ML3-12	145	40.0	41.0	17.0	13.0	40.0
ML3-16	145	40.0	41.0	17.0	17.0	40.0
ML3-20	145	40.0	41.0	17.0	22.0	40.0
ML4	155	47.5	51.0	17.0	17.0	47.5

Material

Aluminium Alloy

Test Specification

BS4579 including short-circuit tests Engineering Recommendation C79

Fitting Instructions

- Strip insulation from core equal to length of pressure pad +5mm.
- Thoroughly abrade exposed conductors.
- Wrap brass gauze around any copper conductors within the connector.
- Slacken screws and fit lug over core and fully insert pressure pad.
- Tighten screws consecutively one turn at a time until the heads have sheared.