

Straight mechanical
ferrule

MECHANICAL CONNECTORS

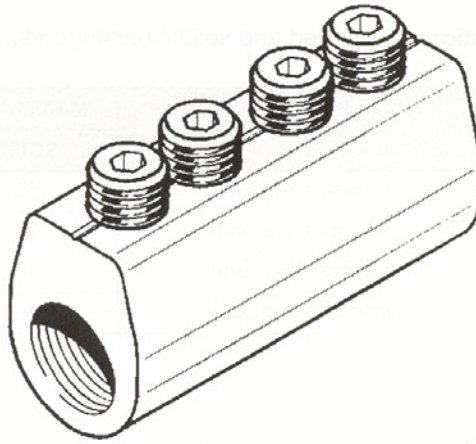

MF4 Connectors—Heat Shrink Section



Principle Application

Stranded and solid shaped service conductors.

Range

Product Reference	Type	Core c.s.a (mm ²)		Approx. Unit Weight (grammes)
		Min	Max	
MF4/5	Straight Through	6*	16	33
MF4/6	Moisture Blocked	6*	16	50
MF4/7	Straight Through	16	50	80
MF4/8	Moisture Blocked	16	50	110
MF4/15	Straight Through	16	70	92
MF4/16	Moisture Blocked	16	70	124

Note: For jointing other core configurations/sizes please contact Sicame Technical Dept
* See fitting instructions overleaf.

The **Hepworth MF4** range of mechanical connectors are designed for straight connections on stranded or solid service cables. The ferrules are manufactured in brass for suitability of jointing copper/aluminium, sector/circular shaped conductors.

This particular range of mechanical ferrules have been specifically designed for joints where a cold or heat shrink sleeving is a requirement.

Straight mechanical ferrule

MECHANICAL CONNECTORS

MF4 Connectors—Heat Shrink Section

Secondary Application

Stranded and solid circular conductors.

Range

Product Reference	Type	Maximum Core c.s.a (mm ²)	
		Solid	Stranded
MF4/5	Straight Through	35.0	35.0
MF4/6	Moisture Blocked	35.0	35.0
MF4/7	Straight Through	70.0	50.0
MF4/8	Moisture Blocked	70.0	50.0
MF4/15	Straight Through	95.0	70.0
MF4/16	Moisture Blocked	95.0	70.0

Material

Copper Alloy

Test Specifications

BS4579 : Pt 1 : 1970, BS4579 : Pt 3 : 1976

Fitting Instructions

1. Cut the service cables to length and strip the core insulation equal to half the length of connector +3mm.
2. Thoroughly abrade all conductors to be jointed.
3. Align cores within connector and tighten screws on each side of the connector consecutively, until tight.

Physical Dimensions

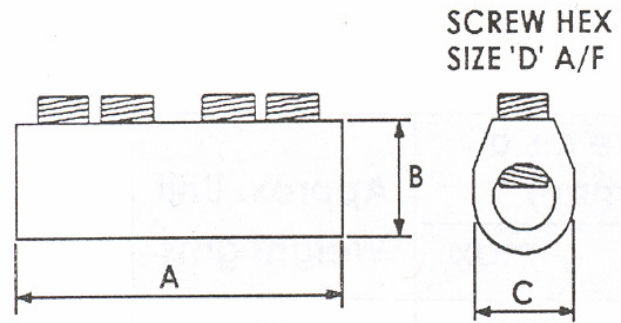

Product Reference	Dimensions (mm)			
	A	B	C	D
MF4/5	35.0	19.0	11.7	3.0
MF4/6	44.0	19.0	11.7	3.0
MF4/7	45.0	22.0	17.0	3.0
MF4/8	55.0	22.0	17.0	3.0
MF4/15	55.0	22.0	17.0	5.0
MF4/16	65.0	22.0	17.0	5.0

* Note: Conductors below 6mm² should be doubled and, if necessary, doubled again to achieve a satisfactory cross sectional area.