

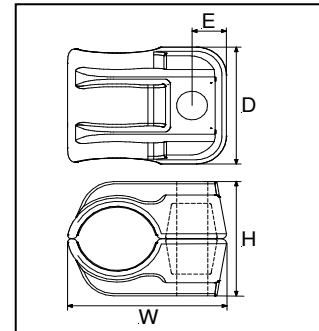

One Hole Cable Clamp Data Sheet (1F Range)

One Hole Cable Clamps are available in Black Polypropylene (B) *MDS03 Datasheet or Black Flame Retardant, Zero Halogen, Phosphorus Free Nylon (LSF) *MDS02 Datasheet.

* MDS02 and MDS03 Data Sheets are available on request.

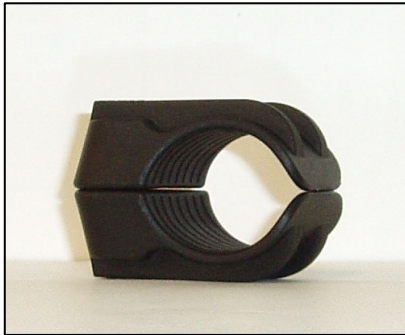

Selection Table for One Hole Cable Clamps

Part No	Material Suffix	Cable Dia. Range mm	Dimensions				Fixing Hole Clearance mm	Pack Qty.	Weight g	
			W mm	H mm	D mm	E mm			B	LSF
1F-10	B or LSF	10-13	37.8	27.0	41.4	10.2	10	100	14.6	19.6
1F-11	B or LSF	13-16	41.2	30.0	41.4	10.4	10	100	17.0	23.0
1F-12	B or LSF	16-19	44.3	33.0	41.4	10.7	10	100	19.6	26.4
1F-13	B or LSF	19-23	48.2	36.0	41.4	10.9	10	100	22.4	30.2
1F-14	B or LSF	23-27	52.2	40.0	41.4	11.3	10	100	25.8	34.6
1F-15	B or LSF	27-32	57.1	44.0	41.4	11.6	10	100	29.2	39.0
1F-16	B or LSF	32-38	63.1	49.0	41.4	12.1	10	100	34.2	46.2
1F-17	B or LSF	38-46	71.3	58.0	41.4	12.9	10	50	47.8	64.0
1F-18	B or LSF	46-51	77.3	67.0	41.4	13.5	10	50	54.0	73.2
1F-19	B or LSF	51-57	83.2	72.0	41.4	13.9	10	50	59.0	80.4

Testing Information

One Hole Cable Clamps have been tested in line with the new European Standard of "Cable Cleats for Electrical Installations" BS EN 50368:2003. Typical results below.					
Properties	BS EN 50368:2003 Classification Clause	Units / Classification B	Units / Classification LSF	Test Data B	Test Data LSF
Cleat Type	6.1, 6.1.2	Non Metallic	Non Metallic	-	-
Impact Resistance	6.2, 6.2.5, 9.3	Very Heavy Classification (>6.7kg @ 300mm)	Very Heavy Classification (>6.7kg @ 300mm)	Pass	Pass
Resistance to Electro Mechanical Force	6.3	Refer to Ellis Patents for further details.			
Temperature for Permanent Application	6.4	°C	°C	-40 to 40	-40 to 60
Needle Flame Test	6.5, 10.0	Application Time (seconds)	Application Time (seconds)	>30	>120
Lateral Load Test	9.2	Newtons (N)	Newtons (N)	320	470
Axial Movement Test	9.5	Newtons (N)	Newtons (N)	160	360



CABLE JOINTS, CABLE TERMINATIONS, CABLE GLANDS, CABLE CLEATS, FEEDER PILLARS, FUSE LINKS, ARC FLASH, CABLE ROLLERS, CUT-OUTS

11KV 33KV CABLE JOINTS & CABLE TERMINATIONS
 FURSE EARTHING
 www.cablejoints.co.uk
 Thorne and Derrick UK

Tel 0044 191 490 1547 Fax 0044 191 477 5371
 Tel 0044 117 977 4647 Fax 0044 117 9775582