



WWW.CABLEJOINTS.CO.UK
THORNE & DERRICK UK
TEL 0044 191 490 1547 FAX 0044 477 5371
TEL 0044 117 977 4647 FAX 0044 977 5582
WWW.THORNEANDDERRICK.CO.UK

Euromold

a Nexans company



Medium voltage separable
connectors and bushings
- Interface C -

Catalogue 2006



EUROMOLD

Euromold is the leading European specialised designer, manufacturer and distributor of prefabricated cable accessories for medium voltage energy distribution. Euromold provides a complete range of accessories for underground cables: pre-moulded EPDM or silicone rubber connectors, terminations and joints for cables and epoxy bushings for transformers and switch gear, as well as a large range of cold-shrinkable terminations and joints from 12 to 42 kV.

Euromold is also the manufacturer of electrical components for the high voltage accessories of the Nexans group.

ISO 9001 Certificate

Since 1992, Euromold's commitment to quality is demonstrated by its ISO 9001 certification.

International standards

All our products meet the International standards like CENELEC HD 629.1, CENELEC EN 50180, IEC 137, IEEE 386 & 404... or country specifications. Official certificates, CESI, KEMA, ATEX... prove the conformity of our products. Long duration tests of existing or new products are continuously performed in our test fields.

Laboratory accreditation

Since June 2000, Euromold's independent ELAB laboratory obtained the BELTEST accreditation no. 192-T-ISO 17025 conform with the European standards for laboratories ISO 17025 for electrical testing of medium voltage cable accessories according to the International standards IEC 61442 and HD 629.

While every care is taken to ensure that the information contained in this publication is correct, no legal responsibility can be accepted for any inaccuracy. EUROMOLD NV reserves the right to alter or modify the characteristics of its products described in this catalogue as standards and technology evolve.

SEPARABLE CONNECTORS AND BUSHINGS INTERFACE C

Table of contents

- 400LB - elbow connector
- 430TB-630A - tee connector
- 400TB - tee connector
- 440TB - tee connector
- 300PB-630A - coupling connector
- 400AR-3 - equipment bushing
- 400A-24B - in-air bushing
- 400PB-XSA - surge arrester
- 400TR & 400TR-LB - test rod
- Accessories
- Possible arrangements
- Fixings for equipment bushings
- 400TK-400SW installation tools

Interface C

Dimensions according to
European CENELEC EN
501810 and 50181 (in mm).

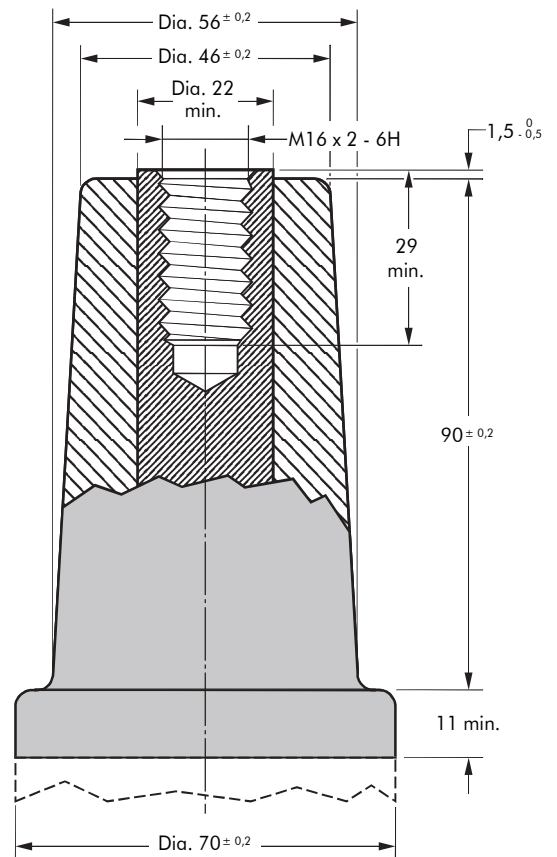

Connecting possibilities

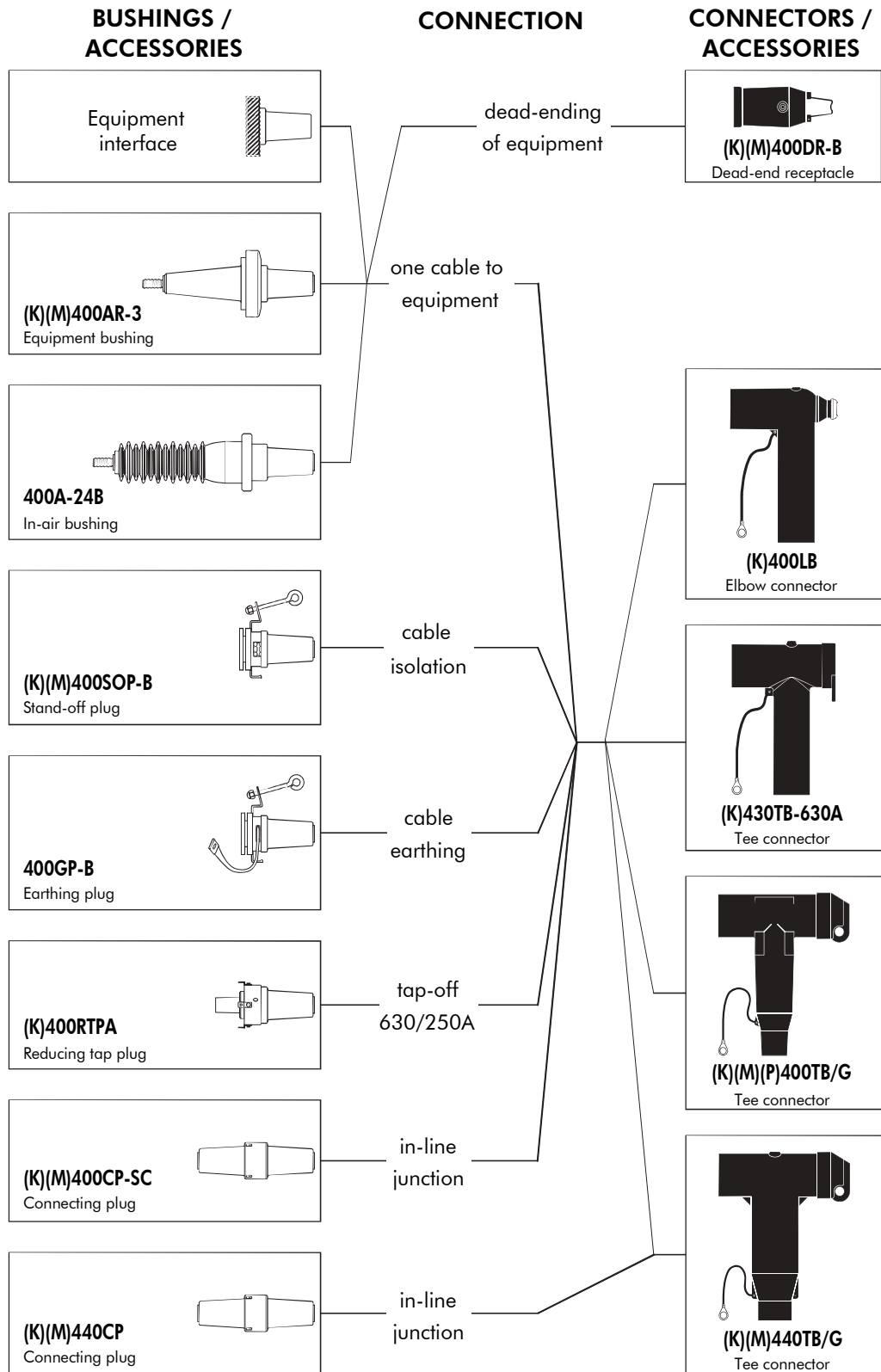

400LB INTERFACE C ELBOW CONNECTOR

Up to 24 kV - 630 A

Application

Separable elbow connector designed to connect polymeric insulated cable to equipment (transformers, switch gear, motors...).

Also connects cable to cable, using the appropriate mating part.

Technical characteristics

- The thick conductive EPDM jacket provides a total safe to touch screen which ensures safety for personnel.
- Each separable connector is tested for AC withstand and partial discharge prior to leaving the factory.

6/10 (12) kV
6.35/11 (12) kV
8.7/15 (17.5) kV
12/20 (24) kV
12.7/22 (24) kV

Design

Separable connector comprising:

1. Conductive EPDM insert.
2. Conductive EPDM jacket.
3. Insulating EPDM layer moulded between the insert and the jacket.
4. Type C - 630 A interface as described by CENELEC EN 50180 and 50181.
5. Conductor connector (not included in the standard kit).
6. Insulating plug.
7. Cable reducer.
8. Earth lead.
9. Transition contact M10/M16.

The screen break design enables cable outer sheath testing without removing or dismantling the connector.

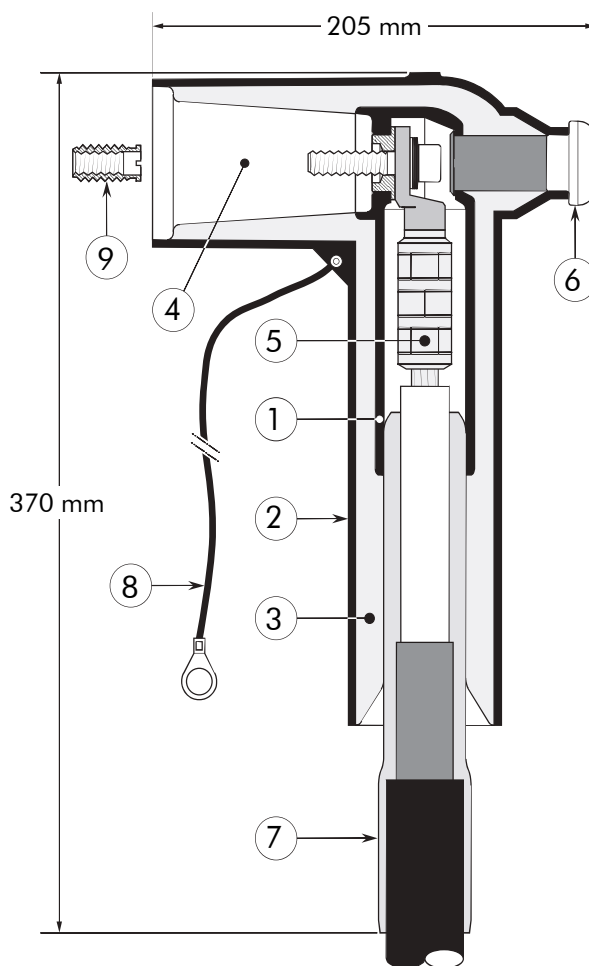

Specifications and standards

The separable connector 400LB meets the requirements of CENELEC HD 629.1.

Separable connector type	Voltage U_m (kV)	Current I_r (A)	Conductor size (mm ²)	
			min.	max.
400LB	12	630	25	300
K400LB	24	630	25	300

Kit contents

The complete (K)400LB elbow connector kit comprises 3 x the following components:

The kit also comprises lubricant, wipers, installation instructions and crimp chart.



Connector housing
(K)400BLB

Transition
contact +
screw assembly
400LTS

Compression
lug (optional)
400LBC-X

Insulating
plug
400LBP

Cable reducer
411CA-W

Ordering instructions

Select the part number which gives the best centring to the cable core insulation diameter.
Add a 'K' for use up to 24 kV.

For conductors 240 and 300 mm²:

We automatically supply the conductor compression lugs for 240 and 300 mm² aluminium conductors and 300 mm² copper conductors.

Example:

The copper wire screened cables are 24 kV, 240 mm² stranded aluminium with a diameter over core insulation of 32.2 mm.
Order 3 x K400LB-27-240(K)M-12-2 elbow connector kit.

Table W

Ordering part number	Dia. over core insulation (mm)	
	min.	max.
3 x 400LB-11	12.0	17.5
3 x 400LB-15	16.0	22.0
3 x 400LB-19	20.0	26.5
3 x 400LB-22	23.5	31.0
3 x 400LB-25(-X)	26.5	32.5
3 x 400LB-27(-X)	28.5	37.5

Table X

Conductor size (mm ²)	Aluminium conductor	Copper conductor
	DIN hexagonal	DIN hexagonal
240	240(K)M-12-2	-
300	300(K)M-12-2	300(K)M-11-2

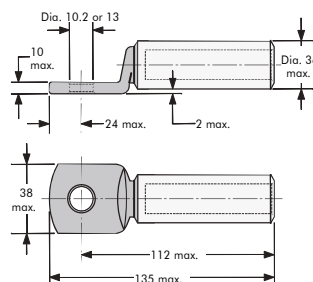

Notes for conductors from 25 up to 185 mm²:

We do not supply the compression lugs for cables from 25 up to 185 mm². All types of cable lugs can be used. The lugs must be within the dimensions specified.

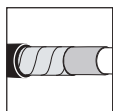

For use with copper tape screened cables.
Order: Kit MT.

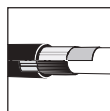

For use with Alupe or C 33-226 cables.
Please contact our representative.

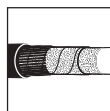

For use with fabric tape (graphite) screened cables.
Order additional semi-conductive tape (type TSC).



For use with other cable types.
Please contact our representative.



For outdoor applications.
Order: +MWS.



Components can be ordered individually.

430TB-630A INTERFACE C TEE CONNECTOR

Up to 24 kV - 630 A

Application

Separable tee shape connector (bolted type) designed to connect polymeric insulated cable to equipment (transformers, switch gear, motors, ...).

Also connects cable to cable when using the appropriate mating parts.

Technical characteristics

- A thick conductive EPDM jacket provides a total safe to touch screen.
- Each separable connector is tested for AC withstand and partial discharge prior to leaving the factory.

6/10 (12) kV
6.35/11 (12) kV
8.7/15 (17.5) kV
12/20 (24) kV
12.7/22 (24) kV

Design

1. Type C - 630 A interface as described by CENELEC EN 50180 and 50181.
2. Clamping screw.
3. Conductive EPDM insert.
4. Insulating EPDM layer moulded between the insert and the jacket.
5. Conductive EPDM jacket.
6. Conductive rubber cap.
7. Basic insulating plug (standard version without voltage detection point).
8. Conductor connector
9. Cable reducer.
10. Earthing lead.

The screen break design enables cable outer sheath testing without removing or dismantling the connector.

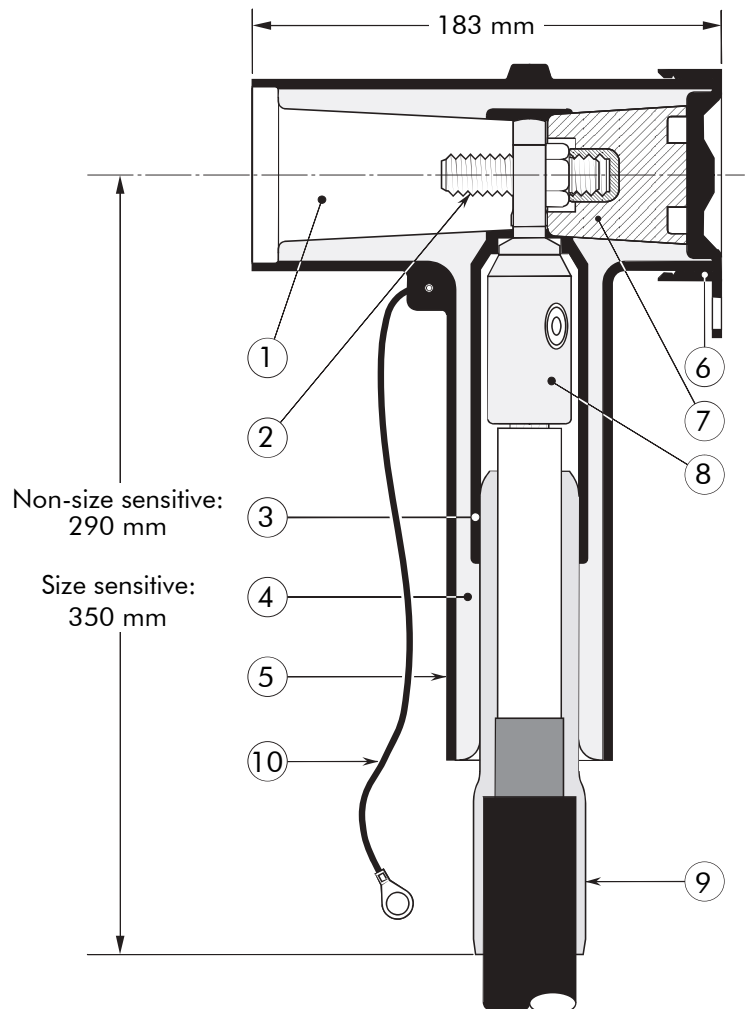

Specifications and standards

The separable connector 430TB-630A meets the requirements of CENELEC HD 629.1.

Separable connector type	Voltage U_m (kV)	Current I_r (A)	Conductor size (mm ²)	
			min.	max.
430TB-630A	12	630	35	300
K430TB-630A	24	630	35	300

Kit contents

The complete (K)430TB-630A tee connector kit comprises 3 x the following components:

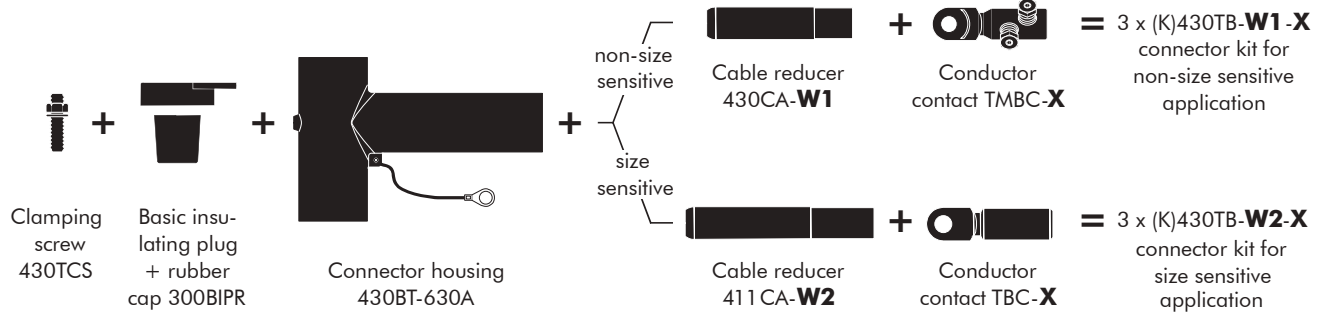

The kit also comprises lubricant, wipers, water sealing mastic, installation rod, installation instructions and crimp chart.

Ordering instructions

To order the tee connector, use the tables beside to substitute for **W1/W2** and **X** in the formulas.

- From table W1 or W2:** select the symbol which gives the best centring of your core insulation diameter.
- From table X:** according to your conductor size and type, select the designation which completes the part number.

Voltage Um (kV)	Non-size sensitive	Size sensitive
12	3 x 430TB-W1-X	3 x 430TB-W2-X
24	3 x K430TB-W1-X	3 x K430TB-W2-X

Table W1

Dia. over core insulation (mm)		W1
min.	max.	
19.0	32.6	18

Table W2

Dia. over core insulation (mm)		W2
min.	max.	
12.0	17.5	11
16.0	22.0	15
20.0	26.5	19
23.5	31.0	22
26.5	32.5	25
28.5	37.5	27

Table X

Conductor size (mm ²)	Aluminium conductor			Copper conductor	
	DIN hexagonal	Deep indent	Bolted	DIN hexagonal	Bolted
35	35(K)M-10-2	35(K)M-10-1		35(K)M-11-2	
50	50(K)M-10-2	50(K)M-10-1	-	50(K)M-11-2	-
70	70(K)M-10-2	70(K)M-10-1		70(K)M-11-2	
95	95(K)M-10-2	95(K)M-10-1		95(K)M-11-2	
120	120(K)M-10-2	120(K)M-10-1		120(K)M-11-2	
150	150(K)M-10-2	150(K)M-10-1	95.240-14-5	150(K)M-11-2	95.240-14-5
185	185(K)M-10-2	185(K)M-10-1		185(K)M-11-2	
240	240(K)M-10-2	240(K)M-10-1		240(K)M-11-2	
300	300(K)M-10-2	-	-	300(K)M-11-2	-

Example:

The cable is 24 kV, 150 mm² compact stranded copper with a diameter over core insulation of 27.5 mm. Order 3 x K430TB-18-95.240-14-5 for a non-size sensitive application or 3 x K430TB-22-150(K)M-11-2 for a size sensitive application.

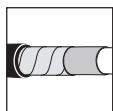

For use with copper tape screened cables. Order: Kit MT.

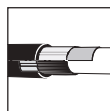

For use with Alupe or C 33-226 cables. Please contact our representative.

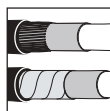

For use with easy strip semi-conductive screened cables. Order: Field control mastic (type MFC).



For use with other cable types. Please contact our representative.



For outdoor applications. Order: +MWS.

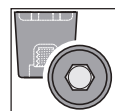

Basic insulating plug also available with a voltage detection point. Order: - /VD.

400TB INTERFACE C TEE CONNECTOR

Up to 41.5 kV - 630 A

Application

Separable tee shape connector (bolted type) designed to connect polymeric insulated cable to equipment (transformers, switch gear, motors, ...).

Also connects cable to cable when using the appropriate mating parts.

Technical characteristics

- The thick conductive EPDM jacket provides a total safe to touch screen which ensures safety for personnel.
- Each separable connector is tested for AC withstand and partial discharge prior to leaving the factory.

6/10	(12)	kV
6.35/11	(12)	kV
8.7/15	(17.5)	kV
12/20	(24)	kV
12.7/22	(24)	kV
18/30	(36)	kV
19/33	(36)	kV
20.8/36	(41.5)	kV

Design

Separable connector comprising:

1. Conductive EPDM insert.
2. Conductive EPDM jacket.
3. Insulating EPDM layer.
4. Type C - 630 A interface as described by CENELEC EN 50180 and 50181.
5. Conductor connector.
6. Basic insulating plug (with VD point).
7. Cable reducer.
8. Conductive rubber cap.
9. Clamping screw.
10. Earthing lead.

The screen break design enables cable outer sheath testing without removing or dismantling the connector.

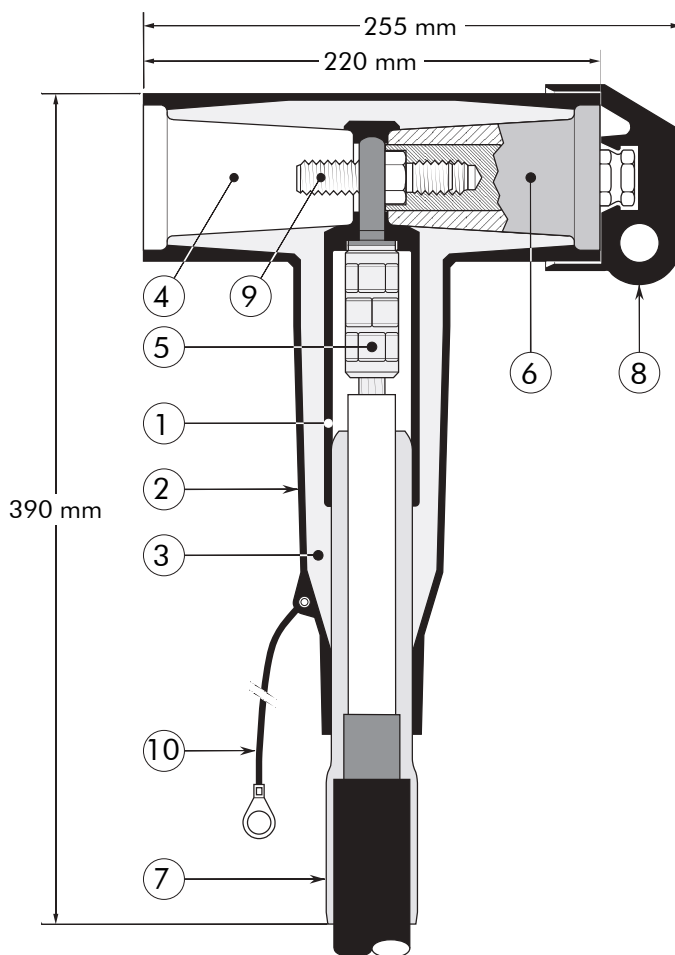

Specifications and standards

The separable connector 400TB meets the requirements of CENELEC HD 629.1 S1.

Separable connector type	Voltage U_m (kV)	Current I_r (A)	Conductor size (mm ²)	
			min.	max.
400TB/G	12	630	35	300
K400TB/G	24	630	35	300
M400TB/G	36	630	35	240
P400TB/G	41.5	630	35	240

Kit contents

The complete (K)(M)(P)400TB/G tee connector kit comprises the following components:

The kit also comprises lubricant, wipers, installation instructions and crimp chart.

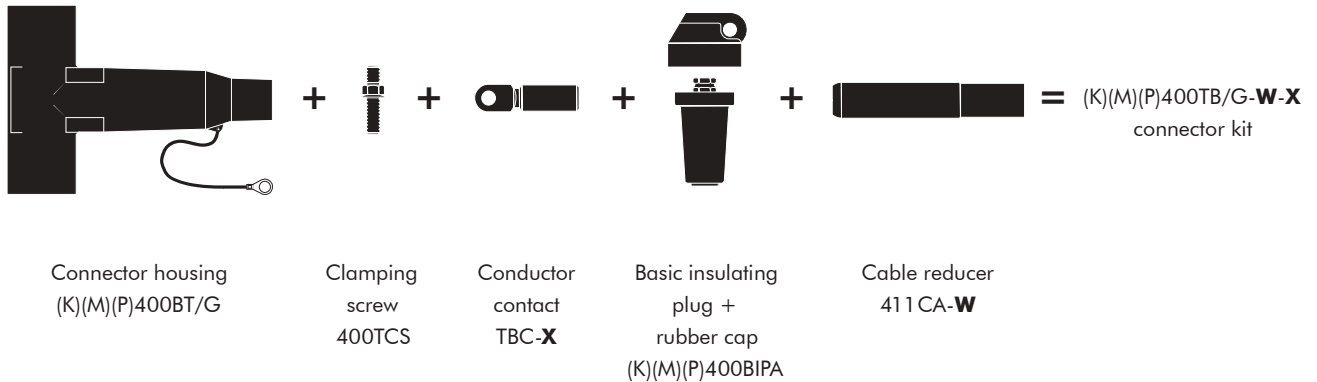

Ordering instructions

To order the tee connector, select the ordering part number which gives you the best centring of your core insulation diameter and substitute **X** using table X, according to your conductor size and type. Add a 'K' for use up to 24 kV, an 'M' for use up to 36 kV or add a 'P' for use up to 41.5 kV.

Example:

The copper wire screened cable is 36 kV, 150 mm² stranded copper with a diameter over core insulation of 32.5 mm. Order a M400TB/G-27-150(K)M-11-2 tee connector kit.

Table W

Ordering part number	Dia. over core insulation (mm)	
	min.	max.
400TB/G-11-X	12.0	17.5
400TB/G-15-X	16.0	22.0
400TB/G-19-X	20.0	26.5
400TB/G-22-X	23.5	31.0
400TB/G-25-X	26.5	32.5
400TB/G-27-X	28.5	37.5

Table X

Conductor size (mm ²)	Aluminium conductor		Copper conductor
	DIN hexagonal	Deep indent	DIN hexagonal
35	35(K)M-12-2	35KM-12-1	35(K)M-11-2
50	50(K)M-12-2	50KM-12-1	50(K)M-11-2
70	70(K)M-12-2	70KM-12-1	70(K)M-11-2
95	95(K)M-12-2	95KM-12-1	95(K)M-11-2
120	120(K)M-12-2	120KM-12-1	120(K)M-11-2
150	150(K)M-12-2	150KM-12-1	150(K)M-11-2
185	185(K)M-12-2	185KM-12-1	185(K)M-11-2
240	240(K)M-12-2	240KM-12-1	240(K)M-11-2
300	300(K)M-12-2	300KM-12-1	300(K)M-11-2

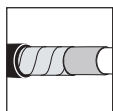

For use with copper tape screened cables.
Order: Kit MT.

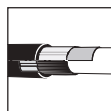

For use with AluPe or C 33-226 cables.
Please contact our representative.



For use in potentially explosive atmospheres (for 12 kV max.).
Order: -/ATEX.



For use with other cable types.
Please contact our representative.



For outdoor applications.
Order: +MWS.



Components can be ordered individually.

440TB INTERFACE C TEE CONNECTOR

Up to 36 kV - 630 A

Application

Separable tee shape connector (bolted type) designed to connect polymeric insulated cable to equipment (transformers, switch gear, motors, ...).

Also connects cable to cable when using the appropriate mating parts.

Technical characteristics

- The thick conductive EPDM jacket provides a total safe to touch screen which ensures safety for personnel.
- Each separable connector is tested for AC withstand and partial discharge prior to leaving the factory.

6/10 (12) kV
6.35/11 (12) kV
8.7/15 (17.5) kV
12/20 (24) kV
12.7/22 (24) kV
18/30 (36) kV

Design

Separable connector comprising:

1. Conductive EPDM insert.
2. Conductive EPDM jacket.
3. Insulating EPDM layer moulded between the insert and the jacket.
4. Type C - 630 A interface as described by CENELEC EN 50180 and 50181.
5. Conductor connector.
6. Basic insulating plug (with VD point).
7. Cable reducer.
8. Conductive rubber cap.
9. Clamping screw.
10. Earthing lead.

The screen break design enables cable outer sheath testing without removing or dismantling the connector.

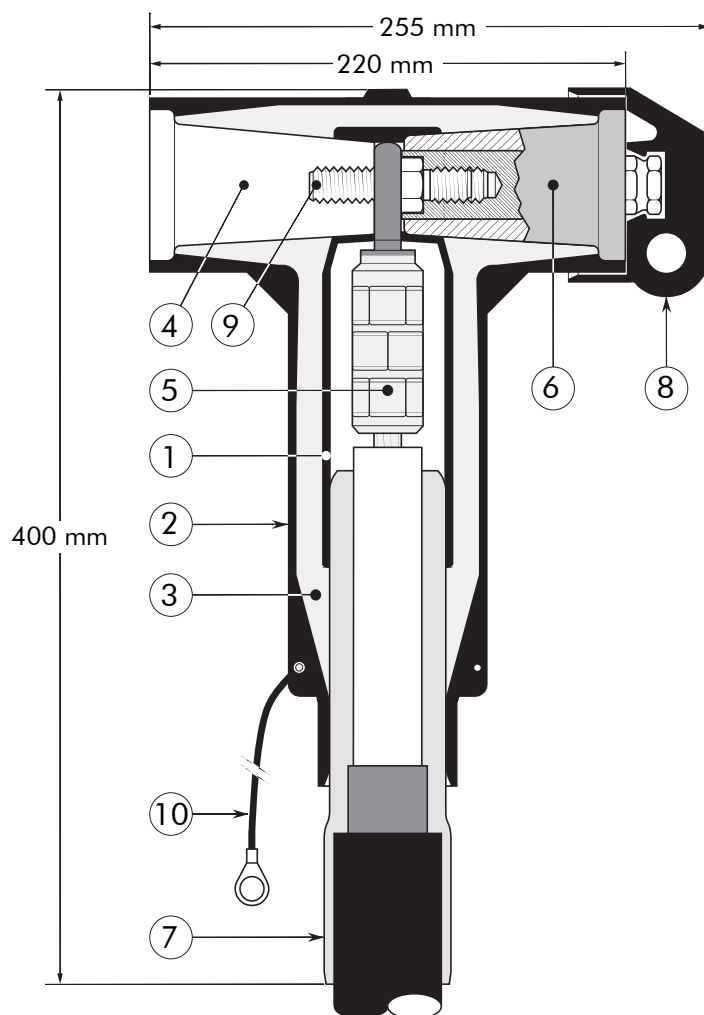

Specifications and standards

The separable connector 440TB meets the requirements of CENELEC HD 629.1.

Separable connector type	Voltage U_m (kV)	Current I_r (A)	Conductor size (mm ²)	
			min.	max.
440TB/G	12	630	185	630
K440TB/G	24	630	185	630
M400TB/G	36	630	185	630

Kit contents

The complete (K)(M)440TB/G tee connector kit comprises the following components:

The kit also comprises lubricant, wipers, installation instructions and crimp chart.

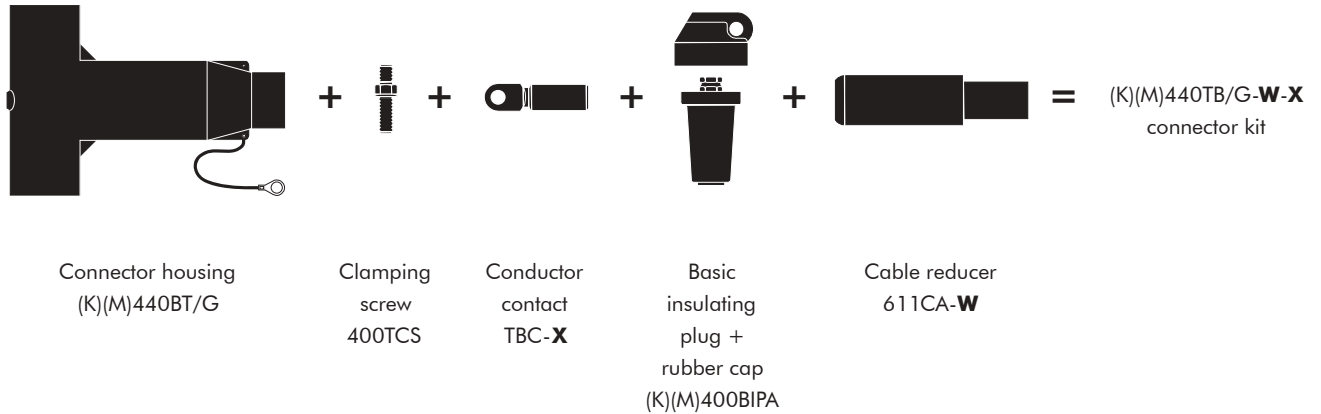

Ordering instructions

To order the tee connector, select the ordering part number which gives you the best centring of your core insulation diameter and substitute **X** using table X, according to your conductor size and type. Add a 'K' for use up to 24 kV and add an 'M' for use up to 36 kV.

Table W

Ordering part number	Dia. over core insulation (mm)	
	min.	max.
440TB/G-22- X	23.5	31.0
440TB/G-27- X	28.5	37.5
440TB/G-32- X	34.0	42.5
440TB/G-37- X	39.0	48.5
440TB/G-43- X	45.5	56.0

Table X

Conductor size (mm ²)	Aluminium conductor		Copper conductor
	DIN hexagonal	Deep indent	DIN hexagonal
185	185(K)M-12-2	185KM-12-1	185(K)M-11-2
240	240(K)M-12-2	240KM-12-1	240(K)M-11-2
300	300(K)M-12-2	300KM-12-1	300(K)M-11-2
400	400(K)M-12-2	400KM-12-1	400(K)M-11-2
500	500(K)M-12-2	500KM-12-1	500(K)M-11-2
630	–	630KM-12-1	630(K)M-11-2

Example:

The copper wire screened cable is 36 kV, 240 mm² stranded aluminium with a diameter over core insulation of 37.0 mm. Order a M440TB/G-32-240(K)M-12-2 tee connector kit.

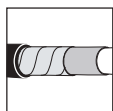

For use with copper tape screened cables.
Order: Kit MT.



For use in potentially explosive atmospheres (for 12 kV max.).
Order: -/ATEX.



For use with other cable types. Please contact our representative.



For outdoor applications.
Order: +MWS.



Components can be ordered individually.



When installed on an appropriate equipment bushing:
1250 A continuously

300PB-630A COUPLING CONNECTOR FOR 430TB-630A

Up to 24 kV - 630 A

Application

Separable coupling connector (bolted type) for dual cable arrangement. It has been designed to be used with separable Tee connector 430TB-630A.

Total maximum current is 630 A.

Technical characteristics

- A thick conductive EPDM jacket provides a total safe to touch screen.
- Each separable connector is tested for AC withstand and partial discharge prior to leaving the factory.

6/10 (12) kV
6.35/11 (12) kV
8.7/15 (17.5) kV
12/20 (24) kV
12.7/22 (24) kV

Design

1. Interface designed to fit 430TB-630A connector.
2. Bus for 300PB.
3. Conductive EPDM insert.
4. Insulating EPDM layer moulded between the insert and the jacket.
5. Conductive EPDM jacket.
6. Conductive EPDM cap.
7. Basic insulating plug.
8. Conductor connector (hexagonal crimping, deep indent crimping or bolted).
9. Cable reducer.
10. Clamping screw.
11. Earth lead.

The screen break design enables cable outer sheath testing without removing or dismantling the connector.

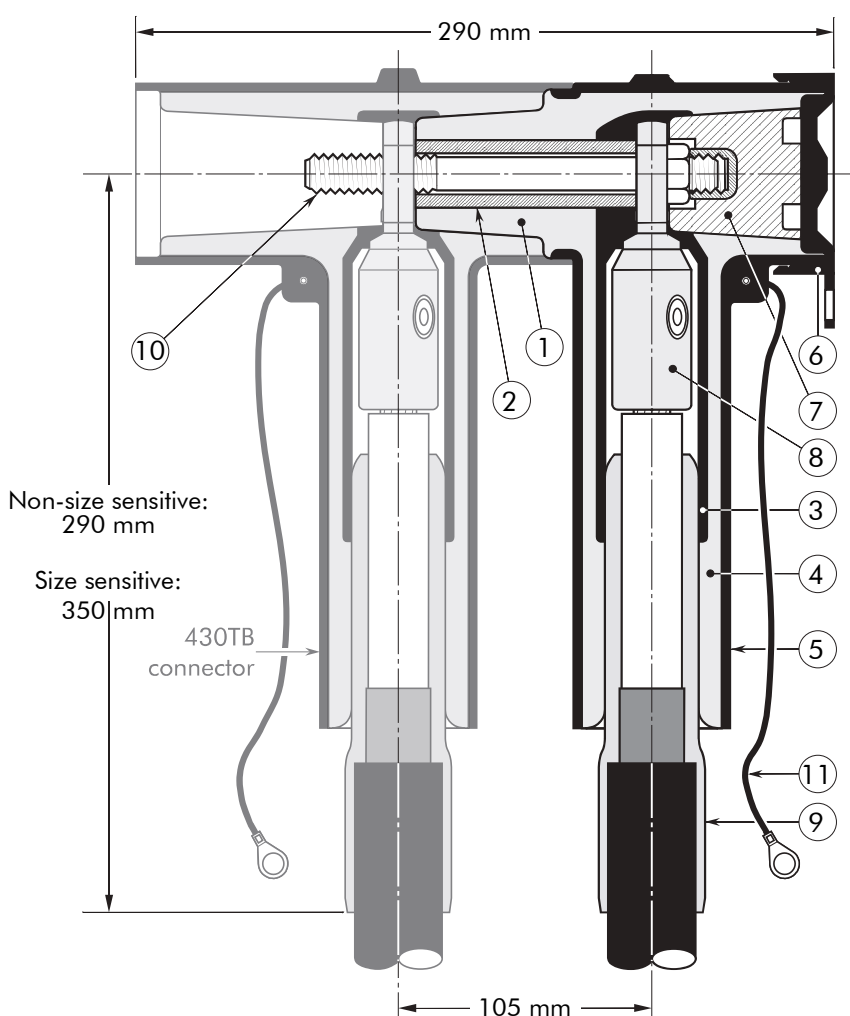

Specifications and standards

The 300PB-630A coupling connector meets the requirements of CENELEC HD 629.1 for 10 and 20 kV levels.

Separable connector type	Voltage U_m (kV)	Current I_r (A)	Conductor size (mm ²)	
			min.	max.
300PB-630A	12	630	35	300
K300PB-630A	24	630	35	300

Kit contents

The complete (K)300PB-630A coupling connector kit comprises 3 x the following components:

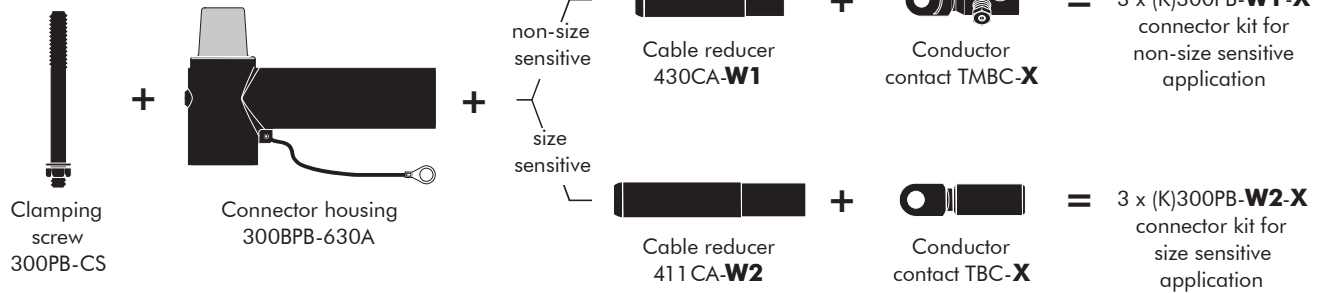

The kit also comprises silicone grease, water sealing mastic, installation rod, installation instructions and crimp chart.

Ordering instructions

To order the Tee connector, use the tables beside to substitute for **W1/W2** and **X** in the formulas.

- From table W1 or W2:** select the symbol which gives the best centring of your core insulation diameter.
- From table X:** according to your conductor size and type, select the designation which completes the part number.

Example:

The cable is 24 kV, 150 mm² compact stranded copper with a diameter over core insulation of 27.5 mm.
Order 3 x K300PB-18-95.240-14-5 for a non-size sensitive application or 3 x K300PB-22-150(K)M-11-2 for a size sensitive application.

Voltage Um (kV)	Non-size sensitive	Size sensitive
12	3 x 300PB-W1-X	3 x 300PB-W2-X
24	3 x K300PB-W1-X	3 x K300PB-W2-X

Table W1

Dia. over core insulation (mm)		W1
min.	max.	
19.0	32.6	18

Table W2

Dia. over core insulation (mm)		W2
min.	max.	
12.0	17.5	11
16.0	22.0	15
20.0	26.5	19
23.5	31.0	22
26.5	32.5	25
28.5	37.5	27

Table X

Conductor size (mm ²)	Aluminium conductor			Copper conductor	
	DIN hexagonal	Deep indent	Bolted	DIN hexagonal	Bolted
35	35(K)M-10-2	35(K)M-10-1		35(K)M-11-2	
50	50(K)M-10-2	50(K)M-10-1	-	50(K)M-11-2	-
70	70(K)M-10-2	70(K)M-10-1		70(K)M-11-2	
95	95(K)M-10-2	95(K)M-10-1		95(K)M-11-2	
120	120(K)M-10-2	120(K)M-10-1		120(K)M-11-2	
150	150(K)M-10-2	150(K)M-10-1	95.240-14-5	150(K)M-11-2	95.240-14-5
185	185(K)M-10-2	185(K)M-10-1		185(K)M-11-2	
240	240(K)M-10-2	240(K)M-10-1		240(K)M-11-2	
300	300(K)M-10-2	-	-	300(K)M-11-2	-

For use with copper tape screened cables. Order: Kit MT.	For use with fabric tape (graphite) screened cables. Order additional semi-conductive tape (type TSC).	For use with easy strip semi-conductive screened cables. Order: Field control mastic (type MFC).	For use with copper wire screened cables. No earthing device is necessary.	For use with other cable types. Please contact our representative.	For outdoor applications. Order: +MWS.

400AR-3 INTERFACE C EQUIPMENT BUSHING

Up to 36 kV - 630 A

Application

For use in equipment insulated with oil fluid, typically for transformers, switch gear, capacitors...

Technical characteristics

Each bushing is tested for AC withstand and partial discharge prior to leaving the factory.

6/10 (12) kV
6.35/11 (12) kV
8.7/15 (17.5) kV
12/20 (24) kV
12.7/22 (24) kV
18/30 (36) kV

Design

The equipment bushing is a moulded epoxy insulated part in accordance with CENELEC EN 50180.

Specifications and standards

The bolted type equipment bushings 400AR-3 meet the requirements of CENELEC EN 50180 and IEC 137.

Ordering instructions

To order the equipment bushing, specify the type. The bushing are supplied with an earth lead (/J) or an earth plate (/GS). This earth connection must be specified when ordering. E.g. M400AR-3/GS. For use in potentially explosive atmospheres (for 12 kV max.). Order: -/ATEX.

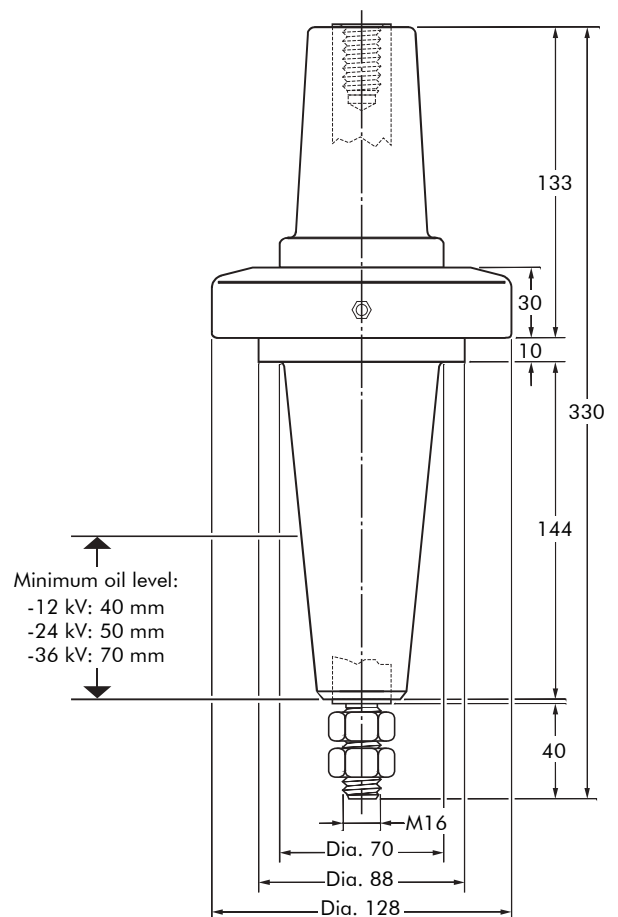

In mm.

Equipment bushing type	Voltage U_r (kV)	Current I_r (A)
400AR-3	12	630
K400AR-3	24	630
M400AR-3	36	630

400A-24B INTERFACE C IN-AIR BUSHING

Up to 24 kV - 630 A

Application

For use in equipment insulated with air, typically for transformers, switch gear, capacitors...

Technical characteristics

Each bushing is tested for AC withstand and partial discharge prior to leaving the factory.

6/10 (12) kV
6.35/11 (12) kV
8.7/15 (17.5) kV
12/20 (24) kV
12.7/22 (24) kV

Design

The equipment bushing is a moulded epoxy insulated part in accordance with CENELEC EN 50181.

Specifications and standards

The bolted type equipment bushings 400A-24B meet the requirements of CENELEC EN 50180 and IEC 137.

Ordering instructions

To order the equipment bushing, specify the type.

The bushing are supplied with an earth lead.

To include the ring clamp, add:

- /B, if per British standards.
- /D, if per German standards.
- /F, if per French standards.

E.g. 400A-24B/D.

For use in potentially explosive atmospheres (for 12 kV max.).

Order: -/ATEX.

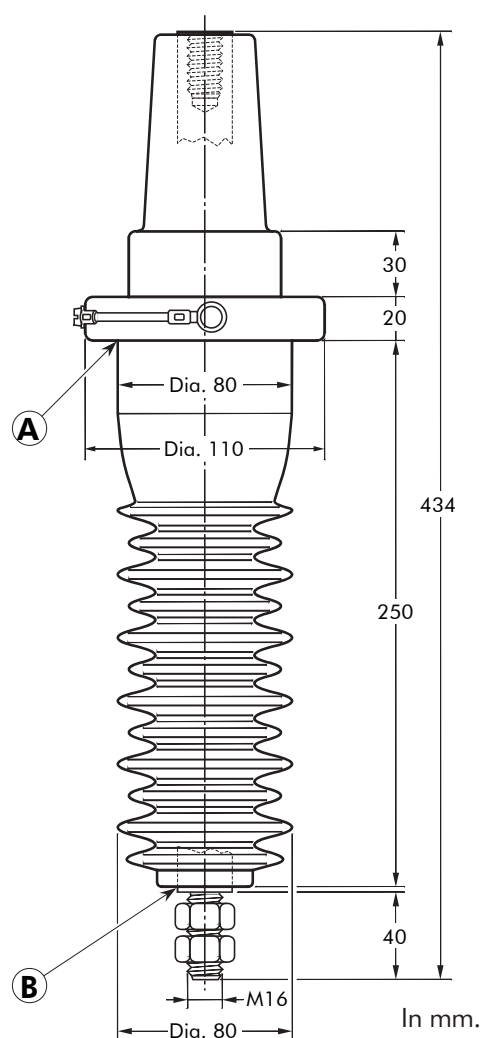

Equipment bushing type	Voltage U_r (kV)	Current I_r (A)	Creepage distance A-B (mm)
400A-24B	12	630	500
400A-24B	24	630	500

FIXINGS FOR EQUIPMENT BUSHINGS INTERFACE C

400AR-3/J bushing
DIN 42 538
German standards.

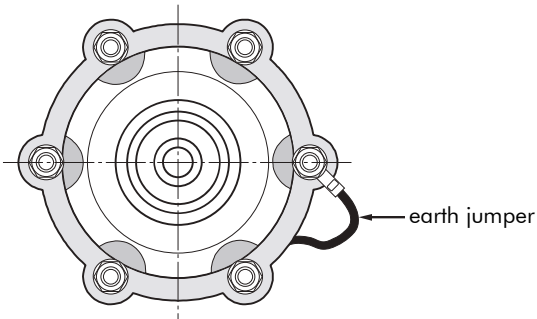
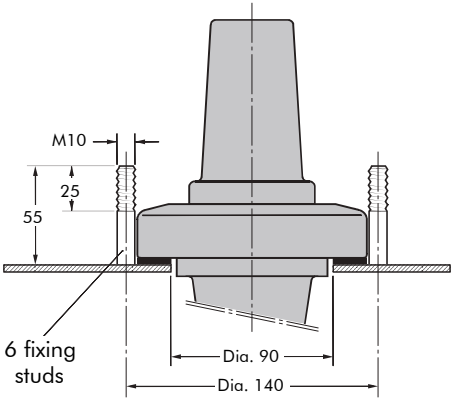
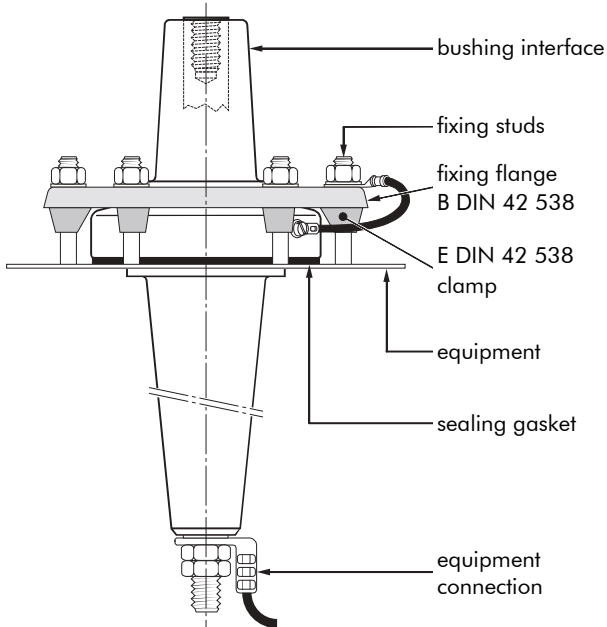

400A-24B In-air bushing

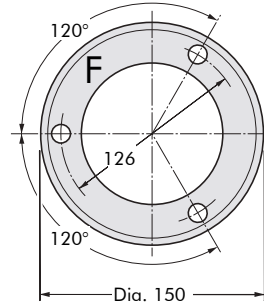
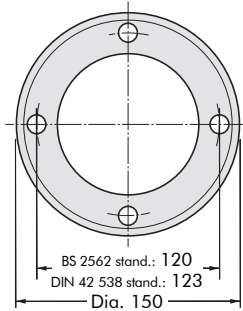
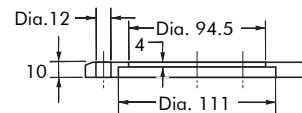
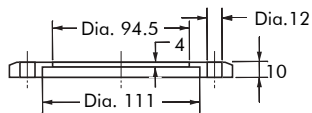
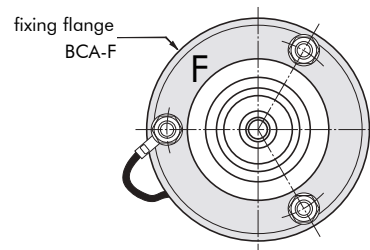
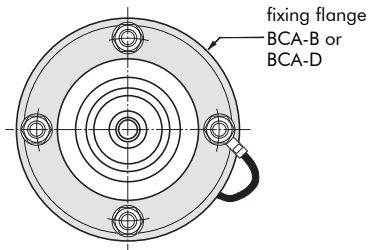
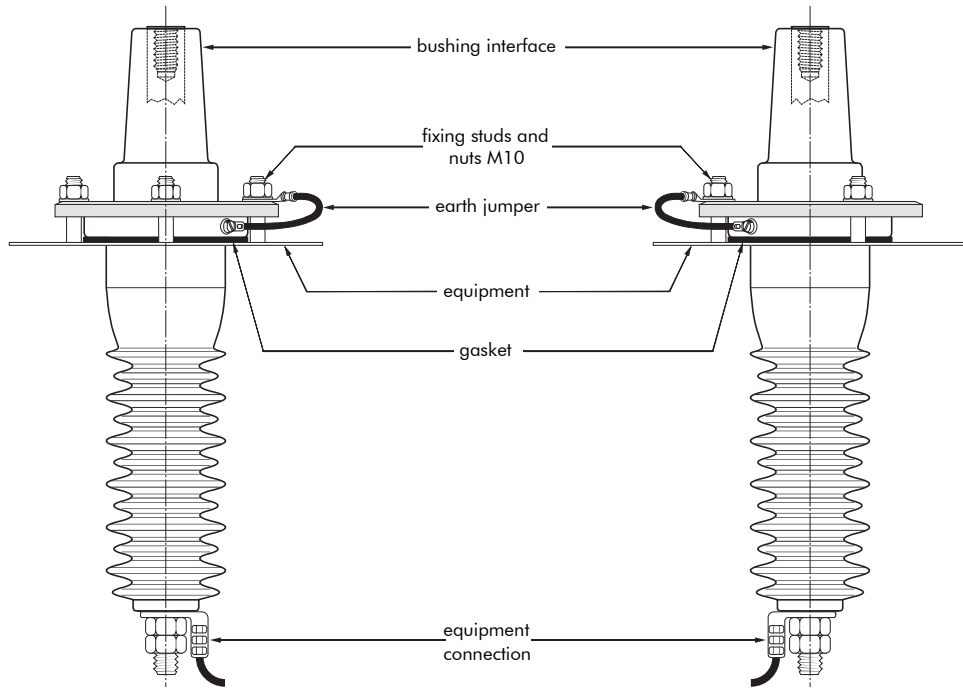

Type BCA-B : BS 2562 British standards
Type BCA-D : DIN 42 538 German standards

Type BCA-F : NFC 52-053 French standards

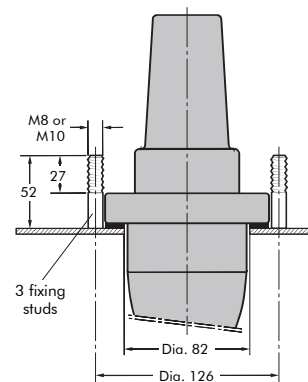
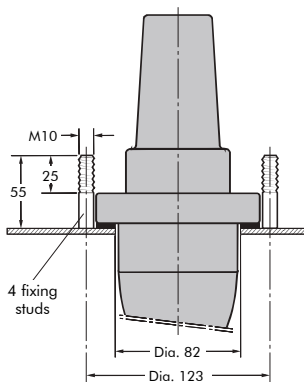

400PB-XSA INTERFACE C SURGE ARRESTER

Up to 36 kV

Application

Surge arrester designed to protect 12 and 24 kV class components, including transformers, equipment, cable and accessories from high voltage surges resulting from lightning or switching.

Technical characteristics

- This surge arrester is a metal oxide varistor surge arrester in an elbow configuration.
- Each arrester is tested for AC withstand and partial discharge prior to leaving the factory.

6/10 (12) kV
6.35/11 (12) kV
8.7/15 (17.5) kV
12/20 (24) kV
12.7/22 (24) kV
18/30 (36) kV

Design

Surge arrester comprising:

1. Conductive EPDM insert.
2. Conductive EPDM jacket.
3. Insulating EPDM layer moulded between the insert and the jacket.
4. Contact rod.
5. Earth lead.
6. Earth connection.
7. Steel cap.
8. Metal oxide valve elements.
9. Type C - 630 A interface as described by CENELEC EN 50180 and 50181.

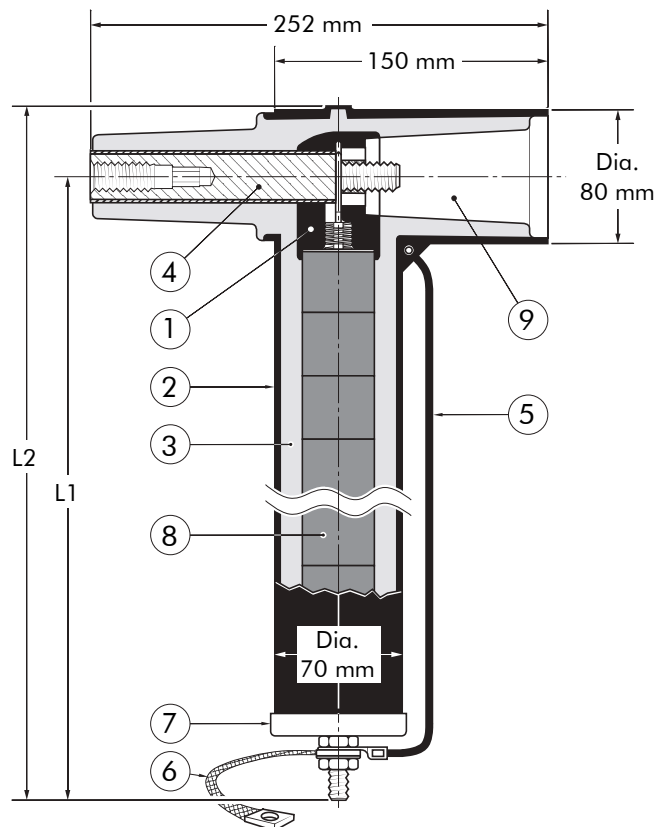

Surge arrester type	Nominal discharge current In (kA)	Rated voltage Ur (kV)	Max. continuous operating voltage Uc (kV)	Steep current residual voltage @ 5 kA [1/20 μs] (kV)	Lightning current residual voltage @ 5 kA [8/20 μs] (kV)	High current impulse withstand (kA)	Dimensions (mm)	
							L1	L2
400PB-5SA-15L	5	15	12.0	42.4	40.0	65	250	290
400PB-5SA-18L	5	18	14.4	52.7	48.0	65	250	290
400PB-5SA-22L	5	22	17.6	65.7	59.0	65	350	390
400PB-5SA-24L	5	24	19.2	70.0	64.0	65	350	390
400PB-5SA-30L	5	30	24.0	87.3	80.0	65	350	390
400PB-1 OSA-15N	10	15	12.0	46.2	40.2	100	250	290
400PB-1 OSA-18N	10	18	14.0	56.0	48.6	100	250	290
400PB-1 OSA-22N	10	22	17.6	68.9	59.8	100	350	390
400PB-1 OSA-24N	10	24	19.2	74.4	64.5	100	350	390
400PB-1 OSA-30N	10	30	24.0	92.7	80.4	100	350	390
400PB-1 OSA-36N	10	36	28.8	111.1	96.4	100	350	390
400PB-1 OSA-45N	10	45	36.0	138.2	120.0	100	450	490

Typical application and dimensions

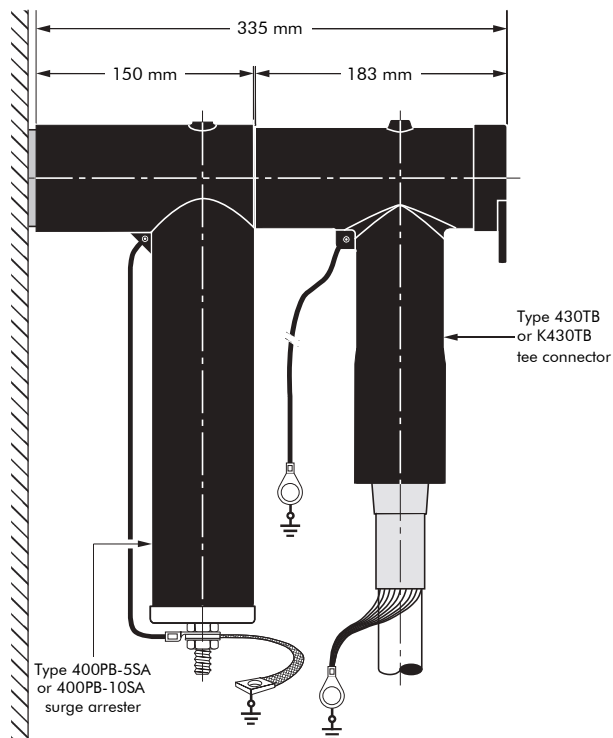
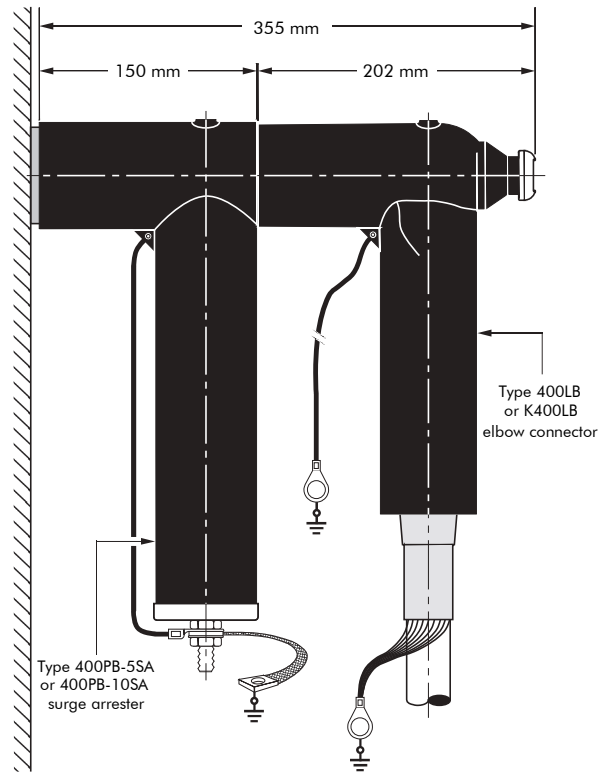
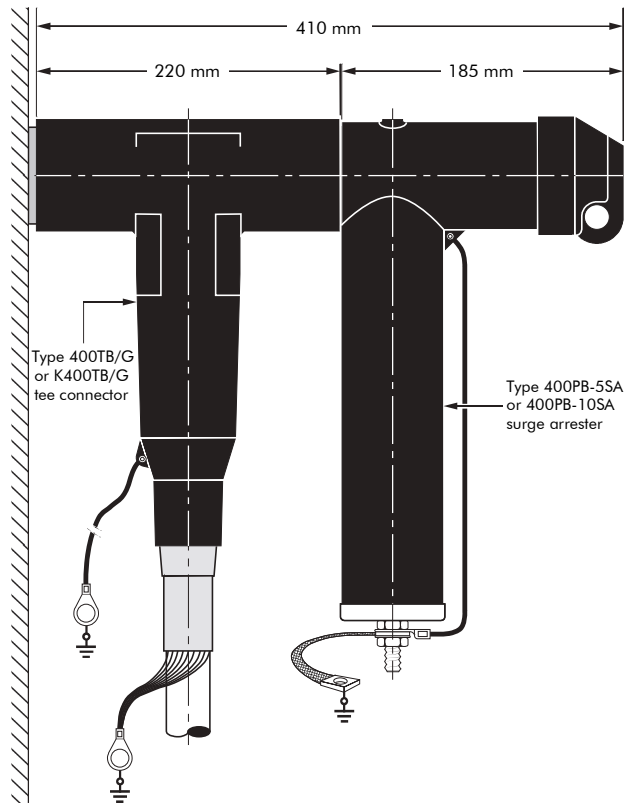

Ordering instructions

To order the surge arrester, specify the surge arrester type, as described on previous page.

Example:

For a maximum continuous operating voltage (rms) of 24 kV and a nominal discharge current of 10 kA.

Order a 400PB-10SA-24N surge arrester.

400TR and 400TR-LB INTERFACE C TEST RODS

Application

- The test rod can be used for:
 - cable fault location
 - cable testing
 - phasing checks, etc.
- Connections may be made with a cable lug, a 4 mm plug or spring clips.

Technical characteristics

- The 400TR test rod can be used with 400TE, 430TB, 400TB and 440TB connectors.
- The 400TR-LB is for use with the 400LB connector.

Design

1. Insulating shroud.
2. Threaded rod for test connection.
3. Two nuts M12.
4. Insulation.
5. Copper test rod stem.
6. Wing nut.

An insulating shroud is provided to allow the application of test voltages when bushings are closely spaced.

Installation

The test rod is mounted on to the clamping screw in the type C interface tee and coupling connectors. The test cable is connected to the threaded stem and the insulating shroud moved to its final position over the end of the test rod.

Ordering instructions

Simply specify:
400TR or 400TR-LB test rod.

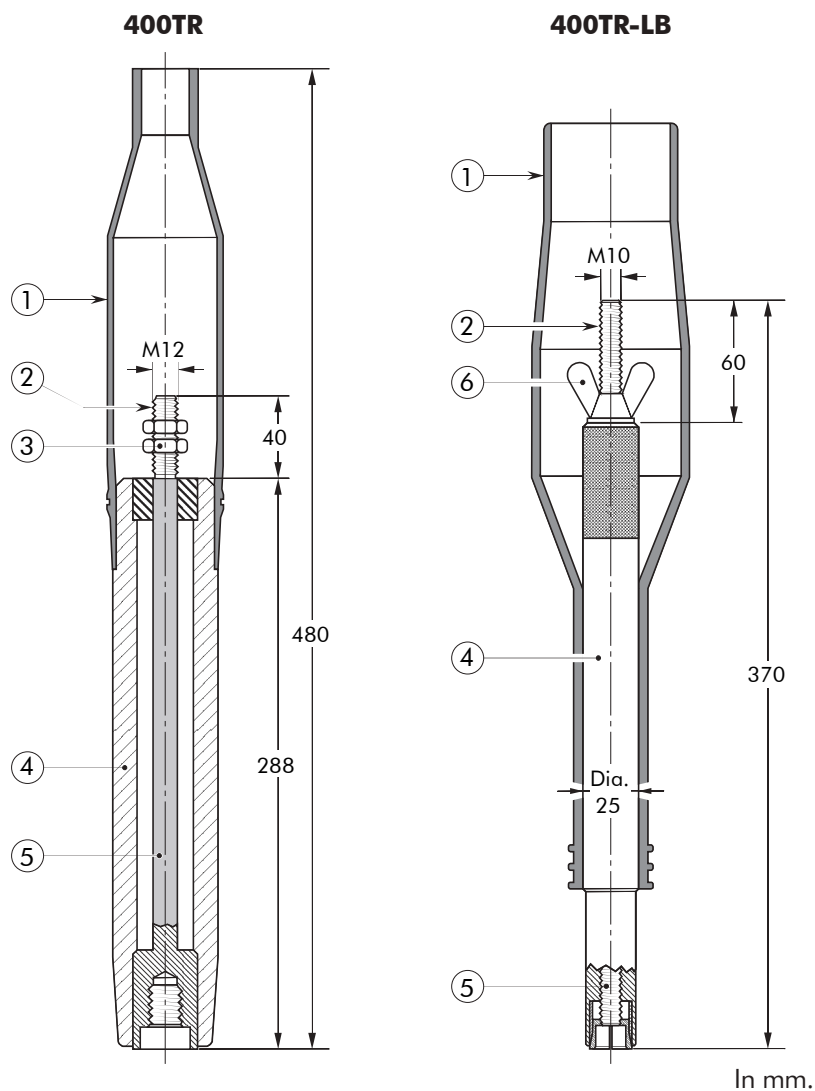

In mm.

Test rod type	Maximum A.C. test voltage (50 Hz - 1 min.)	Maximum D.C. test voltage (8 x U ₀ - 30 min.)	Impulse voltage (1.2 x 50 μs) min.
400TR	36 kV	96 kV	95 kV
400TR-LB	36 kV	96 kV	95 kV

400TK & 400SW INSTALLATION TOOL

I Application

- The box spanner and box spanner key are designed to facilitate assembly of 400TE, 400TB and 440TB connectors.
- The 400TK box spanner is used to install the 400TEF clamping pin contact or 400TCS clamping screw.
- The 400SW box spanner key fits on the hex nut of the 400BIPA basic insulating plug.

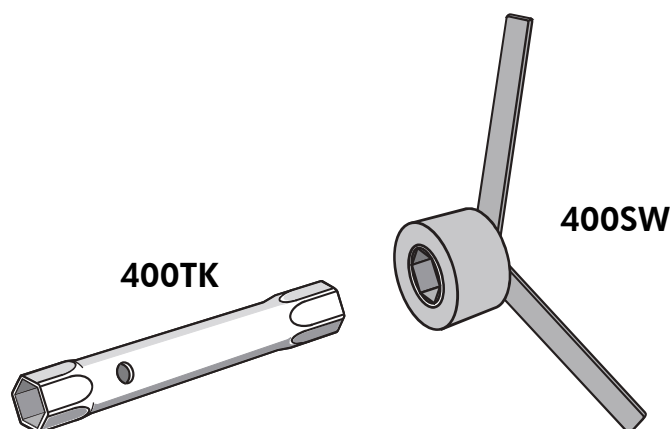

I Ordering instructions

Simply specify:

- 400TK box spanner
- 400SW box spanner key

ACCESSORIES INTERFACE C

Application

For use with connectors and bushings with an interface C as described by CENELEC EN 50180 and 50181.

Technical characteristics

All these products, except the earthing plugs, are tested for AC withstand and partial discharge prior to leaving the factory.

Up to 36 kV

6/10 (12) kV
6.35/11 (12) kV
8.7/15 (17.5) kV
12/20 (24) kV
12.7/22 (24) kV
18/30 (36) kV

400DR-B Dead-end receptacle

Fits over a bushing with a type C interface to provide 'dead-end' facility.

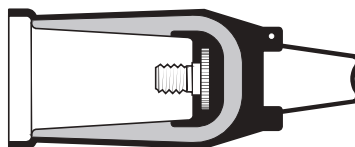

Ordering instructions

Order
400DR-B for 12 kV,
K400DR-B for 24 kV or
M400DR-B for 36 kV
applications.
The dead-end receptacle can
be supplied with an earth lead.
Order: -/G.
E.g. K400DR-B/G.

400SOP-B Stand-off plug

Is designed to support and 'dead-end' connectors with a type C interface when removed from equipment.

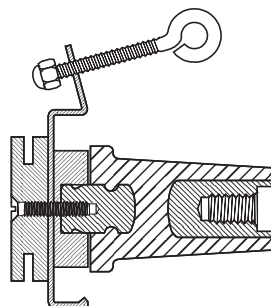

Ordering instructions

Order
400SOP-B for 12 kV,
K400SOP-B for 24 kV or
M400SOP-B for 36 kV
applications.

400GP-B Earthing plug

Is designed to support and earth connectors with a type C interface when removed from equipment.

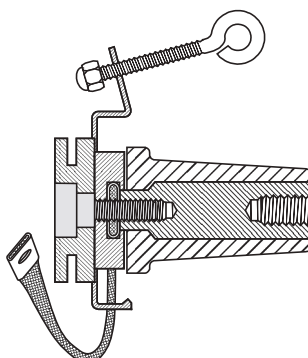

Ordering instructions

Order
400GP-B for 12, 24 or 36 kV
applications.

300GP-B Earthing plug

Is designed to earth the 430TB-630A connectors when it is fixed-mounted to the equipment (maintenance earthing).

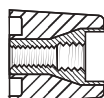

Ordering instructions

Order
300GP-B for 12 or 24 kV
applications.

400BIPA Basic insulating plug

Acts as a tightening nut for the 400TB and 440TB tee connector kits.
The plug contains a voltage detection point.
The conductive rubber protection cap is included.

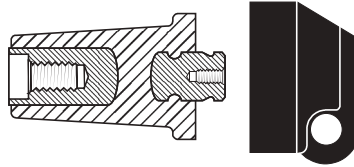

Ordering instructions

Order
400BIPA for 12 kV,
K400BIPA for 24 kV or
M400BIPA for 36 kV
applications.

400CP-SC Connecting plug

For connecting two or more connectors with a type C interface together, thus creating a separable cable joint or a multiple cable connection to equipment.

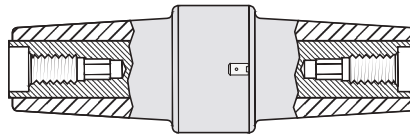

Ordering instructions

Order
400CP-SC for 12 kV,
K400CP-SC for 24 kV or
M400CP-SC for 36 kV
applications.

440CP Connecting plug

For connecting two or more 440TB connectors, thus creating a separable cable joint or a multiple cable connection to equipment.
For use up to 1250 A.
Only for use with 440TB.

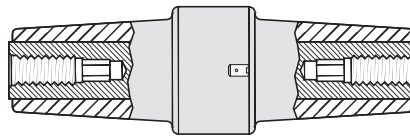

Ordering instructions

Order
440CP for 12 kV,
K440CP for 24 kV or
M440CP for 36 kV
applications.
Order: -/ATEX for use in
potentially explosive
atmospheres (for 12 kV max.).

400RTPA Reducing tap plug

Provides a type A interface to connectors with a type C interface.
A 'C' spanner, 600SW, is used to tighten the reducing tap plug on to its mating part.

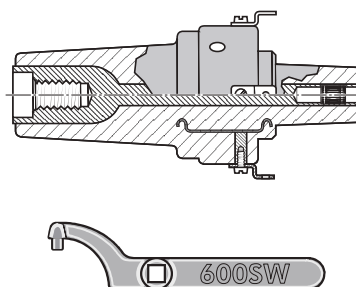

Ordering instructions

Order
400RTPA for 12 kV or
K400RTPA for 24 applications.
Order 600SW for the 'C'
spanner.

Kit MT Earthing kit for copper tape screened cables

Contains a tinned copper braid (25 mm² - L = 500 mm), a tinned copper wire for cleating and some water sealing mastic.

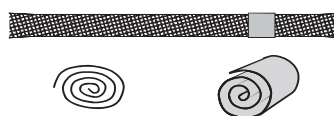

Ordering instructions

Order
Kit MT for 12 kV, 24 kV
36 kV or 41.5 kV applications.

POSSIBLE ARRANGEMENTS INTERFACE C

430TB

Single cable arrangement.
Order 430TB for 12 kV or
K430TB for 24 kV applications.

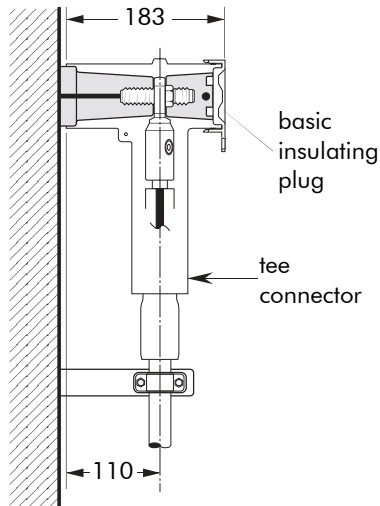

430TB+300PB

Dual cable arrangement.
Order 430TB+300PB for 12 kV
or K430TB+K300PB for 24 kV
applications.

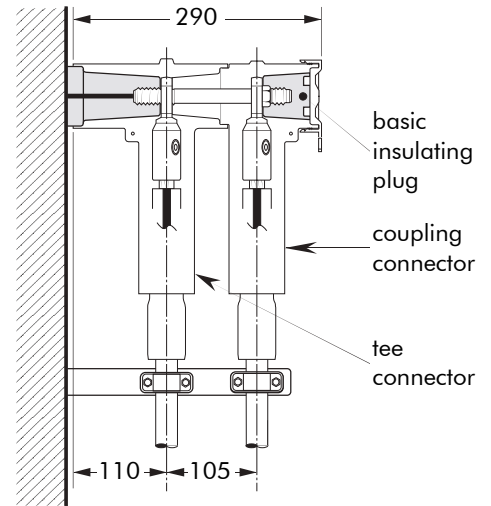

400TB/G

Single cable arrangement.
Order 400TB/G for 12 kV,
K400TB/G for 24 kV,
M400TB/G for 36 kV or
P400TB/G for 41.5 kV
applications.

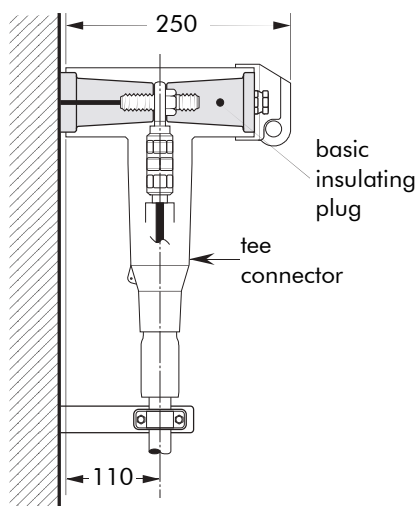

400TB/G-P2

Dual cable arrangement.
Order 400TB/G-P2 for 12 kV,
K400TB/G-P2 for 24 kV or
M400TB/G-P2 for 36 kV
applications.

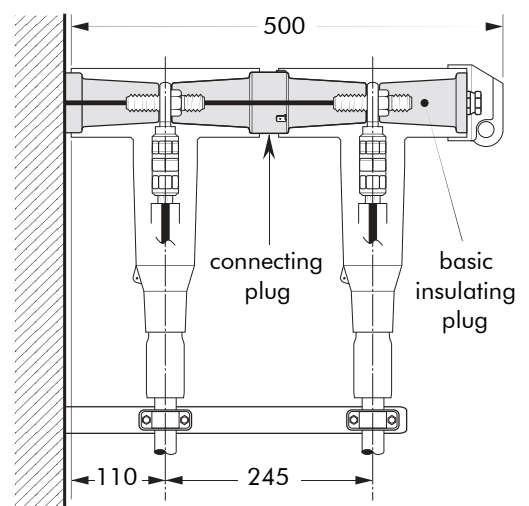

In mm.

400TB/G-L2

2-way connection.
Order 400TB/G-L2 for 12 kV,
K400TB/G-L2 for 24 kV or
M400TB/G-L2 for 36 kV
applications.

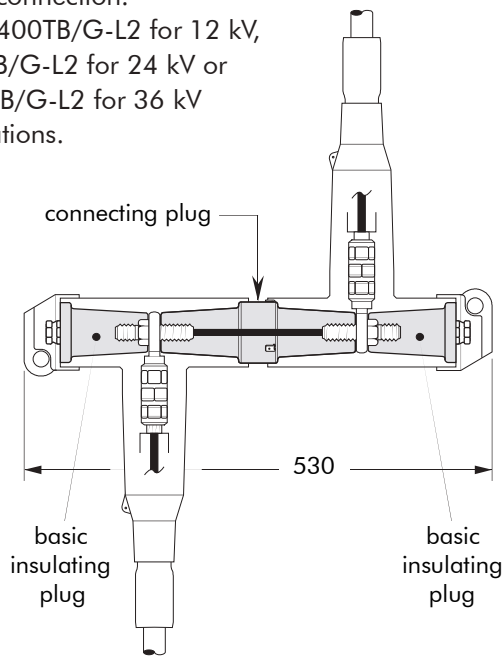

400TB/G-L5

2-way connection with tap-off.
Order 400TB/G-L5 for 12 kV
or K400TB/G-L5 for 24 kV
applications.

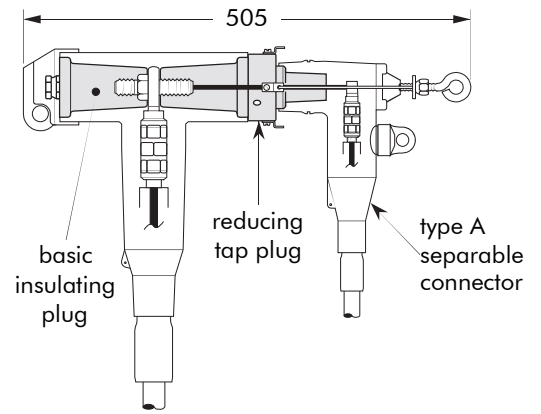

400TB/G-L3

3-way connection.
Order 400TB/G-L3 for 12 kV,
K400TB/G-L3 for 24 kV or
M400TB/G-L3 for 36 kV
applications.

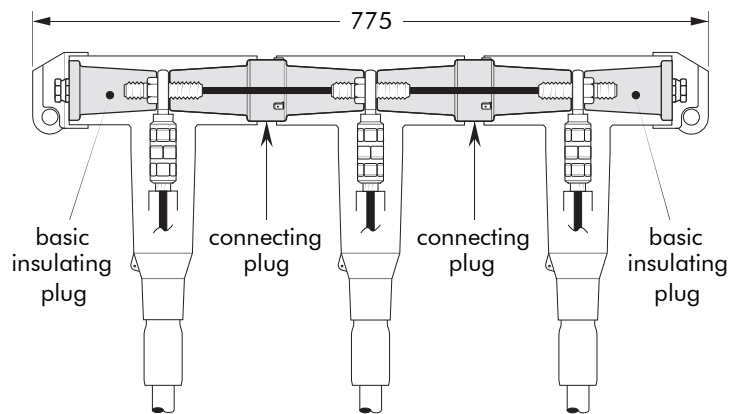

400TB/G-L4

Disconnectable tap-off.
Order 400TB/G-L4 for 12 kV,
K400TB/G-L4 for 24 kV or
M400TB/G-L4 for 36 kV
applications.

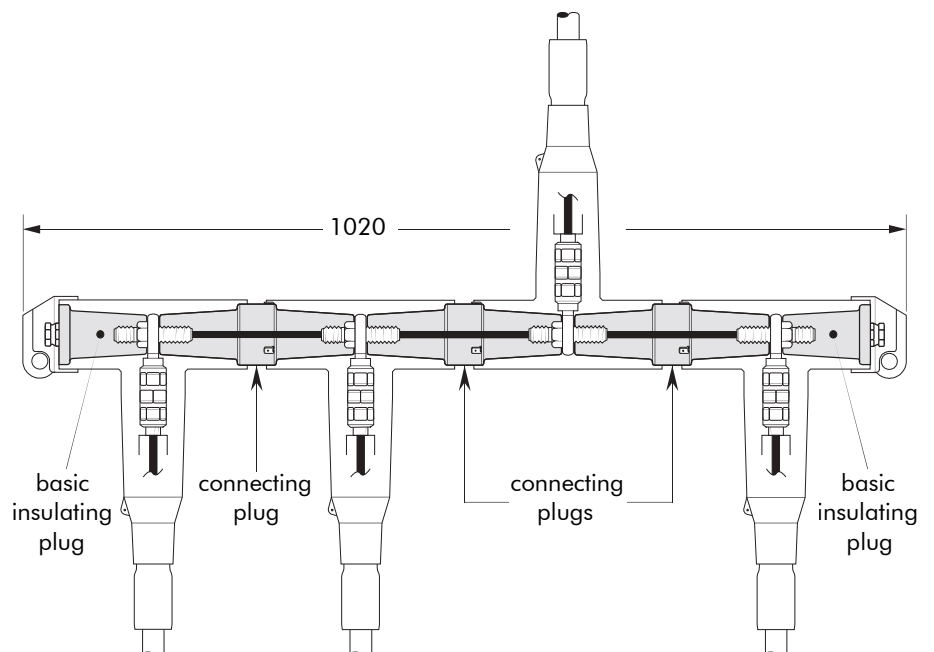

Connector on stand-off plug

Order 400SOP-B for 12 kV,
K400SOP-B for 24 kV or
M400SOP-B for 36 kV
applications.

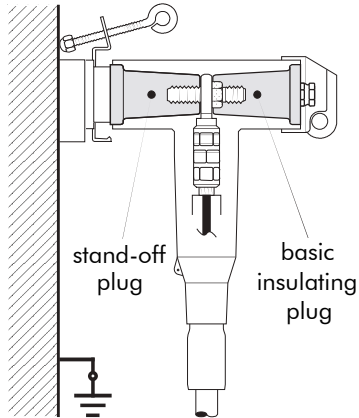

Earthing plug on connector

Order 300GP-B for 12 kV and
24 kV applications.

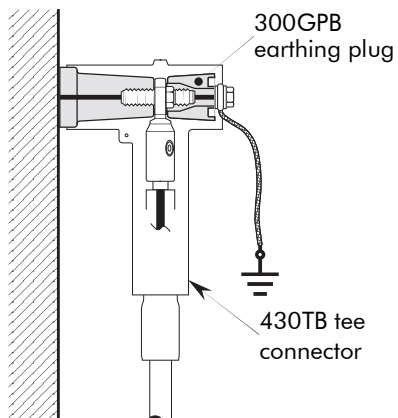

Connector on earthing plug

Order 400GP-B for 12 kV,
24 kV and 36 kV applications.

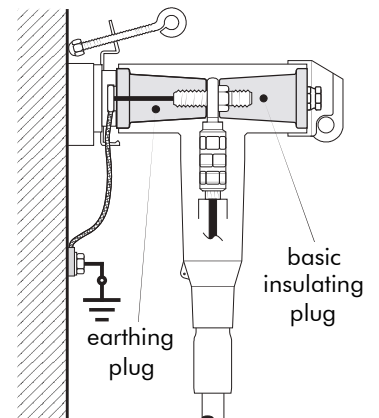

I Cable and equipment testing.

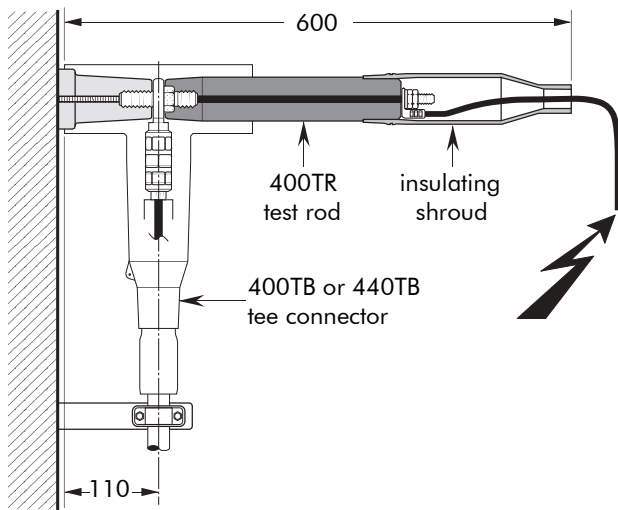
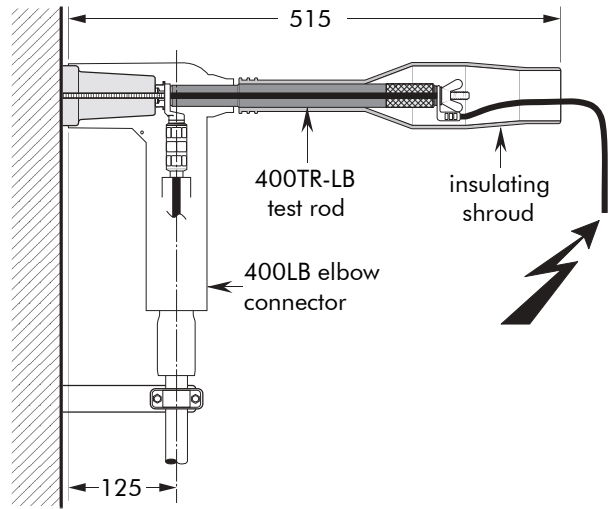
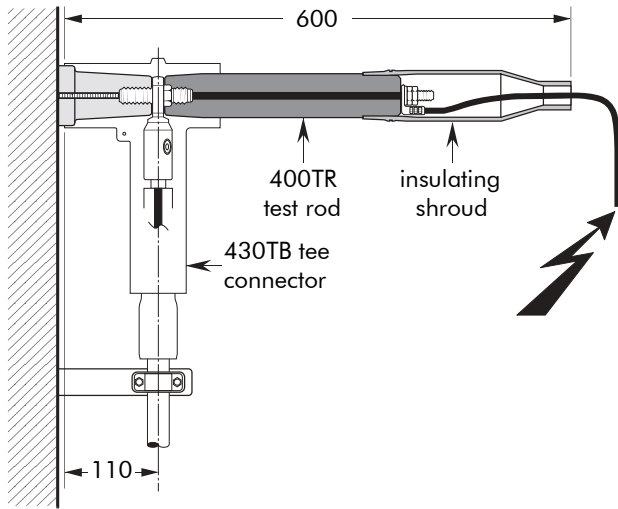



WWW.CABLEJOINTS.CO.UK
THORNE & DERRICK UK
TEL 0044 191 490 1547 FAX 0044 477 5371
TEL 0044 117 977 4647 FAX 0044 977 5582
WWW.THORNEANDDERRICK.CO.UK

Euromold
a Nexans company