

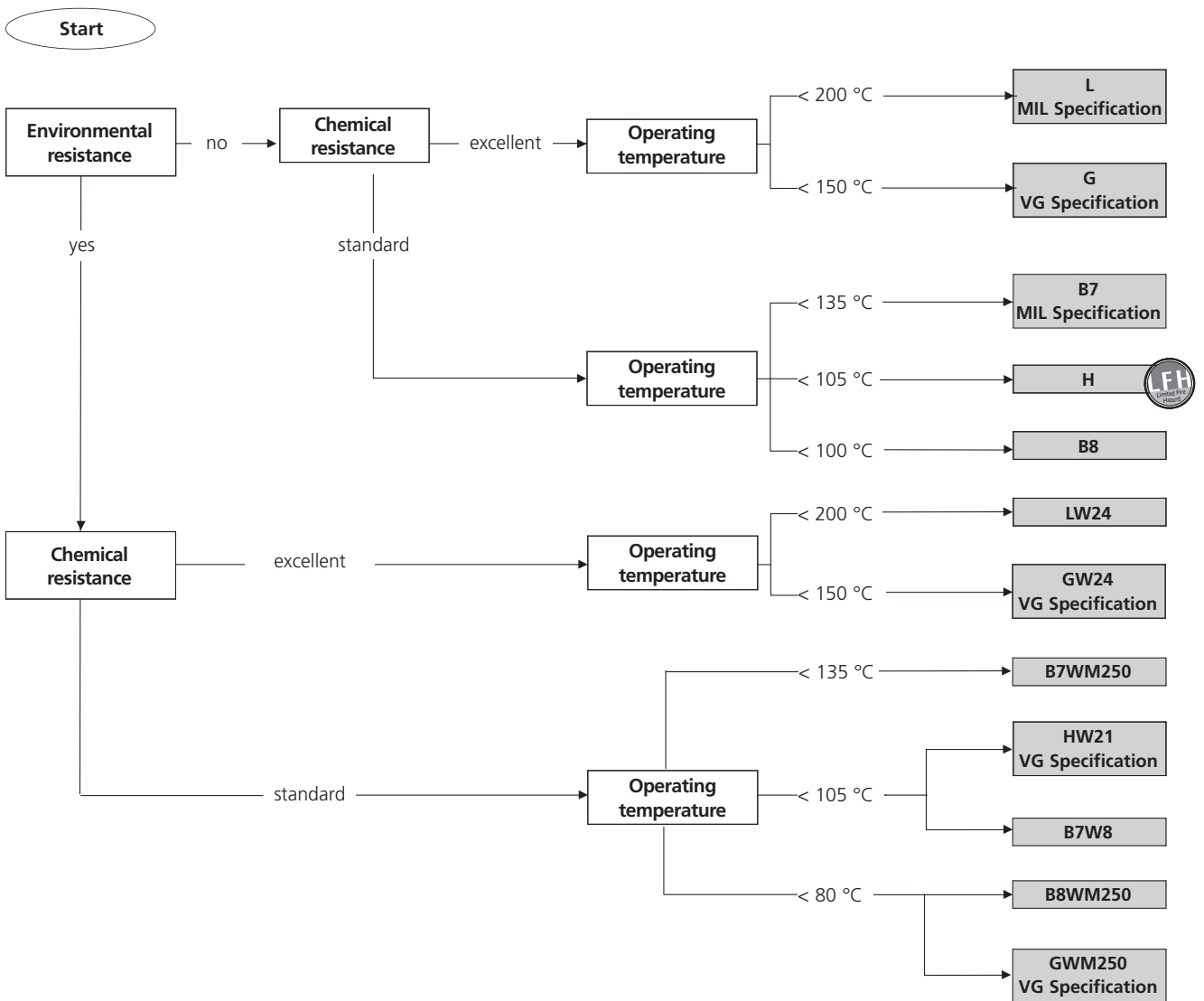

Use our flow chart to find the correct product or solution for your particular application.

Begin your search in the flow chart at the START point. You will be guided through the page according to your requirements. Using the "yes/no" and "either/or" decisions, you will be able to select the correct product or solution.

Of course, you can always call us whenever you wish on our usual telephone numbers.



Order Example

Type:

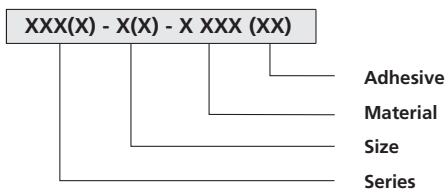

Example:

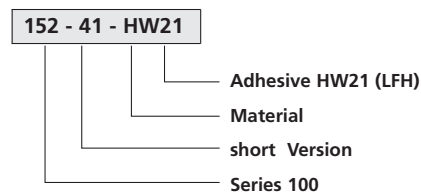



Adhesives for moulded parts

In today's competitive environment, the assembly of wire harnesses must be both fast and reliable. With conventional methods however, speed and reliability can rarely be guaranteed. Therefore you should try HellermannTyton heat shrinkable moulded shapes.

Shapes made of H material are halogen-free and self-extinguishing. The shapes are coated with a hot melt adhesive (W21) that provides a reliable environmental seal. This adhesive has a low melting point and the post-cure time is minimal, taking only 45-60 seconds. HW21 material and adhesive combination is certified according to VG 95343 parts 29 and 30.

Heatshrinkable shapes made of elastomer material G can be pre-coated with W24 epoxy adhesive. After complete recovery of the shape no additional reheating of the adhesive joints is necessary.

Since GW24 parts are very fast shrinking, the processing time of HellermannTyton shapes can be reduced to just a few seconds! GW24 moulded parts have a shelf life of 5 years under normal conditions and do not have to be stored in closed packing. GW24 material and adhesive combination is certified according to VG 95343 parts 18 and 19.

Material specifications			
Description	G*	B7	H
Material	Fluid resistant elastomer	Semi-rigid flame retarded Polyolefin	Flexible Limited Fire Hazard Polyolefin
Application	standard material; excellent resistance against petrol	good mechanical and chemical resistance	low smoke emission, halogen free
Colour	Black (BK)	Black (BK)	Black (BK)
Minimum Shrink Temperature	+135 °C	+135 °C	+135 °C
Operating Temperature	-75 °C to +150 °C	-55 °C to +135 °C , Intermittent +225 °C	-55 °C to +105 °C
Dielectric Strength	14 kV/mm to ASTM D2671	14 kV/mm to ASTM D2671	15 kV/mm
Flexibility	Semi rigid	Semi rigid	Flexible
Flammability	VG 95343	ASTM D635	VG 95343
Specification	VG 95343 Part 6, 8, 9 DEF STAN 59-97 / 3	MIL-I-81765/1 Type 1 DEF STAN 59-97 / 3	VG 95343 Part 29, 30 NAVSEA 5617649, DEF STAN 59-97/3

* standard material

Material specifications			
Description	L	-9	B8
Material	Flexible flame retardant Fluorelastomer	Polyolefin, cross-linked (POX)Modified elastomer blend	Polyolefin, Chemically cross-linked (POX)Semi-rigid flame retarded Polyolefin
Application	high temperature resistance and excellent chemical properties	standard material for low profile boots	General Purpose for 0.6/1kV systems
Colour	Black (BK)	Black (BK)	Black (BK)
Minimum Shrink Temperature	+175 °C	+135 °C	+135 °C
Operating Temperature	-55 °C to +200 °C	-55 °C to +120 °C	-55 °C to +100 °C
Dielectric Strength	9 kV/mm to ASTM D2671	20 kV/mm to ASTM D2671	15 kV/mm
Flexibility	flexible	flexible	Semi rigid
Flammability	ASTM D635	ASTM D635	ASTM D635
Specification	DEF STAN 59-97/3; MIL-I-81765/4	SCX15112	Det Norske Veritas

Adhesive specifications				
Description	W24	W21	W8	WM250
Material	High performance, pre-coat, 1 part epoxy	Modified polyamide hot melt adhesive	EVA, High performance hot melt adhesive	General purpose Hot melt adhesive
Application	Specially modified to meet military cable and harness needs	High temperature hot melt adhesive	High temperature hot melt that compliments H material	Good general purpose adhesive
Softening Point	N/A	120 °C to ASTM E28	110 °C to ASTM E28	95 °C to ASTM E28
Operating Temperature	-75 °C to +200 °C	-55 °C to +120 °C	-55 °C to +105 °C	-50 °C to +80 °C
Peel Strength	VG 95343 Part 14	VG 95343 Part 14	VG 95343 Part 14	VG 95343 Part 14
Water Absorption at 25 °C	ASTM D570	ASTM D570	ASTM D570	ASTM D570
Solvent Resistance	Very good to excellent under most conditions	Very good under most especially saline conditions	Fair under splash conditions	Fair under splash conditions
Specification	VG 95343 Part 18, 19; DEF STAN 59-97/3	VG 95343 Part 29, 30	DEF STAN 59-97/3	DEF STAN 59-97/3



Helashrink 100 Series

Straight plug-and-socket connector terminal casing. This style is used in conjunction with circular grooved adaptor, providing protection against environmental stresses. The inside lip has been designed to provide extra reinforced stress relief. Special fitting 199-4-G for audio plugs has external ribs for an improved grip.



Recovered 199-4-G, VG style shape for small audio connectors with external ribs for improved grip.



150 series boot recovered on to connector.

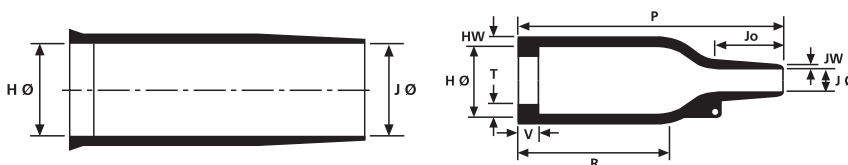

Technical Table

Article-No.	Type	Designation as per VG-Norm	H min a	H max b	J min a	J max b	P ± 10%	R ± 10%	JO ± 10%	HW ± 20%	JW ± 20%	V ± 10%	T ± 20%
401-52780	152-41-G	VG 95343 T06 A 001 A	24.0	10.5	24.0	6.0	26.0	9.0	10.0	1.6	0.5	3.0	1.0
401-52880	152-42-G	VG 95343 T06 B 001 A	24.0	10.5	24.0	6.0	38.0	21.0	10.0	1.6	0.5	3.0	1.0
401-53780	153-41-G	VG 95343 T06 A 002 A	25.0	14.0	9.0	3.5	40.0	13.0	16.0	1.8	0.5	3.0	1.0
401-53880	153-42-G	VG 95343 T06 B 002 A	25.0	14.0	9.0	3.5	55.0	28.0	16.0	1.8	0.5	3.0	1.0
401-54780	154-41-G	VG 95343 T06 A 003 A	30.0	14.0	30.0	6.0	43.0	20.0	13.0	1.8	1.0	3.0	1.0
401-54880	154-42-G	VG 95343 T06 B 003 A	30.0	14.0	30.0	6.0	55.0	32.0	13.0	1.8	1.0	3.0	1.0
401-55780	155-41-G	VG 95343 T06 A 004 A	31.0	18.0	31.0	7.0	47.0	15.0	18.0	1.8	1.0	3.0	1.0
401-55880	155-42-G	VG 95343 T06 B 004 A	31.0	18.0	31.0	7.0	67.0	35.0	18.0	1.8	1.0	3.0	1.0
401-56780	156-41-G	VG 95343 T06 A 005 A	36.0	22.5	36.0	8.5	60.0	22.0	20.0	2.0	1.0	3.0	1.0
401-56880	156-42-G	VG 95343 T06 B 005 A	36.0	22.5	36.0	8.5	80.0	42.0	20.0	2.0	1.0	3.0	1.0
401-57780	157-41-G	VG 95343 T06 A 006 A	43.0	28.0	43.0	10.0	60.0	21.0	20.0	2.2	1.0	3.0	1.7
401-57880	157-42-G	VG 95343 T06 B 006 A	43.0	28.0	43.0	10.0	79.0	41.0	20.0	2.2	1.0	3.0	1.7
401-57980	157-43-G	VG 95343 T06 C 001 A	43.0	28.0	43.0	10.0	99.0	61.0	20.0	2.2	1.0	3.0	1.7
401-58780	158-41-G	VG 95343 T06 A 007 A	60.0	35.0	60.0	16.0	90.0	32.0	38.0	3.2	1.5	3.0	1.7
401-58880	158-42-G	VG 95343 T06 B 007 A	60.0	35.0	60.0	16.0	110.0	52.0	38.0	3.2	1.5	3.0	1.7
401-58980	158-43-G	VG 95343 T06 C 002 A	60.0	35.0	60.0	16.0	130.0	72.0	38.0	3.2	1.5	3.0	1.7
401-59780	159-41-G	VG 95343 T06 A 008 A	66.0	45.0	66.0	17.0	130.0	50.0	50.0	3.8	2.0	3.0	2.0
401-59880	159-42-G	VG 95343 T06 B 008 A	66.0	45.0	66.0	17.0	150.0	70.0	50.0	3.8	2.0	3.0	2.0
401-59980	159-43-G	VG 95343 T06 C 003 A	66.0	45.0	66.0	17.0	171.0	90.0	50.0	3.8	2.0	3.0	2.0
401-60780	160-41-G	VG 95343 T06 A 009 A	82.0	58.0	82.0	27.0	137.0	37.0	62.0	3.8	3.8	3.0	2.0
401-60880	160-42-G	VG 95343 T06 B 009 A	82.0	58.0	82.0	27.0	158.0	58.0	62.0	3.8	3.8	3.0	2.0
401-60980	160-43-G	VG 95343 T06 C 004 A	82.0	58.0	82.0	27.0	213.0	113.0	62.0	3.8	3.8	3.0	2.0
401-99480	199-4-G	VG 95343 T06 A 010 A	17.5	14.0	7.0	4.3	70.0	35.0	20.0	1.8	0.5	1.5	1.0
401-13180	113-1-G	-	10.7	7.9	4.6	2.0	25.4	14.5	4.6	1.3	1.0	-	1.0
401-13480	113-4-G	-	10.7	7.9	4.6	2.0	25.4	14.5	4.6	1.3	1.0	3.0	1.0

All dimensions in mm. Subject to technical changes.

These moulded shapes are also available in the materials B7 and H, on request.

In addition, the moulded shapes can also be supplied with an inner coating or epoxy adhesives.

a as supplied
b recovered



Helashrink 100 Series

Straight plug-and-socket connector terminal casing has protection against environmental stresses for circular plug connectors, according to VG. The inside lip is used for a reinforced stress relief.



135-1-G as supplied / fully recovered.

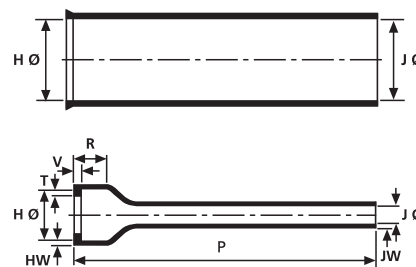

Technical Table

Article-No.	Type	Designation as per VG-Norm	H min a	H max b	J min a	J max b	P ±10% = overall length	R ± 10%	HW ± 20%	JW ± 20%	V ± 10%	T ± 10%
401-29180	129-1-G	VG95343T06D001A	22.0	12.0	22.0	6.5	76.0	12.0	1.5	1.1	3.0	1.0
401-30180	130-1-G	VG95343T06D002A	25.5	15.0	25.5	7.5	83.0	12.0	1.5	1.1	3.0	1.0
401-31180	131-1-G	VG95343T06D003A	29.0	19.0	29.0	8.5	89.0	12.0	1.8	1.1	3.0	1.0
401-32180	132-1-G	VG95343T06D004A	34.0	23.0	34.0	10.0	102.0	12.0	1.8	1.1	3.0	1.0
401-33180	133-1-G	VG95343T06D005A	37.0	30.0	37.0	11.0	108.0	14.0	2.0	1.1	3.0	1.7
401-34180	134-1-G	VG95343T06D006A	43.5	34.0	43.5	12.0	114.0	15.0	2.0	1.1	3.0	1.7
401-35180	135-1-G	VG95343T06D007A	50.0	41.0	50.0	14.5	118.0	15.0	2.3	1.4	3.0	1.7
401-36180	136-1-G	VG95343T06D008A	62.5	47.0	62.5	18.0	121.0	16.0	2.5	1.4	3.0	2.0
401-38180	138-1-G	VG95343T06D009A	69.0	60.0	69.0	20.0	127.0	16.0	2.5	1.4	3.0	2.0
401-87180	187-1-G	VG95343T06D010A	81.5	67.0	81.5	23.0	133.0	16.0	2.5	1.4	3.0	2.0

All dimensions in mm. Subject to technical changes.

These moulded shapes are also available in various materials from our range, eg, B7, H, Land J on request.

In addition, the moulded shapes can also be supplied with an inner coating from our range of hot-melt and epoxy adhesives, eg, W24, W1, W8 and WM250.

a as supplied
b recovered



177-1-G as supplied / fully recovered.

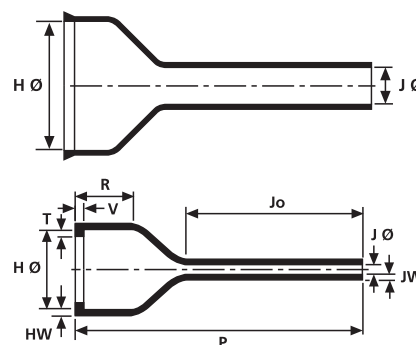

Technical Table

Article-No.	Type	Designation as per VG-Norm	H min a	H max b	J min a	J max b	P ±10% = overall length	R ± 10%	JO ± 10%	HW ± 20%	JW ± 20%	V ± 10%	T ± 10%
401-76180	176-1-G	VG95343T06D011A	19.3	13.0	6.3	2.1	60.0	11.7	37.6	1.5	1.1	3.1	1.0
401-77180	177-1-G	VG95343T06D012A	26.1	19.1	7.6	2.6	74.0	12.2	45.0	1.8	1.1	3.1	1.0
401-78180	178-1-G	VG95343T06D013A	34.2	26.0	9.6	3.1	84.0	12.2	51.1	1.8	1.1	3.1	1.0
401-79180	179-1-G	VG95343T06D014A	43.6	34.1	11.4	3.6	100.0	12.2	60.0	1.8	1.1	3.1	1.7

All dimensions in mm. Subject to technical changes.

These moulded shapes are also available in the materials B7 and H, on request.

In addition, the moulded shapes can also be supplied with an inner coating from our range of hot-melt or epoxy adhesives.

a as supplied
b recovered



Helashrink 1100 Series

Right-angle, VG style shape with rib. This style provides connector cable strain relief and can be installed directly onto connector rear thread.

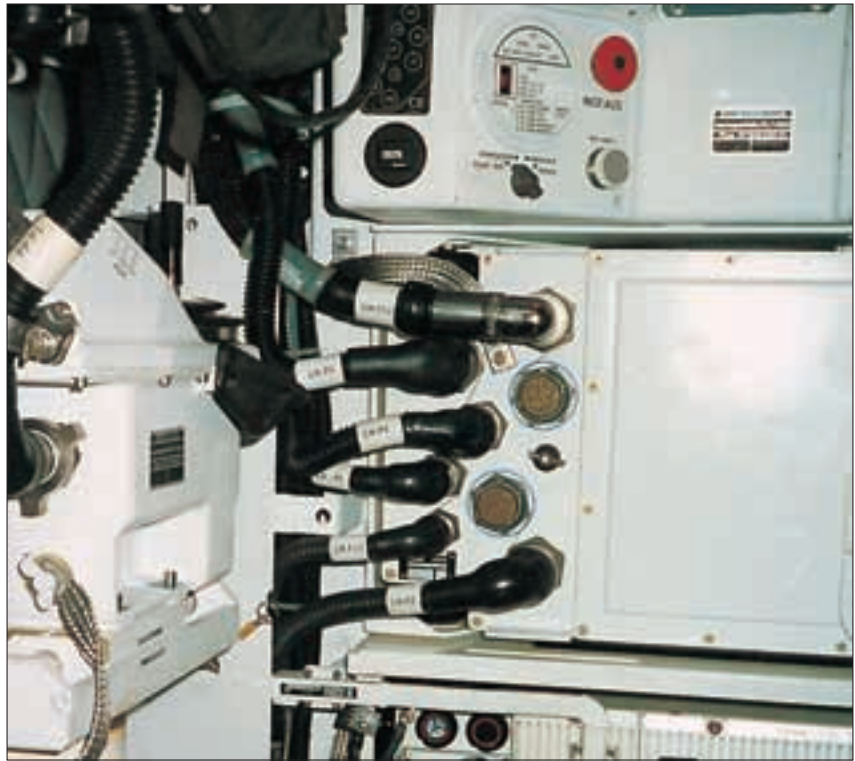

Space saving right-angle shapes used here in a military application.

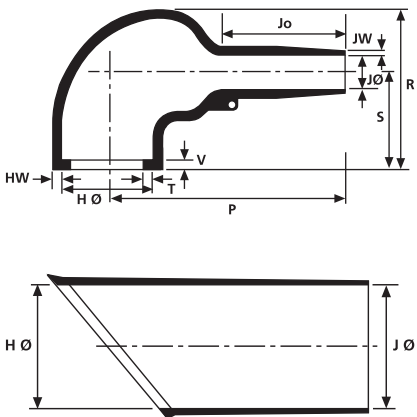

1152-4-G recovered on to a connector.

Technical Table

Article-No.	Type	Designation as per VG-Norm	H min a	H max b	J min a	J max b	P ± 10%	R ± 10%	S ± 10%	JO ± 10%	HW ± 20%	JW ± 20%	V ± 10%	T ± 20%
411-08180	1108-1-G	-	16.5	7.9	16.5	3.8	17.3	20.1	15.2	4.1	1.0	1.0	-	1.0
411-08480	1108-4-G	-	16.5	7.9	16.5	3.8	17.3	20.1	15.2	4.1	1.0	1.0	3.0	1.0
411-52480	1152-4-G	VG95343T06E001A	24.0	10.5	24.0	6.0	26.0	25.0	19.0	10.0	1.3	0.5	3.0	1.0
411-54480	1154-4-G	VG95343T06E002A	30.0	15.5	30.0	6.0	32.0	27.0	20.0	12.0	1.5	0.8	3.0	1.0
411-55480	1155-4-G	VG95343T06E003A	31.0	18.0	31.0	7.0	40.0	31.0	21.0	15.0	1.8	1.0	3.0	1.0
411-56480	1156-4-G	VG95343T06E004A	36.0	22.5	36.0	8.5	46.0	38.0	26.0	15.0	1.8	1.0	3.0	1.0
411-57480	1157-4-G	VG95343T06E005A	43.0	28.5	43.0	10.0	55.0	45.0	30.0	16.0	2.0	1.0	3.0	1.7
411-58480	1158-4-G	VG95343T06E006A	60.0	35.0	60.0	16.0	80.0	54.0	35.0	30.0	3.3	1.5	3.0	1.7
411-59480	1159-4-G	VG95343T06E007A	66.0	45.0	66.0	17.0	108.0	68.0	42.0	51.0	3.8	2.0	3.0	2.0
411-60480	1160-4-G	VG95343T06E008A	82.0	61.0	82.0	25.0	118.0	84.0	52.0	39.0	4.0	4.0	3.0	2.0

All dimensions in mm. Subject to technical changes.

These moulded shapes are also available in the materials B7 and H, on request.

In addition, the moulded shapes can also be supplied with an inner coating from our range of hot-melt or epoxy adhesives.

a as supplied
b recovered



Helashrink 1100 Series

Right-angle, low profile shape with rib, VG/Mil style, often used on airborne harnesses to achieve low profile, compact strain relief and mechanical protection.

The photo below shows a shape style that provides connector strain relief and is used in applications of partially loaded connectors with small cable diameters.



1123-1-G Supplied and recovered.

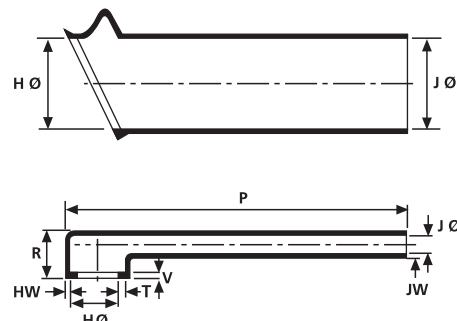

Technical Table

Article-No.	Type	Designation as per VG-Norm	H min a	H max b	J min a	J max b	P ±10% = overall length	R ± 10%	HW ± 20%	JW ± 20%	V ± 10%	T ± 10%
411-21180	1121-1-G	VG95343T06F001A	22.0	12.0	22.0	6.5	70.0	19.0	1.5	1.1	3.0	1.0
411-22180	1122-1-G	VG95343T06F002A	25.5	15.0	25.0	7.5	79.0	20.0	1.5	1.1	3.0	1.0
411-23180	1123-1-G	VG95343T06F003A	29.0	19.0	29.0	8.5	89.0	21.0	1.8	1.1	3.0	1.0
411-24180	1124-1-G	VG95343T06F004A	34.0	23.0	34.0	10.0	102.0	22.0	1.8	1.1	3.0	1.0
411-25180	1125-1-G	VG95343T06F005A	37.0	30.0	37.0	11.0	108.0	24.0	2.0	1.1	3.0	1.7
411-26180	1126-1-G	VG95343T06F006A	43.5	34.0	43.5	12.0	121.0	27.0	2.0	1.1	3.0	1.7
411-27180	1127-1-G	VG95343T06F007A	50.0	41.5	50.0	14.5	132.0	30.0	2.3	1.4	3.0	1.7
411-28180	1128-1-G	VG95343T06F008A	62.5	47.0	62.5	18.0	133.0	33.0	2.5	1.4	3.0	2.0
411-29180	1129-1-G	VG95343T06F009A	69.0	60.0	69.0	20.0	137.0	35.0	2.5	1.4	3.0	2.0
411-41180	1141-1-G	VG95343T06F010A	82.0	67.0	82.0	23.0	140.0	45.0	2.5	1.4	3.0	2.0

All dimensions in mm. Subject to technical changes.

These moulded shapes are also available in the materials B7 and H, on request.

In addition, the moulded shapes can also be supplied with an inner coating from our range of hot-melt or epoxy adhesives.

a as supplied

b recovered

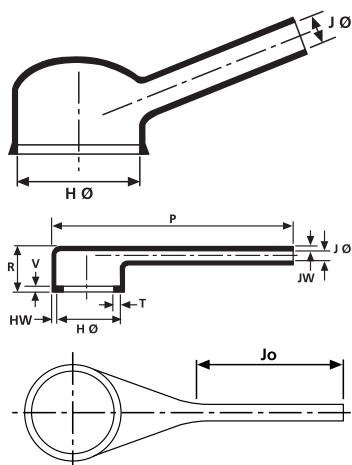

1135-1-G Supplied and recovered.

Technical Table

Article-No.	Type	Designation as per VG-Norm	H min a	H max b	J min a	J max b	P ±10% = overall length	R ± 10%	JO ± 10%	HW ± 20%	JW ± 20%	V ± 10%	T ± 10%
411-33180	1133-1-G	VG95343T06F011A	19.0	13.0	6.0	2.0	44.0	16.3	21.8	1.5	1.1	3.0	1.0
411-34180	1134-1-G	VG95343T18H001A	26.0	19.0	7.5	2.5	67.0	18.0	29.2	1.8	1.1	3.0	1.0
411-35180	1135-1-G	VG95343T06F013A	34.0	26.0	9.5	3.0	81.0	18.8	35.3	1.8	1.1	3.0	1.0
411-36180	1136-1-G	VG95343T06F014A	43.5	34.0	11.5	3.5	116.0	21.3	47.0	1.8	1.1	3.0	1.7

All dimensions in mm. Subject to technical changes.

These moulded shapes are also available in the materials B7 and H, on request.

In addition, the moulded shapes can also be supplied with an inner coating or epoxy adhesives.

a as supplied

b recovered



Helashrink 200 Series

Branching parts are used for easy, time-saving insulation of the branch point of a cable where it is split into single wires. Branching parts with hot-melt adhesive also serve to relieve the mechanical tension in cable harnesses.



Two-way outlet shape 203-1-G as supplied and recovered.

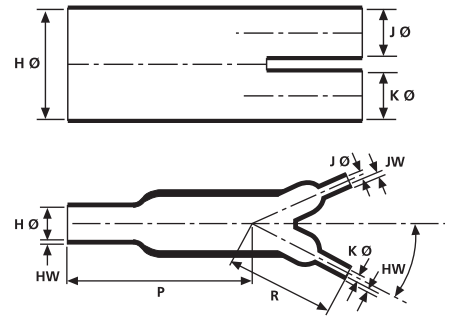

Technical Table

Article-No.	Type	Designation as per VG-Norm	H min a	H max b	J/K min a	J/K max b	P ± 10%	R ± 10%	HW ± 20%	JW/KW ± 20%
402-06180	206-1-G	VG95343T08C001A	13.0	6.0	7.0	3.0	22.0	19.0	1.5	1.0
402-12180	212-1-G	VG95343T08C005A	14.5	8.0	8.5	5.5	82.6	63.5	2.3	2.0
402-13180	213-1-G	-	17.3	7.9	11.1	7.9	83.1	64.0	2.3	2.3
402-03180	203-1-G	VG95343T08C002A	27.0	12.0	13.0	6.0	39.0	43.0	2.5	1.5
402-04180	204-1-G	VG95343T08C003A	39.0	18.0	27.0	12.0	66.0	81.0	3.1	2.5
402-01180	201-1-G	-	19.0	9.4	6.4	14.0	50.8	30.5	1.5	1.5
402-01220	201-2-G	-	31.8	9.4	15.7	6.4	50.8	30.5	1.5	1.5

All dimensions in mm. Subject to technical changes.

These moulded shapes are also available in the materials B7 and H, on request.

In addition, the moulded shapes can also be supplied with an inner coating from our range of hot-melt or epoxy adhesives.

a as supplied
b recovered

Helashrink 300 Series

Branching parts are used for easy, time-saving insulation of the branch point of a cable where it is split into single wires. Branching parts with hot-melt adhesive also serve to relieve the mechanical tension in cable harnesses.



304-1-G as supplied / fully recovered.

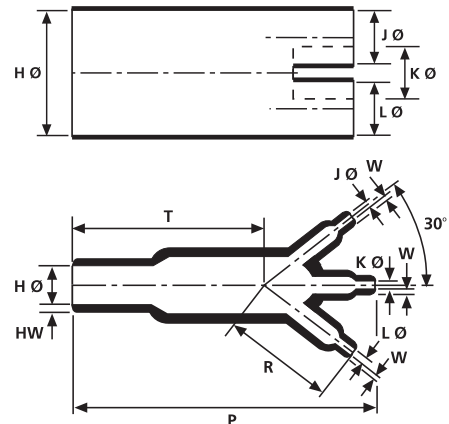

Technical Table

Article-No.	Type	Designation as per VG-Norm	H min a	H max b	J/K/L min a	J/K/L max b	P ± 10%	R ± 10%	HW ± 20%	W ± 20%	T ± 10%
403-06180	306-1-G	VG95343T08D001A	13.0	6.5	6.5	3.5	46.0	25.4	1.3	1.0	20.3
403-04180	304-1-G	VG95343T08D002A	27.0	13.5	13.0	7.0	93.0	50.3	2.5	1.5	42.9
403-10180	310-1-G	VG95343T08D003A	38.5	19.0	19.0	10.0	135.0	73.7	3.1	1.8	61.0
403-11180	311-1-G	VG95343T08D004A	55.5	25.5	27.0	12.5	192.0	103.1	4.6	3.1	88.9

All dimensions in mm. Subject to technical changes.

These moulded shapes are also available in the materials B7 and H, on request.

In addition, the moulded shapes can also be supplied with an inner coating from our range of hot-melt or epoxy adhesives.

a as supplied
b recovered



Helashrink 400 Series

Branching parts are used for easy, time-saving insulation of the branch point of a cable where it is split into single wires. Adhesive lined branching parts also serve to relieve the mechanical tension in cable harnesses.

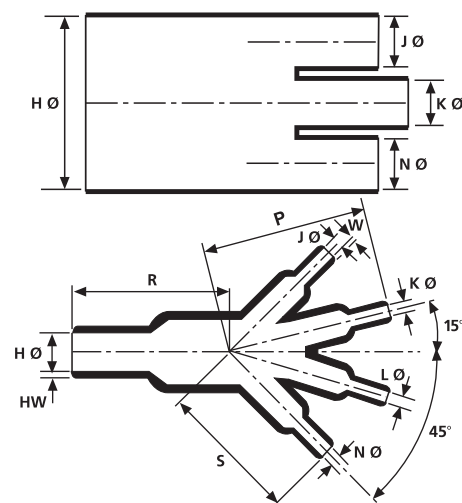

403-1-G as supplied / recovered.

Technical Table

Article-No.	Type	Designation as per VG-Norm	H min a	H max b	J/K/L/N min a	J/K/L/N max b	P ± 10%	R ± 10%	S ± 10%	HW ± 20%	W ± 10%
404-11180	411-1-G	VG95343T08E002A	19.0	10.0	9.5	5.5	36.1	35.6	32.0	1.8	1.0
404-03180	403-1-G	VG95343T08E004A	27.0	13.0	13.0	7.0	51.8	49.0	45.0	2.5	1.0
404-13180	413-1-G	VG95343T08E005A	38.6	19.0	19.0	10.0	74.9	75.0	65.3	1.8	1.0

All dimensions in mm. Subject to technical changes.

These moulded shapes are also available in the materials B7 and H, on request. In addition, the moulded shapes can also be supplied with an inner coating from our range of hot-melt or epoxy adhesives.

a as supplied
b recovered

Helashrink 1200 Series

90° (right angled) transition parts (T-joints) are used for a simple time-saving insulation of the branch point of a cable, where it is split into single wires. Adhesive lined T-joints also serve to relieve the mechanical tension and to protect against corrosion in cable harnesses.



Moulded shape 1202-1-G.

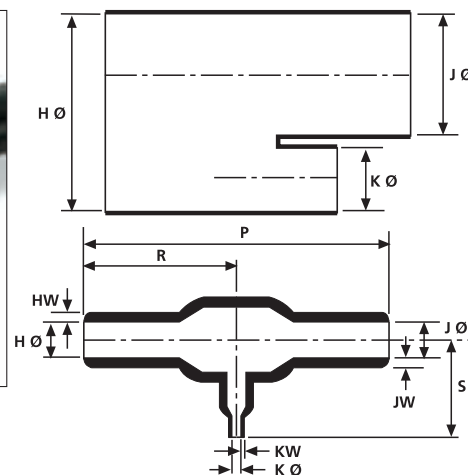

Technical Table

Article-No.	Type	Designation as per VG-Norm	H/J min a	H/J max b	K min a	K max b	P ± 10% = overall length	R ± 10%	S ± 10%	KW ± 20%	HW/JW ± 10%
412-06180	1206-1-G	VG95343T08A009A	6.6	3.0	6.6	3.0	29.7	14.7	14.7	1.0	1.0
412-03180	1203-1-G	VG95343T08A001A	13.2	6.0	6.5	3.0	52.0	26.0	19.3	1.0	1.5
412-02180	1202-1-G	VG95343T08A010A	13.2	6.1	13.2	6.1	58.7	29.2	29.2	1.5	1.5
412-05180	1205-1-G	-	17.7	8.9	7.6	3.8	50.8	25.4	25.4	1.0	1.5
412-01180	1201-1-G	VG95343T08A007A	17.7	8.9	10.1	5.1	47.5	23.6	23.6	1.0	1.5
412-09180	1209-1-G	VG95343T08A002A	27.0	12.4	13.2	6.0	108.0	54.0	38.6	1.5	2.5
412-07180	1207-1-G	VG95343T08A011A	26.9	12.4	26.9	12.4	120.1	55.9	59.9	2.5	2.5
412-04180	1204-1-G	VG95343T08A016A	13.0/6.5	7.5/4.0	6.5	4.0	56.0	33.0	19.3	1.0	1.5/1.0
412-16180	1216-1-G	VG95343T08A017A	33.0/16.5	13.0/6.5	16.5	6.5	97.0	54.0	38.5	1.5	2.5/1.5

All dimensions in mm. Subject to technical changes.

These moulded shapes are also available in the materials B7 and H, on request. In addition, the moulded shapes can also be supplied with an inner coating from our range of hot-melt or epoxy adhesives.

a as supplied
b recovered



Helashrink 1300 Series

45° transition parts (Y-joints) are used for a simple time-saving insulation of the branch point of a cable where it is divided into single wires. Y-joints with hot-melt adhesive also serve to relieve the mechanical tension in cable harnesses.

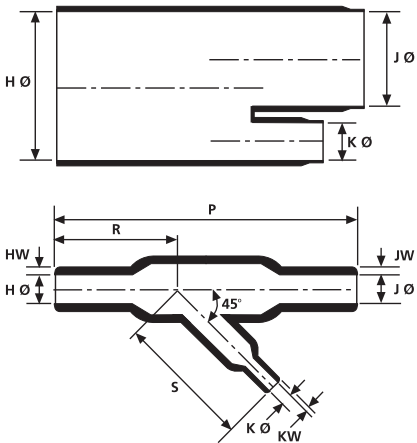

Angled T shape 1303-1-G as supplied/ recovered.

Technical Table

Article-No.	Type	Designation as per VG-Norm	H min a	H max b	J min a	J max b	K min a	K max b	P ±10%= overall length	R ± 10%	S ± 10%	KW ± 20%	HW ± 20%	JW ± 20%
413-01180	1301-1-G	VG 95343 T08 B 001 A	13.0	7.0	13.0	7.0	7.0	3.5	50.0	23.0	23.0	1.0	1.5	1.5
413-02180	1302-1-G	VG 95343 T08 B 004 A	27.0	13.0	27.0	13.0	7.0	3.5	93.0	41.0	36.0	1.0	2.5	2.5
413-03180	1303-1-G	VG 95343 T08 B 002 A	27.0	14.0	27.0	14.0	13.0	7.5	145.0	70.0	54.0	1.5	2.5	2.5
413-13180	1313-1-G	VG 95343 T06 B 009 A	28.5	13.5	27.0	13.5	27.0	13.5	150.0	70.0	80.0	2.5	2.5	2.5
413-11180	1311-1-G*	VG 95343 T08 B 003 A	30.4	15.0	30.4	15.0	20.3	10.0	83.0	32.0	51.0	1.8	2.5	2.5

All dimensions in mm. Subject to technical changes. * 30° transition part

These moulded shapes are also available in the materials B7 and H, on request.

In addition, the moulded shapes can also be supplied with an inner coating from our range of hot-melt or epoxy adhesives.

a as supplied
b recovered

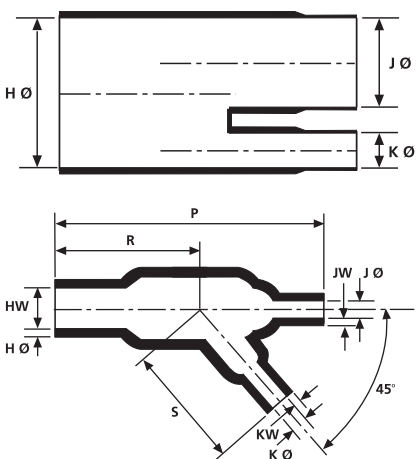

Angled T shape 1306-1-G as supplied/ recovered.

Technical Table

Article-No.	Type	Designation as per VG-Norm	H min a	H max b	J min a	J max b	K min a	K max b	P ±10%= overall length	R ± 10%	S ± 10%	KW ± 20%	HW ± 20%	JW ± 20%
413-06180	1306-1-G	VG95343T06B010A	13.0	6.0	6.5	3.0	6.5	3.0	45.0	23.0	21.5	1.5	1.0	1.0

All dimensions in mm. Subject to technical changes.

These moulded shapes are also available in the materials B7 and H, on request.

In addition, the moulded shapes can also be supplied with an inner coating from our range of hot-melt or epoxy adhesives.

a as supplied
b recovered



Helashrink 313C Series Convolute boot, low profile with adapter lip

This style is used with a circular grooved adapter to provide strain relief and if adhesive is used, excellent environmental sealing can be achieved.

The convolute design provides the flexibility to accommodate different cable outlet angles.



313C722-774 series as supplied / recovered.

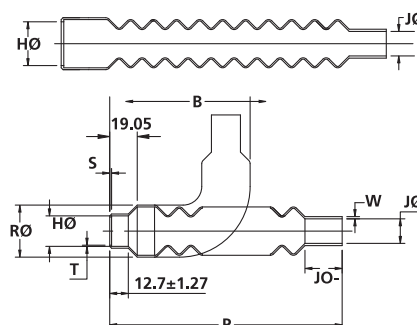

Technical Table

Article-No.	Type	H DIA min a	H DIA max b	J DIA min a	J DIA max b	P ± 10% b	R max b	JO ± 1.8	W min b	B nom b	T ± 0.5	S ± 0.5
422-00001	313C722-9	14.2	6.9	11.1	4.8	120.6	21.1	17.3	1.5	62.4	1.3	1.5
422-00101	313C732-9	22.4	11.7	17.7	8.1	133.3	26.5	19.8	1.5	67.8	1.3	1.5
422-00201	313C743-9	34.0	17.5	26.9	12.7	146.0	32.7	22.3	1.5	73.4	1.3	1.8
422-00302	313C753-9	44.2	22.3	36.5	17.5	158.7	37.8	25.4	1.5	78.2	1.3	1.8
422-00400	313C764-9	53.8	27.9	45.7	22.3	171.4	42.9	28.4	1.5	82.8	2.0	1.8
422-00501	313C774-9	77.2	40.6	54.6	22.8	236.2	62.2	35.4	1.5	138.4	2.0	2.0

a as supplied
b recovered

All dimensions in mm. Subject to technical changes.

Helashrink 333F Series Right angle, boot 90°, low profile with adapter lip

The boot provides connector strain relief in applications with partially loaded connectors, resulting in small cable diameters requiring a high shrink ratio.



333F322-385 series as supplied / recovered.

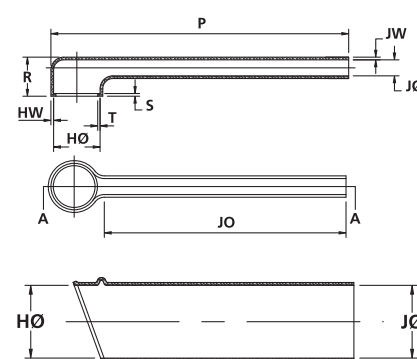

Technical Table

Article-No.	Type	H DIA min a	H DIA max b	J DIA min a	J DIA max b	P ± 10% b	R ± 15%	T ± 0.8	JO ± 10% b	HW ± 1.5	JW ± 0.8	S ± 1.5
422-30000	333F322-9	23.8	9.9	17.2	6.6	105.1	18.5	1.3	87.6	1.5	1.5	1.5
422-30004	333F332-9	27.1	13.2	20.8	7.6	115.8	19.8	1.3	99.0	1.5	1.5	1.5
422-30100	333F343-9	30.9	18.5	4.3	8.9	146.3	20.8	1.3	114.3	1.7	1.7	1.7
422-30200	333F353-9	35.3	21.6	28.7	10.1	172.2	21.8	1.3	132.5	1.7	1.5	1.7
422-30301	333F364-9	38.8	27.9	31.4	10.9	185.1	24.1	1.8	143.7	1.7	1.5	1.7
422-30400	333F374-9	45.2	34.0	38.3	12.1	213.6	27.4	1.8	169.0	1.7	1.5	1.7
422-30500	333F385-9	51.5	41.1	44.4	15.0	224.5	29.4	1.7	173.2	1.7	1.7	1.7

a as supplied
b recovered

All dimensions in mm. Subject to technical changes.



Helashrink 313E Series Shim boot, low profile, no adapter lip

This part is normally used to build up, or shim a cable diameter to facilitate a better fit for components in a cable harness.



313E445-457 series as supplied / recovered.

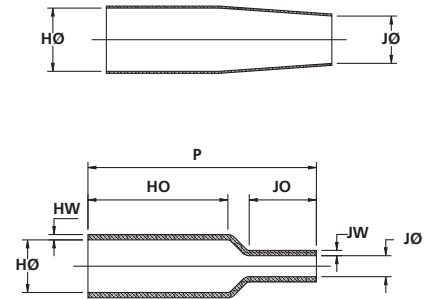

Technical Table

Article-No.	Type	H DIA min a	H DIA max b	J DIA min a	J DIA max b	P ± 10% b	JO ± 10% b
422-10000	313E445-9	14.7	12.7	11.1	3.3	63.5	15.7
422-10200	313E455-9	25.7	22.1	11.2	3.3	53.3	15.7
422-10100	313E447-9	20.8	14.7	20.6	9.9	63.5	16.5
422-10300	313E457-9	25.7	22.1	20.6	9.9	53.3	14.0

All dimensions in mm. Subject to technical changes.

a as supplied
b recovered

Helashrink 313F Series Straight boot, low profile with adapter lip

This boot provides strain relief in applications with partially loaded connectors, resulting in small cable diameters requiring a high shrink ratio.



313F322-396 series as supplied / recovered

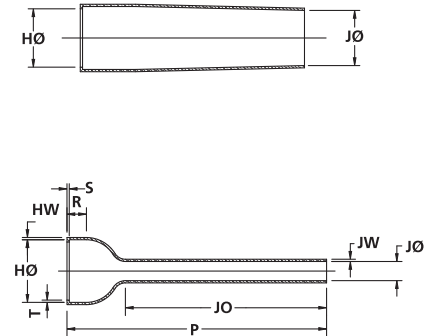

Technical Table

Article-No.	Type	H DIA min a	H DIA max b	J DIA min a	J DIA max b	P ± 10% b	R ± 15%	T ± 0.8	JO ± 10% b	HW ± 1.5	JW ± 0.8	S ± 1.5
422-20000	313F322-9	23.8	9.9	17.2	6.6	105.9	11.6	1.3	86.3	1.5	1.5	1.5
422-20100	313F332-9	27.1	13.2	20.8	7.6	121.1	12.1	1.3	98.5	1.5	1.5	1.5
422-20200	313F343-9	30.9	18.5	24.3	8.9	138.6	12.1	1.3	112.7	1.7	1.5	1.7
422-20300	313F353-9	35.6	22.1	28.7	10.1	159.5	12.1	1.3	130.8	1.7	1.5	1.7
422-20400	313F364-9	38.8	28.2	31.4	10.9	177.8	13.9	1.8	142.2	1.7	1.5	1.7
422-20500	313F374-9	42.2	32.2	38.3	12.7	203.2	15.2	1.8	163.0	1.7	1.5	1.7
422-20600	313F385-9	51.5	45.4	45.4	14.9	203.2	15.2	1.8	157.7	1.7	1.7	1.7
422-20700	313F396-9	62.7	45.4	53.3	16.7	228.6	16.0	1.8	153.1	1.7	1.7	1.7

All dimensions in mm. Subject to technical changes.



Helashrink 412H Series Transition, side breakout, low profile

This style provides connector cable strain relief and is used in conjunction with a circular grooved adapter.



412H622-625 as supplied / recovered.

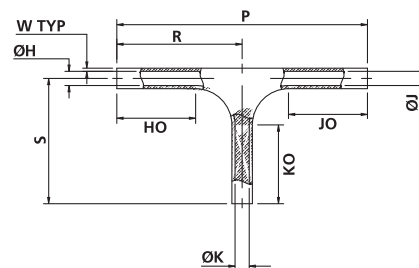
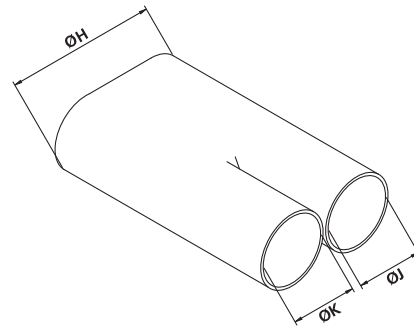

Technical Table

Article-No.	Type	H DIA min a	H DIA max b	J DIA min a	J DIA max b	HO,JO & KO ± 10% b	P nom b	W nom b	R&S nom b
422-40000	412H622-9	19.8	6.6	13.2	6.6	25.4	80.7	1.0	40.3
422-40100	412H623-9	34.2	11.4	22.8	6.6	41.1	120.3	1.3	60.1
422-40200	412H624-9	60.1	20.0	40.1	20.0	63.5	175.7	1.5	87.8
422-40300	412H625-9	83.3	33.2	54.8	33.2	88.9	242.3	1.7	121.1

All dimensions in mm. Subject to technical changes.

a as supplied
b recovered

Helashrink 492H Series Transition 1 to 2 cables, Y, low profile

This style provides strain relief, sealing and mechanical protection on cable harness break-outs or transitions.



492H412-415 series as supplied / recovered.

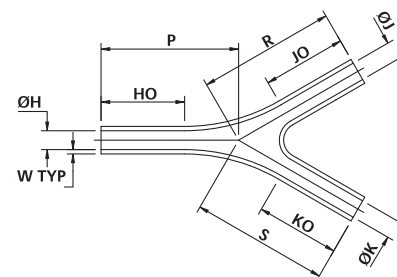
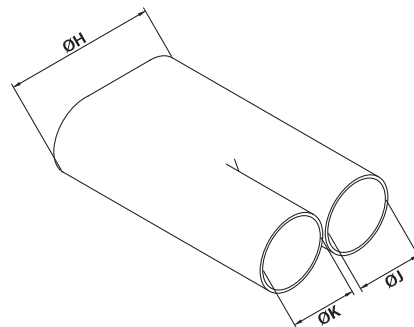

Technical Table

Article-No.	Type	H DIA min a	H DIA max b	HO,JO & KO ± 15% b	W nom b	P,R&S nom b	J & K DIA min a	J & K DIA max b
422-50000	492H412-9	19.8	6.6	25.4	1.0	40.6	13.2	6.6
422-50101	492H413-9	34.2	11.4	41.1	1.3	62.9	22.8	11.4
422-50202	492H414-9	60.1	20.0	63.5	1.5	94.7	40.1	20.0
422-50302	492H415-9	83.3	33.2	49.7	1.7	133.8	54.8	33.2
422-50200	492H414-9-01	60.1	20.0	31.7	1.5	94.7	40.1	20.0
422-50300	492H415-9-01	83.3	33.2	49.7	1.7	94.7	54.8	33.2

All dimensions in mm. Subject to technical changes.

a as supplied
b recovered



Helashrink 573H Series Transition, 1 to 3 cables, low profile

This style provides strain relief, sealing and mechanical protection on cable harness breakouts or transitions.



573H532-535 series as supplied / recovered.

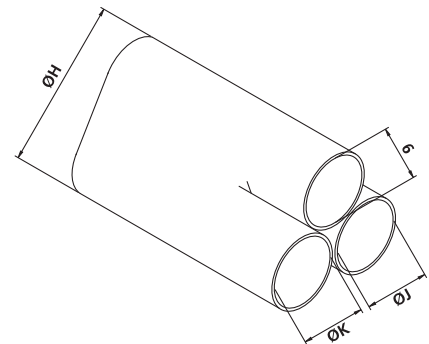
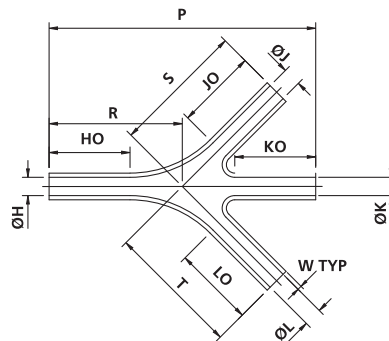

Technical Table

Article-No.	Type	H DIA min a	H DIA max b	P nom b	R,S&T nom b	W nom b	J,K & L DIA min a	J,K & L Diamete r max b	HO,JO, KO & LO ± 3.8
422-60000	573H532-9	19.8	6.6	85.8	42.9	1.0	13.2	6.6	25.4
422-60100	573H533-9	34.2	11.4	135.6	67.8	1.3	20.5	11.4	41.1
422-60202	573H534-9	60.1	20.0	207.2	103.6	1.5	36.0	20.0	27.6
422-60302	573H535-9	99.8	33.2	294.6	147.3	1.7	54.8	33.2	88.9
422-60200	573H534-9-01	60.1	20.0	135.6	67.8	1.5	36.0	20.0	27.6
422-60300	573H535-9-01	99.8	33.2	207.2	103.6	1.7	54.8	33.2	45.4

a as supplied
b recovered

All dimensions in mm. Subject to technical changes.



Two-component epoxy resin adhesive V9500

This high performance, VG-approved, two part epoxy adhesive has been developed to meet the military requirements associated with heat shrinkable components for wire and cable harnesses. It has a very good resistance against most solvents and fuels, even at elevated temperatures. The two-part epoxy adhesive is available in two different packages.

When heat is applied during the shrinking of the moulded shape the two part components react, which results in a high performance bond.



Two-component epoxy adhesive V9500.

Material Data

Material	Epoxy resins (EP)
Colour	Black (BK)
Curing Temperature	+135 °C
Curing Time	24 hours at +25 °C, 2 hours at +85 °C
Operating Temperature	-75 °C to +150 °C
Specification	VG 95343 T15 DA



V9500 applicator gun

The V9500 dosing gun allows for clean processing and individual metering. It is employed in conjunction with the dual cartridges 627-95002.

The V9500 lockable cartridges are available with or without the processing set. The processing set is available in two versions (see table for contents).

The cartridges can be re-used even after a lapse of several days, because the closure prevents the adhesive from hardening.



The V9500 applicator gun guarantees the clean and precise coating of special fittings.

Technical Table

Article-No.	Type	Designation as per VG-Norm	Content
627-95001	V9500 epoxy adhesive kit	VG 95343 T15 A 001 A	1 x dual cartridge (50g), 5 x mixing pots, 5 x mixing sticks, 5 x emery papers
627-95010	V9500 epoxy adhesive kit	VG 95343 T15 A 002 B	1 x dual cartridge (50g), 1 x mixing pot, 1 x mixing stick, 1 x emery paper, 3 x mixing nozzles
627-95002	V9500 Duo pack	VG 95343 T15 A	Two-component adhesive cartridge
627-95003	V9500 Applicator gun	VG 95343 T15 DA	Applicator gun
627-95004	V9500 Nozzle	VG 95343 T15 MA	Mixing nozzle

Subject to technical changes.



Please note! Not every product listed carries these approvals! For Product Specific Approvals please refer to the Appendix.



HEK Cable End Caps

Features and Benefits

End caps are used to seal cables during storage or transportation. HEK end caps can be used as an insulating cap for live LV cables (0.6/1kV), and the cap is marked with a lightning flash to indicate a live circuit. The adhesive lining provides an excellent environmental seal.

End caps can be fitted with air valves for certain pressurised cable applications.

The high shrink ratio minimises the number of end cap sizes needed.

Application

End caps are suitable for use on both polymeric and paper insulated, lead jacketed cables which may include aluminium or steel armouring.



The appropriate end cap for every cable diameter, and cable types.

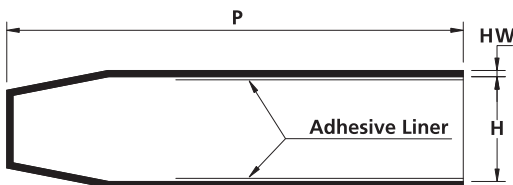

HEK

Material Data	
Material	Polyolefin, Chemically cross-linked (POX)
Colour	Black (BK)
Shrink Ratio	up to 3:1
Minimum Shrink Temperature	+135 °C
Operating Temperature	-55 °C to +80 °C
Dielectric Strength	15 kV/mm
Flammability	ASTM D635



Technical Table

Article-No.	Type	Recomm. application		H min a	H max b	Fully recovered	
		From	To			P ± 10%	HW ± 20%
HEK Standard Range							
416-12046	1612-1-B8W	4.0	8.0	10.0	4.0	33.5	2.0
416-13054	1613-1-B8W	8.0	16.0	20.0	7.5	55.3	2.3
416-14047	1614-1-B8W2	16.0	32.0	40.0	15.0	90.0	3.0
416-15035	1615-1-B8W2	26.0	51.0	63.0	25.0	143.0	3.3
416-15070	1615-2-B8W2	26.0	44.0	55.0	25.0	143.0	3.3
416-17033	1617-1-B8W2	32.0	61.0	76.0	30.0	158.0	4.0
416-16053	1616-1-B8W2	48.0	80.0	100.0	45.0	162.0	4.0
416-16110	1616-7-B8W	48.0	100.0	125.0	45.0	162.0	4.0
HEK Special Range							
416-18019	1618-1-B8W	6.0	11.0	14.0	6.0	55.3	2.3
416-01013	1601-1-B8W	10.0	19.0	23.8	9.4	89.0	2.0
416-20023	1620-1-B8W	13.0	28.0	35.0	12.7	184.0	3.3
416-08012	1608-1-B8W	70.0	130.0	159.0	63.5	127.0	3.3

a as supplied
b recovered

All dimensions in mm. Subject to technical changes.



HEV Cable Breakout Boots

Features and Benefits

Cable breakout boots are designed for insulating and sealing a cable crotch, or conduit system, and provide excellent resistance to abrasion and weathering.

Application

Cable breakouts are manufactured from a tough cross-linked polyolefin containing a flame retardant. This allows the breakouts to be used for both interior and exterior applications. They offer excellent electrical and mechanical protection.

Cable breakouts are supplied with an adhesive inner coating for reliable environmental sealing, and are available for 2, 3, 4, 5 and 6 core cables.

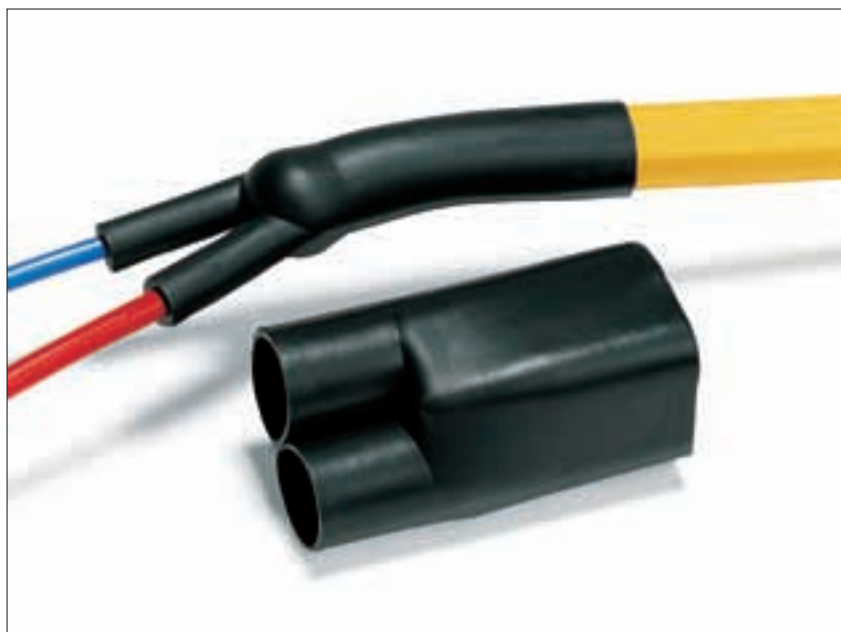

HEV breakout boot for two-core cable.

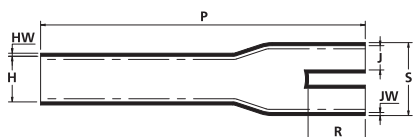

HEV breakout boot



Please note! Not every product listed carries these approvals! For Product Specific Approvals please refer to the Appendix.

Material Data

Material	Polyolefin, Chemically cross-linked (POX)
Colour	Black (BK)
Shrink Ratio	up to 3:1
Dielectric Strength	15 kV/mm
Minimum Shrink Temperature	+135 °C
Operating Temperature	-55 °C to +80 °C
Flammability	ASTM D635
Specification	Det Norske Veritas



Technical Table

Article-No.	Type	Recomm. application (mm ²)		H min a	H max b	J min a	J max b	Recovered				
		from	to					P ± 10%	R ± 10%	S nom	HW ± 20%	JW ± 20%
2 Finger Breakout Boot												
402-16007	216-1-B8W	2.5	10.0	21.0	9.4	9.0	2.8	76.5	20.0	15.0	1.6	1.6
402-23058	223-2-B8W	4.0	35.0	33.0	9.4	17.5	4.1	94.0	30.0	20.0	1.5	1.2
402-18051	218-2-B8W	50.0	150.0	49.0	22.9	20.0	7.6	119.0	34.0	30.0	3.2	3.2
402-19032	219-2-B8W	185	400	87.0	38.1	43.0	12.7	141.5	42.5	44.0	3.8	3.8
3 Finger Breakout Boot												
403-18046	318-2-B8W	4.0	16.0	25.0	9.1	9.0	3.0	76.5	20.0	16.0	2.5	2.5
403-19056	319-2-B8W	16.0	35.0	31.0	17.5	15.0	4.6	93.5	28.5	23.0	2.9	2.9
403-20031	320-2-B8W	50.0	150.0	63.0	22.5	26.0	9.0	180.0	44.0	37.0	3.0	2.0
403-24016	324-1-B8W	150	300.0	90.0	34.0	35.0	14.0	200.0	50.0	54.0	3.0	2.0
403-42006	342-1-B8W2	185	400	110.0	35.0	40.0	17.5	230.0	45.0	55.0	4.0	3.5
403-41005	341-1-B8W2	240	400.0	125.0	59.0	50.8	25.4	283.0	71.0	75.0	3.8	3.8
4 Finger Breakout Boot												
404-42022	442-1-B8W	2.5	10.0	28.0	9.0	9.0	1.8	78.0	17.0	20.0	2.7	2.0
404-08022	408-2-B8W2	4.0	35.0	35.0	12.0	15.0	3.0	95.0	24.0	22.0	2.5	2.0
404-09021	409-2-B8W2	35.0	70.0	47.4	22.9	21.5	6.4	165.0	38.1	38.1	4.1	3.3
404-18020	418-4-B8W2	70.0	150.0	60.0	22.9	30.0	6.4	202.0	38.1	38.0	4.1	3.3
404-44010	444-1-B8W2	150	300.0	78.7	35.6	38.1	12.5	240.0	55.0	55.0	4.0	3.5

All Dimensions in mm, except for "mm²". Subject to technical changes.

a as supplied
b recovere



Helashrink 500 Series

Cable breakout boots are designed for insulating and sealing a cable crotch, or conduit system, and provide excellent resistance to abrasion and weathering.

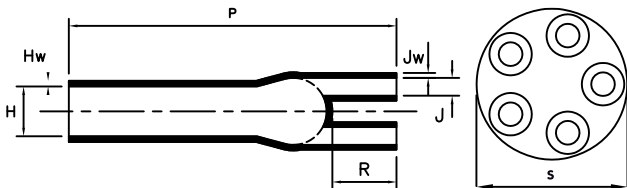

Helashrink 500 Series supplied and recovered.

Technical Table

Article-No.	Type	H min a	H max b	J min a	J max b	P ± 10%	R ± 10%	HW ± 20%	S nom	JW ± 20%
405-08029	508-3-B8	89.0	24.5	33.0	7.5	180.0	30.0	3.5	48.0	3.0
405-08030	508-3-B8W	89.0	24.5	33.0	7.5	180.0	30.0	3.5	48.0	3.0

a as supplied
b recovered

All dimensions in mm. Subject to technical changes.

These moulded shapes can also be supplied with an inner coating of high temperature hot melt (W8) or epoxy adhesive (W24). Also available in G and H materials, upon request.

Helashrink 600 Series

Cable breakout boots are designed for insulating and sealing a cable crotch, or conduit system, and provide excellent resistance to abrasion and weathering.

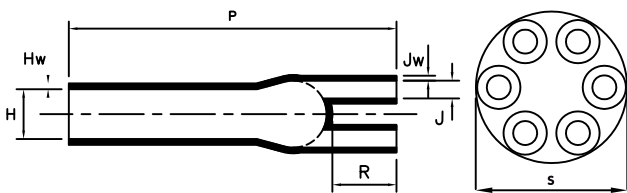

Helashrink 600 Series supplied and recovered.

Technical Table

Article-No.	Type	H min a	H max b	J min a	J max b	P ± 10%	R ± 10%	HW ± 20%	S nom	JW ± 20%
406-08018	608-2-B8	61.0	37.0	21.0	9.0	152.0	56.0	3.2	46.0	3.2
406-08019	608-2-B8W	61.0	37.0	21.0	9.0	152.0	56.0	3.2	46.0	3.2
406-09010	609-2-B8	40.0	16.0	12.0	4.0	75.0	20.0	2.5	25.0	1.5
406-09020	609-2-B8W	40.0	16.0	12.0	4.0	75.0	20.0	2.5	25.0	1.5

a as supplied
b recovered

All dimensions in mm. Subject to technical changes.

These moulded shapes can also be supplied with an inner coating of high temperature hot melt (W8) or epoxy adhesive (W24). Also available in G and H materials, upon request.



CABLE JOINTS, CABLE TERMINATIONS, CABLE GLANDS, CABLE CLEATS
FEEDER PILLARS, FUSE LINKS, ARC FLASH, CABLE ROLLERS, CUT-OUTS

11KV 33KV CABLE JOINTS & CABLE TERMINATIONS
FURSE EARTHING
www.cablejoints.co.uk
Thorne and Derrick UK
Tel 0044 191 490 1547 Fax 0044 191 477 5371
Tel 0044 117 977 4647 Fax 0044 117 9775582