

Assembly Instructions for cable gland: 501/453/UNIV Exd IIC/Exe II/ExtD

HAWKE
International

Assembly Instructions
AI 300 / Issue L - 08/06

Operating temperature range -60°C +80°C

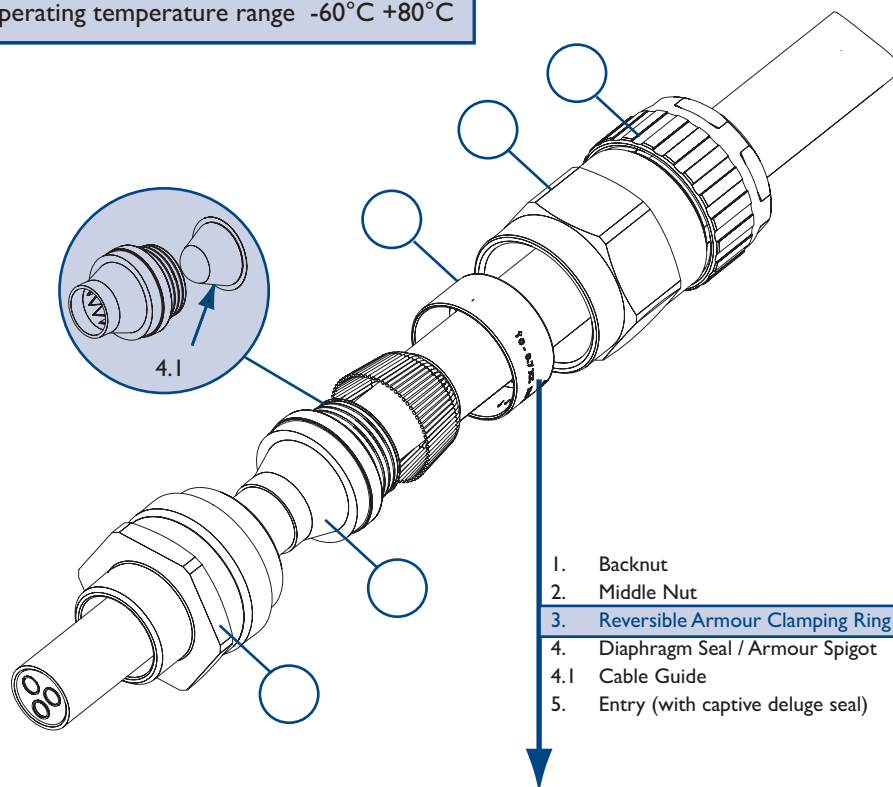

1. Backnut
2. Middle Nut
3. Reversible Armour Clamping Ring (RAC)
4. Diaphragm Seal / Armour Spigot
- 4.1 Cable Guide
5. Entry (with captive deluge seal)

Certification Details

Gland Type: 501/453/UNIV Exd IIC/Exe II/ExtD
Baseefa No: 06ATEX0057X Ⓢ II 2 GD A21 IP66 Ⓒ
IECEX No: BAS06.0014X
CEPEL No: CEPEL-EX-063/2001X
GOST R No: POCC GB.ГБ05.В01128
CSA No: 1015065 (LR 78713-7)

Reversible Armour Clamping Ring (RAC)

General identification ring orientation for:

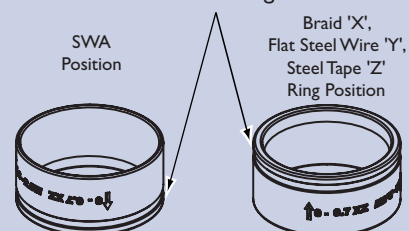

IMPORTANT: The arrowhead indicating the correct armour thickness or type should point towards the equipment

Note: Cable acceptance sizes are marked on the diaphragm seal, clamping ring and backnut.

Cable Preparation

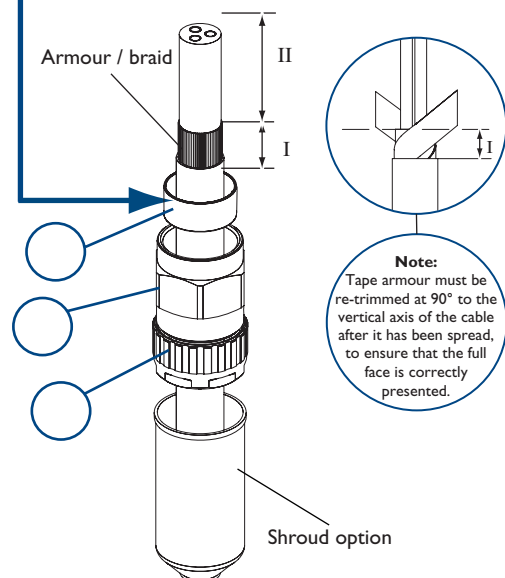

A Strip cable to suit equipment as shown above and expose the armour / braid 'I'.
'I' = 20mm for cable gland sizes O_s to C
'I' = 25mm for cable gland sizes C₂ to F
'II' = to suit equipment.
If required, fit shroud

Gland Preparation

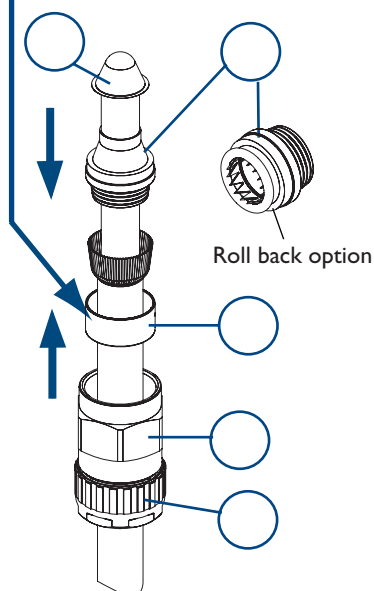

B Push the cable through the diaphragm seal / armour spigot ④. Pre-fitted cable guide ④.1 can now be discarded. The diaphragm seal can be rolled back to ease assembly if required. Spread armour / braid over the diaphragm seal / armour spigot ④ until the end of the armour / braid is up against the shoulder of the armour cone. Position the armour clamping ring ③.

C Place the entry ⑤ and position over the diaphragm seal / armour spigot ④. Move the sub-assembly ① and ② up to meet the entry ⑤.

Safety First

Hawke International is a division of Hubbell Ltd.
Registered No. 669157 in England. Registered Office:
Mitre House, 160 Aldersgate Street, London EC1A 4DD.
A member of the Hubbell Group of Companies

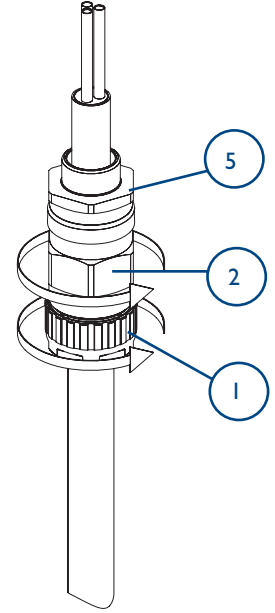
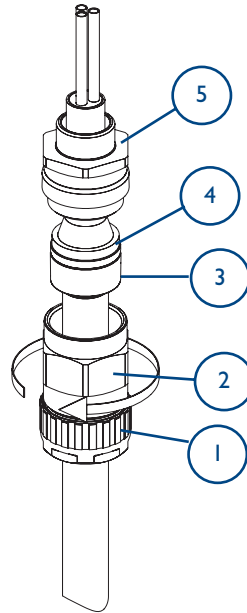
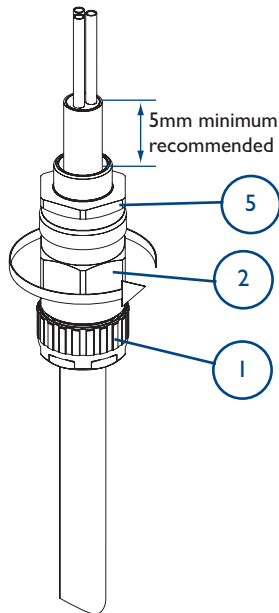

D
Hold the entry ⑤ in position with a spanner / wrench to prevent rotation. Hand tighten the middle nut ② to the entry ⑤ and turn a further 1/2 to 3/4 of a turn with a spanner / wrench.

IMPORTANT: Support the cable to prevent it from twisting. To ease wiring inside the enclosure, it may be beneficial to strip the inner sheath of the cable as shown above.

E
Unscrew the middle nut ② and visually inspect that the armour / braid has been successfully clamped between the diaphragm seal / armour spigot ④ and the armour clamping ring ③. If armour / braid not clamped, repeat assembly.

F
Reassemble middle nut ② onto the entry component ⑤. Tighten up the middle nut ② until hand tight, then using a wrench / spanner, turn the nut through 1/4 turn. Tighten the backnut ① to form a seal around the cable, then tighten a further full turn using a wrench / spanner. Ensure that the middle nut ② does not rotate when tightening the backnut ①.

Note: The deluge seal on this gland locates on assembly and requires no further action. Locate shroud over cable gland, if applicable.



CABLE JOINTS, CABLE TERMINATIONS, CABLE GLANDS, CABLE CLEATS
FEEDER PILLARS, FUSE LINKS, ARC FLASH, CABLE ROLLERS, CUT-OUTS

11KV 33KV CABLE JOINTS & CABLE TERMINATIONS
FURSE EARTHING
www.cablejoints.co.uk
Thorne and Derrick UK

Tel 0044 191 490 1547 Fax 0044 191 477 5371
Tel 0044 117 977 4647 Fax 0044 117 9775582

SCHEDULE OF LIMITATIONS:

1. The cable glands when used with braided cable types are only suitable for use with fixed apparatus, the cable for which must be effectively clamped and cleated elsewhere.
2. This cable gland has an operating temperature range of -60°C to +80°C.
3. A seal must be formed between the equipment and the cable gland to maintain the appropriate degree of protection against ingress of dust, solid objects and water.

ACCESSORIES:

Before cable gland assembly or stripping of the cable gland assembly, consideration should be given to any cable gland accessories that may be required, such as: -

- Shroud, to offer additional corrosion protection.
- Locknut, to secure cable glands into position.
- Sealing washer, to offer additional ingress protection of the enclosure at the cable gland entry.
- Earthtag, to provide an external armour / braid bonding point.
- Serrated washer, to dampen any vibrations that may loosen the locknut or cable gland assembly.