



WWW.CABLEJOINTS.CO.UK
THORNE & DERRICK UK
TEL 0044 191 490 1547 FAX 0044 477 5371
TEL 0044 117 977 4647 FAX 0044 977 5582
WWW.THORNEANDDERRICK.CO.UK

Euromold

a Nexans company



Medium voltage separable
connectors and bushings
- Interface D -

Catalogue 2006



EUROMOLD

Euromold is the leading European specialised designer, manufacturer and distributor of prefabricated cable accessories for medium voltage energy distribution. Euromold provides a complete range of accessories for underground cables: pre-moulded EPDM or silicone rubber connectors, terminations and joints for cables and epoxy bushings for transformers and switch gear, as well as a large range of cold-shrinkable terminations and joints from 12 to 42 kV.

Euromold is also the manufacturer of electrical components for the high voltage accessories of the Nexans group.

ISO 9001 Certificate

Since 1992, Euromold's commitment to quality is demonstrated by its ISO 9001 certification.

International standards

All our products meet the International standards like CENELEC HD 629.1, CENELEC EN 50180, IEC 137, IEEE 386 & 404... or country specifications. Official certificates, CESI, KEMA, ATEX... prove the conformity of our products. Long duration tests of existing or new products are continuously performed in our test fields.

Laboratory accreditation

Since June 2000, Euromold's independent ELAB laboratory obtained the BELTEST accreditation no.192-T-ISO 17025 conform with the European standards for laboratories ISO 17025 for electrical testing of medium voltage cable accessories according to the International standards IEC 61442 and HD 629.

While every care is taken to ensure that the information contained in this publication is correct, no legal responsibility can be accepted for any inaccuracy. EUROMOLD NV reserves the right to alter or modify the characteristics of its products described in this catalogue as standards and technology evolve.

SEPARABLE CONNECTORS AND BUSHINGS INTERFACE D

Table of contents

- 676LRA - tee connector
- 670AR-2 - equipment bushing
- 672T1 - equipment bushing
- 672TBC - in-air bushing
- Accessories
- Possible arrangements
- Fixings for equipment bushings

Interface D

Dimensions according to
European CENELEC EN
501810 and 50181 (in mm).

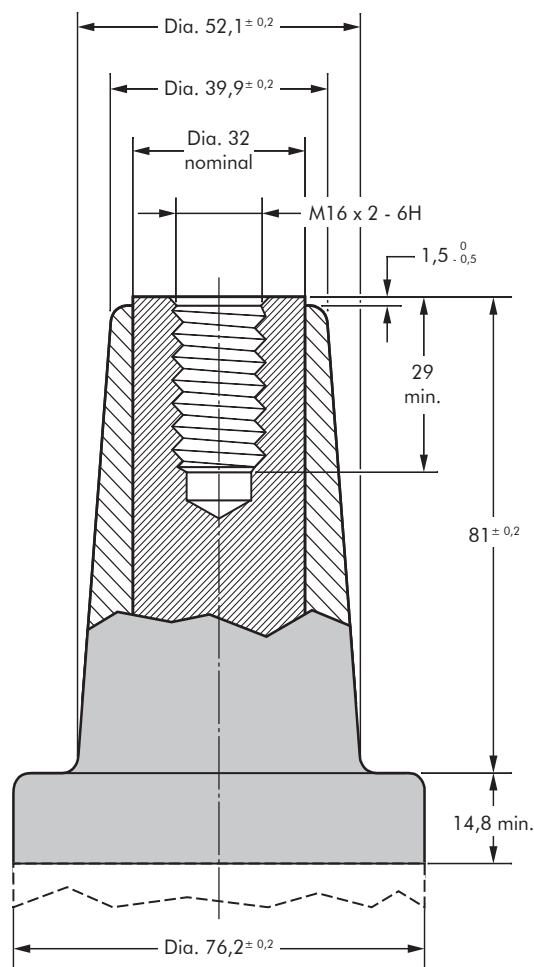

Connecting possibilities

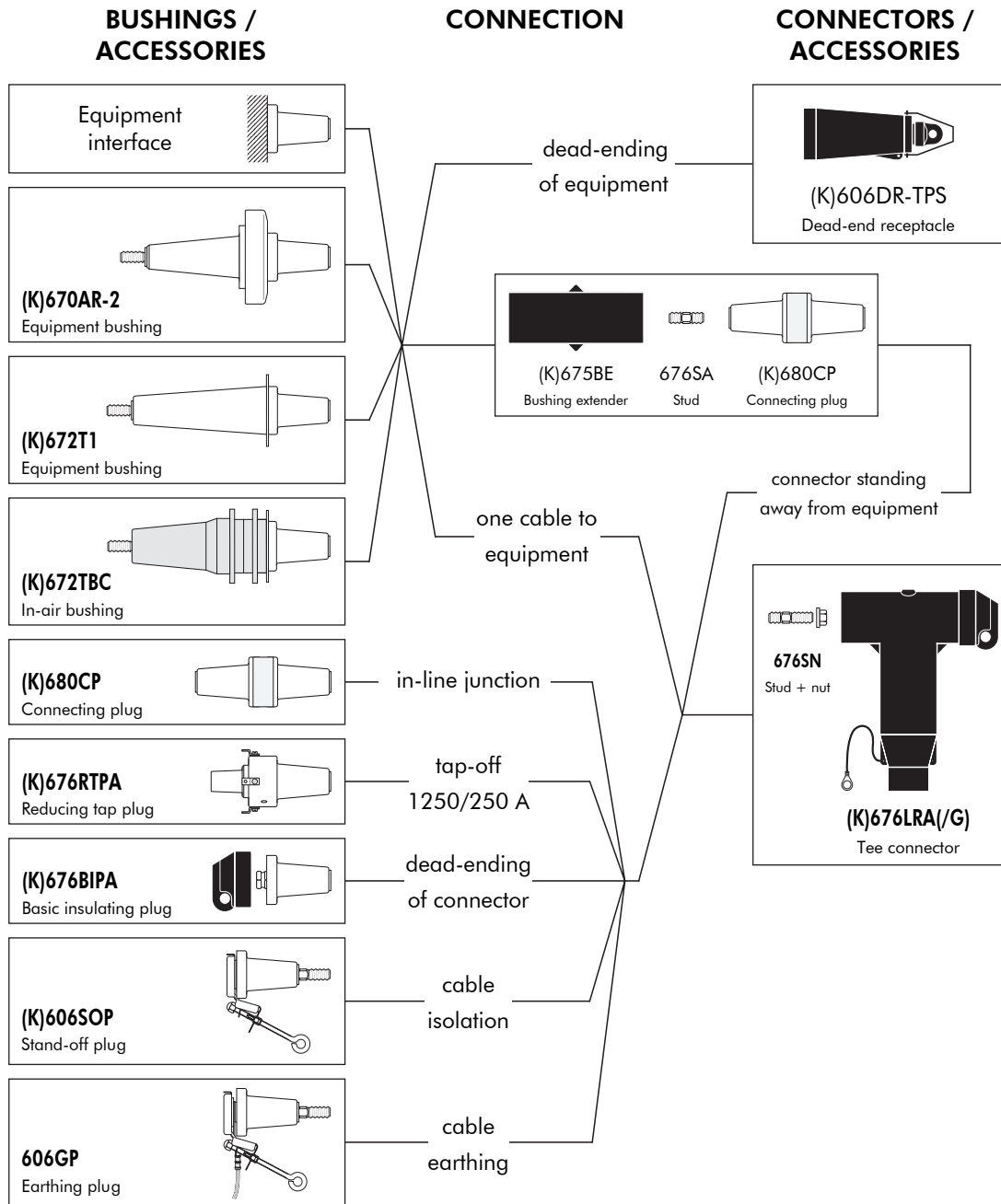

676LRA INTERFACE D TEE CONNECTOR

Up to 24 kV - 1250 A

Application

Separable tee connector designed to connect polymeric insulated cable to equipment (transformers, switch gear, motors...).

Also connects cable to cable, using the appropriate mating part.

Technical characteristics

- A thick conductive EPDM jacket provides a total safe to touch screen.
- Each separable connector is tested for AC withstand and partial discharge prior to leaving the factory.

6/10 (12) kV
6.35/11 (12) kV
8.7/15 (17.5) kV
12/20 (24) kV
12.7/22 (24) kV

Design

Separable connector comprising:

1. Conductive EPDM insert.
2. Conductive EPDM jacket.
3. Insulating EPDM layer moulded between the insert and the jacket.
4. Type D - 1250 A interface as described by CENELEC EN 50180 and 50181.
5. Conductor connector.
6. Basic insulating plug (with VD point).
7. Cable reducer.
8. Conductive rubber cap.
9. Threaded stud.
10. Earthing lead.

The screen break design enables cable outer sheath testing without removing or dismantling the connector.

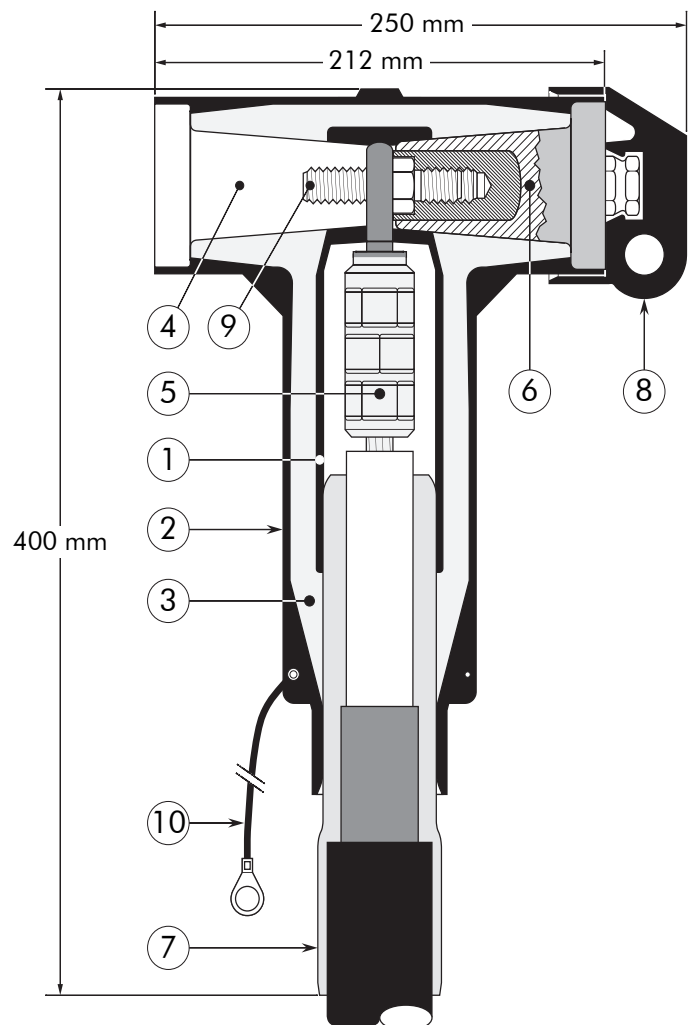

Specifications and standards

The separable connector 676LRA meets the requirements of CENELEC HD 629.1.

Separable connector type	Voltage U_m (kV)	Current I_r (A)	Conductor sizes (mm ²)	
			min.	max.
676LRA/G	12	1250	50	630
K676LRA/G	24	1250	35	630

Kit contents

The complete (K)676LRA tee connector kit comprises the following components:

The kit also comprises lubricant, wipers, installation instructions and crimp chart.

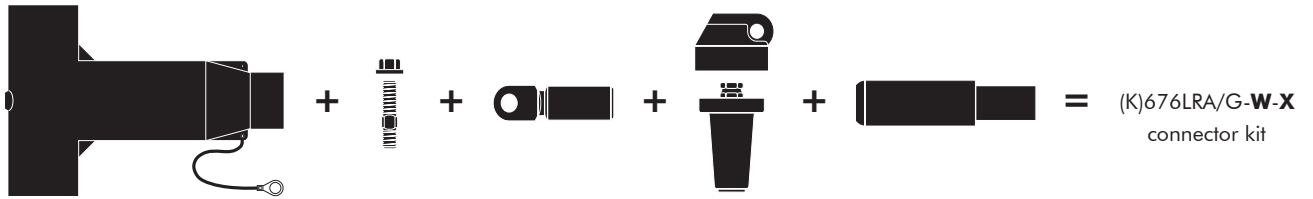

Connector housing
(K)650BLR/G

Threaded
stud + nut
676SN

Conductor
contact
TBC-X

Basic insulating
plug +
rubber cap
(K)676BIPA

Cable reducer
611CA-W

= (K)676LRA/G-W-X
connector kit

Ordering instructions

Select the part number which gives the best centring to the cable core insulation diameter.

Add a 'K' for use up to 24 kV.

Table W

Ordering part number	Dia. over core insulation (mm)	
	min.	max.
676LRA/G-15-X	16.0	22.0
676LRA/G-19-X	20.0	26.5
676LRA/G-22-X	23.5	31.0
676LRA/G-27-X	28.5	37.5
676LRA/G-32-X	34.0	42.5
676LRA/G-37-X	39.0	48.5
676LRA/G-43-X	45.5	56.0

Table X

Conductor sizes (mm ²)	Aluminium conductor		Copper conductor
	DIN hexagonal	Deep indent	DIN hexagonal
35	35(K)M-12-2	35KM-12-1	35(K)M-11-2
50	50(K)M-12-2	50(K)M-12-1	50(K)M-11-2
70	70(K)M-12-2	70(K)M-12-1	70(K)M-11-2
95	95(K)M-12-2	95(K)M-12-1	95(K)M-11-2
120	120(K)M-12-2	120(K)M-12-1	120(K)M-11-2
150	150(K)M-12-2	150(K)M-12-1	150(K)M-11-2
185	185(K)M-12-2	185(K)M-12-1	185(K)M-11-2
240	240(K)M-12-2	240(K)M-12-1	240(K)M-11-2
300	300(K)M-12-2	300(K)M-12-1	300(K)M-11-2
400	400(K)M-12-2	400(K)M-12-1	400(K)M-11-2
500	500(K)M-12-2	500(K)M-12-1	500(K)M-11-2
630	-	630(K)M-12-1	630(K)M-11-2

Example:

The copper wire screened cable is 24 kV, 630 mm² stranded aluminium with a diameter over core insulation of 44.0 mm.

Order a K676LRA/G-37-630KM-12-1 tee connector kit.

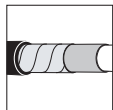

For use with copper tape screened cables.
Order: Kit MT.

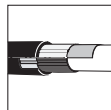

For use with Alupe or C 33-226 cables.
Please contact our representative.



For use in potentially explosive atmospheres (for 12 kV max.).
Order: -/ATEX.



For use with other cable types.
Please contact our representative.



For outdoor applications.
Order: +MWS.



Components can be ordered individually.

670AR-2 INTERFACE D EQUIPMENT BUSHING

Up to 24 kV - 1250 A

Application

For use in equipment insulated with oil fluid, typically for transformers, switch gear, capacitors...

Technical characteristics

Each bushing is tested for AC withstand and partial discharge prior to leaving the factory.

6/10 (12) kV
6.35/11 (12) kV
8.7/15 (17.5) kV
12/20 (24) kV
12.7/22 (24) kV

Design

The equipment bushing is a moulded epoxy insulated part in accordance with CENELEC EN 50180.

Specifications and standards

The bolted type equipment bushings 670AR-2 meet the requirements of IEC 137.

Ordering instructions

To order the equipment bushing, specify the type. The bushing are supplied with an earth lead (/J) or a earth plate (/GS). This earth connection must be specified when ordering.

E.g. K670AR-2/GS.

For use in potentially explosive atmospheres (for 12 kV max.).

Order: -/ATEX.

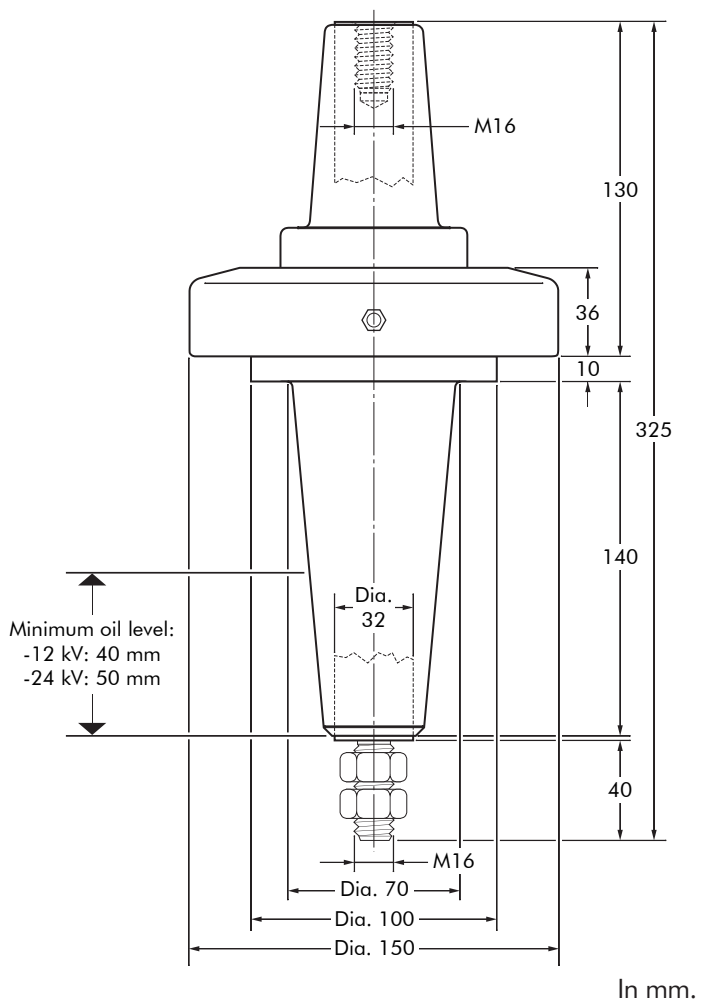

Equipment bushing type	Voltage U_r (kV)	Current I_r (A)
670AR-2	12	1250
K670AR-2	24	1250

672T1 INTERFACE D EQUIPMENT BUSHING

Up to 24 kV - 1250 A

Application

For use in equipment insulated with oil fluid, typically for transformers, switch gear, capacitors...

Technical characteristics

Each bushing is tested for AC withstand and partial discharge prior to leaving the factory.

6/10 (12) kV
6.35/11 (12) kV
8.7/15 (17.5) kV
12/20 (24) kV
12.7/22 (24) kV

Design

The equipment bushing is a moulded epoxy insulated part in accordance with CENELEC EN 50180.

Specifications and standards

The bolted type equipment bushings 672T1 meet the requirements of IEC 137.

Ordering instructions

To order the equipment bushing, specify the type.
For use in potentially explosive atmospheres (for 12 kV max.).
Order: -/ATEX.

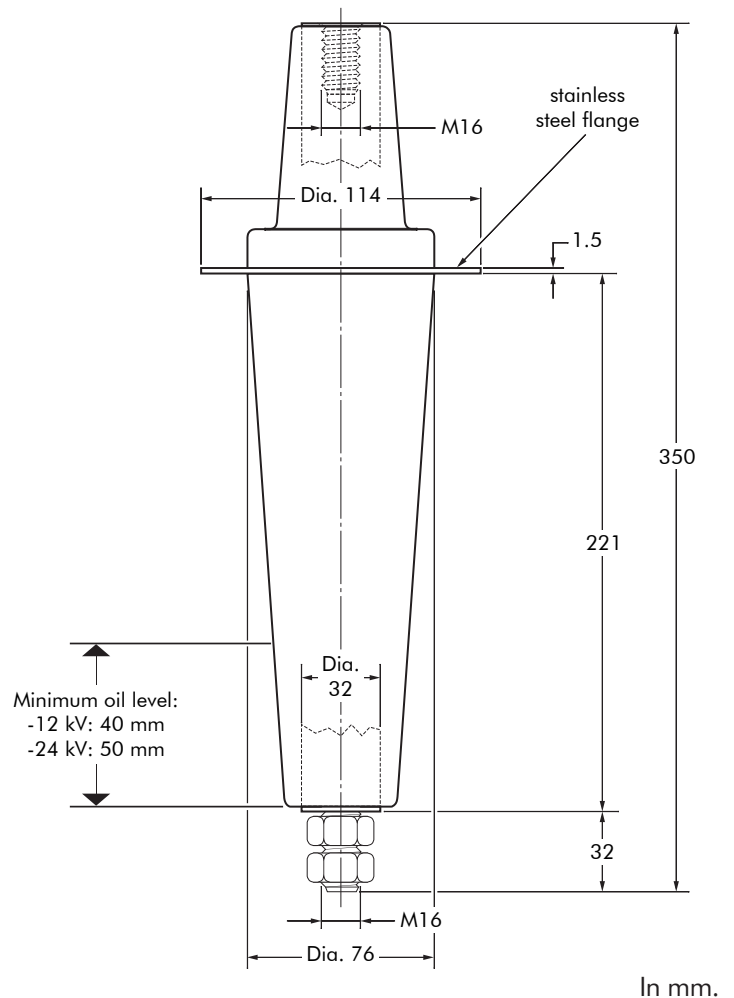

Equipment bushing type	Voltage U_r (kV)	Current I_r (A)
672T1	12	1250
K672T1	24	1250

672TBC INTERFACE D EQUIPMENT BUSHING

Up to 24 kV - 1250 A

Application

For use in equipment insulated with air, typically for transformers, switch gear, capacitors...

Technical characteristics

Each bushing is tested for AC withstand and partial discharge prior to leaving the factory.

6/10 (12) kV
6.35/11 (12) kV
8.7/15 (17.5) kV
12/20 (24) kV
12.7/22 (24) kV

Design

The equipment bushing is a moulded epoxy insulated part in accordance with CENELEC EN 50181.

Non-tracking insulating rubber boot and collars slip over the bushing shank.

Specifications and standards

The bolted type equipment bushings 672TBC meet the requirements of IEC 137.

Ordering instructions

To order the equipment bushing, specify the type.
For use in potentially explosive atmospheres (for 12 kV max.).
Order: -/ATEX.

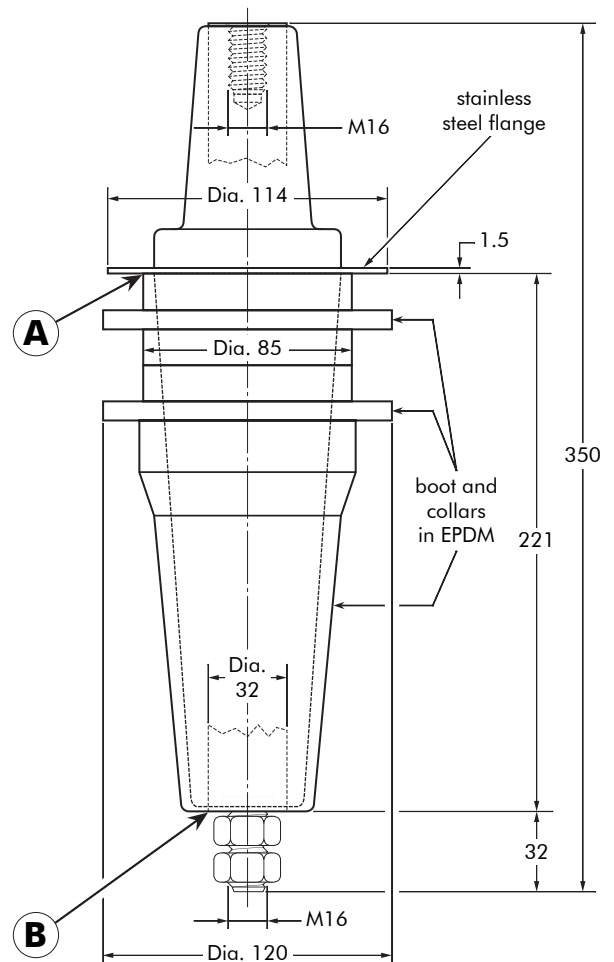

In mm.

Equipment bushing type	Voltage U_r (kV)	Current I_r (A)	Creepage distance A-B (mm)
672TBC	12	1250	300
K672TBC	24	1250	300

FIXINGS FOR EQUIPMENT BUSHINGS INTERFACE D

670AR-2/GS bushing

NFC 52-053

French standards.

670AR-2/J bushing

NFC 52-053

French standards.

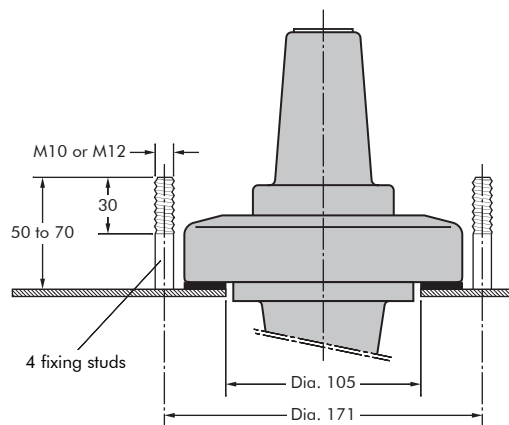
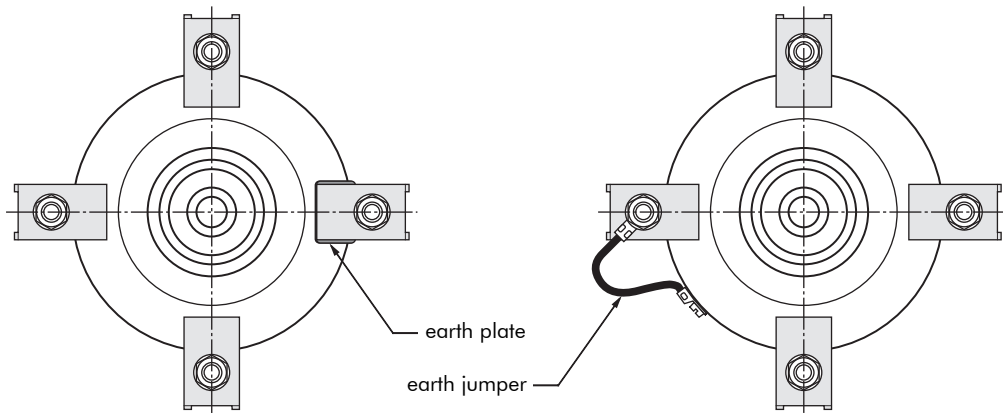
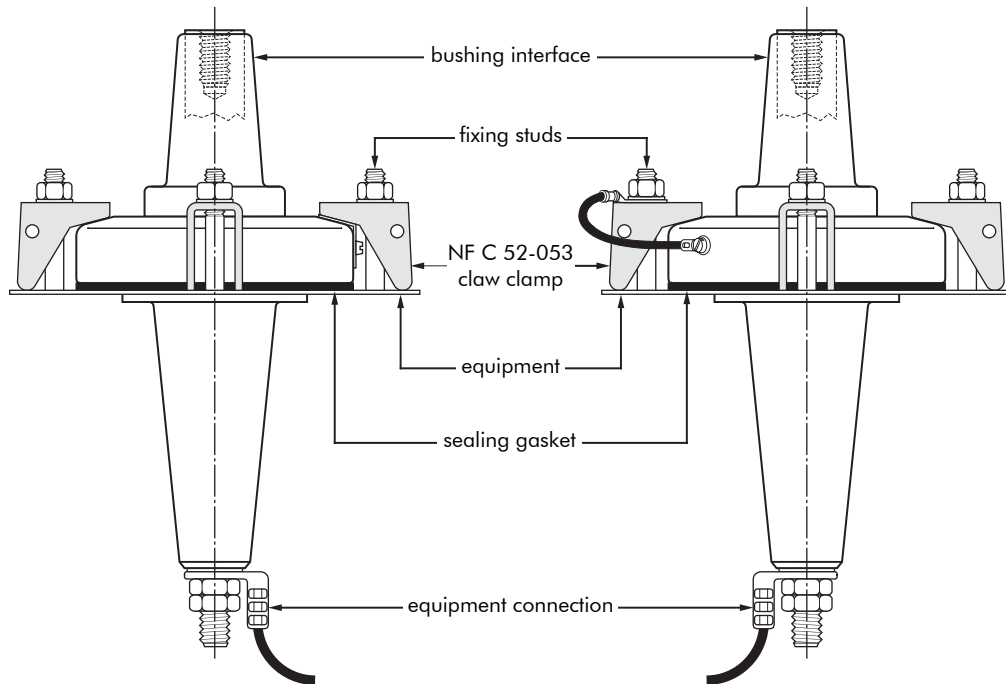

672T1 bushing

672TBC bushing

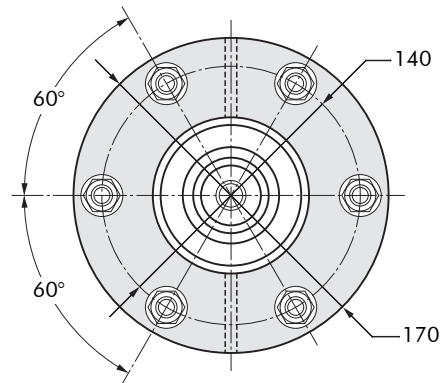
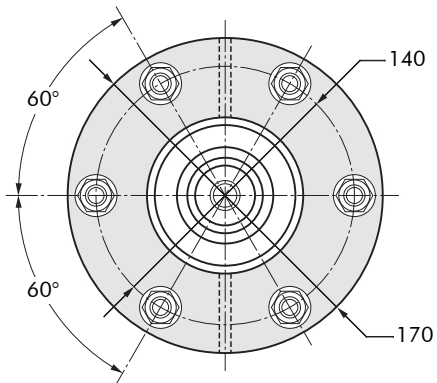
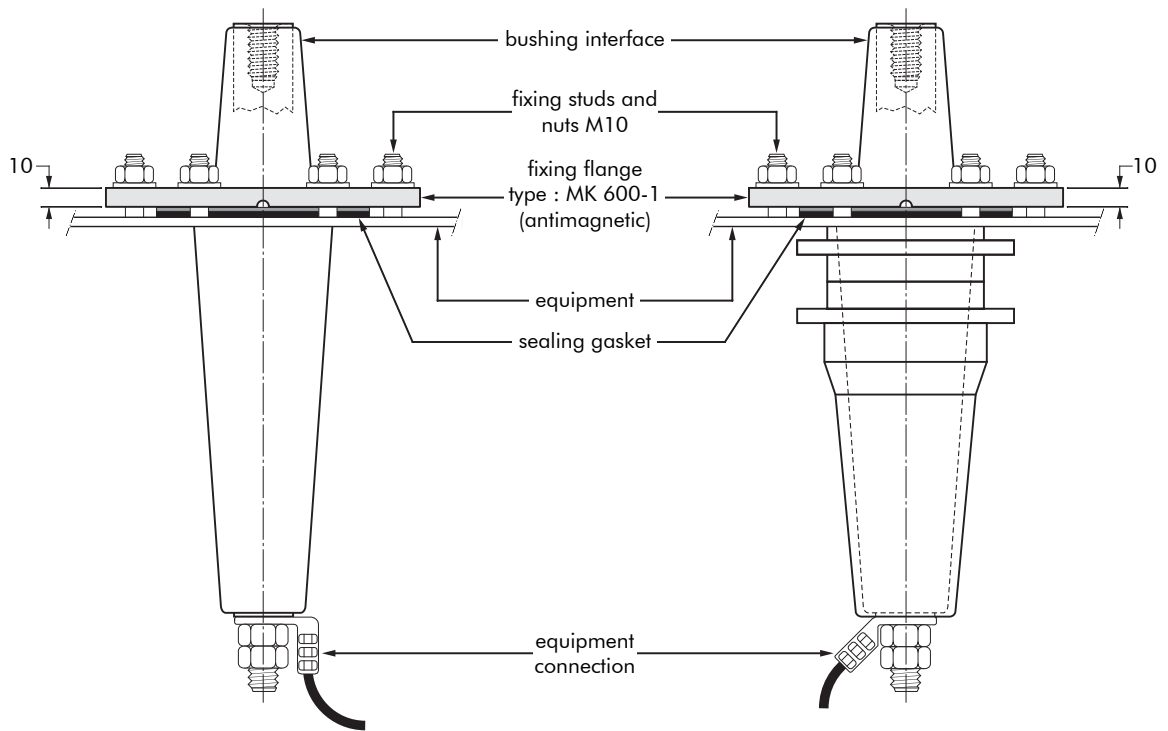

In mm.

ACCESSORIES INTERFACE D

Application

For use with connectors and bushings with an interface D as described by CENELEC EN 50180 and 50181.

Technical characteristics

All these products, except the earthing plug, are tested for AC withstand and partial discharge prior to leaving the factory.

Up to 24 kV

6/10 (12) kV
6.35/11 (12) kV
8.7/15 (17.5) kV
12/20 (24) kV
12.7/22 (24) kV

606DR-TPS Dead-end receptacle

Fits over a bushing with a type D interface to provide 'dead-end' facility.

Contains a capacitive test point for checking circuit conditions.

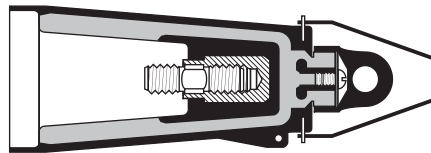

Ordering instructions

Order

606DR-TPS for 12 kV or
K606DR-TPS for 24 kV
applications.

The dead-end receptacle can
be supplied with an earth lead.

Order: -/G.

E.g. 606DR-TPS/G.

606SOP Stand-off plug

Is designed to support and 'dead-end' connectors with a type D interface when removed from equipment.

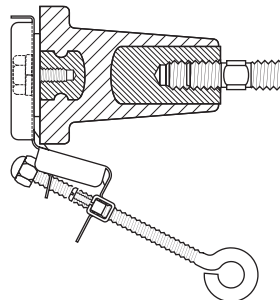

Ordering instructions

Order

606SOP for 12 kV or
K606SOP for 24 kV
applications.

606GP Earthing plug

Is designed to support and earth connectors with a type D interface when removed from equipment.

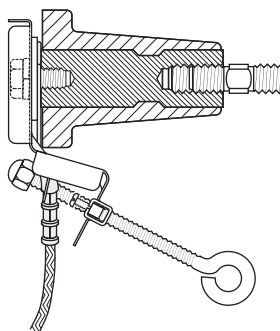

Ordering instructions

Order

606GP for 12 or 24 kV
applications.

675BE Bushing extender

Provides an extension piece to allow cables to stand away from equipment.
Is used in conjunction with the 680CP connecting plug.

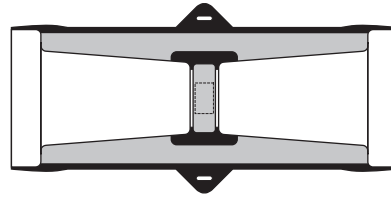

Ordering instructions

Order
675BE for 12 kV or
K675BE for 24 kV
applications.

676BIPA Basic insulating plug

Acts as a tightening nut for the 676LRA/G tee connector kits.
The plug contains a voltage detection point.
The conductive rubber protection cap is included.

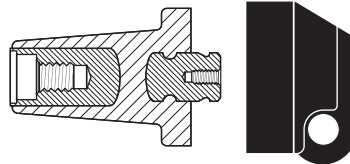

Ordering instructions

Order
676BIPA for 12 kV or
K676BIPA for 24 kV
applications.

680CP Connecting plug

For connecting two or more connectors with a type D interface together, thus creating a separable cable joint or a multiple cable connection to equipment.

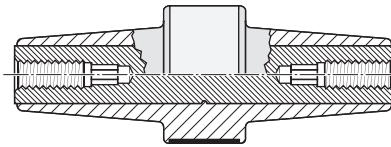

Ordering instructions

Order
680CP for 12 kV or
K680CP for 24 kV
applications.
Order: -/ATEX for use in
potentially explosive
atmospheres (for 12 kV max.).

676RTPA Reducing tap plug

Provides a type A interface to connectors with a type D interface.
A 'C' spanner, 600SW, is used to tighten the reducing tap plug on to its mating part.

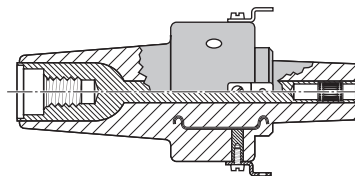

Ordering instructions

Order
676RTPA for 12 kV or
K676RTPA for 24 kV
applications.
Order 600SW for the 'C'
spanner.

Kit MT Earthing kit for copper tape screened cables

Contains a tinned copper braid (25 mm² - L = 500 mm), a tinned copper wire for cleaning and water sealing mastic.

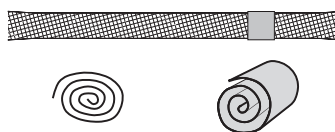

Ordering instructions

Order
Kit MT for 12 kV or 24 kV
applications.

POSSIBLE ARRANGEMENTS INTERFACE D

676LRA/G

Single cable arrangement.
Order 676LRA/G for 12 kV or
K676LRA/G for 24 kV
applications.

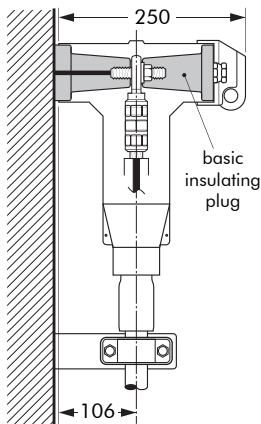

676LRA/G-P2

Dual cable arrangement.
Order 676LRA/G-P2 for 12 kV
or K676LRA/G-P2 for 24 kV
applications.

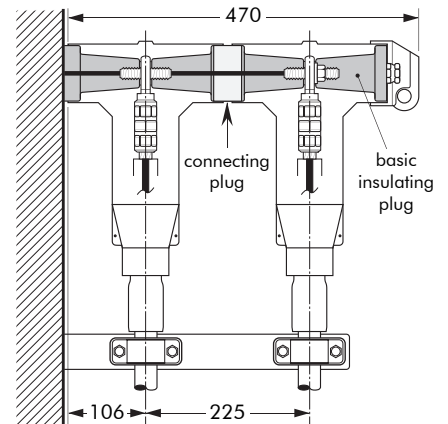

676LRA/G-P3

Triple cable arrangement.
Order 676LRA/G-P3 for 12 kV
or K676LRA/G-P3 for 24 kV
applications.

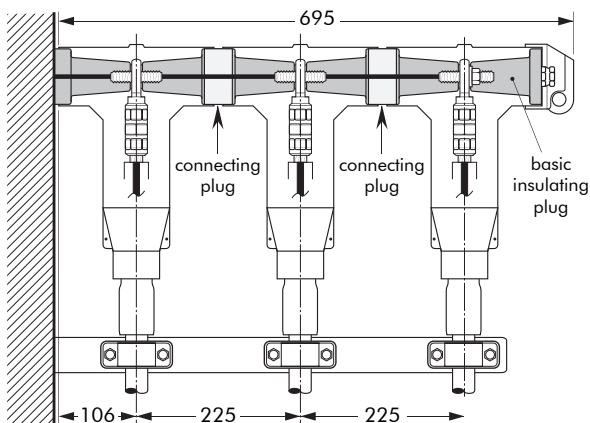

676LRA/G-P4

Single cable arrangement with
tap-off.
Order 676LRA/G-P4 for 12 kV
or K676LRA/G-P4 for 24 kV
applications.

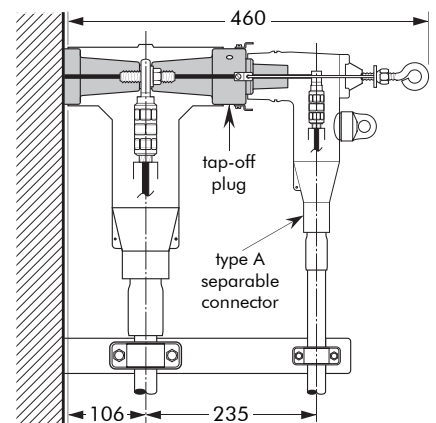

676LRA/G-P5

Dual cable arrangement with tap-off.
Order 676LRA/G-P5 for 12 kV
or K676LRA/G-P5 for 24 kV
applications.

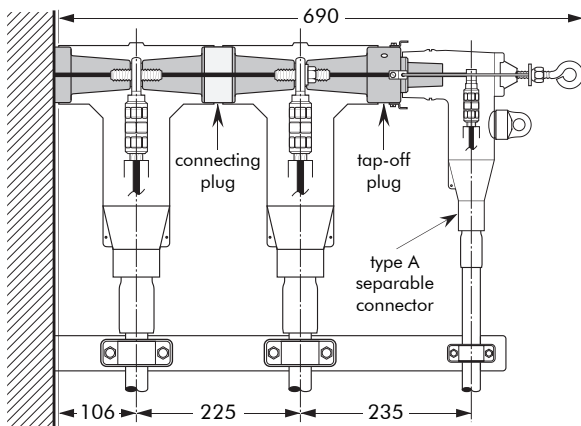

676LRA/G-P6

Connector standing away from equipment.
Order 676LRA/G-P6 for 12 kV
or K676LRA/G-P6 for 24 kV
applications.

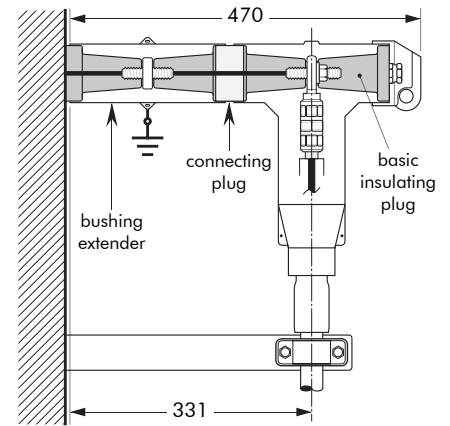

676LRA/G-L1

Dead-ending.
Order 676LRA/G-L1 for 12 kV
or K676LRA/G-L1 for 24 kV
applications.

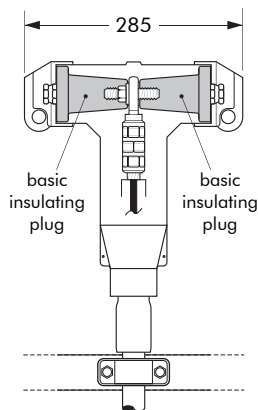

676LRA/G-L3

3-way connection.
Order 676LRA/G-L3 for 12 kV
or K676LRA/G-L3 for 24 kV
applications.

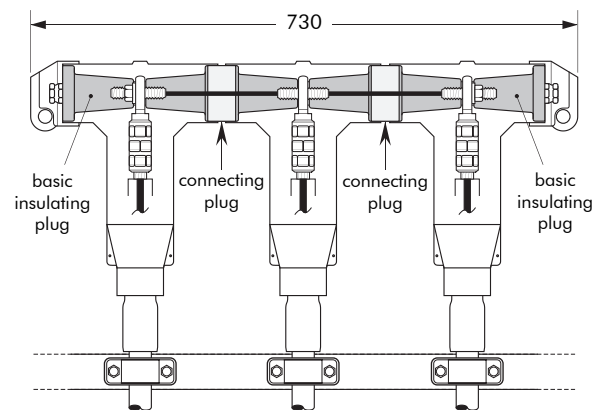

676LRA/G-L2

2-way connection.
Order 676LRA/G-L2 for 12 kV
or K676LRA/G-L2 for 24 kV
applications.

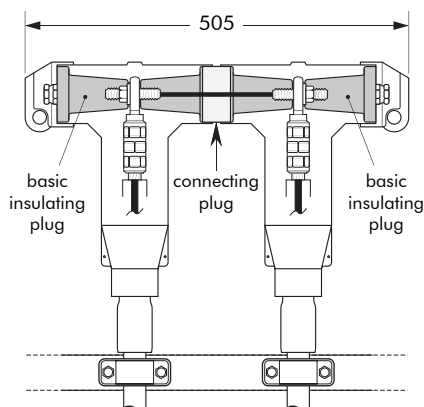

676LRA/G-L4

4-way connection.
Order 676LRA/G-L4 for 12 kV
or K676LRA/G-L4 for 24 kV
applications.

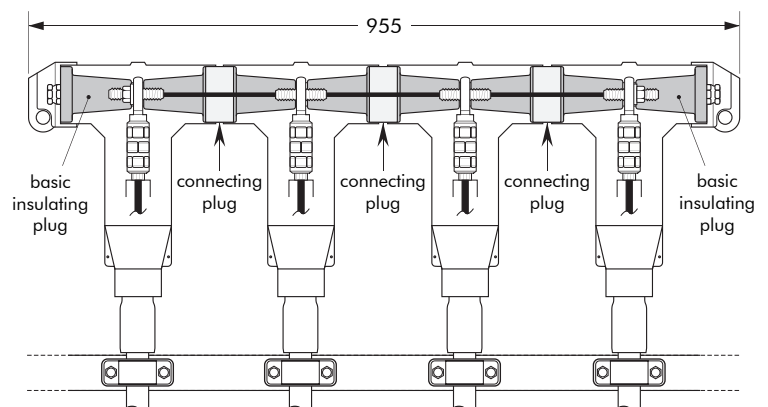

676LRA/G-L5

2-way connection with tap-off.
Order 676LRA/G-L5 for 12 kV
or K676LRA/G-L5 for 24 kV
applications.

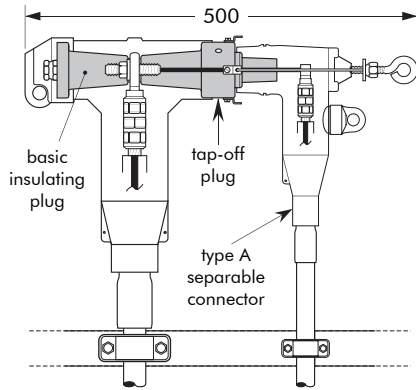

676LRA/G-L6

3-way connection with two
tap-offs.
Order 676LRA/G-L6 for 12 kV
or K676LRA/G-L6 for 24 kV
applications.

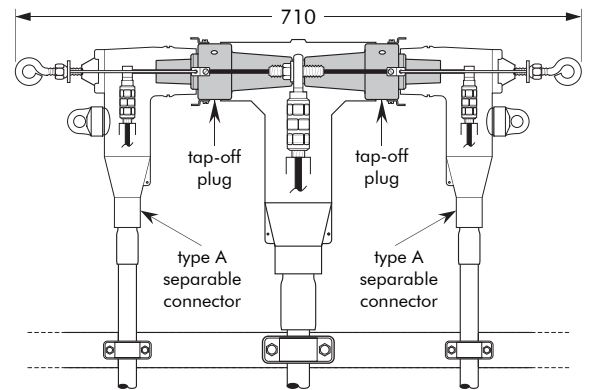

676LRA/G-L7

3-way connection with one
tap-off.
Order 676LRA/G-L7 for 12 kV
or K676LRA/G-L7 for 24 kV
applications.

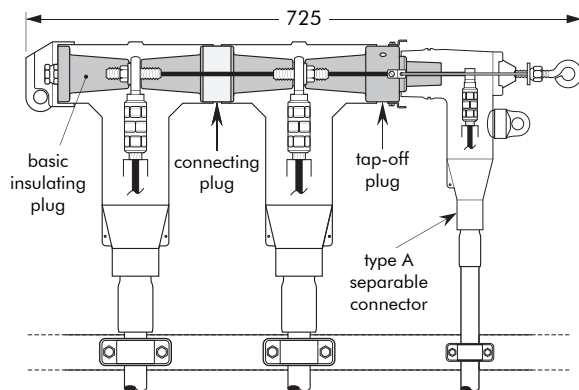

676LRA/G-L8

4-way connection with two
tap-offs.
Order 676LRA/G-L8 for 12 kV
or K676LRA/G-L8 for 24 kV
applications.

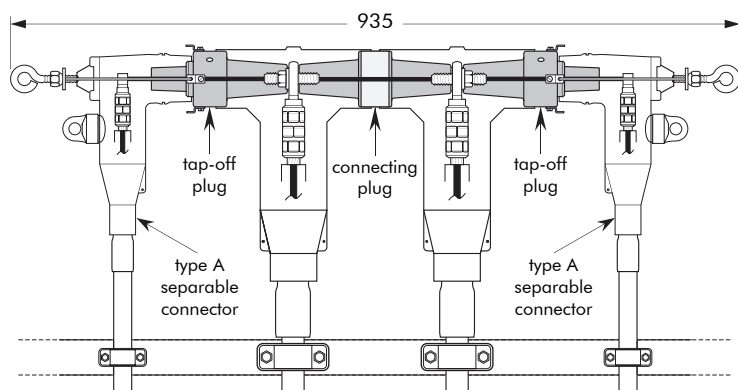

676LRA/G-L9

4-way connection with one tap-off.

Order 676LRA/G-L9 for 12 kV
or K676LRA/G-L9 for 24 kV
applications.

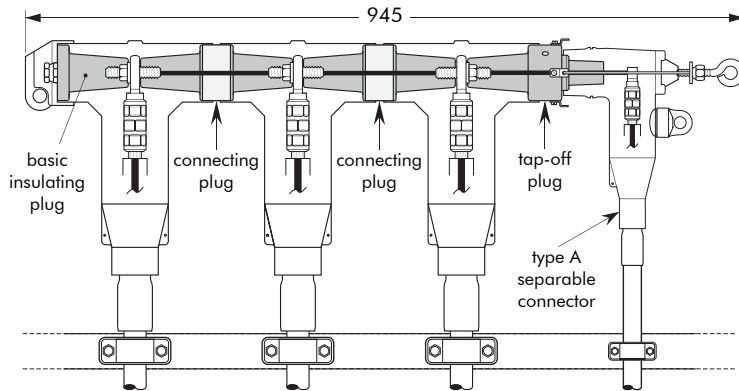

Connector on stand-off plug

Order 606SOP for 12 kV or
K606SOP for 24 kV
applications.

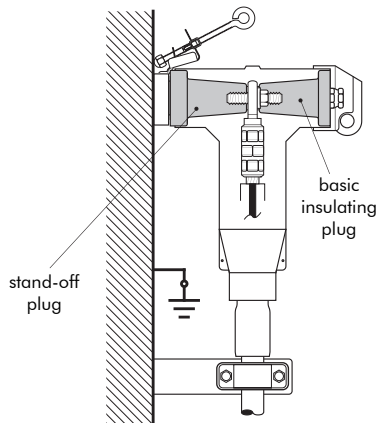

Connector on earthing plug

Order 606GP for 12 kV and
24 kV applications.

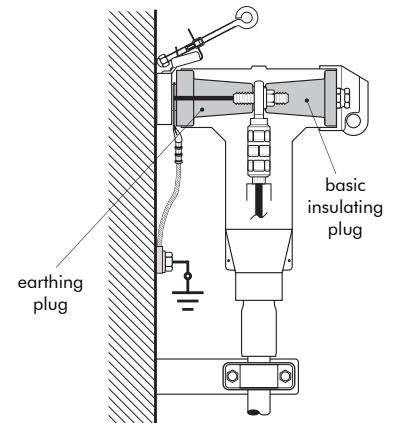



WWW.CABLEJOINTS.CO.UK
THORNE & DERRICK UK
TEL 0044 191 490 1547 FAX 0044 477 5371
TEL 0044 117 977 4647 FAX 0044 977 5582
WWW.THORNEANDDERRICK.CO.UK

Euromold
a Nexans company