



ELASTIMOLD System Planning Guide



CABLE JOINTS, CABLE TERMINATIONS, CABLE GLANDS, CABLE CLEATS
FEEDER PILLARS, FUSE LINKS, ARC FLASH, CABLE ROLLERS, CUT-OUTS

11KV 33KV CABLE JOINTS & CABLE TERMINATIONS
FURSE EARTHING

www.cablejoints.co.uk
Thorne and Derrick UK
Tel 0044 191 490 1547 Fax 0044 191 477 5371
Tel 0044 117 977 4647 Fax 0044 117 977 5582



INTRODUCTION

Catalog 2001 provides an easy-to-use, comprehensive listing of ELASTIMOLD products for 5kV thru 35kV underground power distribution systems. Included are separable elbow connectors, cable joints, splices, terminations, surge arresters, fused elbows and other cable accessory components. The catalog incorporates information relative to product application, ratings and selection.

ELASTIMOLD is recognized as the leading producer of premolded cable accessory components worldwide. Utilizing specially formulated materials with 100% peroxide-cured insulation and shielding, Elastimold products represent the state-of-the-art in premolded process technology. Durable, quality construction and non-degrading, high-reliability, maintenance-free performance is assured when specifying ELASTIMOLD products.

ELASTIMOLD's broad line of premolded products offer significant advantages over field-fabricated and other alternatives, including: 100% factory assurance testing prior to delivery and installation; simplified, single-piece construction with built-in insulating, shielding and sealing surfaces; ease of installation with no special skills or tools required; and compact, lightweight, durable designs for easy handling and application.

Separable Elbow Connectors and their related accessories are available in 200 Amp loadbreak, 200 Amp deadbreak and 600 Amp deadbreak styles. Rated for padmount, subsurface, vault, indoor, outdoor and other applications, units feature interchangeable interfaces which can be easily engaged or separated to provide a convenient method to connect or disconnect cable and equipment to the distribution system.

Cable Joints and Splices are available in permanently crimped or bolted (separable) connector styles. Units are rated the same as the cable they are connecting and are available for all applications including direct buried.

Cable Terminations are available in single-piece or modular designs. Rated for indoor, outdoor or padmount applications, units allow connection and transition from shielded underground cables to bare overhead conductors and live-front equipment.

Surge Arresters are constructed using metal oxide blocks for overvoltage protection and 200 Amp separable connector interfaces for attachment to other ELASTIMOLD accessories.

Fused Elbows combine replaceable current-limiting fuses for overcurrent protection and 200 Amp separable connector interfaces for attachment to other ELASTIMOLD accessories.

Loadbreak Switches, Molded Current Limiting Fuses, Molded Power Fuses and Transmission Class Products are shown on the back cover. For additional catalog information on these product lines, please contact your ELASTIMOLD Sales Representative.

Elastimold Special Component Services Group provides custom products tailored to specific application requirements. Please contact the factory for further information regarding this service.

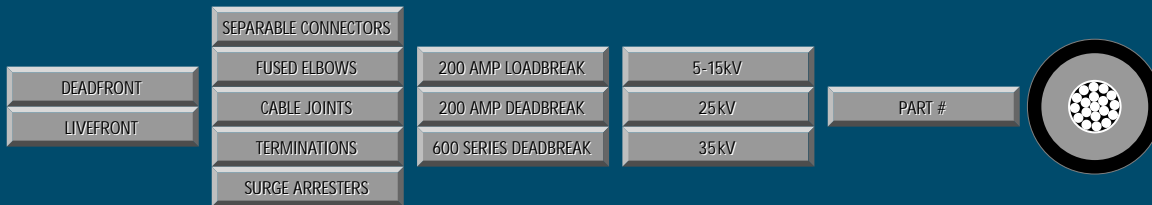

Part numbers that contain the letters **W** or **X** are size sensitive. To complete the part number, refer to the **W** or **X** tables indicated.

COMPONENT APPLICATION AND SELECTION

Catalog 2001 includes component group schematics, part numbers and standard ratings of ELASTIMOLD products for application on underground power distribution systems utilizing solid dielectric cable. Go directly to the product section in the table of contents or follow the decision path outlined below for component selection and application.

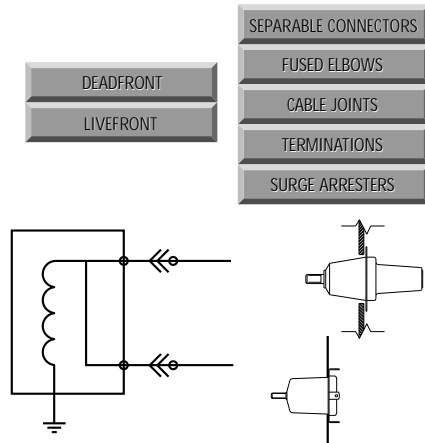

- Determine if the application involves **Deadfront** (shielded) or **Livefront** (unshielded) connections. Terminations are air insulated and classified as Livefront.

- Determine if the application requires **Separable Connectors, Fused Elbows, Cable Joints, Terminations** or **Surge Arresters**.

- If Separable Connectors are involved, determine the required current class: **200 Amp** or **600 Amp** and above. This decision is based on the conductor size, loading, and system short circuit currents. The selected connector must be compatible with the mating interface on any equipment.



- 200 Amp connectors are available in **Loadbreak** and **Deadbreak** styles. Determine which style is required. 600 Series Connectors are Deadbreak only and Fused Elbows are Loadbreak only.

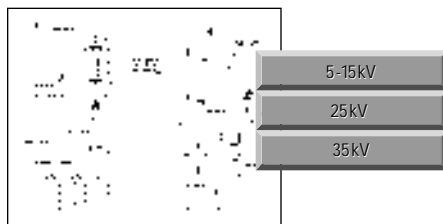

- Determine the part number related to the specific **Voltage Class** by utilizing the schematic layouts and product tables.



- If the component mates with cable, determine the cable insulation diameter, conductor size, type of cable shield and if jacket sealing is required.

TABLE OF CONTENTS

• Certified Tests and Performance	2	• Cable Terminations	22-25
• Separable Connector Interfaces	3	• Surge Arresters.....	26, 27
• 200 Amp Loadbreak Connectors.....	4-7	• Shield Adapters, Grounding Kits & Jacket Seals	28, 29
• 200 Amp Deadbreak Connectors	8, 9	• How to specify size-sensitive products	30, 31
• 600 Series Deadbreak Connectors	10-13	• WX Size Tables.....	32, 33
• 600 Series Deadbreak Connectors		• AEIC Cable Insulation Diameter Reference	34
– Cam-Op, Link-Op	14,15	• Cable Conductor Diameter Reference.....	35
• 600 Series Deadbreak Connectors		• Equipment Bushings	36
– Stick-Op, Window-Op	16,17	• Loadbreak Switches, Molded Current	
• 600 Series Deadbreak Cable Joints.....	18,19	Limiting Fuses, Molded Power Fuses	
• PCJ Cable Joints	20,21	and Transmission Class products.....	Back Cover



CERTIFIED TESTS AND PERFORMANCE

Elastimold Separable Connectors, Cable Joints, Cable Terminators, Surge Arresters, Fused Elbows and other cable accessory products have been designed and tested per applicable portions of IEEE, ANSI, NEMA and other industry standards including:

- IEEE 386 Standard For Separable Connectors
- IEEE 404 Standard For Cable Joints and Splices
- IEEE 48 Standard For Cable Terminations

- IEEE C62.11 Standard For Metal Oxide Surge Arresters
- ANSI C37.41 Standard For Current Limiting Fuses
- IEEE 592 Standard For Exposed Semiconducting Shields
- ANSI C119.4 Standard For Copper and Aluminum Conductor Connectors
- AEIC CS5 and CS6 Standards For XLP and EPR Insulated Cables

CABLE JOINTS, TERMINATIONS AND ARRESTER RATINGS

Refer to the pages listed below for rating information:

- PCJ Cable Joints, page 20.
- Cable Terminations, page 22
- Surge Arresters, page 26.

SEPARABLE CONNECTOR RATINGS

Table 1 shows voltage and current ratings which apply to all Separable Connectors including 200 AMP Loadbreak, 200 AMP Deadbreak and 600 Series Deadbreak products. Table 2 shows switching and fault close ratings which only apply to 200 AMP Loadbreak Connectors.

TABLE 1	15kV Class Ratings	25kV Class Ratings	35kV Class Ratings
<ul style="list-style-type: none"> • OPERATING VOLTAGE Maximum line-to-ground (See Application Info Note 1) 	8.3kV	15.2kV	21.1kV
<ul style="list-style-type: none"> • BIL Impulse withstand 1.2 x 50 microsecond wave 	95kV	125kV	150kV
<ul style="list-style-type: none"> • WITHSTAND VOLTAGE AC One Minute DC Fifteen Minute 	34kV 53kV	40kV 78kV	50kV 103kV
<ul style="list-style-type: none"> • CORONA EXTINGUISHMENT LEVEL @ 3pC Sensitivity 	11kV	19kV	26kV
200 AMP Products Continuous Current: Symmetrical Momentary Current: 600 Series Products Continuous Current: Symmetrical Momentary Current:	200 AMP* 10kA sym, 10 cycle duration 600 and 900 AMP* 25kA sym, 10 cycle duration * Designed for 90° C maximum continuous operating temperature		

TABLE 2	LOADMAKE/LOADBREAK SWITCHING	FAULT CLOSE
15kV Class Ratings	<ul style="list-style-type: none"> • 1ϕ and 3ϕ circuits 8.3kV line to ground, 14.4kV max. across open contacts. • 10 loadmake/break operations at 200 Amps max. with 70 to 80% lagging power factor. 	1 fault close operation at 8.3kV or 14.4kV; 10,000 Amps, rms, sym. 10 cycles (0.17 sec.) 1.3 max. asym factor applies to new or used mating parts (up to maximum designated switching operations.)
25kV Class Ratings	<ul style="list-style-type: none"> • 1ϕ and 3ϕ circuits 15.2kV line to ground, 26.3kV max. across open contacts. • 10 loadmake/break operations at 200 Amps max. with 70 to 80% lagging power factor. 	1 fault close operation at 15.2kV or 26.3kV; 10,000 Amps, rms, sym. 10 cycles (0.17 sec.) 1.3 max. asym factor applies to new or used mating parts (up to maximum designated switching operations.)
35kV Class Ratings	<ul style="list-style-type: none"> • 1ϕ and 3ϕ circuits 21.1kV line to ground, 36.6kV max. across open contacts. • 10 loadmake/break operations at 200 Amps max. with 70 to 80% lagging power factor. 	1 fault close operation at 21.1kV or 36.6kV; 10,000 Amps, rms, sym. 10 cycles (0.17 sec.) 1.3 max. asym factor applies to new or used mating parts (up to maximum designated switching operations.)

Application Information:

1. Loadbreak connectors are designed and rated for use on grounded WYE systems. For application on ungrounded WYE or delta systems, the next higher voltage class product is recommended. Examples: 5kV ungrounded: use 15kV class products; 15kV ungrounded: use 25kV class products; 25kV ungrounded: use 35kV class products; 35kV ungrounded: contact factory.
2. Products are designed and constructed for all applications including padmount, subsurface, vault, indoor, outdoor, direct sunlight, direct buried and continuously submerged in water.
3. Products are designed and rated for ambient temperatures of -40° C to + 65° C. It is recommended that loadbreak connectors be hotstick operated at -20° C to + 65° C ambient temperature range and at altitudes not exceeding 6000 feet.





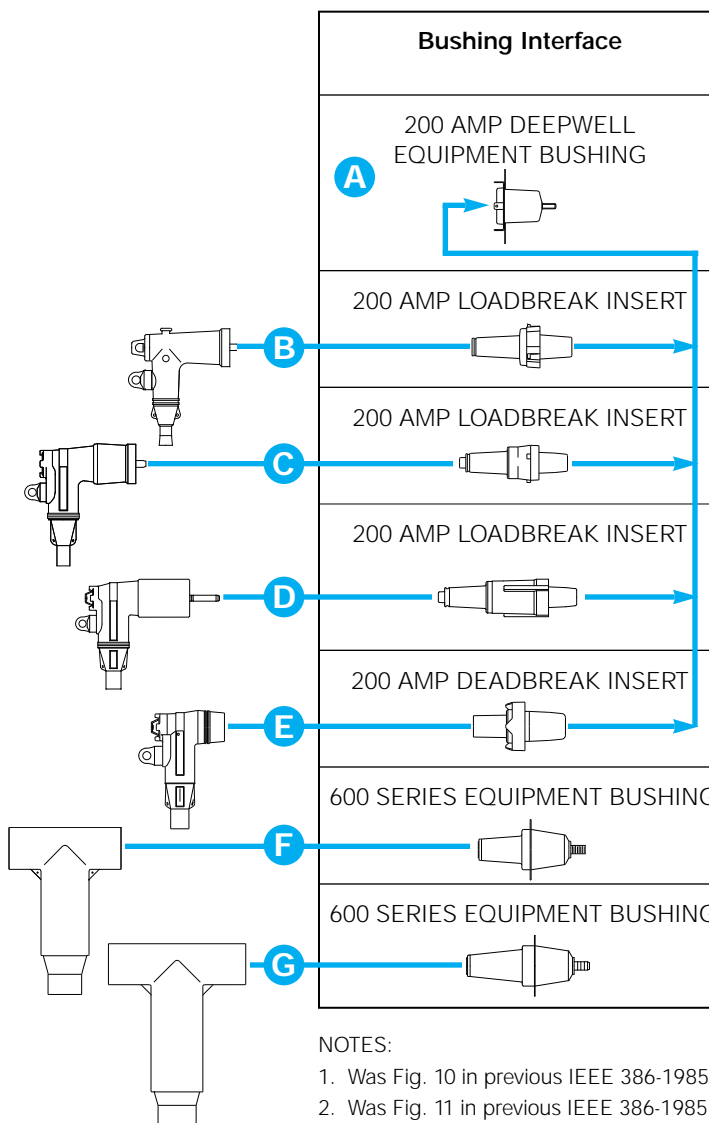

SEPARABLE CONNECTOR INTERFACES

STANDARD INTERFACES FOR SEPARABLE CONNECTORS, COMPONENTS AND EQUIPMENT BUSHINGS

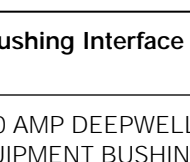
ANSI/IEEE Standard 386 defines the specific interface dimensions that 200 Amp and 600 Series elbows, inserts, junctions, equipment bushings and any mating components must conform to insure interchangeability. The table

below provides information concerning the types of interfaces supplied by Elastimold for various applications and is useful to assure proper matching of components.



Bushing Interface	Voltage Class	Interface Description	Standard No Figure No.
A 200 AMP DEEPWELL EQUIPMENT BUSHING 	15kV, 25kV and 35kV	200 AMP Bushing Well Interface 8.3kV, 15.2kV, 21.1kV	A IEEE 386-1995 Fig. 3
B 200 AMP LOADBREAK INSERT 	15kV	200 AMP Loadbreak 8.3kV and 8.3kV/14.4kV	B IEEE 386-1995 Fig. 5
C 200 AMP LOADBREAK INSERT 	25kV	200 AMP Loadbreak 15.2kV and 15.2kV/26.3kV	C IEEE 386-1995 Fig. 7, Note 3
D 200 AMP LOADBREAK INSERT 	35kV	200 AMP Loadbreak Interface No. 2 21.1kV and 21.1kV/36.6kV	D IEEE 386-1995 Fig. 7, Note 3
E 200 AMP DEADBREAK INSERT 	15kV and 25kV	200 AMP Deadbreak 8.3kV and 15.2kV	E IEEE 386-1985 Fig. 4
F 600 SERIES EQUIPMENT BUSHING 	15kV and 25kV	600 AMP Deadbreak Interface No.1 8.3kV and 15.2kV	F IEEE 386-1995 Fig.11, Note 1
G 600 SERIES EQUIPMENT BUSHING 	35kV	600 AMP Deadbreak Interface No.1 21.1kV	G IEEE 386-1995 Fig.13, Note 2

NOTES:
 1. Was Fig. 10 in previous IEEE 386-1985 publication.
 2. Was Fig. 11 in previous IEEE 386-1985 publication.
 3. Elastimold uses Fig. 7 interface for both 25 and 35kV applications.



SEPARABLE CONNECTORS 200 AMP LOADBREAK

200 Amp loadbreak connectors and accessories provide a convenient method to connect/disconnect cable and equipment on power distribution systems. Loadbreak elbows include provisions for energized operation using standard hotstick tools, allowing load-make/break operation and a visible disconnect. Components can be isolated with insulated caps, plugs and parking bushings.

Optional accessories allow system grounding, testing, bypass, lightning surge protection and current limiting fusing. Additional connecting points and taps can be provided by use of junctions or feed-thrus.

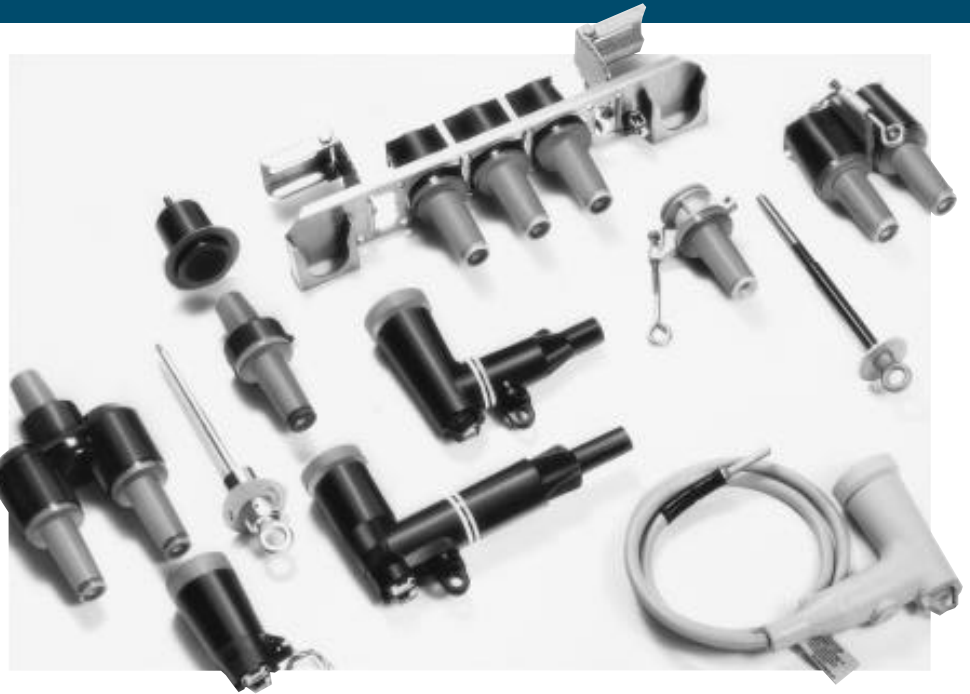

RATINGS OVERVIEW

See page 2 for complete information including switching and fault close ratings.

CURRENT RATINGS

200A Continuous
10kA sym. 10 Cycles

VOLTAGE RATINGS

15kV Class
8.3kV Phase-to-Ground
14.4kV Phase-to-Phase
95kV BIL
34kV AC Withstand
53kV DC Withstand
11kV Corona Extinction

25kV Class

15.2kV Phase-to-Ground
26.3kV Phase-to-Phase
125kV BIL
40kV AC Withstand
78kV DC Withstand
19kV Corona Extinction

35kV Class

21.1kV Phase-to-Ground
36.6kV Phase-to-Phase
150kV BIL
50kV AC Withstand
103kV DC Withstand
26kV Corona Extinction

200 AMP LOADBREAK SEPARABLE CONNECTOR COMPONENTS

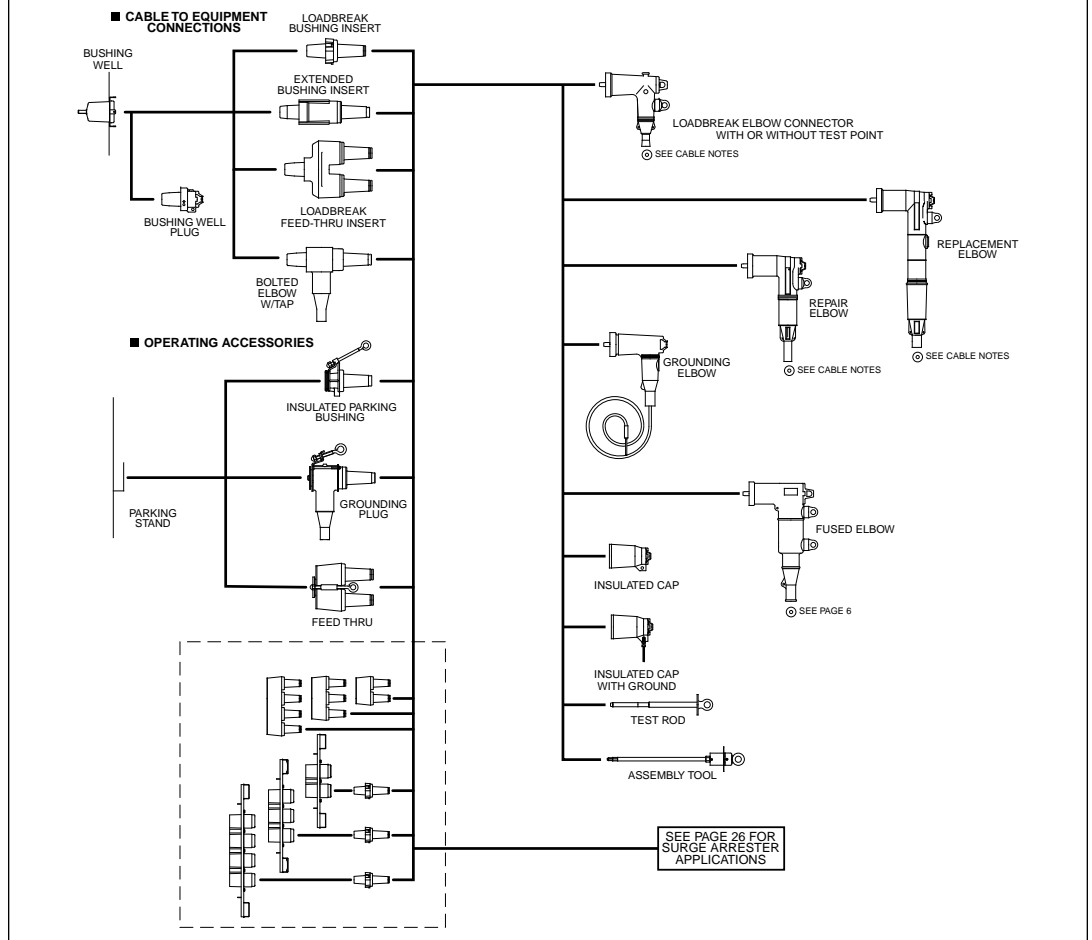

	SEPARABLE CONNECTORS		
DEADFRONT	FUSED ELBOWS	200 AMP LOADBREAK	5-15kV
LIVEFRONT	CABLE JOINTS	200 AMP DEADBREAK	25kV
	TERMINATIONS	600 SERIES DEADBREAK	35kV
	SURGE ARRESTERS		

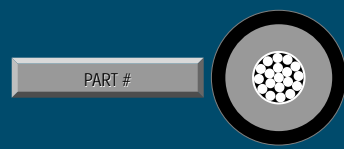

Part numbers that contain the letters W or X are size sensitive. To complete the part number, refer to the W or X tables indicated.

200 AMP LOADBREAK

Illustration (not to scale)	Description	Voltage Class	ELASTIMOLD Part Number	Notes	
	Elbow Connector	15kV	165LR-WX Use Tables W1 and X1	N2,3,4,5	
		25kV	273LR-WX Use Tables W2 and X1	N2,3,4,5	
		35kV	375LR-WX Use Tables W3 and X2	N2,3,5	
	Elbow Connector w/ Test Point	15kV	166LR-WX Use Tables W1 and X1	N2,3,4,5	
		25kV	274LR-WX Use Tables W2 and X1	N2,3,4,5	
		35kV	376LR-WX Use Tables W3 and X2	N2,3,5	
	Repair Elbow Connector	15kV	167ELR-WX Use Tables W5 and X1	N5,10,18	
		25kV	273ELR-WX Use Tables W5 and X1	N5,10,18	
	Repair Elbow Connector w/ Test Point	15kV	168ELR-WX Use Tables W5 and X1	N5,10,18	
		25kV	274ELR-WX Use Tables W5 and X1	N5,10,18	
	Replacement Elbow	15kV	167RLR-WX Use Tables W4 and X1	N5,11,13	
		25kV	273RLR-WX Use Tables W2 and X1	N5,11,13	
	Replacement Elbow w/ Test Point	15kV	168RLR-WX Use Tables W4 and X1	N5,11,13	
		25kV	274RLR-WX Use Tables W2 and X1	N5,11,13	
	Fused Elbow (General Purpose Current Limiting)	15kV	166FLR-WX Use W and X Tables on Page 6	N5,15	
	Bolted Elbow w/ Tap	15kV	167LRT-WX Use Tables W4 and X1	N17	
	Bushing Insert	15kV	1601A4	N4,8	
		25kV	2701A4	N4,8	
		35kV	3701A4	N6	
		35kV	3701A3	N8	
	Extended Bushing Insert	15kV	1601EA4	N8	
		25kV	2701EA4	N8	
	Feed-Thru Insert	15kV	1602A3R	N16	
		25kV	2702A1	N16	
		35kV	3702A1	N6,16	
	Insulated Cap	15kV	160DR		
		Insulated Cap w/ Ground	15kV	160DRG	N7
			25kV	167DRG	N7
	Insulated Cap w/ Ground and Test Point	25kV	273DRG	N7	
		35kV	375DRG	N7	
		35kV	376DRG	N7	
	Grounding Plug (1/0 AWG x 6' Ground Lead)	15kV	161GP		
		25kV	272GP		
	Grounding Elbow (1/0 AWG x 6' Ground Lead)	15kV 25/35kV	160GLR 370GLR	N12	
	Feed-Thru	15kV	164FT		
		25kV	274FT		
		35kV	373FT		
	Feed-Thru Vertical	15kV	164FTV		
		25kV	274FTV		
		35kV	373FTV		

Illustration (not to scale)	Description	Voltage Class	ELASTIMOLD Part Number	Notes
	Feed-Thru Well	15/25kV	K1601WFT	
	Feed-Thru Well Vertical	15/25kV	K1601WFTV	
	Insulated Parking Bushing	15kV	161SOP	
		25kV	272SOP	
		35kV	372SOP	
	Test Rod	ALL	370TR	N9
	Bushing Well Plug	15/25kV	276BWP	
		35kV	M276BWP	
	Assembly Tool	ALL	200AT	N8,9
	Contacts: Long Bi-Metal ELR Bi-Metal Copper LRT Contact RLR Contact	ALL	Use Table X1 02500X	N9
		15/25kV	02509X	N10
		ALL	02702X	N1,9
		15kV	02800X	
		15/25kV	00400X	N11
	Elbow Probe	15kV	166LRF	
		25kV	274LRF	
		35kV	376LRF	
	Elbow Cable Entrance Insulating Plug	ALL	10EP-W Use Table W6	N9
	Cable Size Adapter	15kV	160CA-W Use Table W6 EB-FA Only	N14

- N1. Copper lug for use on COPPER CONDUCTOR ONLY.
- N2. Includes 02500X long bi-metal compression lug as standard.
- N3. Also available as housing only. Specify: 165BLR-W; 273BLR-W; 375BLR-W; 166BLR-W; 274BLR-W; 376BLR-W.
- N4. Also available as elbow/insert combination. Specify: 165A4-WX; 273A4-WX; 166A4-WX; 274A4-WX; 274A4-WX.
- N5. Also available with jacket seal included. Add - "S" suffix to part number. See 200ECS page 28.
- N6. Rated for single-phase applications only.
- N7. Equipped with insulated cuff.
- N8. Includes internal torquing feature using 200AT Assembly Tool.
- N9. Rated for 15kV thru 35kV applications.
- N10. Repair elbow has extended length (3-1/4") contact and elbow housing.
- N11. Replacement elbow has extended length (9-7/8") contact and elbow housing.
- N12. Rated for 25kV thru 35kV applications.
- N13. Includes long bi-metal contact 00400X.
- N14. 160CA Cable Size Adapter can only be used with elbow part numbers 165LR/166LR C size only.
- N15. See page 6 for WX size tables and for fuse sizes.
- N16. Fully rotatable for 360° positioning. Includes bail assembly to secure feed-thru insert to bushing well.
- N17. Includes 02800X long bi-metal contact.
- N18. Includes 02509X long bi-metal contact.

**JUNCTIONS CONTINUED
ON PAGE 6.**

Refer to the **W** and **X** tables on pages 32 and 33 for sizing to cable insulation diameter and conductor size.
For cable shield adapters and jacket seals, see page 28.

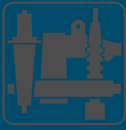

SEPARABLE CONNECTORS

200 AMP LOADBREAK

Cont'd from Pg. 5

RATINGS OVERVIEW

See page 2 for complete information including switching and fault close ratings.

CURRENT RATINGS

200A Continuous
10kA sym. 10 Cycles

VOLTAGE RATINGS

15kV Class

8.3kV Phase-to-Ground
14.4kV Phase-to-Phase
95kV BIL
34kV AC Withstand
53kV DC Withstand
11kV Corona Extinction

25kV Class

15.2kV Phase-to-Ground
26.3kV Phase-to-Phase
125kV BIL
40kV AC Withstand
78kV DC Withstand
19kV Corona Extinction

35kV Class

21.1kV Phase-to-Ground
36.6kV Phase-to-Phase
150kV BIL
50kV AC Withstand
103kV DC Withstand
26kV Corona Extinction

200 AMP LOADBREAK SEPARABLE CONNECTOR COMPONENTS

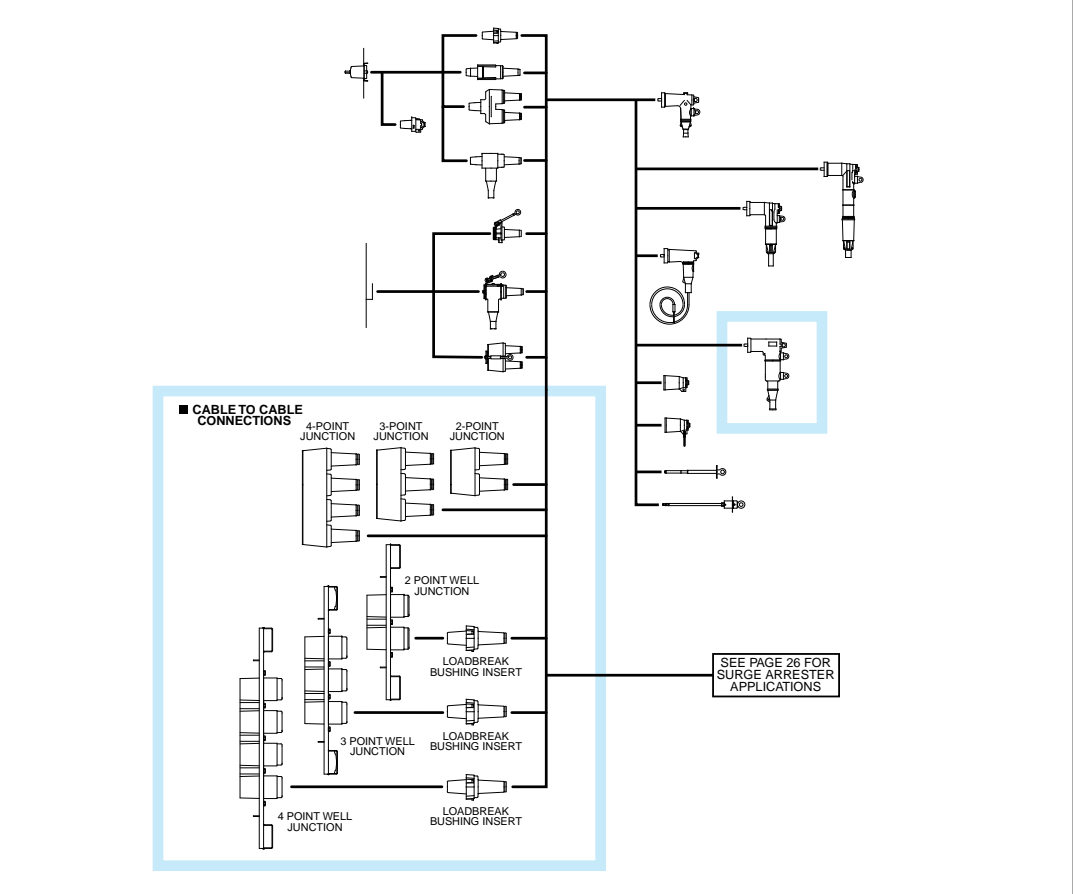

FUSED ELBOW ORDERING INSTRUCTIONS

Step 1 (W)

Determine the insulation diameter of the cable. Select the insulation letter code that best straddles the insulation diameter. Insert code into catalog number.

Step 2 (X)

Choose the proper connector code according to the conductor size. Insert code into the catalog number after the insulation code.

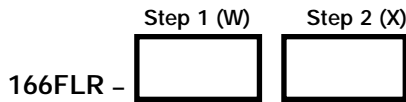

Cable Insulation Diameter Range Inches	Symbol For W
.610 - .735	FAB
.675 - .785	FB
.725 - .835	FG
.775 - .885	GA
.825 - .935	GAB

Conductor Size* (AWG)	Symbol For X	
	Stranded/Compr.	Solid/Compact
2	0220	0210
1	0230	0220
1/0	0240	0230
2/0	0250	0240
3/0	—	0250

*Cu or Al Conductor

ORDERING INSTRUCTIONS FOR FUSE KIT (to be ordered separately)

Determine the ampere rating required. Insert rating into the catalog number below.

166PF8 -

Voltage (kV)	Ampere Rating
8.3	5
	8
	12
	18
	30

The Fused Elbow kit contains the following:

- 1 - Upper elbow half
- 1 - Lower elbow half
- 1 - Upper connector
- 1 - Lower connector
- 1 - Probe
- 1 - Torque-limiting wrench
- 1 - Lubricant
- 1 - Instruction sheet

The Fuse Kit includes the following:

- 1 - Current limiting fuse
- 1 - Allen wrench
- 1 - Air vent rod
- 1 - Instruction sheet

To order replacement parts, specify the following:

- For an upper elbow half, specify 166BFLR-T
- For a lower elbow half, specify 166BFLR-W
- For an upper connector, specify 166-88
- For a lower connector, specify 02600X
- For a probe, specify 166LRF

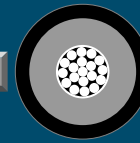

Part numbers that contain the letters **W** or **X** are size sensitive. To complete the part number, refer to the **W** or **X** tables indicated.

200 AMP LOADBREAK

Illustration (not to scale)	Description	Voltage Class	ELASTIMOLD Part Number	Notes
	2-Way Well Junction w/ s.s. Bracket	15/25kV	K1601WJ2	N2
	2-Way Well Junction w/ "U" Straps	15/25kV	K1601WJ2-5	N1, N2
	3-Way Well Junction w/ s.s. Bracket	15/25kV	K1601WJ3	N2
	3-Way Well Junction w/ "U" Straps	15/25kV	K1601WJ3-5	N1, N2
	4-Way Well Junction w/ s.s. Bracket	15/25kV	K1601WJ4	N2
	4-Way Well Junction w/ "U" Straps	15/25kV	K1601WJ4-5	N1, N2
	2-Point Junction with/stainless steel bracket	15kV 25kV 35kV	164J2 274J2 373J2	
	2-Point Junction w/"U"-straps	15kV 25kV 35kV	164J2-5 274J2-5 373J2-5	N1 N1 N1
	3-Point Junction with/stainless steel bracket	15kV 25kV 35kV	164J3 274J3 373J3	
	3-Point Junction w/"U"-straps	15kV 25kV 35kV	164J3-5 274J3-5 373J3-5	N1 N1 N1
	4-Point Junction with/stainless steel bracket	15kV 25kV 35kV	164J4 274J4 373J4	
	4-Point Junction w/"U"-straps	15kV 25kV 35kV	164J4-5 274J4-5 373J4-5	N1 N1 N1

- N1. Also available without straps. Specify suffix "-4" in place of "-5" in the part number.
- N2. Supplied with replaceable stud. Replacement stud available separately. Specify 1601RS.



SEPARABLE CONNECTORS 200 AMP DEADBREAK

200 Amp deadbreak connectors and accessories provide a quick disconnect feature for cable and equipment connections on power distribution systems. All deadbreak connectors must be DE-ENERGIZED before operating and must be mechanically secured with balls when connected. Components can be isolated with insulated caps, plugs and parking bushings.

All deadbreak elbows are equipped with test points as standard. Optional accessories allow system grounding, bypass and lightning surge protection. Additional connecting points and taps can be provided by use of junctions or feed-thrus.

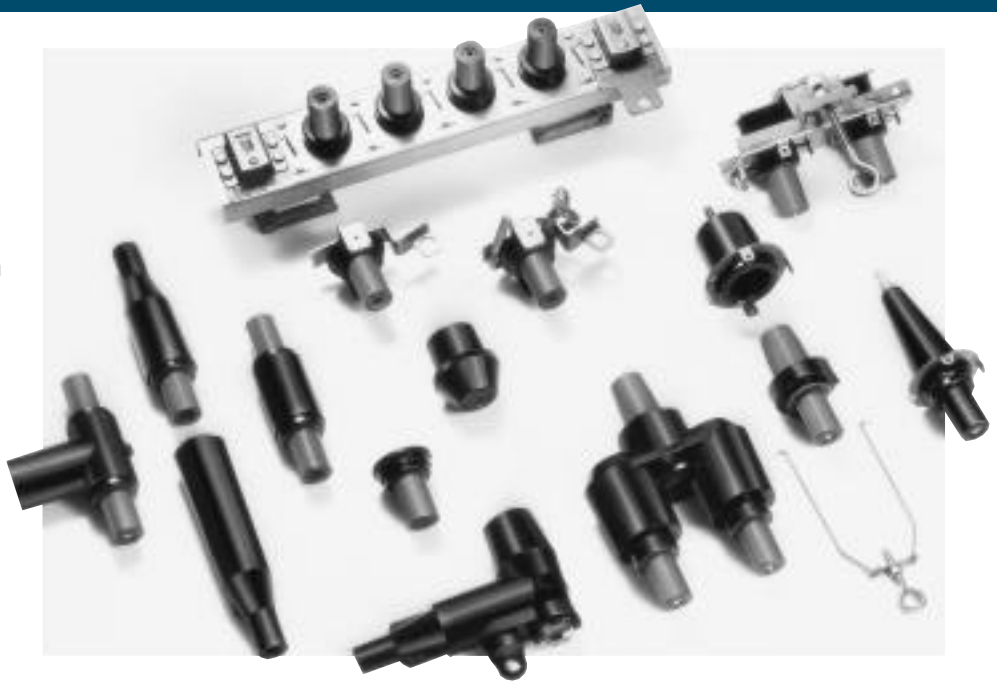

RATINGS OVERVIEW

See page 2 for complete information.

CURRENT RATINGS

200A Continuous
10kA sym. 10 Cycles

VOLTAGE RATINGS

15kV Class

8.3kV Phase-to-Ground
14.4kV Phase-to-Phase
95kV BIL
34kV AC Withstand
53kV DC Withstand
11kV Corona Extinction

25kV Class

15.2kV Phase-to-Ground
26.3kV Phase-to-Ground
125kV BIL
40kV AC Withstand
78kV DC Withstand
19kV Corona Extinction

200 AMP DEADBREAK SEPARABLE CONNECTOR COMPONENTS

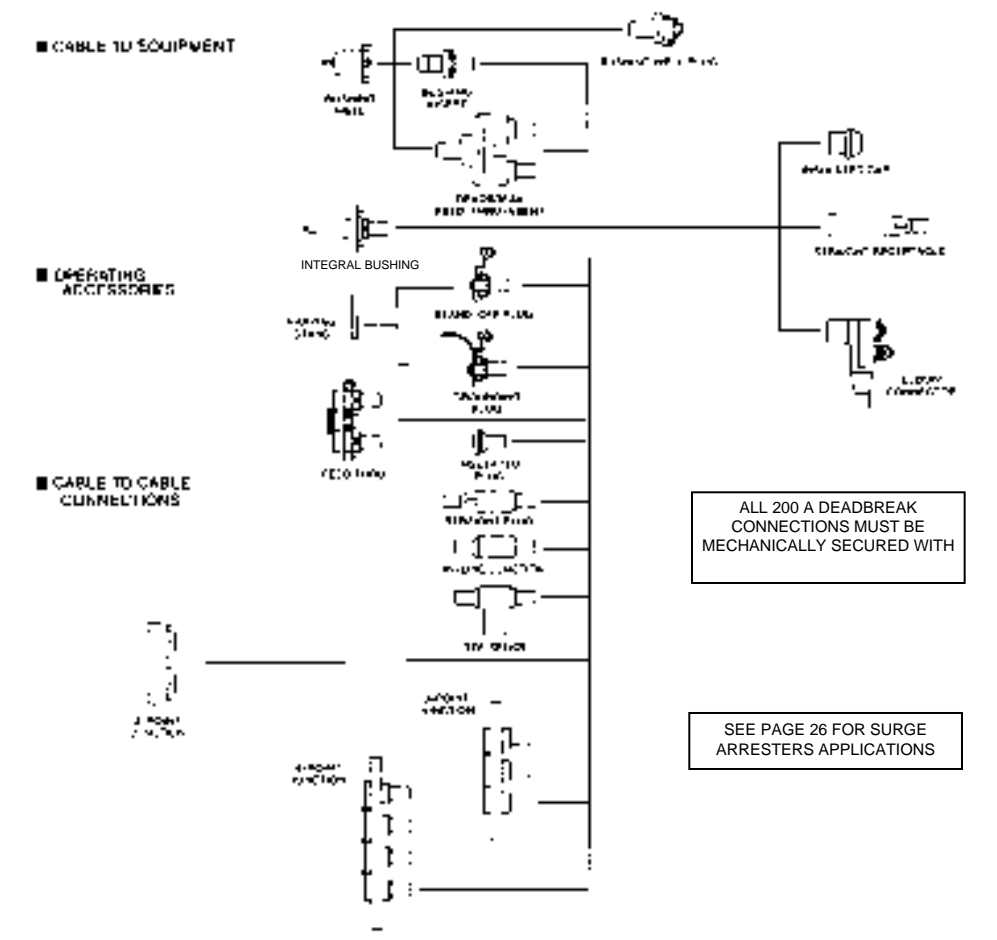

	SEPARABLE CONNECTORS		
DEADFRONT	FUSED ELBOWS	200 AMP LOADBREAK	5-15kV
LIVEFRONT	CABLE JOINTS	200 AMP DEADBREAK	25kV
	TERMINATIONS	600 SERIES DEADBREAK	35kV
	SURGE ARRESTERS		

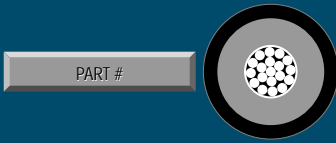

Part numbers that contain the letters **W** or **X** are size sensitive. To complete the part number, refer to the **W** or **X** tables indicated.

200 AMP DEADBREAK

Illustration (not to scale)	Description	Voltage Class	ELASTIMOLD Part Number	Notes
	Elbow Connector w/ Test Point	15/25kV	156LR-WX Use Tables W4 and X1	N1,2
	Bail Assembly for 156LR Elbow	15/25kV	150BA	
	Bushing Insert	15/25kV	K1501A1	N3
	Feed-thru Insert	15/25kV	K1502A1	N3,4
	Insulated Plug	15/25kV	K150DP	N3
	Insulated Cap	15/25kV	K150DR	N3
	Insulated Parking Bushing	15/25kV	K150SOP	N3
	Grounding Plug	15/25kV	151GP	N3
	Feed-Thru	15/25kV	K1501FT	N3,6
	2-Point Junction	15/25kV	K1501J2-U	N3,6
	3-Point Junction	15/25kV	K1501J3-U	N3,6,7
	4-Point Junction	15/25kV	K1501J4-U	N3,6,7
	Elbow Probe	15/25kV	156LRF	
	Straight Receptacle	15/25kV	K151SR-WX Use Tables W6 and X5	N3,12
	Straight Plug	15/25kV	K151SP-WX Use Tables W6 and X5	N3,12
	Tee Splice	15/25kV	K150T	N3
	In-Line Junction	15/25kV	K150S	N3
	Locking Splice	15/25kV	K151LS-WX Use Tables W6 and X8	N8,9
	Locking "Y" Splice	15/25kV	K151LY-WX Use Tables W6 and X8	N8,9
	BAIL	15/25kV	150TB1	N5
	BAIL	15/25kV	150TB2	N5
	BAIL	15/25kV	150TB3	N5

Illustration (not to scale)	Description	Voltage Class	ELASTIMOLD Part Number	Notes
	BAIL	15/25kV	150TB4	N5
	BAIL	15/25kV	150TB5	N5
	Contacts: Long Bi-Metal Copper	15/25kV 15/25kV	02500X 02702X	N7
	Elbow Cable Entrance Insulating Plug	15/25kV	10EP-W Use Table W6	N10
	Cable Entrance Insulating Plug	15/25kV	152EA-W Use Table W6	N11

- N1. Includes bail assembly.
- N2. Includes 02500X long, bi-metal compression lug as standard.
- N3. Bails are required but not included. Order separately. Consult factory for bails not listed for a specific application.
- N4. Fully rotatable for 360° positioning. Includes bail assembly to secure feed-thru insert to bushing well.
- N5. Refer to general catalog for application details.
- N6. Center-to-center spacing equals 4 inches.
- N7. Copper lug for copper cable only.
- N8. To order cable legs for different cable sizes, list each leg size "W" and "X". Example: K151LY-FB240-FB240-FAB220. See Tables W6 and X8 for sizes.
- N9. To order locking contacts for K151LS and K151LY, order 01401X (Al) or 01402X (Cu) for plug contact. Order 01301X (Al) or 01302X (Cu) for receptacle. See Table X8 for sizes.
- N10. For use with 156LR elbows.
- N11. For use with K151SR, K151SP, K151LS, K151LY receptacles, plugs and splices.
- N12. Also available as housing only. Specify K151SPH-W or K151SRH-W.

Refer to the **W** and **X** tables on pages 32 and 33 for sizing to cable insulation diameter and conductor size.
For cable shield adapters and jacket seals, see page 28.

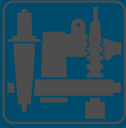

SEPARABLE CONNECTORS 600 SERIES DEADBREAK

600 Series deadbreak elbows, straight receptacles, vault stretchers and accessories are used to connect equipment and cable on primary feeder and network circuits. Designs accommodate large conductors and feature bolted connections and deadfront modular construction for maximum reliability, performance and versatility.

DE-ENERGIZED connectors can be quickly and easily connected and disconnected using standard hand tools and equipment in accordance with accepted operating practices. Optional accessories allow visible external separation, by-pass, isolation, dead-ending, grounding, and testing as well as adding taps, surge arresters and circuit protection.

Hot-stick operable and separable joint systems are shown on pages 14 thru 19.



RATINGS OVERVIEW

See page 2 for complete information.

CURRENT RATINGS

(Prefixes: 650, K650, K655, K656, 750, 755, 756 & 03700)

600 Amp Continuous
25kA sym., 10 cycles

(Prefixes 675, K675, K676, 775, 776 & 03702)

900 Amp Continuous
25kA sym., 10 cycles

NOTE: 900 Amp ratings require copper cable and copper current-carrying components.

VOLTAGE RATINGS

15/25kV Class (5kV thru 28kV)

16.2kV Phase-to-Ground

28kV Phase-to-Phase

140kV BIL

45kV AC Withstand

84kV DC Withstand

21.5kV Corona Extinction

35kV Class

21.1kV Phase-to-Ground

36.6kV Phase-to-Phase

150kV BIL

50kV AC Withstand

103kV DC Withstand

26kV Corona Extinction

Note: Elastimold has increased the IEEE Standard Production and Design Test levels for 25kV Class products to include 27kV and 28kV systems.

SEPARABLE CONNECTORS 600 SERIES DEADBREAK

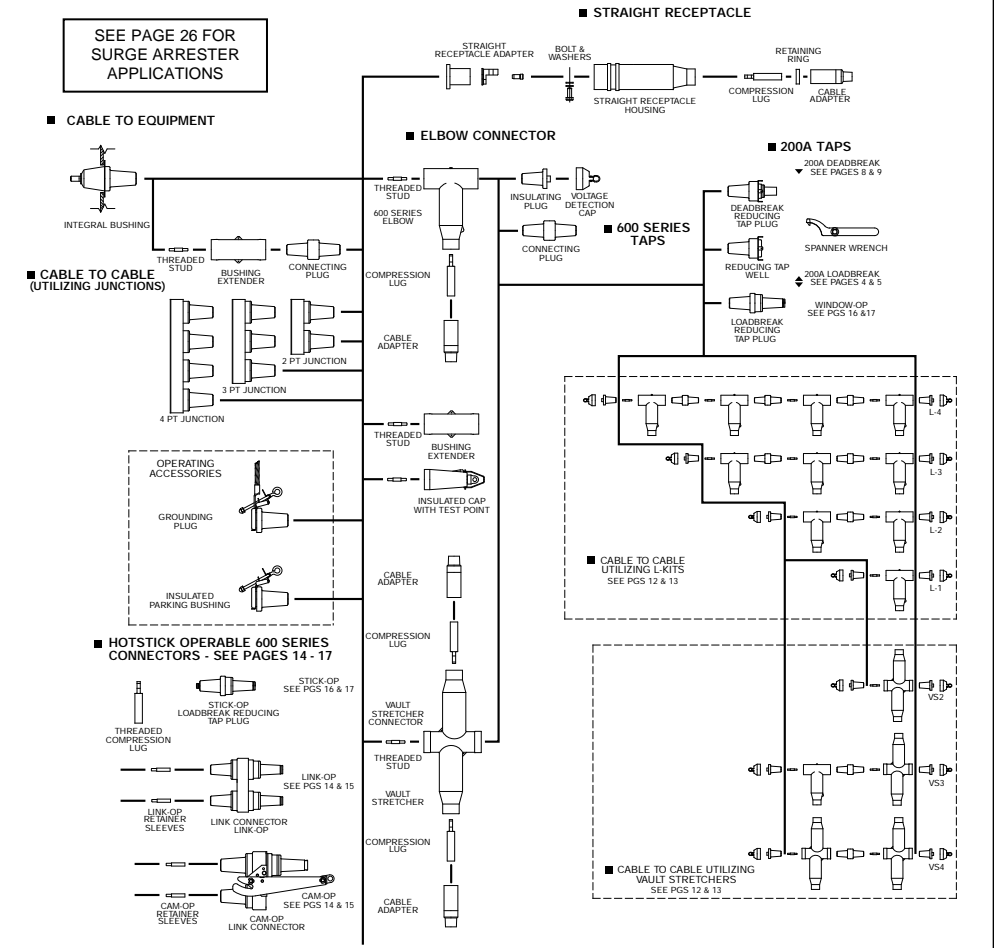

	SEPARABLE CONNECTORS		
DEADFRONT	FUSED ELBOWS	200 AMP LOADBREAK	5-15kV
LIVEFRONT	CABLE JOINTS	200 AMP DEADBREAK	25kV
	TERMINATIONS	600 SERIES DEADBREAK	35kV
	SURGE ARRESTERS		

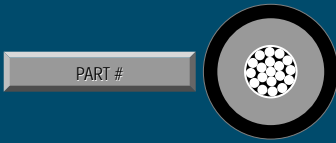

Part numbers that contain the letters W or X are size sensitive. To complete the part number, refer to the W or X tables indicated.

600 SERIES DEADBREAK

Illustration (not to scale)	Description	Voltage Class	ELASTIMOLD Part Number	Notes
	600 Series Elbow (w/ Insul. Plug, Cap, Stud, Lug & Cable Adapter)	15/25kV 35kV	K655LR-W0X Use Tables W7 and X6 755LR-W0X Use Tables W9 and X6	N1,2 N1,2
	600 Series Elbow w/ Test Point (w/ Insul. Plug, Cap, Stud, Lug & Cable Adapter)	15/25kV 35kV	K656LR-W0X Use Tables W7 and X6 756LR-W0X Use Tables W9 and X6	N1,2 N1,2
	600 Series Elbow Housing only (w/ Stud)	15/25kV 35kV	K655BLR 755BLR	N1,3 N1,3
	600 Series Elbow w/ Test Point (Housing only w/ Stud)	15/25kV 35kV	K656BLR 756BLR	N1,3 N1,3
	600 Series Straight Receptacle (w/Cable Adapter, Lug & Retaining Ring)	15/25kV	K655SR-W0X Use Tables W7 and X6	N1,2,12
	600 Series Straight Receptacle Housing (Lug & Cable Adapter not included)	15/25kV	K655BSR	N1,12
	Straight Receptacle Adapter	15/25kV	K650SRA	N1,4
	600 Series Vault Stretcher (Housing only w/ Stud)	15/25kV	K655BVS	N1,9
	Cable Size Adapter	15/25kV 35kV	655CA-W Use Table W7 755CA-W Use Table W9	
	Compression Lug	ALL	03700X Use Table X6 03702X Use Table X6	N5 N6
	600 Series Elbow Size Sensitive Kit (Cable Adapter & Lug)	15/25kV 35kV	655CK-W0X Use Tables W7 and X6 755CK-W0X Use Tables W9 and X6	N2 N2
	Adapter Retaining Ring	ALL	650ARR-X Use Table X6	
	600 Series Straight Receptacle Size Sensitive Kit (Cable Adapter, Retaining Ring & Lug)	15/25kV 35kV	655CK-W0X-ARR Use Tables W7 and X6 755CK-W0X-ARR Use Tables W9 and X6	N2 N2
	Bushing Extender (w/ Stud)	15/25kV 35kV	K655BE 755BE	N1,3 N1,3
	Insulated Cap w/ Test Point (w/ Stud)	15/25kV	K656DR	N3,7
	Insulating Plug (w/ Cap)	15/25kV 35kV	K650BIP 750BIP	N1,7,8 N1,7,8
	Grounding Plug (Ground Lead 2/0 AWG x 30")	15/25kV 35kV	650GP 750GP	N1,7,8 N1,7,8
	Insulated Parking Bushing	15/25kV 35kV	K650SOP 750SOP	N7,8 N7,8
	Connecting Plug	15/25kV 35kV	K650CP 750CP	N1,7,8,9 N1,7,8,9

Illustration (not to scale)	Description	Voltage Class	ELASTIMOLD Part Number	Notes
	Deadbreak Reducing Tap Plug	15/25kV	K650RTP	N1,7,8,9
	Reducing Tap Well	15/25kV	K650RTW	N1,7,8,9
	Loadbreak Reducing Tap Plug	15kV 25kV 35kV	650ETP K650ETP 750ETP	N1,7,8,10,13 N1,7,8,10,13 N1,7,8,10,13
	Vault Stretcher Threaded Stud	15/25kV	650VSA	N1
	600 Series Elbow Threaded Stud	15/25kV 35kV	650SA 750SA	N1 N1
	Assembly Tool	ALL	600AT	N10
	Spanner Wrench	ALL	600SW	N9
	2-Point Junction	15/25kV 35kV	K650J2 750J2	N1,11 N1,11
	3-Point Junction	15/25kV 35kV	K650J3 750J3	N1,11 N1,11
	4-Point Junction	15/25kV 35kV	K650J4 750J4	N1,11 N1,11

N1. For 900 Amp ratings, substitute 675 for 650 and 655; 676 for 656; K675 for K650 and K655; K676 for K656; 775 for 750 and 755; 776 for 756 and 2X for 0X in the part number. The 900 Amp rating requires copper current-carrying connector components and copper conductor cable.

N2. Add suffix symbol from page 29 to include cable shield grounding kit and/or cable jacket sealing kit.

N3. Available without the stud by adding "N" to the part number.

N4. Straight Receptacle Adapter is used to connect Straight Receptacles K655YBSR and K655YSR-W0X (Pg.14) to equipment bushings.

N5. Aluminum lug for use on aluminum or copper conductors. DO NOT substitute threaded 03600X lug.

N6. Copper lug for use on COPPER CONDUCTOR ONLY. DO NOT substitute threaded 03602X lug.

N7. Available with the stud factory-assembled by adding "SP" to the part number.

N8. Available with a loose stud by adding suffix "S" to the part number.

N9. 600SW spanner wrench is recommended for installation of connecting plugs, deadbreak reducing tap plugs and reducing tap wells..

N10. 600AT assembly tool is required for installation of loadbreak reducing tap plugs.

N11. Rubber junction with stainless steel mounting plate and back plate. Add "-U" for rubber junction with stainless steel mounting plate, back plate and adjustable bracket.

Add "-4" for rubber junction only.
Add "-5" for rubber junction, stainless steel U-straps and back plate.

N12. 600 Series Elbows and Straight Receptacles with IEEE Std. 386 capacitive test points are available by substituting 656 for 655; K656 for K655; K676 for K675; 756 for 755; 676 for 675; K676 for K675 and 776 for 775 in the part number.

N13. See page 17 for Window-Op Connector Kit.

Refer to the **W** and **X** tables on pages 32 and 33 for sizing to cable insulation diameter and conductor size.

For cable shield adapters and jacket seals, see page 28.

SEPARABLE CONNECTORS

600 SERIES DEADBREAK Cont'd from Pg. 11

600 Series deadbreak elbows, straight receptacles, vault stretchers and accessories are used to connect equipment and cable on primary feeder and network circuits. Designs accommodate large conductors and feature bolted connections and deadfront modular construction for maximum reliability, performance and versatility.

DE-ENERGIZED connectors can be quickly and easily connected and disconnected using standard hand tools and equipment in accordance with accepted operating practices. Optional accessories allow visible external separation, by-pass, isolation, dead-ending, grounding, and testing as well as adding taps, surge arresters and circuit protection.

Hot-stick operable and separable joint systems are shown on pages 14 thru 19.



RATINGS OVERVIEW

See page 2 for complete information.

CURRENT RATINGS

(Prefixes: 650, K650, K655, K656, 750, 755, 756 & 03700)

600 Amp Continuous
25kA sym., 10 cycles

(Prefixes 675, K675, K676, 775, 776 & 03702)

900 Amp Continuous
25kA sym., 10 cycles

NOTE: 900 Amp ratings require copper cable and copper current-carrying components.

VOLTAGE RATINGS

15/25kV Class (5kV thru 28kV)

16.2kV Phase-to-Ground

28kV Phase-to-Phase

140kV BIL

45kV AC Withstand

84kV DC Withstand

21.5kV Corona Extinction

35kV Class

21.1kV Phase-to-Ground

36.6kV Phase-to-Phase

150kV BIL

50kV AC Withstand

103kV DC Withstand

26kV Corona Extinction

Note: Elastimold has increased the IEEE Standard Production and Design Test levels for 25kV Class products to include 27kV and 28kV systems.

SEPARABLE CONNECTORS 600 SERIES DEADBREAK

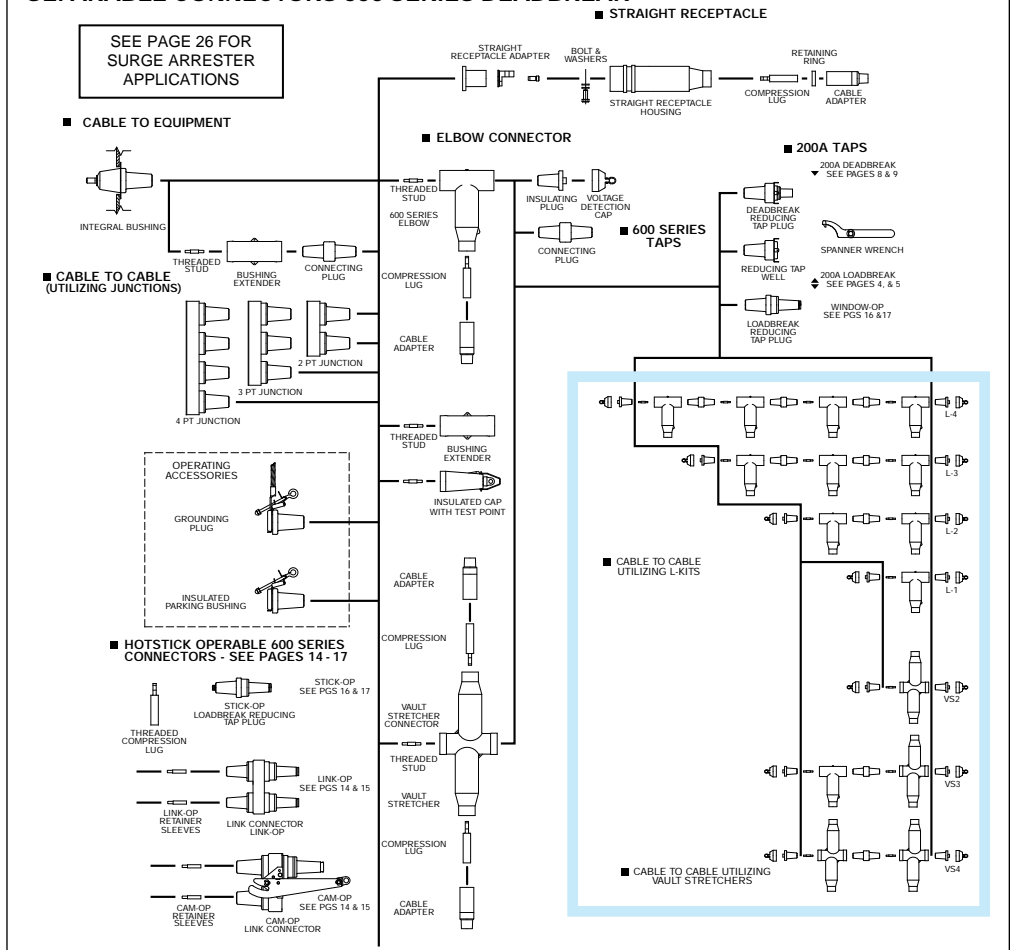

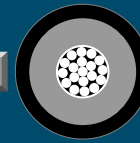

Part numbers that contain the letters **W** or **X** are size sensitive. To complete the part number, refer to the **W** or **X** tables indicated.

600 SERIES DEADBREAK

Illustration (not to scale)	Description	Voltage Class	ELASTIMOLD Part Number	Notes
	1-way L-Kit	15/25kV 35kV	K655L1 755L1	N1,2,3,4 N1,2,3,4
	2-way L-Kit	15/25kV 35kV	K655L2 755L2	N1,2,3,4 N1,2,3,4
	2-way VS-Kit	15/25kV	K655VS2	N1,2,3
	3-way L-Kit	15/25kV 35kV	K655L3 755L3	N1,2,3,4 N1,2,3,4
	3-Way VS Kit	15/25kV	K655VS3	N1,2,3
	4-Way L-Kit	15/25kV 35kV	K655L4 755L4	N1,2,3,4 N1,2,3,4
	4-Way VS-Kit	15/25kV	K655VS4	N1,2,3
	Spanner Wrench	ALL	600SW	N2

- N1. For 900 Amp ratings, substitute 675 for 650 and 655; 676 for 656; K675 for K650 and K655; K676 for K656; 775 for 750 and 755; 776 for 756 and 2X for 0X in the part number. The 900 Amp rating requires copper current-carrying connector components and copper conductor cable.
- N2. 600SW spanner wrench is recommended for installation of connecting plugs, deadbreak reducing tap plugs and reducing tap wells.
- N3. L-Kits and VS-Kits do not include cable adapters, compression lugs or adapter retaining rings. These items must be ordered separately.
- N4. 600 Series Elbows and Straight Receptacles with IEEE Std. 386 capacitive test points are available by substituting 656 for 655; K656 for K655; K676 for K675; 756 for 755; 676 for 675; K676 for K675 and 776 for 775 in the part number.

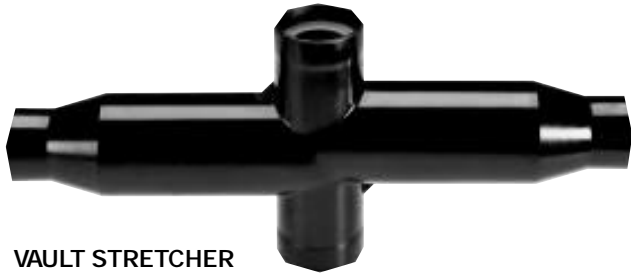

VAULT STRETCHER

Provides an alternate method of splicing and joining various types and styles of cables using standard 600 Series components.

Refer to the **W** and **X** tables on pages 32 and 33 for sizing to cable insulation diameter and conductor size.

For cable shield adapters and jacket seals, see page 28.

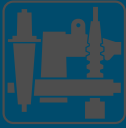

SEPARABLE CONNECTORS CAM-OP, LINK-OP 600 SERIES DEADBREAK

Elastimold's 600 Series Cam-Op™, and Link-Op™ deadbreak connector systems incorporate provisions for hotstick operation of DE-ENERGIZED primary feeder or network circuits. Configurations allow external visible break, testing, grounding and isolation. Retrofit kits allow upgrading existing equipment.

Cam-Op systems utilize pin and socket connectors. Link-Op connectors are bolted and installed using torque controlled tools. Either system can be retrofitted to existing equipment.

The Cam-Op and Link-Op connectors are unique, allowing all hotstick operations to be completed without moving the cable, an important consideration when large, stiff cables prohibit movement.

The Cam-Op connector is easily installed or removed by hotstick operation of the cam action disconnect lever.



RATINGS OVERVIEW

See page 2 for complete information.

CURRENT RATINGS

600 & 900 Amp Continuous
25kA sym., 10 cycles

NOTE: 900 Amp ratings require copper cable and copper current-carrying components.

CONTINUOUS VOLTAGE RATINGS

15kV Class

8.3kV Phase-to-Ground
14.4kV Phase-to-Phase
95kV BIL

34kV AC Withstand
53kV DC Withstand
11kV Corona Extinction

25kV Class

15.2kV Phase-to-Ground
26.3kV Phase-to-Phase
125kV BIL

40kV AC Withstand
78kV DC Withstand
19kV Corona Extinction

35kV Class

21.1kV Phase-to-Ground
36.6kV Phase-to-Phase
150kV BIL

50kV AC Withstand
103kV DC Withstand
26kV Corona Extinction

CAM-OP & LINK-OP SYSTEM – 600 SERIES DEADBREAK

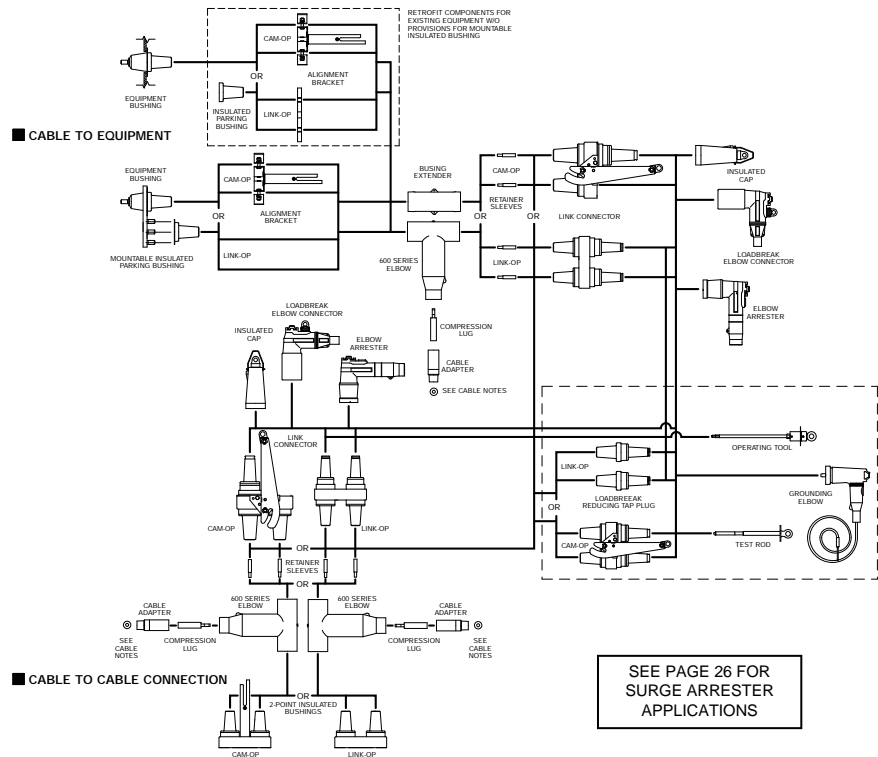

DEADFRONT	SEPARABLE CONNECTORS	200 AMP LOADBREAK	5-15kV	PART #
LIVEFRONT	FUSED ELBOWS	200 AMP DEADBREAK	25kV	
	CABLE JOINTS	600 SERIES DEADBREAK	35kV	
	TERMINATIONS			
	SURGE ARRESTERS			

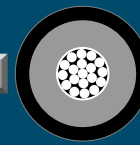

Part numbers that contain the letters W or X are size sensitive. To complete the part number, refer to the W or X tables indicated.

CAM-OP™ & LINK-OP™

Illustration (not to scale)	Description	Voltage Class	ELASTIMOLD Part Number	Notes
	CAM-OP CONNECTOR KIT	15kV 25kV 35kV	655LINK-C-LR-WOX-B-DRG Use Tables W7 and X6 K655LINK-C-LR-WOX-B-DRG Use Tables W7 and X6 755LINK-C-LR-WOX-B-DRG Use Tables W9 and X6	N1,3,11, 13,14,18 N1,3,11, 13,14,18 N1,3,11, 13,14,18
	LINK-OP CONNECTOR KIT	15kV 25kV 35kV	655LINK-B-LR-WOX-B-DRG Use Tables W7 and X6 K655LINK-B-LR-WOX-B-DRG Use Tables W7 and X6 755LINK-B-LR-WOX-B-DRG Use Tables W9 and X6	N2,3,11,12 13,14,18 N2,3,11, 13,14,18 N2,3,11, 13,14,18
	Mountable Insulated Bushing	25kV 35kV	K650LBM-3 750LBM-3	N3 N3
	RETROFIT CAM-OP CONNECTOR KIT	15kV 25kV 35kV	655LINK-C-LR-WOX-A-DRG Use Tables W7 and X6 K655LINK-C-LR-WOX-A-DRG Use Tables W7 and X6 755LINK-C-LR-WOX-A-DRG Use Tables W9 and X6	N5,11,13 14,18 N5,11,13 14,18 N5,11,13 14,18
	RETROFIT LINK-OP CONNECTOR KIT	15kV 25kV 35kV	655LINK-B-LR-WOX-A-DRG Use Tables W7 and X6 K655LINK-B-LR-WOX-A-DRG Use Tables W7 and X6 755LINK-B-LR-WOX-A-DRG Use Tables W9 and X6	N6,11,12, 13,14,18 N6,11,12, 13,14,18 N6,11,12, 13,14,18
	Insulating Plug	25kV 35kV	K650LB 750LB	N4 N4
	CAM-OP Alignment Bracket	15kV 25kV 35kV	650CAB K650CAB 750CAB	
	LINK-OP Alignment Bracket (Retrofit LINK-OP Only)	ALL ALL	650AB 650ABV	N15 N15
	Compression Lug	ALL ALL	03700X Use Table X6 03702X Use Table X6	N7 N8
	CAM-OP & LINK-OP Size Sensitive Kit (Cable Adapter & Lug)	15/25kV 35kV	655CK-WOX Use Tables W7 and X6 755CK-WOX Use Tables W9 and X6	N13 N13
	CAM-OP Retaining Sleeve	ALL	650RSC	N11
	LINK-OP Retaining Sleeve	ALL	650RS	N11
	CAM-OP CABLE JOINT KIT	15kV 25kV 35kV	655BI-LINK-C-LR-WOX-DRG Use Tables W7 and X6 K655BI-LINK-C-LR-WOX-DRG Use Tables W7 and X6 755BI-LINK-C-LR-WOX-DRG Use Tables W9 and X6	N9,11,13 14,18 N9,11,13 14,18 N9,11,13 14,18
	LINK-OP CABLE JOINT KIT	15kV 25kV 35kV	655BI-LINK-B-LR-WOX-DRG Use Tables W7 and X6 K655BI-LINK-B-LR-WOX-DRG Use Tables W7 and X6 755BI-LINK-B-LR-WOX-DRG Use Tables W9 and X6	N10,11,12, 13,14,18 N10,11,12, 13,14,18 N10,11,12, 13,14,18
	CAM-OP Loadbreak Reducing Tap Plugs (Visi-Break)	15kV 25kV 35kV	650LK-C-VB K650LK-C-VB 750LK-C-VB	
	LINK-OP Loadbreak Reducing Tap Plug	15kV 25kV 35kV	650LT-B K650LT-B 750LT-B	N11

Illustration (not to scale)	Description	Voltage Class	ELASTIMOLD Part Number	Notes
	Grounding Elbow (1/0 AWG x 6' Ground Lead)	15kV 25kV 35kV	160GLR 370GLR 370GLR	N19 N19
	Test Rod	ALL	370TR	
	Assembly Tool	ALL	600AT	N11
	CAM-OP OPERATING KIT	15kV 25kV 35kV	650CAM-OK K650CAM-OK 750CAM-OK	N16 N16 N16
	LINK-OP OPERATING KIT	15kV 25kV 35kV	650LINK-OK K650LINK-OK 750LINK-OK	N17 N17 N17

- N1. Cam-Op connector kit includes: 1- Cam-Op link; 1- elbow housing; 1- cable adapter; 1-0370 style lug; 1- bushing extender; 2- retainer sleeves; 1- insulated cap; 1- mountable insulated bushing and 1- alignment bracket.
- N2. Link-Op connector kit includes: 1- Link-Op link; 1- elbow housing; 1- cable adapter; 1-0370 style lug; 1- bushing extender; 2- retainer sleeves; 2- insulated caps; and 1- mountable insulated bushing.
- N3. Mountable insulated bushing included with Cam-Op and Link-Op connector kit. Requires 3 threaded studs on equipment faceplate for installation.
- N4. Use with the Retrofit Cam-Op and Retrofit Link-Op connector kit.
- N5. Retrofit Cam-Op connector kit includes: 1- link; 1- elbow housing; 1- cable adapter; 1-0370 style lug; 1- bushing extender; 2- retainer sleeves; 1- insulated cap; 1- insulating plug; and 1- alignment bracket.
- N6. Retrofit Link-Op connector kit includes: 1- link; 1- elbow housing; 1- cable adapter; 1-0370 style lug; 1- bushing extender; 2- retainer sleeves; 2- insulated caps; 1- insulating plug; and 1- alignment bracket.
- N7. Aluminum lug for use on aluminum or copper conductors. DO NOT substitute threaded 03600X lug.
- N8. Copper lug for use on COPPER CONDUCTOR ONLY. DO NOT substitute 03602X threaded lug.
- N9. Cam-Op Cable Joint Kit includes: 1- Cam-Op link; 1- Cam-Op BI-SOP; 2- elbow housings; 2- cable adapters; 2- 0370 style lugs; 2- retainer sleeves; 1- insulated cap.
- N10. Link-Op Cable Joint Kit includes: 1- Link-Op link; 1- Link-Op BI-SOP; 2- elbow housings; 2- cable adapters; 2- 0370 style lugs; 2- retainer sleeves; 2- insulated caps.
- N11. 600AT assembly tool required for operation and/or installation.
- N12. For 900 Amp ratings, substitute 675 for 650 and 655; 676 for 656; K675 for K650 and K655; K676 for K656; 775 for 750 and 755; 776 for 756 and 2X for 0X in the part number. The 900 Amp rating requires copper current-carrying connector components and copper conductor cable.
- N13. Add suffix symbol from page 29 to include cable shield grounding kit and/or cable jacket sealing kit.
- N14. To add elbows or arresters instead of insulating caps, replace the "DRG" with "LR-WX" for elbows (with test point) or "ESA" for elbow arresters.
- N15. The 650ABV is required when the bushing horizontal spacing on the equipment or junctions is less than 5".
- N16. Cam-Op operating kit includes accessories that enable visible break, testing, isolation and grounding functions to be performed. Kit includes: 3- Cam-Op loadbreak reducing tap plugs; 3- grounding elbows; 1- assembly tool; 1- test rod; 1- carry case; 1- lubricant; 1- instructions.
- N17. Link-Op operating kit includes accessories that enable visible break, testing, isolation and grounding functions to be performed. Kit includes: 6- Link-Op loadbreak reducing tap plugs; 3- grounding elbows; 1- assembly tool; 1- test rod; 1- carry case; 1- lubricant; 1- instructions.
- N18. 600 Series Elbows and Straight Receptacles with IEEE Std. 386 capacitive test points are available by substituting 656 for 655; K656 for K655; K676 for K675; 756 for 755; 676 for 675; K676 for K675 and 776 for 775 in the part number.
- N19. Rated for both 25kV and 35kV applications.

Refer to the **W** and **X** tables on pages 32 and 33 for sizing to cable insulation diameter and conductor size.

For cable shield adapters and jacket seals, see page 28.



SEPARABLE CONNECTORS STICK-OP, WINDOW-OP 600 SERIES DEADBREAK

Elastimold's 600 Series Window-Op™ and Stick-Op™ deadbreak connector systems incorporate provisions for hotstick operation of DE-ENERGIZED primary feeder or network circuits.

The Window-Op and Stick-Op connectors allow direct testing and grounding with no required cable movement.

Window-Op is ideal for equipment applications which include viewing windows to provide an internal visible break that does not require hot stick removal of the elbows.

Stick-Op provides an external visible break by hot stick removal of the elbow.

Window-Op and Stick-Op connectors are bolted and installed using torque controlled tools.

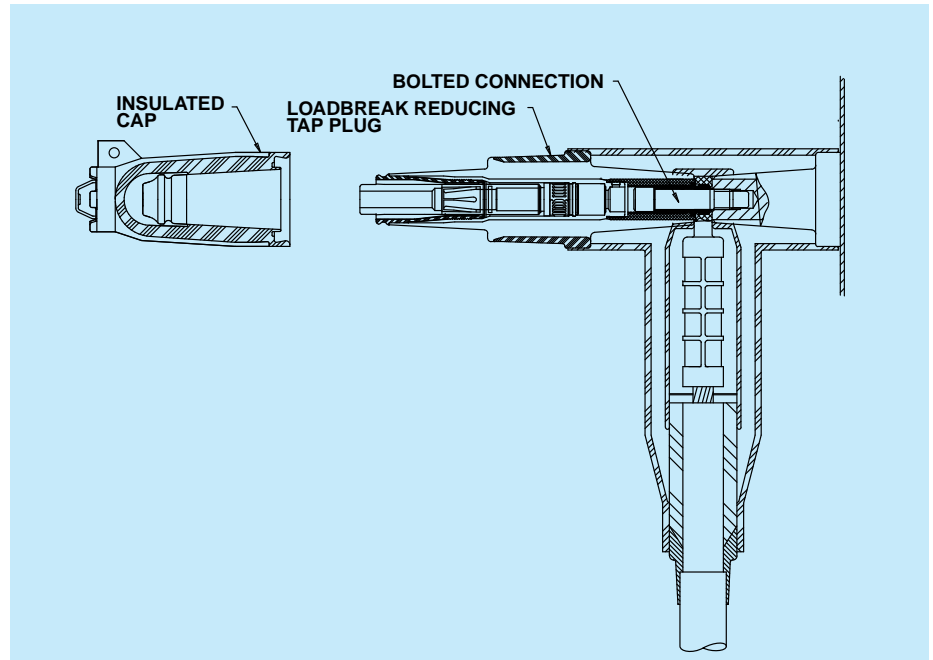

RATINGS OVERVIEW

See page 2 for complete information.

CURRENT RATINGS

600 & 900 Amp Continuous
25kA sym., 10 cycles

NOTE: 900 Amp ratings require copper cable and copper current-carrying components.

CONTINUOUS VOLTAGE RATINGS

15kV Class

8.3kV Phase-to-Ground
14.4kV Phase-to-Phase
95kV BIL
34kV AC Withstand
53kV DC Withstand
11kV Corona Extinction

25kV Class

15.2kV Phase-to-Ground
26.3kV Phase-to-Phase
125kV BIL
40kV AC Withstand
78kV DC Withstand
19kV Corona Extinction

35kV Class

21.1kV Phase-to-Ground
36.6kV Phase-to-Phase
150kV BIL
50kV AC Withstand
103kV DC Withstand
26kV Corona Extinction

STICK-OP & WINDOW-OP SYSTEM – 600 SERIES DEADBREAK

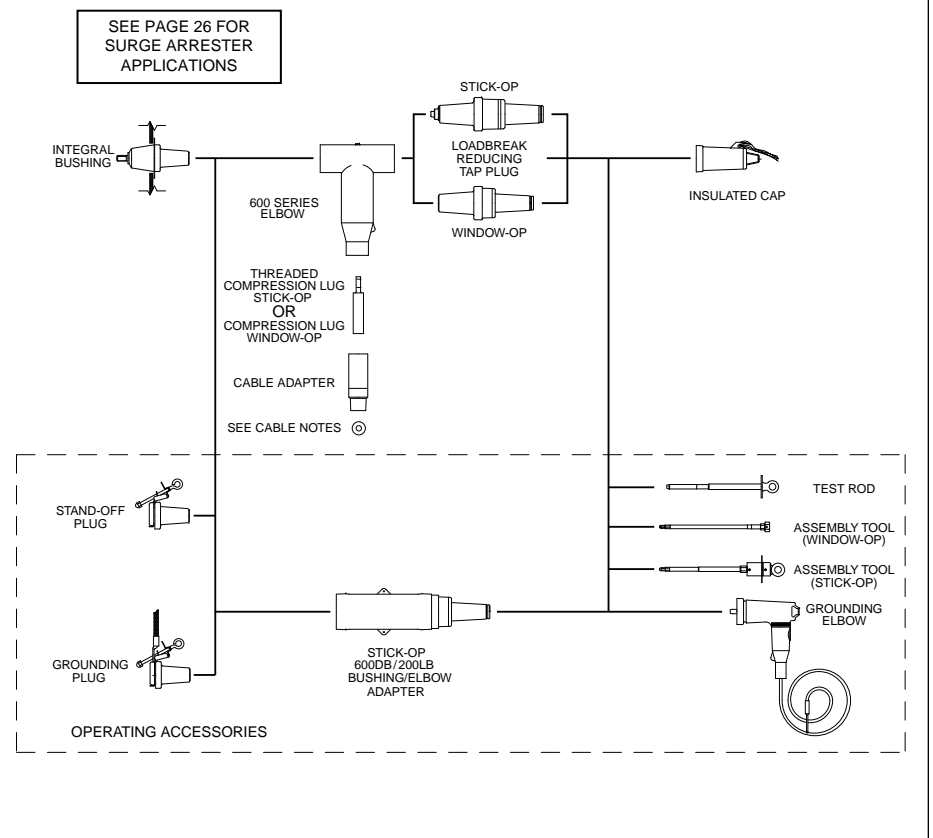

	SEPARABLE CONNECTORS		
DEADFRONT	FUSED ELBOWS	200 AMP LOADBREAK	5-15kV
LIVEFRONT	CABLE JOINTS	200 AMP DEADBREAK	25kV
	TERMINATIONS	600 SERIES DEADBREAK	35kV
	SURGE ARRESTERS		

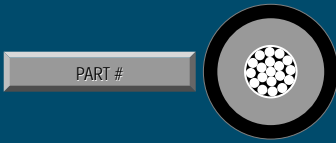

Part numbers that contain the letters **W** or **X** are size sensitive. To complete the part number, refer to the **W** or **X** tables indicated.

STICK-OP™ & WINDOW-OP™

Illustration (not to scale)	Description	Voltage Class	ELASTIMOLD Part Number	Notes
	WINDOW-OP CONNECTOR KIT	15kV 25kV 35kV	655ETP-W0X-DRG Use Tables W7 and X6 K655ETP-W0X-DRG Use Tables W7 and X6 755ETP-W0X-DRG Use Tables W9 and X6	N1,3,4,5,6,13
	STICK-OP CONNECTOR KIT	15kV 25kV 35kV	655LRTP-W0X-DRG Use Tables W7 and X6 K655LRTP-W0X-DRG Use Tables W7 and X6 755LRTP-W0X-DRG Use Tables W9 and X6	N2,3,4,5,8,13
	WINDOW-OP Loadbreak Reducing Tap Plug	15kV 25kV 35kV	650ETP K650ETP 750ETP	N4,15 N4,15 N4,15
	STICK-OP Loadbreak Reducing Tap Plug	15kV 25kV 35kV	650LRTPA3 K650LRTPA2 750LRTPA2	N3,4
	STICK-OP Bushing Adapter	15kV 25kV 35kV	650BEA3 K650BEA2 750BEA2	N3,4
	Compression Lug	ALL	03700X Use Tables X6	N6
	WINDOW-OP Compression Lug	ALL	03702X Use Tables X6	N7
	Threaded Compression Lug	ALL	03600X Use Tables X6	N8
	STICK-OP Threaded Compression Lug	ALL	03602X Use Tables X6	N9
	WINDOW-OP Size Sensitive Kit (Cable Adapter & Lug)	15/25kV 35kV	655CK-W0X Use Tables W7 and X6 755CK-W0X Use Tables W9 and X6	N5 N5
	STICK-OP Size Sensitive Kit (Cable Adapter & Threaded Lug)	15/25kV 35kV	655TCK-W0X Use Tables W7 and X6 755TCK-W0X Use Tables W9 and X6	N5 N5
	Extraction Tool	ALL	600ET	N3,10
	Grounding Elbow (1/0 AWG x 6' Ground Lead)	15kV 25kV 35kV	160GLR 370GLR 370GLR	N14 N14
	Test Rod	ALL	370TR	
	Assembly Tool (Stick-Op)	ALL	600AT	N3
	Assembly Tool (Window-Op)	ALL	600ATM	N15
	STICK-OP OPERATING KIT	15kV 25kV 35kV	650STICK-OK K650STICK-OK 750STICK-OK	N11 N11 N11
	WINDOW-OP OPERATING KIT	15kV 25kV 35kV	650WINDOW-OK K650WINDOW-OK 750WINDOW-OK	N12 N12 N12

- N1. Window-Op Kit includes: insulated cap; Window-Op reducing tap plug; 600 Series elbow housing; cable adapter; and 0370 style compression lug.
- N2. Stick-Op Kit includes insulated cap; Stick-Op Loadbreak reducing tap plug; 600A Elbow Housing; cable adapter; and threaded 0360 style compression lug.
- N3. 600AT assembly tool required for operation and/or installation.
- N4. For 900 Amp ratings, substitute 675 for 650 and 655; 676 for 656; K675 for K650 and K655; K676 for K656; 775 for 750 and 755; 776 for 756 and 2X for 0X in the part number. The 900 Amp rating requires copper current-carrying connector components and copper conductor cable.
- N5. Add suffix symbol from page 29 to include cable shield grounding kit and/or cable jacket sealing kit.
- N6. Aluminum lug for use on aluminum or copper conductors. DO NOT substitute threaded 03600X lug.
- N7. Copper lug for use on COPPER CONDUCTOR ONLY. DO NOT substitute 03602X threaded lug.
- N8. Threaded aluminum lug (Stick-Op only) for use on copper or aluminum conductors. DO NOT substitute unthreaded 03700X lugs. DO NOT use with 675, 676, K675, K676, 775 or 776 part numbers.
- N9. Threaded copper lug (Stick-Op only) for use on copper conductors only. DO NOT substitute unthreaded 03702X lugs.
- N10. Required to disassemble Stick-Op loadbreak reducing tap plug from the threaded compression lug and 600 Series elbow after the shear-pin is broken during assembly.
- N11. Stick-Op Operating Kit includes accessories that enable visible break direct testing, isolation, and grounding functions to be performed. Kit includes: 3-insulated parking bushings; 3-grounding elbows; 3-600DB/200LB bushing/elbow adapters; 1-assembly tool; 1-test rod; 1-carry case; 1-lubricant; 1-instructions.
- N12. Window-Op Operating Kit includes accessories that enable visible grounding and direct testing functions to be performed. Kit includes: 3-grounding elbows; 1-test rod; 1-carry case; 1-lubricant; 1-instructions.
- N13. 600 Series Elbows and Straight Receptacles with IEEE Std. 386 capacitive test points are available by substituting 656 for 655; K656 for K655; K676 for K675; 756 for 755; 676 for 675; K676 for K675 and 776 for 775 in the part number.
- N14. Rated for both 25kV and 35kV applications.
- N15. 600ATM assembly tool required for Window-Op assembly.

Refer to the **W** and **X** tables on pages 32 and 33 for sizing to cable insulation diameter and conductor size.

For cable shield adapters and jacket seals, see page 28.



SEPARABLE CONNECTORS CABLE JOINTS

600 SERIES DEADBREAK

600 Series Separable Cable Joints are available in 2, 3 and 4-way versions and include a capacitive test point as standard. Units are interchangeable, featuring bolted connections. Designs are compact and ideally suited for small vaults and manholes.

DE-ENERGIZED joints can be quickly and easily connected and disconnected using standard hand tools and equipment in accordance with accepted operating practices. Bus bars can be changed to add or remove cables from the joint. Optional accessories include insulating and grounding caps and plugs which allow visible external separation, by-pass, isolation, dead-ending, grounding and testing.

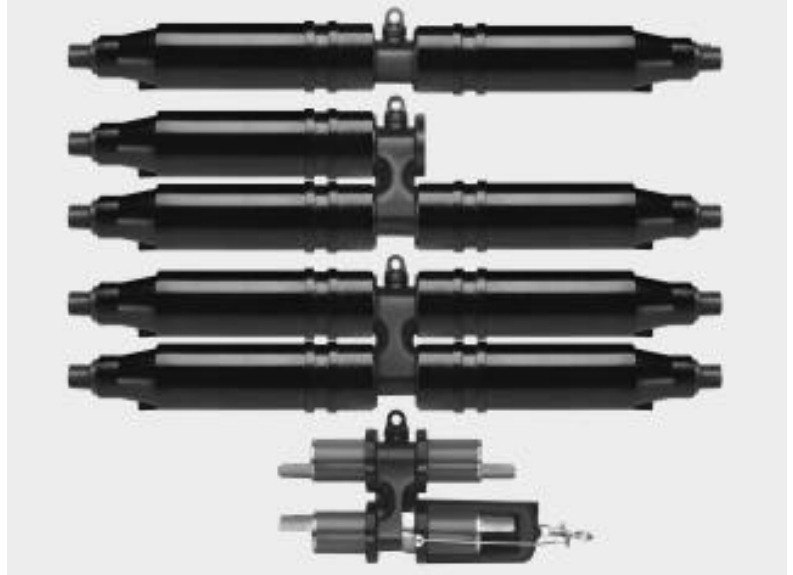

RATINGS OVERVIEW

See page 2 for complete information

CURRENT RATINGS

(Prefixes: 650, K650, K655, K656 & 03700)

600 Amp Continuous
25kA sym., 10 cycles

(Prefixes: 675, K675, K676 & 03702)

900 Amp Continuous
25kA sym., 10 cycles

NOTE: 900 Amp ratings require copper cable and copper current-carrying components.

VOLTAGE RATINGS

15/25kV Class (5kV thru 28kV)

16.2kV Phase-to-Ground

28kV Phase-to-Phase

140kV BIL

45kV AC Withstand

84kV DC Withstand

21.5kV Corona Extinction

Note: Elastimold has increased the IEEE Standard Production and Design Test levels for 25kV Class products to include 27kV and 28kV systems.

SEPARABLE CABLE JOINTS – 600 SERIES DEADBREAK

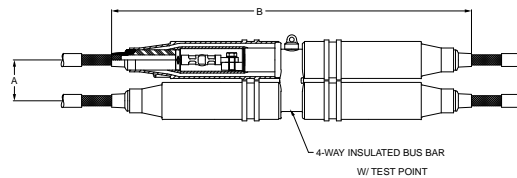

SEPARABLE
H-JOINT
(4-WAY)

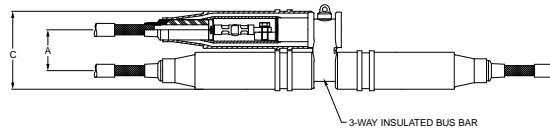

SEPARABLE
WYE-JOINT
(3-WAY)

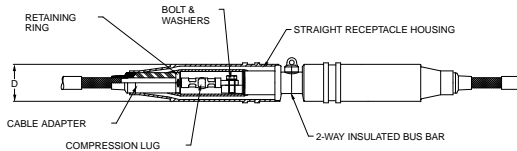

SEPARABLE
STRAIGHT JOINT
(2-WAY)

OPERATING ACCESSORIES

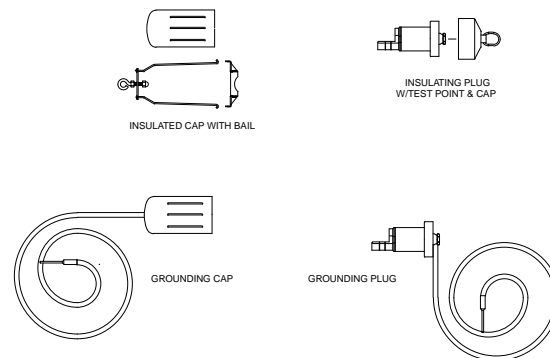

Note: The separable cable joints shown here use a special "Y" interface that may not be interchangeable with other 600 Series interfaces.

DIMENSION	INCHES
A	4 1/4
B	37 1/8
C	8 1/8
D	3 7/8

DEADFRONT	SEPARABLE CONNECTORS	200 AMP LOADBREAK	5-15kV
LIVEFRONT	FUSED ELBOWS	200 AMP DEADBREAK	25kV
	CABLE JOINTS	600 SERIES DEADBREAK	35kV
	TERMINATIONS		
	SURGE ARRESTERS		

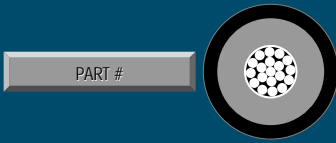

Part numbers that contain the letters **W** or **X** are size sensitive. To complete the part number, refer to the **W** or **X** tables indicated.

600 SERIES DEADBREAK

Illustration (not to scale)	Description	Voltage Class	ELASTIMOLD Part Number	Notes
	Separable Straight Joint Pkg. (2-way) w/ Test Point	15/25kV	K6561-W0X Use Tables W7 and X6	N1,6,8
	Basic Housing Pkg. Straight Joint w/ Test Point	15/25kV	K6561-HP	N2,6
	Separable Wye Joint Pkg. (3-Way) w/ Test Point	15/25kV	K656CY-W0X Use Tables W7 and X6	N1,6,8
	Basic Housing Pkg. Wye Joint w/ Test point	15/25kV	K656CY-HP	N2,6
	Separable "H" Joint Pkg. (4-Way) w/ Test Point	15/25kV	K656CH-W0X Use Tables W7 and X6	N1,6,8
	Basic Housing Pkg. "H" Joint w/ Test Point	15/25kV	K656CH-HP	N2,6
	2-Way Insulated Bus Bar w/Test Point	15/25kV	K6561-BUS	N3,6
	3-Way Insulated Bus Bar w/Test Point	15/25kV	K656CY-BUS	N3,6
	4-Way Insulated Bus Bar w/Test Point	15/25kV	K656CH-BUS	N3,6
	Straight Receptacle	15/25kV	K655YSR-W0X Use Tables W7 and X6	N4,6,8
	Straight Receptacle Housing Only	15/25kV	K655YBSR	N5,6,10
	Insulated Cap w/ Bail	15/25kV	K655YDR	
	Bail Only	15/25kV	650BA	
	Cable Adapter	15/25kV	655CA-W Use Table W7	
	Adapter Retaining Ring	15/25kV	650ARR-X Use Table X6	
	Compression Lug	15/25kV 15/25kV	03700X 03702X Use Table X6	N6,7 N6,9
	600 Series Straight Receptacle Size Sensitive Kit (Cable Adapter, Retaining Ring & Lug)	15/25kV	655CK-W0X Use Tables W7 and X6	N8
	Assembly/ Disassembly Tool	15/25kV	600YADT	

Illustration (not to scale)	Description	Voltage Class	ELASTIMOLD Part Number	Notes
	Insulating Plug w/ Test Point & Cap	15/25kV	K650YBIP	
	Grounding Plug (4/0 AWG x 6' Ground Lead)	15/25kV	650YGP	
	Grounding Cap (4/0 AWG x 6' Ground Lead)	15/25kV	650YGDR	
	Aluminum Bolt & Washers	15/25kV	650BAW	N6
	Brass Bolt & Washers	15/25kV	675BAW	N6

- N1. Complete Joint Packages consisting of: insulated bus bar; straight receptacle housings, retaining rings, cable size adapters, lugs, bolts and washers.
- N2. Housing Packages consisting of the following non-size sensitive components of the joint: insulated bus bar, straight receptacle housings, bolts and washers.
- N3. Insulated bus bar only.
- N4. Straight Receptacle consisting of: straight receptacle housing, retaining ring, cable adapter, lug, bolt and washers.
- N5. Straight receptacle housing consisting of: straight receptacle housing, bolt and washers.
- N6. For 900 Amp ratings, substitute 675 for 650 and 655; 676 for 656; K675 for K650 and K655; K676 for K656; 775 for 750 and 755; 776 for 756 and 2X for 0X in the part number. The 900 Amp rating requires copper current-carrying connector components and copper conductor cable.
- N7. Aluminum lug for use on aluminum or copper conductors. DO NOT substitute threaded 03600X lug.
- N8. Add suffix symbol from page 29 to include cable shield grounding kit and/or cable jacket sealing kit.
- N9. Copper lug for use with COPPER CONDUCTOR ONLY. DO NOT substitute threaded 03602X lug.
- N10. Available without the bolt & washers by adding "N" to the part number.

Refer to the **W** and **X** tables on pages 32 and 33 for sizing to cable insulation diameter and conductor size.
For cable shield adapters and jacket seals, see page 28.



PCJ CABLE JOINTS

PCJ™ Power Cable Joints utilize permanently crimped connectors. PCJ Housings are fully insulated, shielded and sealed for direct buried, vault, submersible and other severe service applications. Units have been designed and tested per IEEE Standard 404 to assure system matched performance and ratings equal to the cable to which the splice will be installed.

PCJ Power Cable Joints are available in 2 styles:

Style 1 uses a single piece housing that is sized to accommodate a specific range of cable. Style 1 units are ideally suited for straight splicing of the same or similar cable.

Style 2 designs incorporate a universal housing with separate cable adapters to allow transition splices of different types and sizes of cable.



ELECTRICAL RATINGS SUMMARY

The follow ratings summary is based on **IEEE Std. 404** and applies to all Elastimold PCJ Power Cable Joints.

VOLTAGE

- A. 15kV Class (8.7kV Phase-to-Ground)
- B. 25kV Class (14.4kV Phase-to-Ground)
- C. 35kV Class (20.2kV Phase-to-Ground)

- **Impulse Withstand:** A= 110kV, B= 150kV, C= 200kV BIL, 1.2 x 50 microsecond wave.
- **Corona Extinction Voltage:** A= 13kV, B= 22kV, C= 31kV minimum, 3pC sensitivity.
- **DC Withstand:** During installation: A= 56kV, B= 80kV, C= 100kV (Reference AEIC CS5 and CS6, Section L.1.)
- **DC Withstand:**
After installation and in service for the first 5 years:
A= 18kV, B= 25kV, C= 31kV for XLPE Insulated Cables
and A= 45kV, B= 64kV, C= 80kV for EPR Insulated Cables.
(Reference AEIC CS5 and CS6, Section L.2.)

CURRENT

- Continuous rating equal to the rating of the cable.
- Short-Time rating equal to the rating of the cable.

SHIELD DESIGN

- Meets IEEE standard 592 for Exposed Semiconducting Shields on Premolded High Voltage Cable Joints and Separable Insulated Connectors.

Production tests include 100% tests of the premolded joints to assure:

- **Corona Extinction Voltage:** A= 13kV, B= 22kV, C= 31kV minimum, 3pC sensitivity.
- **AC Withstand:** A= 35kV, B= 52kV, C= 69kV, 60 Hz, 1 minute.

Design tests on production joints demonstrate compliance with IEEE 404 including:

- **Corona Extinction Voltage:** A= 13.0kV, B= 21.6kV, C= 30.3kV minimum, 3pC sensitivity.
- **AC Withstand:** A= 35kV, B= 52kV, C= 69kV, 60 Hz 1 minute.
- **DC Withstand:** A= 70kV, B= 100kV, C= 125kV negative polarity, 15 minutes.
- **Impulse Withstand (BIL):** A= 110kV, B= 150kV, C= 200kV, 10 positive and 10 negative, 1.2 x 50 microsecond wave, at conductor temperatures of 20° and 130°C, nominal.
- **Short-Time Current:** magnitude equal to cable.
- **Cyclic Aging:** 30 days at: A= 26.1kV, B= 43.2kV, C= 60.2kV AC continuous, load current for 8 hours per day providing 130° conductor temperature. Joints then subjected to: A= 35kV, B= 52kV, C= 69kV for 5 hours followed by: A= 53kV, B= 78kV, C= 104kV for 1 hour.
- **Load Cycle:** Connectors meet thermal and mechanical requirements of ANSI C119.4, Class A heat cycle, Class 2 partial tension.

DEADFRONT	SEPARABLE CONNECTORS	200 AMP LOADBREAK	5-15kV	PART #
LIVEFRONT	FUSED ELBOWS	200 AMP DEADBREAK	25kV	
	CABLE JOINTS	600 SERIES DEADBREAK	35kV	
	TERMINATIONS			
	SURGE ARRESTERS			

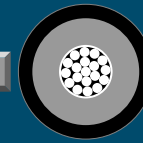

Part numbers that contain the letters W or X are size sensitive. To complete the part number, refer to the W or X tables indicated.

PCJ Style 1 with single-piece housing

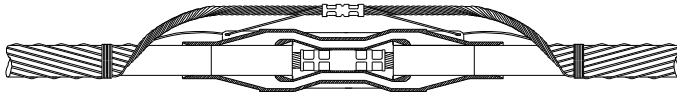

PCJ Style 2 with universal housing and separate cable adapters that can be varied with the cable application.

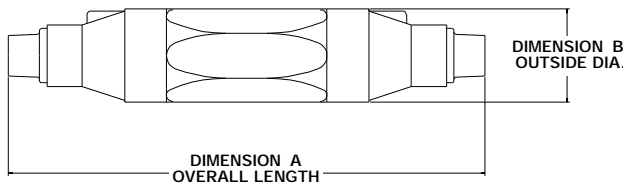
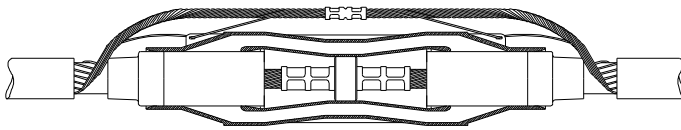

ORDERING INFORMATION

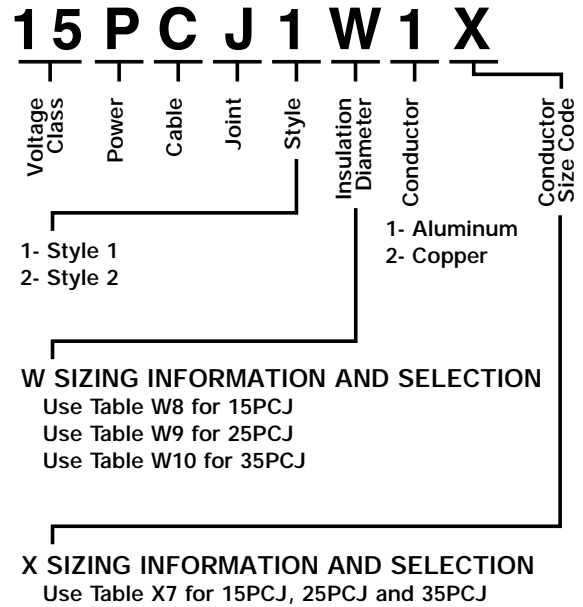

DIMENSIONAL DATA

STYLE 1 PART NUMBER	A	B
	inches	inches
15PCJ1FX	10 1/4"	1 3/4"
15PCJ1GX	10 1/4"	1 3/4"
25PCJ1GX	14 3/8"	2 7/16"
15/25/35PCJ1HX	14 3/8"	2 7/16"
15/25/35PCJ1JX	14 3/8"	2 7/16"
15/25/35PCJ1KX	14 3/8"	2 25/32"
15/25/35PCJ1LX	14 3/8"	2 25/32"
15/25/35PCJ1LMX	14 3/8"	2 25/32"
15/25/35PCJ1MX	14 3/8"	2 25/32"
15/25/35PCJ1NX	15 3/4"	3 3/16"
15/25/35PCJ1PX	15 3/4"	3 3/16"
15/25/35PCJ1QX	15 3/4"	3 3/16"

STYLE 2 PART NUMBER	A	B
	inches	inches
15PCJ2EX	16 3/8"	2 25/32"
15PCJ2FX	16 3/8"	2 25/32"
15/25PCJ2GX	16 3/8"	2 25/32"
15/25/35PCJ2HX	16 3/8"	2 25/32"
15/25/35PCJ2JX	16 3/8"	2 25/32"
15/25/35PCJ2KX	21"	3 3/4"
15/25/35PCJ2LX	21"	3 3/4"
15/25/35PCJ2MX	21"	3 3/4"
15/25/35PCJ2NX	21"	3 3/4"
15/25/35PCJ2PX	21"	3 3/4"
15/25/35PCJ2QX	21"	3 3/4"

Description	Voltage Class	ELASTIMOLD Part Number	Notes
Power Cable Joint Style 1	15kV	15PCJ1W1X	N1
	15kV	15PCJ1W2X	N2
	25kV	25PCJ1W1X	N1
	25kV	25PCJ1W2X	N2
	35kV	35PCJ1W1X	N1
	35kV	35PCJ1W2X	N2
Power Cable Joint Style 2	15kV	15PCJ2W1X	N1
	15kV	15PCJ2W2X	N2
	25kV	25PCJ2W1X	N1
	25kV	25PCJ2W2X	N2
	35kV	35PCJ2W1X	N1
	35kV	35PCJ2W2X	N2

- Kit includes aluminum compression connector suitable for splicing aluminum conductor to aluminum conductor or aluminum conductor to copper conductor.
- Kit includes copper compression connector suitable for splicing copper conductor to copper conductor only.

Refer to the W and X tables on pages 32 and 33 for sizing to cable insulation diameter and conductor size.

For cable shield adapters and jacket seals, see page 28.



CABLE TERMINATIONS

Elastimold cable terminations are available in single piece or modular designs. Terminators allow connection and transition from shielded, underground cable to bare overhead conductors and live-front equipment. Units are designed and rated per IEEE Standard 48 for riser pole, padmount, indoor and outdoor applications. PCT1, PCT2, 16THG and 35MTG terminators provide sufficient creep, strike and weather sealing for class 1 outdoor service. PCT1 and PCT2 also include an integral cable jacket seal. The 35MTGI terminators and 35MSC stress cones are rated for class 2 and class 3 indoor service respectively. Optional mounting brackets, aerial lugs and equipment connectors are available as required.



ELECTRICAL RATINGS SUMMARY

The following ratings summary is based on IEEE Std. 48 and applies to all the terminations on page 22 thru 25. Elastimold terminations are designed for use on three-phase systems, either 3-wire or 4-wire and the single-phase laterals of these systems.

VOLTAGE RATINGS

15kV Class

9.5kV Phase-to-Ground
 110kV BIL 1.2 x 50 microsecond wave
 AC Withstand:
 50kV 1 min. – dry
 35kV 6 hr. – dry
 45kV 10 sec. – wet
 13kV Corona Extinction

25kV Class

16kV Phase-to-Ground
 150kV BIL 1.2 x 50 microsecond wave
 AC Withstand:
 65kV 1 min. – dry
 55kV 6 hr. – dry
 60kV 10 sec. – wet
 21.5kV Corona Extinction

35kV Class

22kV Phase-to-Ground
 200kV BIL 1.2 x 50 microsecond wave
 AC Withstand:
 90kV 1 min. – dry
 75kV 6 hr. – dry
 80kV 10 sec. – wet
 30kV Corona Extinction

TERMINATIONS

SINGLE PIECE TERMINATORS

STRESS CONE

MODULAR TERMINATORS

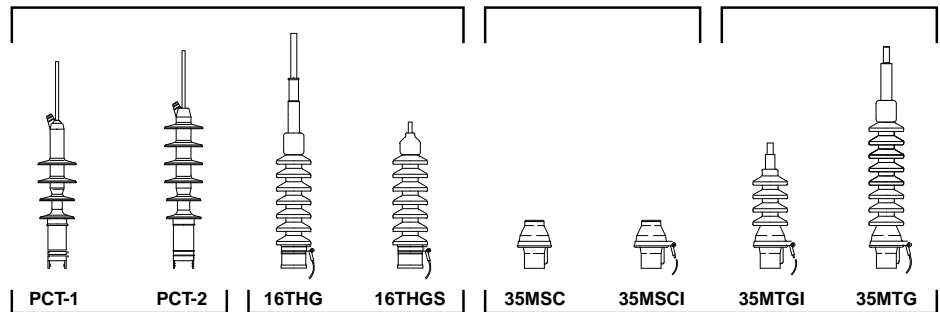

BRACKETS

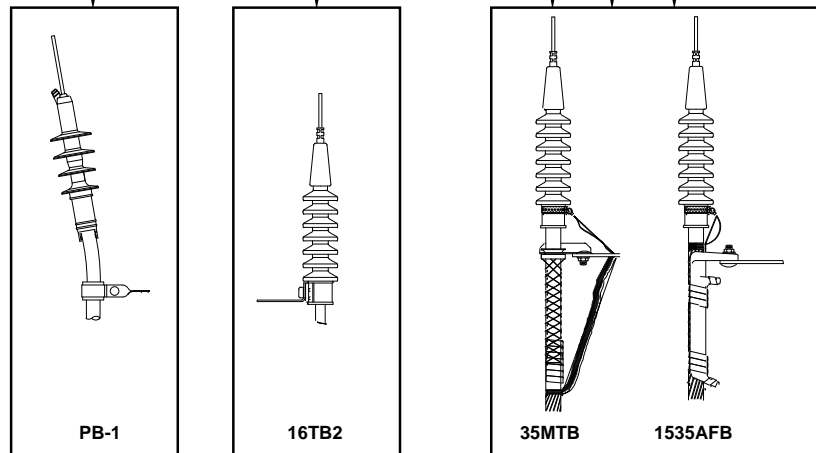

	SEPARABLE CONNECTORS		
DEADFRONT	FUSED ELBOWS	200 AMP LOADBREAK	5-15kV
LIVEFRONT	CABLE JOINTS	200 AMP DEADBREAK	25kV
	TERMINATIONS	600 SERIES DEADBREAK	35kV
	SURGE ARRESTERS		

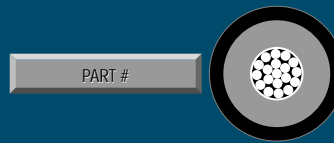

Part numbers that contain the letters W or X are size sensitive. To complete the part number, refer to the W or X tables indicated.

TERMINATIONS

Illustration (not to scale)	Description	Voltage Class	ELASTIMOLD Part Number	Notes
	Single-Piece Terminator (Class 1)	15kV 25kV	PCT1-X-4 Use Table X9 PCT2-X-4 Use Table X9	N12,14, 15, 22 N12,14, 15, 23
	Housing only	15kV 25kV	PCT1-4 PCT2-4	N13, 22 N13, 23
	Single-Piece Terminator (Class 1)	15/25kV	16THG-WX-4 Use Tables W12 and X8	N2,14 15
	Housing only	15/25kV	16THGH-W Use Table W12	
	Single-Piece Terminator for solid conductor only (Class 1)	15/25kV	16THGS-WX Use Tables W12 and X4	N3
	Stress Cone (Class 3)	ALL	35MSC-W Use Table W11	N17
	w/Grd. Strap	ALL	35MSCI-W Use Table W11	N17
	Modules only	ALL	35MG-W Use Table W13	N11,16
	Modular Terminator (Class 1)	15kV	35MTG-WX-4-CA Use Tables W13 and X3	N2,11
		25kV	35MTG-WX-8-CA Use Tables W13 and X3	N2,5,11
		35kV	35MTG-WX-10-CA Use Tables W13 and X3	N2,6,11
	Modular Terminator (Class 2) w/o Rain Cap	15kV	35MTGI-W-4 Use Table W13	N11
		25kV	35MTGI-W-6 Use Table W13	N11
		35kV	35MTGI-W-8 Use Table W13	N7,11
	Rod Contact for PCT	15/25kV	0070X Use Table X9	N1
	Rod Contact for 16THG	15/25kV	16TCA-X Use Table X8	N2, 8
	Solid Conductor Package for 16THGS	15/25kV	16CAS-X Use Table X4	N3, 9
	3/4"-16 Threaded Rod for MTG	ALL	35MTGA-WX-1 Use Tables W13 and X3	N2,10,11 18, 25
	1"-14 Threaded Rod for MTG	ALL	35MTGA-WX-2 Use Tables W13 and X3	N2,10,11 19, 25
	Two-Hole Spade for MTG	ALL	35MTGA-WX-3 Use Tables W13 and X3	N4,10,11 20, 25
	Two-Hole Spade for PCT	ALL	0100X Use Table X9	N1
	One-Hole Spade for PCT	ALL	0110X Use Table X9	N1
	Universal Rod for MTG	ALL	35MTCGA-WX-4 Use Tables W13 and X3	N2,10,11 21, 25
	Aerial Lugs for MTG Threaded Rod (Two-hole spade or bare wire)	ALL	35AL-A	N10, 24

- N1. Use with PCT1 or PCT2 Terminators.
- N2. Includes contact rod, ground strap and rain cap.
- N3. Includes crimp ring, ground strap and rain cap.
- N4. Includes spade contact, ground strap and rain cap.
- N5. For KA thru PB sizes use 35MTG-WX-6-CA.
- N6. For KA thru PB sizes use 35MTG-WX-8-CA.
- N7. For KA thru PB sizes use 35MTGI-W-6.
- N8. Use with 16THG Terminators.
- N9. Use with 16THGS Terminators.
- N10. Use with 35MTG Terminators.
- N11. Refer to page 24 for detailed ordering instructions.
- N12. Includes rod contact as standard. Specify suffix "-3" in place of "-4" for two-hole spade lug. Specify suffix "-5" in place of "-4" for one-hole spade lug.
- N13. Specify suffix "-3" or "-5" in place of "-4" for two-hole spade lug housing or one-hole spade style housing.
- N14. Use 1X for rod contact for aluminum conductors only.
- N15. Use 0X for rod contact for aluminum or copper conductors.
- N16. Available in sizes from GA thru PB.
- N17. Available in sizes EB thru PB.
- N18. For conductors from 1/0 thru 350 kcmil.
- N19. For conductors from 400 kcmil thru 1000 kcmil.
- N20. For conductors from #2 to 1000 kcmil.
- N21. For conductors from #6 thru 4/0.
- N22. Use for insulation dia. range from .640" thru 1.070".
- N23. Use for insulation dia. range from .830" thru 1.180".
- N24. Select symbol for "A" from aerial lug ordering information on page 24.
- N25. W13 Table provides sizing for rain cap
X10 Table provides sizing for connectors.

Refer to the **W** and **X** tables on pages 32 and 33 for sizing to cable insulation diameter and conductor size.
For cable shield adapters and jacket seals, see page 28.



CABLE TERMINATIONS cont'd

ORDERING INSTRUCTIONS FOR MODULAR TERMINATORS

35MTG - W X - N - C A

I = Indoor
Blank = Outdoor

Use Table W13, below

Use Table X3, below

NOTE: Sizes are limited depending upon connector style selection. See notes 8 thru 11 on page 25.

Recommended Number of Modules

	GA-JB	KA-PB
15kV	4	4
25kV	8	6
35kV	10	8

Connector Style

Description	Available for Conductor Sizes	Symbol	Note
3/4"-16 Threaded Rod	1/0 thru 350 kcmil	-1	N8
1"-14 Threaded Rod	400 thru 1000 kcmil	-2	N9
2-Hole Spade	#2 thru 1000 kcmil	-3	N10
Universal Rod	#6 thru 4/0	-4	N11

Aerial Lugs for Threaded Rod Connectors Only

Type	Connector	Symbol
Bare Wire	3/4"-16 Rod	-11
2-Hole Spade	3/4"-16 Rod	-12
Bare Wire	1"-14 Rod	-21
2-Hole Spade	1"-14 Rod	-22

Table W13 USE FOR FOLLOWING PRODUCTS 35MTG 35MTGI	Cable Insulation Diameter in Inches		Symbol for W
	MIN.	MAX.	
	.775	.885	GA
	.825	.935	GAB
	.875	.985	GB
	.930	1.040	GH
	.980	1.115	HA
	1.040	1.175	HAB
	1.095	1.240	HB
	1.160	1.305	HJ
	1.220	1.375	JA
	1.285	1.395	JAB
	1.355	1.520	JB
	1.485	1.595	KA
	1.530	1.640	KAB
	1.575	1.685	KB
	1.665	1.785	PA
	1.755	1.875	PB

Table X3 USE FOR FOLLOWING PRODUCT 35MTG	Conductor SIZE AWG or kcmil	Symbol for X	
		Strand./ Compr.	Compt./ Solid.
	#6	3	-
	#5	3	-
	#4	2	3
	#3	2	-
	#2	1	2
	#1	0	1
	1/0	10	0
	2/0	20	10
	3/0	30	20
	4/0	40	30
	250	250	40
	300	300	250
	350	350	300
	400	400	350
	450	450	400
	500	500	450
	550	550	500
	600	600	500
	650-700	550	550
	750	750	600
	800	800	550
	900	900	750
	1000	1000	900

	SEPARABLE CONNECTORS		
DEADFRONT	FUSED ELBOWS	200 AMP LOADBREAK	5-15kV
LIVEFRONT	CABLE JOINTS	200 AMP DEADBREAK	25kV
	TERMINATIONS	600 SERIES DEADBREAK	35kV
	SURGE ARRESTERS		

PART #

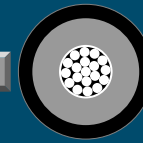

Part numbers that contain the letters **W** or **X** are size sensitive. To complete the part number, refer to the **W** or **X** tables indicated.

TERMINATIONS

Illustration (not to scale)	Description	Voltage Class	ELASTIMOLD Part Number	Notes
	PCT Positioning Bracket	ALL	PB-1	N1,12
	16THG Bracket	ALL	16TB-2	N6
	Bracket for crossarm mounting 16THG	ALL	16TB-3	N6
	Bracket for riser pole mounting 16THG	ALL	16TB-4	N6
	Bracket for tri-mounting 16THG	ALL	16TB-5	N6
	KELLUMS GRIP Bracket	ALL ALL ALL ALL	35MTB1-A 35MTB1-B 35MTB1-C 35MTB1-D	N1,2,6,7 N1,3,6,7 N1,4,6,7 N1,5,6,7
	KELLUMS Bracket for crossarm mounting	ALL ALL ALL ALL	35MTB3-A 35MTB3-B 35MTB3-C 35MTB3-D	N1,2,6,7 N1,3,6,7 N1,4,6,7 N1,5,6,7
	Bracket (for riser pole mounting)	ALL ALL ALL ALL	35MTB4-A 35MTB4-B 35MTB4-C 35MTB4-D	N1,2,6,7 N1,3,6,7 N1,4,6,7 N1,5,6,7
	KELLUMS Bracket for tri-mounting	ALL ALL ALL ALL	35MTB5-A 35MTB5-B 35MTB5-C 35MTB5-D	N1,2,6,7 N1,3,6,7 N1,4,6,7 N1,5,6,7
	ALUMA FORM Bracket	ALL	1535AFB-1	N1,6,7
	ALUMA FORM Bracket for Crossarm mounting	ALL	1535AFB-3	N1,6,7
	ALUMA FORM Bracket for riser-pole mounting	ALL	1535AFB-4	N1,6,7
	ALUMA FORM Bracket for tri-mounting	ALL	1535AFB-5	N1,6,7

- N1. Use with PCT-1 or PCT-2 Terminators.
- N2. Fits overall cable O.D. from 1.195" to 1.625".
- N3. Fits overall cable O.D. from .925" to 1.335".
- N4. Fits overall cable O.D. from .890" to 1.185".
- N5. Fits overall cable O.D. from 1.500" to 2.000".
- N6. Use with 16THG & 16THGS Terminators.
- N7. Use with MTG, MTG1 & MSC Terminators.
- N8. For conductors from 1/0 thru 350 kcmil.
- N9. For conductors from 400 kcmil thru 1000 kcmil.
- N10. For conductors from #2 to 1000 kcmil.
- N11. For conductors from #6 thru 4/0.
- N12. Fits overall cable O.D. from .750" to 1.625"

Refer to the **W** and **X** tables on pages 32 and 33 for sizing to cable insulation diameter and conductor size.

For cable shield adapters and jacket seals, see page 28.

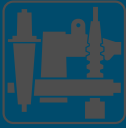

SURGE ARRESTERS

ELASTIMOLD Metal Oxide Varistor (MOV) surge arresters are fully-shielded, fully-submersible and are equipped with IEEE 386 interfaces for convenient energized connection with other 200 Amp loadbreak components. Units are compact, allowing installation in existing cabinetry. For application ease, arresters are available in 3 styles: Elbow (ESA), Parking Stand (PSA) and Bushing (BSA). The PSA and BSA arresters permit direct connection eliminating the need for additional accessories.

Elastimold arresters provide high voltage lightning and switching surge protection of transformers, cable, equipment and other components typically located on underground power distribution systems. Proper placement, voltage selection and coordination with riser pole arresters minimizes damaging surge voltages by improving protective margins.

Typical applications include installing an arrester at the end of a radial system or at both ends of an open point on a loop system. Additional arresters can be added at strategic locations upstream from the end point for optimum protection. Request Form 2068 (Surge Protection Options For Underground Distribution) and Form 2069 (Arrester Applications – Underground Electrical Systems) for additional application and margin of protection information.

ESA Elbow Arresters are also available with a 200 Amp Deadbreak interface for mating with other Deadbreak accessories.

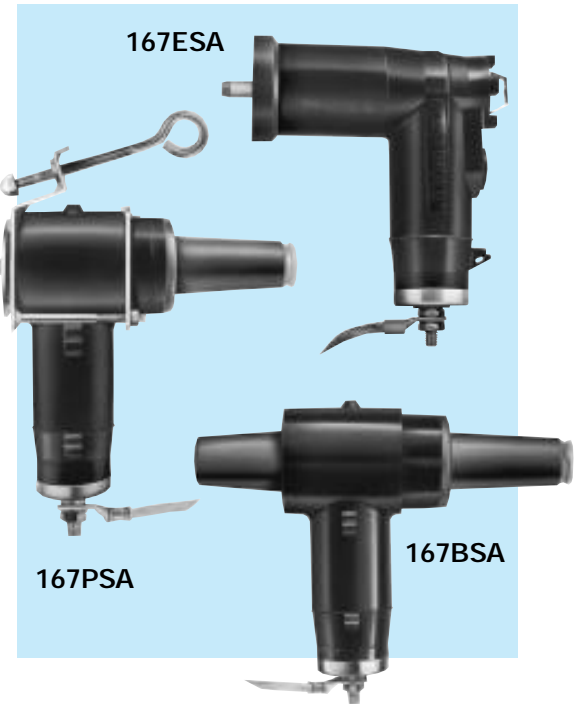

ELECTRICAL RATINGS & PROTECTIVE CHARACTERISTICS

Performance:

High Current Short Duration - All MOV Arresters withstand two discharges of 40kA crest.
 Low Current Long Duration - All MOV Arresters withstand 20 surges of 75 amperes/2000 microsecond duration.

Duty Cycle Test - All MOV Arresters withstand 22 operations of 5kA crest at 8 x 20 microsecond duration while energized at rated voltage for the initial 20 operations and at maximum continuous operating voltage (MCOV) for the final two operations.

Following each of the preceding tests, MOV Arresters demonstrate thermal recovery at MCOV.

PROTECTIVE CHARACTERISTICS:

	MCOV (kVrms) Note 1	Duty Cycle Rating (kVrms)	Maximum Discharge Voltage (kV crest) 8x20 microsecond current wave					F.O.W. Protective Level (kV crest) Note 2
			1.5kA	3kA	5kA	10kA	20kA	
15kV CLASS	2.55	3	10.5	11.0	11.5	13.0	14.5	13.0
	5.1	6	20.5	21.5	23.0	25.5	30.0	25.5
	8.4	10	30.5	32.5	34.5	38.5	43.5	38.5
	10.2	12	40.0	42.5	45.0	50.0	56.5	50.0
	12.7	15	48.0	51.0	54.0	60.0	68.0	60.0
	15.3	18	56.5	60.0	64.0	71.0	80.5	71.0
25kV CLASS	8.4	10	30.5	32.5	34.5	38.5	43.5	38.5
	10.2	12	40.0	42.5	45.0	50.0	56.5	50.0
	12.7	15	48.0	51.0	54.0	60.0	68.0	60.0
	15.3	18	56.5	60.0	64.0	71.0	80.5	71.0
	17.0	21	65.5	69.5	74.0	82.5	93.0	82.5
35kV CLASS	19.5	24	78.5	83.5	89.0	99.0	112.0	99.0
	22.0	27	87.5	93.0	99.0	110.0	124.5	110.0
	24.4	30	95.5	101.5	108.0	120.0	136.0	120.0

NOTES:

1. MCOV = Maximum Continuous Operating Voltage.
2. The front of wave (FOW) protective level is the maximum discharge for a 5kA impulse current wave producing a voltage wave cresting in 0.5 microseconds.

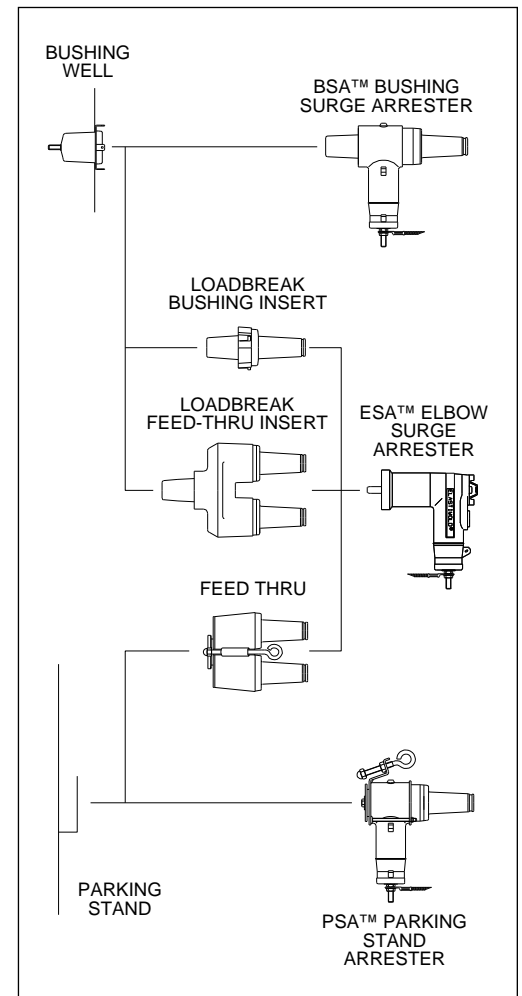

DEADFRONT	SEPARABLE CONNECTORS	200 AMP LOADBREAK	5-15kV
LIVEFRONT	FUSED ELBOWS	200 AMP DEADBREAK	25kV
	CABLE JOINTS	600 SERIES DEADBREAK	35kV
	TERMINATIONS		
	SURGE ARRESTERS		

SELECTION CHART

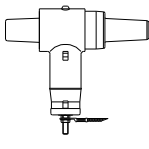
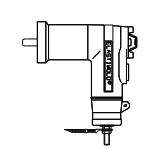
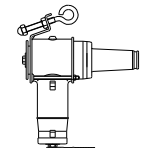
Illustration (not to scale)	Description	Voltage Class	Elastimold Part Number	MCOV kVrms
	BSA Surge Arrester (includes assembly tool)	15kV	167BSA-3	2.55
		15kV	167BSA-6	5.10
		15kV	167BSA-10	8.40
		15kV	167BSA-12	10.20
		15kV	167BSA-15	12.70
	See Notes N1, 2, 3, 4	15kV	167BSA-18	15.30
		25kV	273BSA-10	8.40
		25kV	273BSA-12	10.20
		25kV	273BSA-15	12.70
		25kV	273BSA-18	15.30
		25kV	273BSA-21	17.00
		35kV	375BSA-24	19.50
		35kV	375BSA-27	22.00
		35kV	375BSA-30	24.40
	ESA Elbow Surge Arrester	15kV	167ESA-3	2.55
		15kV	167ESA-6	5.10
		15kV	167ESA-10	8.40
		15kV	167ESA-12	10.20
		15kV	167ESA-15	12.70
	See Notes N2, 3, 5	15kV	167ESA-18	15.30
		25kV	273ESA-10	8.40
		25kV	273ESA-12	10.20
		25kV	273ESA-15	12.70
		25kV	273ESA-18	15.30
		25kV	273ESA-21	17.00
		35kV	375ESA-24	19.50
		35kV	375ESA-27	22.00
		35kV	375ESA-30	24.40
	PSA Parking Stand Arrester	15kV	167PSA-3	2.55
		15kV	167PSA-6	5.10
		15kV	167PSA-10	8.40
		15kV	167PSA-12	10.20
		15kV	167PSA-15	12.70
	See Notes N1, 2, 3	15kV	167PSA-18	15.30
		25kV	273PSA-10	8.40
		25kV	273PSA-12	10.20
		25kV	273PSA-15	12.70
		25kV	273PSA-18	15.30
		25kV	273PSA-21	17.00
		35kV	375PSA-24	19.50
		35kV	375PSA-27	22.00
		35kV	375PSA-30	24.40

ARRESTER APPLICATION TABLE

	System Line-to-Line Voltage kV rms		MCOV (Max. Continuous Operating Voltage) kV rms	
	Nominal	Max.	Solidly Grounded Neutral Circuits	3-Wire Ungrounded Circuits
15kV Class	2.40	2.54	2.55	2.55
	4.16	4.40	2.55	5.10
	4.80	5.08	5.10	5.10
	6.90	7.26	5.10	8.40
	8.32	8.80	5.10	8.40
	12.47	13.20	8.40	15.30
	13.20	13.97	8.40	15.30
	13.80	14.50	8.40*	15.30
	13.80	14.50	10.20	15.30
	25kV Class	6.90	7.26	5.10
8.32		8.80	5.10	8.40
12.47		13.20	8.40	15.30
13.20		13.97	8.40	15.30
13.80		14.50	8.40*	15.30
13.80		14.50	10.20	15.30
20.78		22.00	12.70	-
20.78		22.00	15.30*	-
23.00		24.34	15.30	-
24.94		26.40	15.30	-
24.94	26.40	17.00*	-	
28.00	29.80	17.00	-	
35kV Class	23.00	24.34	-	22.00
	34.50	36.51	22.00*	-
	34.50	36.51	24.40	-

* Preferred arrester MCOV for this system voltage

- N1. Elastimold PSA and BSA Arresters are equipped with a fully rated 200A switching and fault close loadbreak bushing.
- N2. Elastimold Arresters use high-strength silver epoxy bonded MOV blocks and shunted spring connections for the best circuit connection.
- N3. A 36 inch #4 AWG ground lead provided with each unit.
- N4. BSA installed by turning internal hex bolt (accessed thru the 200 Amp Bushing Interface) with 5/16" hex wrench supplied with each unit.
- N5. For 15kV and 25kV Class DEADBREAK system Elbow Arresters, use part number 156ESA with the appropriate Duty Cycle rating.

ORDERING INSTRUCTIONS:

- (1.) Determine the appropriate Maximum Continuous Operating Voltage (MCOV) for your system voltage by using the ELASTIMOLD ARRESTER APPLICATION TABLE.
- (2.) Specify the appropriate ELASTIMOLD part number from the selection chart.



SHIELD ADAPTERS, GROUNDING KITS AND JACKET SEALS

Elastimold elbows, splices and terminators are designed for application on XLP, EPR and other solid dielectric insulated power cables. As shown in the diagram below, a variety of shielding and jacketing methods are available for these types of cables. In some cases, the use of cable shield adapters, grounding kits and/or jacket seals are required in order to properly install Elastimold components. Refer to the diagram below for recommendations, selection and use of adapters, grounding kits and jacket seals.

CABLE ENTRANCE DETAIL

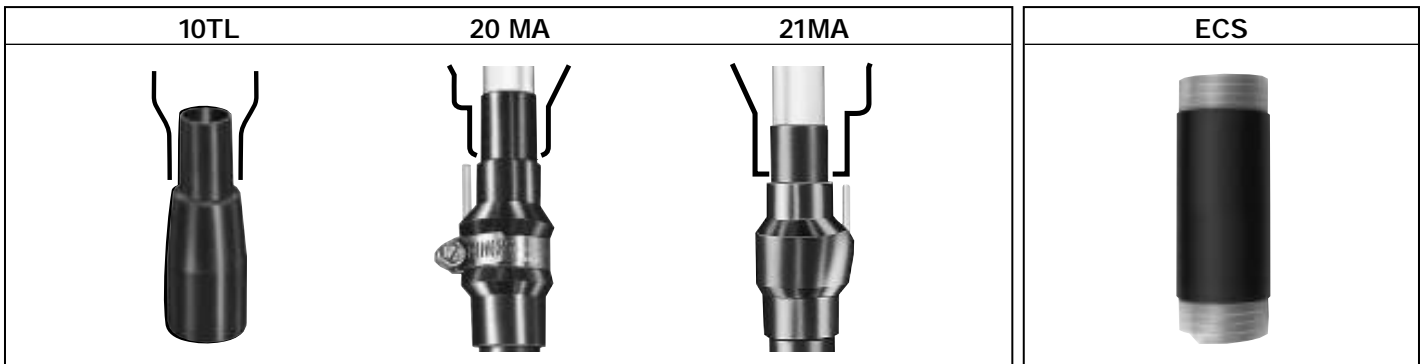
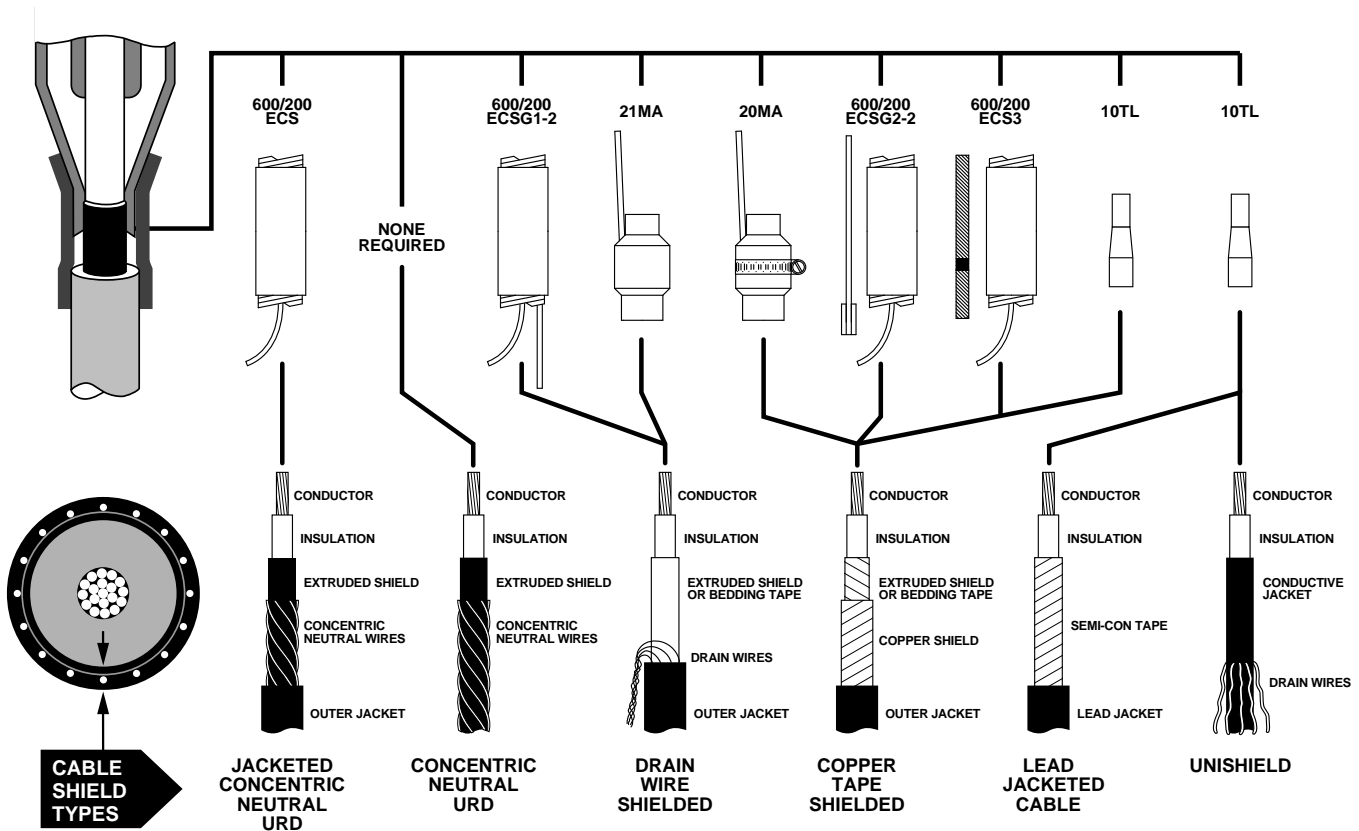
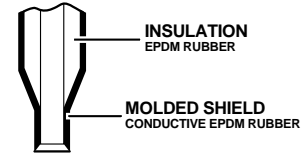

Cable Insulation Dia.	CABLE SHIELD ADAPTERS		
	10TL inches	20MA inches	21MA inches
min.	.495	.575	.575
max.	1.755	1.755	1.755

Jacket O.D.	JACKET SEALS	
	200ECS inches	600ECS inches
min.	.80	1.28
max.	1.50	2.30

	SEPARABLE CONNECTORS		
DEADFRONT	FUSED ELBOWS	200 AMP LOADBREAK	5-15kV
LIVEFRONT	CABLE JOINTS	200 AMP DEADBREAK	25kV
	TERMINATIONS	600 SERIES DEADBREAK	35kV
	SURGE ARRESTERS		

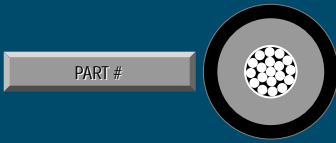

Part numbers that contain the letters W or X are size sensitive. To complete the part number, refer to the W or X tables indicated.

Illustration (not to scale)	Description	ELASTIMOLD Part Number	Suffix	Notes
	Cold Shrinkable Jacket Seal	200ECS	-S	N1,3
	Cold Shrinkable Jacket Seal	600ECS	-S	N1,4
	Metallic Tape Shield Adapter	20MA-W Use Table W14 for sizing	-0MA	N1,2
	Wire Shield Adapter	21MA-W Use Table W14 for sizing	-1MA	N1,2
	Shield Adapter	10TL-W Use Table W15 for sizing	-TL	N1,2
	Cold Shrinkable Seal w/ Copper Rod & Crimp Connector	200ECSG1-2	-SG1	N1,3
	Cold Shrinkable Seal w/ Copper Rod & Crimp Connector	600ECSG1-2	-SG1	N1,4
	Cold Shrinkable Seal w/ Copper Rod & Constant Force Spring	200ECSG2-2	-SG2	N1,3
	Cold Shrinkable Seal w/ Copper Rod & Constant Force Spring	600ECSG2-2	-SG2	N1,4
	Cold Shrinkable Seal w/ Copper Braid & Constant Force Spring	200ECSG3	-SG3	N1,3
	Cold Shrinkable Seal w/ Copper Braid & Constant Force Spring	600ECSG3	-SG3	N1,4

- N1. To order the kits as separate items, use the part numbers shown in the table. Example: To order a cold shrinkable tube as a separate item, use the part number 200ECS.
To order the kits as components of other items, add the suffix to the end of the part number. Example: To order a cold shrinkable jacket seal as a component of an elbow kit, use the part number 166LR-A520-S.
- N2. Only use this suffix with part numbers that designate a "W" housing size. Sizing the main component will also size the suffix adapter.
- N3. Size range .80" to 1.50" jacket diameters. Maximum installed diameter is approx. 2".
- N4. Size range 1.28" to 2.30" jacket diameters. Maximum installed diameter is approx. 2.75".

Table W14 USE FOR 20MA 21MA	Insulation Inches		Symbol for W
	MIN.	MAX.	
	.530	.680	E
.640	.820	F	
.760	.950	G	
.850	1.050	H	
.980	1.180	J	
1.090	1.310	K	
1.180	1.465	L	
1.280	1.430	LM	
1.370	1.630	M	
1.515	1.780	N	

Table W15 USE FOR 10TL	Insulation Inches		Symbol for W
	MIN.	MAX.	
	.495	.585	EB
.525	.635	EF	
.575	.585	FA	
.625	.735	FAB	
.675	.785	FB	
.725	.835	FG	
.775	.885	GA	
.825	.935	GAB	
.875	.985	GB	
.930	1.040	GH	
.980	1.115	HA	
1.040	1.175	HAB	
1.095	1.240	HB	
1.160	1.305	HJ	
1.220	1.375	JA	
1.285	1.395	JAB	
1.355	1.520	JB	
1.485	1.595	KA	
1.530	1.640	KAB	
1.575	1.685	KB	
1.755	1.875	PB	



How to specify Size-Sensitive Products

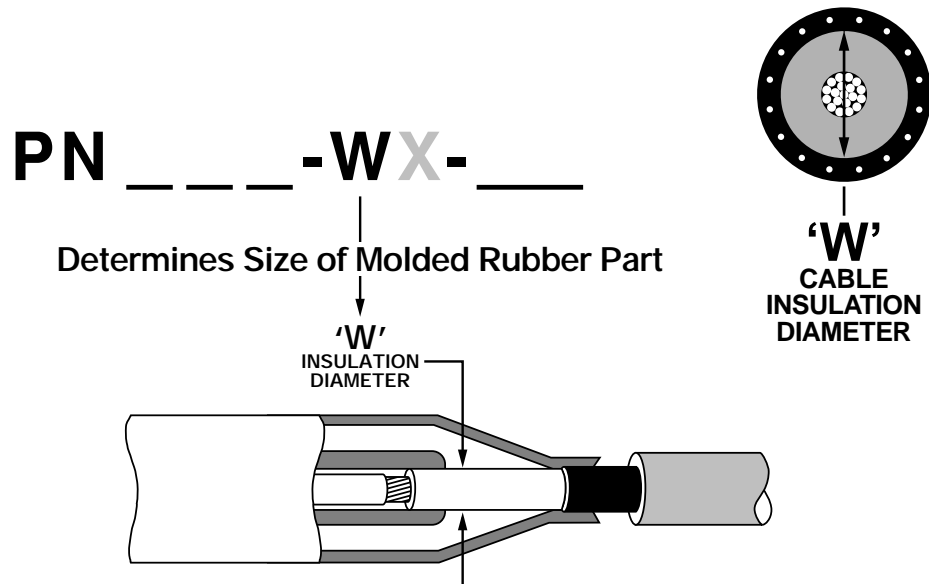

INSULATION DIAMETER SELECTION GUIDE

Elastimold Elbows, splices and terminations are designed for application on XLP, EPR and other solid dielectric insulated power cables. These components are constructed of molded elastomer and rely on an interference fit with the cable insulation diameter in order to maintain proper dielectric strength, creep path integrity and a water seal. Elastimold components are available in a wide range of sizes in order to accommodate a variety of cable insulation diameters.

Selection of size-sensitive components requires determining the cable insulation diameter. This can be done in several ways:

- Refer to the cable manufacturer's spec sheet for dimensions.
- Measure the cable.
- If the cable conforms to AEIC standards with a 175, 220, 260 or 345 mil wall thickness, use the table on page 34.

After the cable insulation diameter has been determined:

- Locate the W table indicated in the part number selection chart.
- Complete the ordering information by selecting and inserting the symbol (given in the W table) into the part number.

Ordering Example

To complete the information required to order a K655LR-W0X elbow for use on standard AEIC 500 kcmil stranded aluminum cable with .220 inch thick insulation wall.

- Determine that the insulation diameter (from AEIC table on page 34) is $1.325 \pm .030$ inches.
- For this elbow, the part number selection chart on page 11 indicates to use table W7 for elbow sizing and table X6 for connector sizing.
- From table W7 the symbol for W is L.
- From table X6 the symbol for X is 330.
- The completed part number therefore is K655LR-L0330.

	SEPARABLE CONNECTORS		
DEADFRONT	FUSED ELBOWS	200 AMP LOADBREAK	5-15kV
LIVEFRONT	CABLE JOINTS	200 AMP DEADBREAK	25kV
	TERMINATIONS	600 SERIES DEADBREAK	35kV
	SURGE ARRESTERS		

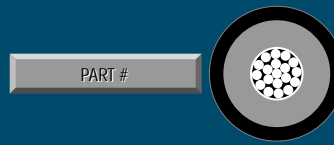

Part numbers that contain the letters W or X are size sensitive. To complete the part number, refer to the W or X tables indicated.

PN ____ -WX- ____

Determines Crimp Connector Size

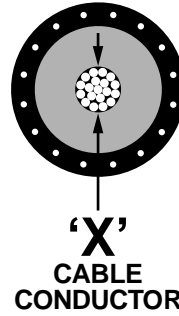
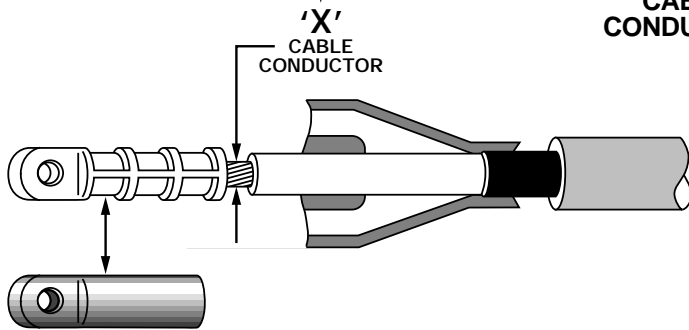

PN ____ -WX- ____

'Suffix'

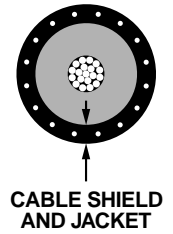

Determines Required Accessories (if any)

- Cable Shield Adaptors
- Cable Grounding Kits
- Cable Jacket Seal

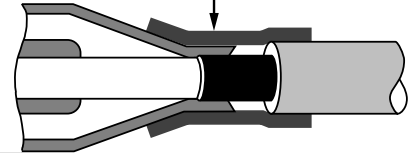

Reference Pages 28 & 29 for application, selection and ordering information.

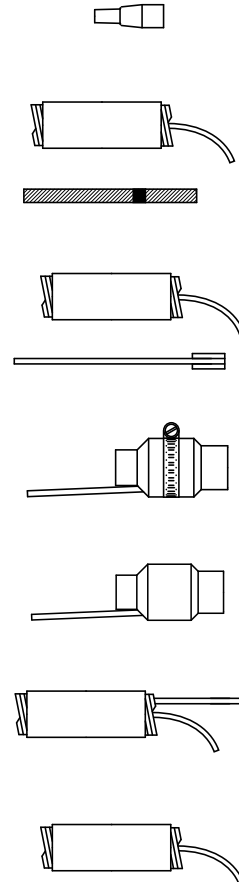

CONNECTOR SELECTION GUIDE

Elastimold elbows, splices and terminations are furnished with crimp style cable connectors. As standard, these connectors are constructed with a tin-plated aluminum barrel filled with an oxide inhibitor. Aluminum barrel connectors are designed for use on either aluminum or copper conductor cable.

When specified, all copper crimp style connectors can be furnished. These connectors are ONLY for use on copper conductor cable and are not for use with aluminum conductor cables.

Bi-metallic connectors are constructed with a copper top and an aluminum barrel. Bi-metal connectors can be used on either aluminum or copper conductor cable and are furnished as standard with 200 Amp Loadbreak Elbows, 200 Amp Deadbreak Elbows, and PCT, 16 THG or MTG terminations with rod connectors.

Selection and ordering the proper crimp connector requires determining information relative to the cable conductor as follows:

- Conductor size in AWG or kcmil
- Conductor type (stranded, compressed, compact or solid)
- Conductor material (aluminum or copper)

After the cable conductor information has been determined:

- Locate the X table indicated in the part number selection chart.
- Complete the ordering information by selecting and inserting the symbol (given in the X table) into the part number.

See the Ordering Example on page 30 for further information.



WX SIZE TABLES

“W”
INSULATION
DIAMETER

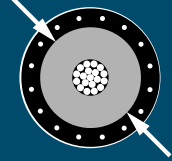

Table W1 USE FOR FOLLOWING PRODUCTS 165/166LR	Cable Insulation Diameter in Inches		Symbol for W
	MIN.	MAX.	
	.575	.740	A
	.665	.905	B
	.830	1.060	C
	.930	1.220	D

Table W2 USE FOR FOLLOWING PRODUCTS 273/274LR 273/274RLR	Cable Insulation Diameter in Inches		Symbol for W
	MIN.	MAX.	
	.760	.950	G
	.850	1.050	H
	.980	1.180	J
	1.090	1.310	K

Table W3 USE FOR FOLLOWING PRODUCTS 375/376LR	Cable Insulation Diameter in Inches		Symbol for W
	MIN.	MAX.	
	.850	1.050	H
	.980	1.180	J
	1.090	1.310	K
	1.235	1.465	L

Table W4 USE FOR FOLLOWING PRODUCTS 156LR 167/168RLR 167LRT	Cable Insulation Diameter in Inches		Symbol for W
	MIN.	MAX.	
	.640	.820	F
	.760	.950	G
	.850	1.050	H
	.980	1.180	J
	1.090	1.310	K

Table W5 USE FOR FOLLOWING PRODUCTS 167/168ELR 273/274ELR	Cable Insulation Diameter in Inches		Symbol for W
	MIN.	MAX.	
	.665	.895	6689
	.740	.950	7495
	.880	1.100	88110

Table W6 USE FOR FOLLOWING PRODUCTS K151SP K151SR K151LS K151LY 10EP 152EA 160CA* (*EB - FA Only)	Cable Insulation Diameter in Inches		Symbol for W
	MIN.	MAX.	
	.495	.585	EB
	.525	.635	EF
	.575	.685	FA
	.625	.735	FAB
	.675	.785	FB
	.725	.835	FG
	.775	.885	GA
	.825	.935	GAB
	.875	.985	GB

Table W7 USE FOR FOLLOWING PRODUCTS K656/1CY/CH K655/656LR K655/656SR 655/656LINK K655/656LINK 655/656ETP K655/656ETP 655/656LRTP K655/656LRTP 655/656BI-LINK K655/656BI-LINK 655CA 655CK 655TCK	Cable Insulation Diameter in Inches		Symbol for W
	MIN.	MAX.	
	.640	.820	F
	.760	.950	G
	.850	1.050	H
	.980	1.180	J
	1.090	1.310	K
	1.180	1.465	L
	1.280	1.430	LM
	1.370	1.630	M
	1.515	1.780	N
	1.725	1.935	P

Table W8 USE FOR FOLLOWING PRODUCTS 15PCJ-1 15PCJ-2	Cable Insulation Diameter in Inches		Symbol for W
	MIN.	MAX.	
	.640	.820	F
	.760	.950	G
	.850	1.050	H
	.980	1.180	J
	1.090	1.310	K
	1.180	1.465	L
	1.280	1.430	LM
	1.370	1.630	M
	1.515	1.780	N
	1.725	1.935	P
	1.900	2.120	Q

Table W9 USE FOR FOLLOWING PRODUCTS 25PCJ-1 25PCJ-2 755/756LR 755/756LINK 755/756ETP 755/756LRTP 755/756BI-LINK 755CA 755CK 755TCK	Cable Insulation Diameter in Inches		Symbol for W
	MIN.	MAX.	
	.760	.950	G
	.850	1.050	H
	.980	1.180	J
	1.090	1.310	K
	1.180	1.465	L
	1.280	1.430	LM
	1.370	1.630	M
	1.515	1.780	N
	1.725	1.935	P
	1.900	2.120	Q

Table W10 USE FOR FOLLOWING PRODUCTS 35PCJ-1 35PCJ-2	Cable Insulation Diameter in Inches		Symbol for W
	MIN.	MAX.	
	.850	1.050	H
	.980	1.180	J
	1.090	1.310	K
	1.180	1.465	L
	1.280	1.430	LM
	1.370	1.630	M
	1.515	1.780	N
	1.725	1.935	P
	1.900	2.120	Q

Table W11 USE FOR FOLLOWING PRODUCTS 35MSC 35MSCI	Cable Insulation Diameter in Inches		Symbol for W
	MIN.	MAX.	
	.495	.585	EB
	.525	.635	EF
	.575	.685	FA
	.625	.735	FAB
	.675	.785	FB
	.725	.835	FG
	.775	.885	GA
	.825	.935	GAB
	.875	.985	GB
	.930	1.040	GH
	.980	1.115	HA
	1.040	1.175	HAB
	1.095	1.240	HB
	1.160	1.305	HJ
	1.220	1.375	JA
	1.285	1.395	JAB
	1.355	1.520	JB
	1.485	1.595	KA
	1.530	1.640	KAB
	1.575	1.685	KB
	1.665	1.785	PA
	1.755	1.875	PB

Table W12 USE FOR FOLLOWING PRODUCTS 16THG 16THGS 16THGH	Cable Insulation Diameter in Inches		Symbol for W
	MIN.	MAX.	
	.495	.585	EB
	.525	.635	EF
	.575	.685	FA
	.625	.735	FAB
	.675	.785	FB
	.725	.835	FG
	.775	.885	GA
	.825	.935	GAB
	.875	.985	GB
	.930	1.040	GH
	.980	1.115	HA

Table W13 USE FOR FOLLOWING PRODUCTS 35MTG 35MTGI 35MTCGA	Cable Insulation Diameter in Inches		Symbol for W
	MIN.	MAX.	
	.775	.885	GA
	.825	.935	GAB
	.875	.985	GB
	.930	1.040	GH
	.980	1.115	HA
	1.040	1.175	HAB
	1.095	1.240	HB
	1.160	1.305	HJ
	1.220	1.375	JA
	1.285	1.395	JAB
	1.355	1.520	JB
	1.485	1.595	KA
	1.530	1.640	KAB
	1.575	1.685	KB
	1.665	1.785	PA
	1.755	1.875	PB

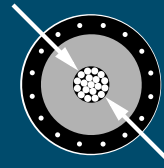

Table X1 USE FOR FOLLOWING PRODUCTS 167/168ELR 273/274ELR 156LR 165/166LR 273/274LR 167LRT 167/168RLR 273/274RLR 00400 02500 02509 02702 02800	Conductor Size AWG or kcmil	Symbol for X	
		Strand./ Compr.	Compt./ Solid.
	#4	5200	5190
	#3	5210	5200
	#2	5220	5210
	#1	5230	5220
	1/0	5240	5230
	2/0	5250	5240
	3/0	5260	5250
	4/0	5270	5260
	250	–	5270

Table X2 USE FOR FOLLOWING PRODUCTS 375/376LR	Conductor SIZE AWG or kcmil	Symbol for X		
		Strand./ Compr.	Compt./ Solid.	
		1/0	5240	5230
		2/0	5250	5240
		3/0	5260	5250
4/0	5270	5260		

Table X3 USE FOR FOLLOWING PRODUCT 35MTG	Conductor SIZE AWG or kcmil	Symbol for X	
		Strand./ Compr.	Compt./ Solid.
	#6	3	–
	#5	3	–
	#4	2	3
	#3	2	–
	#2	1	2
	#1	0	1
	1/0	10	0
	2/0	20	10
	3/0	30	20
	4/0	40	30
	250	250	40
	300	300	250
	350	350	300
	400	400	350
	450	450	400
500	500	450	
550	550	500	
600	600	500	
650-700	550	550	
750	750	600	
800	800	550	
900	900	750	
1000	1000	900	

Table X4 USE FOR FOLLOWING PRODUCT 16THGS 16CAS	Riser Conductor Size.	Symbol for X
	AWG Solid	
	#2	2
	#1	2
	1/0	10
	2/0	20
3/0	30	
4/0	30	

Table X5 USE FOR FOLLOWING PRODUCTS 151SP 151SR	Conductor AGW or kcmil	Aluminum Conductors	
		Symbol for X	
		Strand./ Compr.	Compr./ Solid.
	#4	2AX	–
	#2	1AX	2AX
	#1	0AX	1AX
	1/0	10AX	0AX
	2/0	20AX	10AX
	3/0	30AX	20AX
	4/0	40AX	30AX
250	–	40AX	
Conductor AGW or kcmil	Copper Conductors		
	Symbol for X		
		Strand./ Compr.	Compr./ Solid.
	#6	3	–
	#4	2	3
	#2	1	2
	#1	0	1
	1/0	10	0
	2/0	20	10
	3/0	–	20

Table X6 USE FOR FOLLOWING PRODUCTS 655/656LRTP K655/656LRTP 755/756LRTP K656I/Y/H K655/656LR 755/756LR K655/656SR 655/656LINK K655/656LINK 755/756LINK 655/656ETP K655/656ETP 755/756ETP 655/656BI-LINK K655/656BI-LINK 755BI-LINK 655CK 755CK 655TCK 03600 03602 03700 03702	Conductor SIZE AWG or kcmil	Symbol for X	
		Strand./ Compr.	Compt./ Solid.
	1/0	240	230
	2/0	250	240
	3/0	260	250
	4/0	270	260
	250	280	270
	300	290	280
	350	300	290
	400	310	300
	450	320	310
	500	330	320
	550	340	320
	600	350	330
	650	360	340
700	380	350	
750	380	360	
800	390	360	
900	400	380	
1000	410	400	
1250	440	420	

Table X7 USE FOR FOLLOWING PRODUCTS 15PCJ1 25PCJ1 35PCJ1 15PCJ2 25PCJ2 35PCJ2	Conductor SIZE AWG or kcmil	Symbol for X	
		Strand./ Compr.	Compt./ Solid.
	#6	180	–
	#5	190	180
	#4	200	190
	#3	210	200
	#2	220	210
	#1	230	220
	1/0	240	230
	2/0	250	240
	3/0	260	250
	4/0	270	260
	250	280	270
	300	290	280
	350	300	290
	400	310	300
	450	320	310
500	330	320	
550	340	320	
600	350	330	
650	360	340	
700	380	350	
750	380	360	
800	390	360	
900	400	380	
1000	410	400	
1250	440	420	

Table X8 USE FOR FOLLOWING PRODUCT 16THG K151LS K151LY 16TCA	Conductor SIZE AWG or kcmil	Symbol for X	
		Strand./ Compr.	Compt./ Solid.
	#6	180	–
	#5	190	180
	#4	200	190
	#3	210	200
	#2	220	210
	#1	230	220
	1/0	240	230
	2/0	250	240
	3/0	260	250
4/0	270	260	

Table X9 USE FOR FOLLOWING PRODUCTS PCT1 PCT2 01000 01010	Conductor SIZE AWG or kcmil	Symbol for X	
		Strand./ Compr.	Compt./ Solid.
	#2	220	210
	#1	230	220
	1/0	240	230
	2/0	250	240
	3/0	260	250
4/0	270	260	

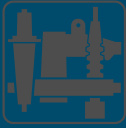

AEIC CABLE INSULATION DIAMETER REFERENCE

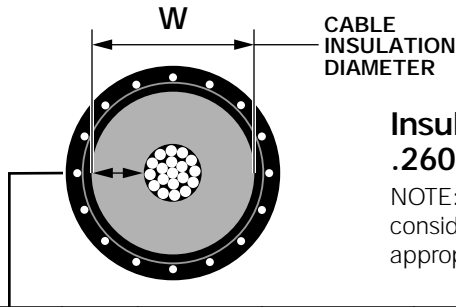

Insulation Diameters for Standard AEIC Cables with .175, .220, .260 or .345 inch wall XLP or EPR solid dielectric insulation.

NOTE: The insulation diameters shown have a $\pm .030$ inch tolerance which should be considered when selecting the minimum and maximum component sizing from the appropriate W table.

AWG or kcMil	Insulation Wall Thickness Inches	Voltage Class	w/stranded conductor	w/compressed conductor	w/compact or solid conductor
			Insulation Dia. (Inches)	Insulation Dia. (Inches)	Insulation Dia. (Inches)
#2 Solid	.175	15kV	—	—	.670
	.220	15kV	—	—	.760
	.260	25kV	—	—	—
	.345	35kV	—	—	—
#2	.175	15kV	.700	.695	.680
	.220	15kV	.790	.785	.770
	.260	25kV	—	—	—
	.345	35kV	—	—	—
#1 Solid	.175	15kV	—	—	.700
	.220	15kV	—	—	.790
	.260	25kV	—	—	.870
	.345	35kV	—	—	—
#1	.175	15kV	.740	.730	.710
	.220	15kV	.830	.820	.800
	.260	25kV	.910	.900	.880
	.345	35kV	—	—	—
1/0 Solid	.175	15kV	—	—	.735
	.220	15kV	—	—	.825
	.260	25kV	—	—	.905
	.345	35kV	—	—	1.075
1/0	.175	15kV	.785	.770	.745
	.220	15kV	.875	.860	.835
	.260	25kV	.955	.940	.915
	.345	35kV	1.125	1.110	1.085
2/0	.175	15kV	.830	.815	.785
	.220	15kV	.920	.905	.875
	.260	25kV	1.000	.985	.955
	.345	35kV	1.170	1.155	1.125
3/0	.175	15kV	.880	.865	.835
	.220	15kV	.970	.955	.925
	.260	25kV	1.050	1.035	1.005
	.345	35kV	1.220	1.205	1.175
4/0	.175	15kV	.940	.920	.885
	.220	15kV	1.030	1.010	.975
	.260	25kV	1.110	1.090	1.055
	.345	35kV	1.280	1.260	1.225
250	.175	15kV	.995	.980	.940
	.220	15kV	1.085	1.070	1.030
	.260	25kV	1.175	1.160	1.120
	.345	35kV	1.350	1.335	1.295
350	.175	15kV	1.100	1.080	1.035
	.220	15kV	1.190	1.170	1.125
	.260	25kV	1.280	1.260	1.215
	.345	35kV	1.455	1.435	1.390

AWG or kcMil	Insulation Wall Thickness Inches	Voltage Class	w/stranded conductor	w/compressed conductor	w/compact or solid conductor
			Insulation Dia. (Inches)	Insulation Dia. (Inches)	Insulation Dia. (Inches)
500	.175	15kV	1.235	1.210	1.155
	.220	15kV	1.325	1.300	1.245
	.260	25kV	1.415	1.390	1.335
	.345	35kV	1.590	1.565	1.510
600	.175	15kV	1.325	1.295	1.245
	.220	15kV	1.415	1.385	1.335
	.260	25kV	1.505	1.475	1.425
	.345	35kV	1.680	1.650	1.600
700	.175	15kV	1.395	1.365	1.305
	.220	15kV	1.485	1.455	1.395
	.260	25kV	1.575	1.545	1.485
	.345	35kV	1.750	1.720	1.660
750	.175	15kV	1.430	1.400	1.340
	.220	15kV	1.520	1.490	1.430
	.260	25kV	1.610	1.580	1.520
	.345	35kV	1.785	1.755	1.695
800	.175	15kV	1.460	1.430	1.370
	.220	15kV	1.550	1.520	1.460
	.260	25kV	1.640	1.610	1.550
	.345	35kV	1.815	1.785	1.725
900	.175	15kV	1.525	1.490	1.430
	.220	15kV	1.615	1.580	1.520
	.260	25kV	1.705	1.670	1.610
	.345	35kV	1.880	1.845	1.785
1000	.175	15kV	1.580	1.545	1.490
	.220	15kV	1.670	1.635	1.580
	.260	25kV	1.760	1.725	1.670
	.345	35kV	1.935	1.900	1.845

CABLE CONDUCTOR DIAMETER REFERENCE

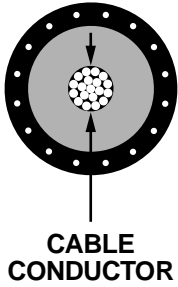

Conductor Diameters for Copper and Aluminum Stranded, Compressed, Compact and Solid Cables

Conductor Size AWG or kcmil	No. of Strands and their Nom. Strand Dia. (in.)	Cross-sectional Area		Stranded Conductors (Inches)	Compressed Conductors (Inches)	Compact Conductors (Inches)	Solid Conductors (Inches)
		Square Inches	mm ² Conversion				
14	7 x .0242	.0032	2.08	.073	—	—	.064
12	7 x .0305	.0051	3.31	.092	—	—	.081
10	7 x .0385	.0082	5.26	.116	—	—	.102
8	7 x .0486	.0130	8.37	.146	—	—	.129
6	7 x .0612	.0206	13.30	.184	—	—	.162
4	7 x .0772	.0328	21.15	.232	—	—	.204
2	7 x .0974	.0521	33.62	.292	.283	.268	.258
1	19 x .0664	.0657	42.41	.332	.322	.299	.289
1/0	19 x .0745	.0829	53.49	.373	.362	.336	.325
2/0	19 x .0837	.1054	67.43	.418	.405	.376	—
3/0	19 x .0940	.1318	85.01	.470	.456	.423	—
4/0	19 x .1055	.1662	107.2	.528	.512	.475	—
250	37 x .0822	.1964	127	.575	.558	.520	—
350	37 x .0973	.2749	177	.681	.661	.616	—
500	37 x .1162	.3924	253	.813	.789	.736	—
600	61 x .0992	.4712	304	.893	.866	.813	—
700	61 x .1071	.5498	355	.964	.935	.877	—
750	61 x .1109	.5890	380	.998	.968	.908	—
800	61 x .1145	.6283	405	1.031	1.000	.938	—
900	61 x .1215	.7069	456	1.094	1.061	.999	—
1000	61 x .1280	.7854	507	1.152	1.117	1.060	—
1100	91 x .1099	.8639	557	1.209	1.173	—	—
1200	91 x .1148	.9425	608	1.263	1.225	—	—
1250	91 x .1172	.9818	633	1.289	1.250	—	—
1300	91 x .1195	1.021	659	1.315	1.276	—	—
1400	91 x .1240	1.100	709	1.364	1.323	—	—
1500	91 x .1284	1.178	760	1.412	1.370	—	—
1600	127 x .1122	1.257	811	1.459	1.415	—	—
1700	127 x .1157	1.335	861	1.504	1.459	—	—
1750	127 x .1174	1.374	887	1.526	1.480	—	—
1800	127 x .1191	1.414	912	1.548	1.502	—	—
1900	127 x .1223	1.492	963	1.590	1.542	—	—
2000	127 x .1225	1.571	1010	1.632	1.583	—	—



EQUIPMENT BUSHINGS

Elastimold manufactures a complete line of 200 Amp deepwell and 600 Series apparatus bushings for use on transformers, switchgear and other equipment applications. The bushings incorporate IEEE 386 standard interfaces (shown on page 3) and are constructed of molded epoxy with stainless steel flanges for mounting by welding or gasketed clamp. K1601PCC series bushings are provided with a

molded epoxy flange for gasketed clamp mounting only. Bushings are available for use on AIR, OIL or SF6 insulated equipment. Units are rated for submersible, padmount, indoor, outdoor and other applications. Options include hold-down bail tabs and replaceable studs for 200 Amp deepwell bushings.

Illustration (not to scale)	Description	Voltage Class	ELASTIMOLD Part Number	Notes
	Short Shank Well with bail tabs and non-replaceable well stud	15/25kV 35kV	K1601PC-S1 L1601PC-S1	N1,9 N1,9
	Short Shank Well with bail tabs and with replaceable well stud	15/25kV 35kV	K1601PC-S1-R L1601PC-S1-R	N1,7,9 N1,7,9
	Short Shank Well without bail tabs and non-replaceable well stud	15/25kV 35kV	K1601PC-S2 L1601PC-S2	N1,7,9 N1,9
	Short Shank Well without bail tabs and with replaceable well stud	15/25kV 35kV	K1601PC-S2-R L1601PC-S2-R	N1,7,9 N1,7,9
	Long Shank Well with bail tabs and non-replaceable well stud	15/25kV 35kV	K1601PC-T1 L1601PC-T1	N2,9 N2,9
	Long Shank Well with bail tabs and with replaceable well stud	15/25kV 35kV	K1601PC-T1-R L1601PC-T1-R	N2,7,9 N2,7,9
	Long Shank Well without bail tabs and non-replaceable well stud	15/25kV 35kV	K1601PC-T2 L1601PC-T2	N2,9 N2,9
	Long Shank Well without bail tabs and with replaceable well stud	15/25kV 35kV	K1601PC-T2-R L1601PC-T2-R	N2,7,9 N2,7,9
	Epoxy Flange Well	15/25kV	K1601PCC	N1,7,9
	Epoxy Flange Well with replaceable well stud	15/25kV	K1601PCC-R	N1,7,9
	Well w/Insert (K1601PCC-R & 1601A4)	15kV	1601CABA4R	N1,9
	Well w/Insert (K1601PCC-R & 2701A4)	25kV	2701CABA4R	N1,9
	200 A Deadbreak Integral Bushing	15/25kV	K180T4	N3,9
	200 A Deadbreak Integral Bushing	15/25kV	K180C4	N2,9
	600 A Short Shank Bushing w/stud	15/25kV	K600S1	N4,8,10
	600 A Short Shank Bushing w.o./stud	15/25kV	K650S1	N4,8,11
	600 A Short Shank Bushing w.o./stud	35kV	750S1	N4,8,11
	600 A Cu Short Shank Bushing w.o./stud	15/25kV	K675S1	N4,9,11
	600 A Long Shank Bushing w/stud	15/25kV	K600T1	N5,8,10
	600 A Long Shank Bushing w.o./stud	15/25kV	K650T1	N5,8,11
	600 A Cu Long Shank Bushing w.o./stud	15/25kV	K675T1	N5,9,11
	600 A 12" Long Shank Bushing w/stud	15/25kV	K600L12	N6,8,10
	600 A In-Air Long Shank Bushing w/stud	15/25kV	K600TBC	N5,8,10,12
	600 A Cu In-Air Long Shank Bush. w/stud	15/25kV	K675TBC	N5,9,10,12
	Boot & Collars for K600T1 to use in air	15/25kV	600BC	N12

- N1. Bushing shank length = 2 - 3/4 inches.
- N2. Bushing shank length = 9 - 1/4 inches
- N3. Bushing shank length = 7 - 11/32 inches.
- N4. Bushing shank length = 2 - 5/16 inches.
- N5. Bushing shank length = 8 - 37/64 inches.
- N6. Bushing shank length = 12 inches.
- N7. Replacement stud available separately. Specify 1601RS.
- N8. Equipped with standard aluminum conductor rod.
- N9. Equipped with copper conductor rod.
- N10. Includes 5/8-11 threaded stud at elbow end.
- N11. Includes 5/8-11 threaded hole at elbow end.
- N12. Provides increased creep and strike.



CABLE JOINTS, CABLE TERMINATIONS, CABLE GLANDS, CABLE CLEATS
FEEDER PILLARS, FUSE LINKS, ARC FLASH, CABLE ROLLERS, CUT-OUTS

11KV 33KV CABLE JOINTS & CABLE TERMINATIONS
FURSE EARTHING
www.cablejoints.co.uk
Thorne and Derrick UK
Tel 0044 191 490 1547 Fax 0044 191 477 5371
Tel 0044 117 977 4647 Fax 0044 117 9775582