



CABLE JOINTS, CABLE TERMINATIONS, CABLE GLANDS, CABLE CLEATS,  
FEEDER PILLARS, FUSE LINKS, ARC FLASH, CABLE ROLLERS, CUT-OUTS

11KV-33KV CABLE JOINTS & CABLE TERMINATIONS  
FURSE EARTHING  
www.elastimold.co.uk  
Thorne and Derrick UK  
Tel: 0044 191 480 1647 Fax: 0044 191 477 5371  
Tel: 0044 117 977 4647 Fax: 0044 117 977 5862



# CABLE ACCESSORIES

PG-CA-0307

**For 5kV-35kV  
Distribution Systems**

**Loadbreak & Deadbreak  
Separable Connectors**

**Cable Joints**

**Cable Terminations**



## Product Selection Guide

POWER DELIVER



Product Guide PG-CA provides an easy-to-use, comprehensive listing of ELASTIMOLD products for 5kV thru 35kV underground power distribution systems. Included are separable elbow connectors, cable joints, terminations and other cable accessory components. This catalog incorporates information relative to product application, ratings and selection.

ELASTIMOLD is recognized as the leading producer of premolded cable accessory components worldwide. Utilizing specially formulated materials with 100% peroxide-cured insulation and shielding, Elastimold products represent the state-of-the-art in premolded process technology. Durable, quality construction and non-degrading, high-reliability, maintenance-free performance is assured when specifying ELASTIMOLD products.

ELASTIMOLD's broad line of premolded products offers significant advantages over field-fabricated and other alternatives, including: 100% factory assurance testing prior to delivery and installation; simplified, single-piece construction with built-in insulating, shielding and sealing surfaces; ease of installation with no special skills or tools required; and compact, lightweight, durable designs for easy handling and application.

**Separable Elbow Connectors** and their related accessories are available in 200 Amp loadbreak, 200 Amp deadbreak and 600 Amp deadbreak styles. Rated for padmount, subsurface, vault, indoor, outdoor and other applications, units feature interchangeable interfaces which can be easily engaged or separated to provide a convenient method to connect or disconnect cable and equipment in a distribution system.

**Cable Joints** are available in permanently crimped or bolted (separable) connector styles. Permanently crimped units are rated the same as the cable they are connecting and are available for all applications including direct buried.

**Cable Terminations** are available in single-piece or modular designs. Rated for indoor, outdoor or padmount applications, units allow connection and transition from shielded underground cables to bare overhead conductors and live-front equipment.

**Elastimold Special Component Services Group** provides custom products tailored to specific application requirements. Please contact the factory for further information regarding this service.

Surge Arresters and Fused Elbows see Elastimold® Product Guide, PG-PC-E and PG-PC-H.

<b>Certified Tests &amp; Performance</b>	
Ratings	Pg. 2
<b>Separable Connector Interfaces</b>	
Standard Interfaces for Separable Connectors, Components & Equipment Bushings	Pg. 3
<b>Separable Connectors</b>	
200 Amp Loadbreak	Pg. 4-7
200 Amp Deadbreak	8-9
600 Series Deadbreak	10-13
600 Series Deadbreak – Cam-Op™, Link-Op™	14-15
600 Series Deadbreak – Stick-Op™, Window-Op™	16-17
600 Series Deadbreak – Cable Joints	18-19
<b>Molded Multi-Point Junctions</b>	
Molded Multi-Point Junctions	Pg. 20-21
<b>PCJ Cable Joints</b>	
Cable Joints	Pg. 22-23
<b>Cable Terminations</b>	
Cable Terminations	Pg. 24-27
<b>Shield Adapters, Grounding Kits and Jacket Seals</b>	
Shield Adapters, Sealing & Grounding	Pg. 28-29
<b>Equipment Bushings</b>	
Equipment Bushings	Pg. 30
<b>Reference</b>	
How to Specify Size-Sensitive Products	Pg. 32-33
AEIC & ICEA Cable Insulation Diameter	34-36
Cable Conductor Diameter	37
WX Size Tables	38-39
<b>Index</b>	
Index	Pg. 40-41

Elastimold Separable Connectors, Cable Joints, Cable Terminators and other cable accessory products have been designed and tested per applicable portions of IEEE, ANSI and other industry standards including:

- IEEE 386™ Standard For Separable Connectors
- IEEE 404™ Standard For Cable Joints and Splices
- IEEE 48™ Standard For Cable Terminations

- IEEE 592™ Standard For Exposed Semiconducting Shields
- ANSI C119.4 Standard For Copper and Aluminum Conductor Connectors
- AEIC CS8 Standards For XLP and EPR Insulated Cables
- ICEA S-94-649-2004 and S-97-682-2000 Standard for Cables Rated 5,000 – 46,000 Volts

### CABLE JOINTS AND TERMINATIONS RATINGS

Refer to the pages listed below for rating information:

- PCJ Cable Joints, page 22.
- Cable Terminations, page 24.

### SEPARABLE CONNECTOR RATINGS

Table 1 shows voltage and current ratings which apply to all Separable Connectors including 200 AMP Loadbreak, 200 AMP Deadbreak and 600 Series Deadbreak products. Table 2 shows switching and fault close ratings which only apply to 200 AMP Loadbreak Connectors.

TABLE 1	15kV Class Ratings	25kV Class Ratings	35kV Class Ratings
<ul style="list-style-type: none"> <li>• <b>OPERATING VOLTAGE</b> Maximum line-to-ground (See Application Info Note 1)</li> </ul>	8.3kV	15.2kV	21.1kV
<ul style="list-style-type: none"> <li>• <b>BIL</b> Impulse withstand 1.2 x 50 microsecond wave</li> </ul>	95kV	125kV	150kV
<ul style="list-style-type: none"> <li>• <b>WITHSTAND VOLTAGE</b> AC One Minute DC Fifteen Minute</li> </ul>	34kV 53kV	40kV 78kV	50kV 103kV
<ul style="list-style-type: none"> <li>• <b>CORONA EXTINCTION LEVEL @ 3pC Sensitivity</b></li> </ul>	11kV	19kV	26kV
<ul style="list-style-type: none"> <li>• <b>200 AMP Products</b> Continuous Current: Symmetrical Momentary Current:</li> <li>• <b>600 Series Products</b> Continuous Current: Symmetrical Momentary Current:</li> </ul>	200 AMP* 10kA sym, 10 cycle duration  600 and 900 AMP* 25kA sym, 10 cycle duration  * Designed for 90° C maximum continuous operating temperature		

TABLE 2	LOADMAKE/LOADBREAK SWITCHING	FAULT CLOSE
<b>15kV Class Ratings</b>	<ul style="list-style-type: none"> <li>• 1Ø and 3Ø circuits 8.3kV line to ground, 14.4kV max. across open contacts.</li> <li>• 10 loadmake/break operations at 200 Amps max. with 70 to 80% lagging power factor.</li> </ul>	1 fault close operation at 8.3kV or 14.4kV; 10,000 Amps, rms, sym. 10 cycles (0.17 sec.) 1.3 max. asym factor applies to new or used mating parts (up to maximum designated switching operations.)
<b>25kV Class Ratings</b>	<ul style="list-style-type: none"> <li>• 1Ø and 3Ø circuits 15.2kV line to ground, 26.3kV max. across open contacts.</li> <li>• 10 loadmake/break operations at 200 Amps max. with 70 to 80% lagging power factor.</li> </ul>	1 fault close operation at 15.2kV or 26.3kV; 10,000 Amps, rms, sym. 10 cycles (0.17 sec.) 1.3 max. asym factor applies to new or used mating parts (up to maximum designated switching operations.)
<b>35kV Class Ratings</b>	<ul style="list-style-type: none"> <li>• 1Ø and 3Ø circuits 21.1kV line to ground, 36.6kV max. across open contacts.</li> <li>• 10 loadmake/break operations at 200 Amps max. with 70 to 80% lagging power factor.</li> </ul>	1 fault close operation at 21.1kV or 36.6kV; 10,000 Amps, rms, sym. 10 cycles (0.17 sec.) 1.3 max. asym factor applies to new or used mating parts (up to maximum designated switching operations.)







### APPLICATION INFORMATION:

1. Loadbreak connectors are designed and rated for use on grounded WYE systems. For application on ungrounded WYE or delta systems, the next higher voltage class product is recommended. Examples: 5kV ungrounded: use 15kV class products; 15kV ungrounded: use 25kV class products; 25kV ungrounded: use 35kV class products.
2. Products are designed and constructed for all applications including padmount, subsurface, vault, indoor, outdoor, direct sunlight, direct buried and continuously submerged in water.
3. Products are designed and rated for ambient temperatures of -40° C to +65° C. It is recommended that loadbreak connectors be hotstick operated at -20° C to +65° C ambient temperature range and at altitudes not exceeding 6000 feet.

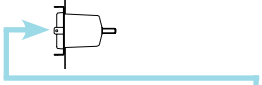
## Standard Interfaces for Separable Connectors, Components and Equipment Bushings

ANSI/IEEE Standard 386 defines the specific interface dimensions that 200 Amp and 600 Series elbows, inserts, junctions, equipment bushings and any mating components must conform to insure

interchangeability. The table below provides information concerning the types of interfaces supplied by Elastimold for various applications and is useful to assure proper matching of components.

Bushing Interface	Voltage Class	Interface Description	Standard No. Figure No.
 <p><b>A</b> 200 AMP DEEPWELL EQUIPMENT BUSHING</p>	15kV, 25kV and 35kV	200 AMP Bushing Well Interface 8.3kV, 15.2kV, 21.1kV	<b>A</b> IEEE 386-2001 Fig. 3
 <p><b>B</b> 200 AMP LOADBREAK INSERT</p>	15kV	200 AMP Loadbreak 8.3kV and 8.3kV/14.4kV	<b>B</b> IEEE 386-2001 Fig. 5
 <p><b>C</b> 200 AMP LOADBREAK INSERT</p>	25kV	200 AMP Loadbreak 15.2kV and 15.2kV/26.3kV	<b>C</b> IEEE 386-2001 Fig. 7, Note 1
 <p><b>D</b> 200 AMP LOADBREAK INSERT</p>	35kV	200 AMP Loadbreak Interface No. 2 21.1kV and 21.1kV/36.6kV	<b>D</b> IEEE 386-2001 Fig. 7, Note 1
 <p><b>E</b> 200 AMP DEADBREAK INSERT</p>	15kV and 25kV	200 AMP Deadbreak 8.3kV and 15.2kV	<b>E</b> IEEE 386-2001 Fig. 4
 <p><b>F</b> 600 SERIES EQUIPMENT BUSHING</p>	15kV and 25kV	600 AMP Deadbreak Interface No.1 8.3kV and 15.2kV	<b>F</b> IEEE 386-2001 Fig.11
 <p><b>G</b> 600 SERIES EQUIPMENT BUSHING</p>	35kV	600 AMP Deadbreak Interface No.1 21.1kV	<b>G</b> IEEE 386-2001 Fig.13

NOTES:  
1. Elastimold uses Fig. 7 interface for both 25 and 35kV applications.

200 Amp loadbreak connectors and accessories provide a convenient method to connect/disconnect cable and equipment on power distribution systems. Loadbreak elbows include provisions for energized operation using standard hotstick tools, allowing loadmake/break operation and a visible disconnect. Components can be isolated with insulated caps, plugs and parking bushings.

Optional accessories allow system grounding, testing, bypass, lightning surge protection and current limiting fusing. Additional connecting points and taps can be provided by use of junctions or feed-thrus.

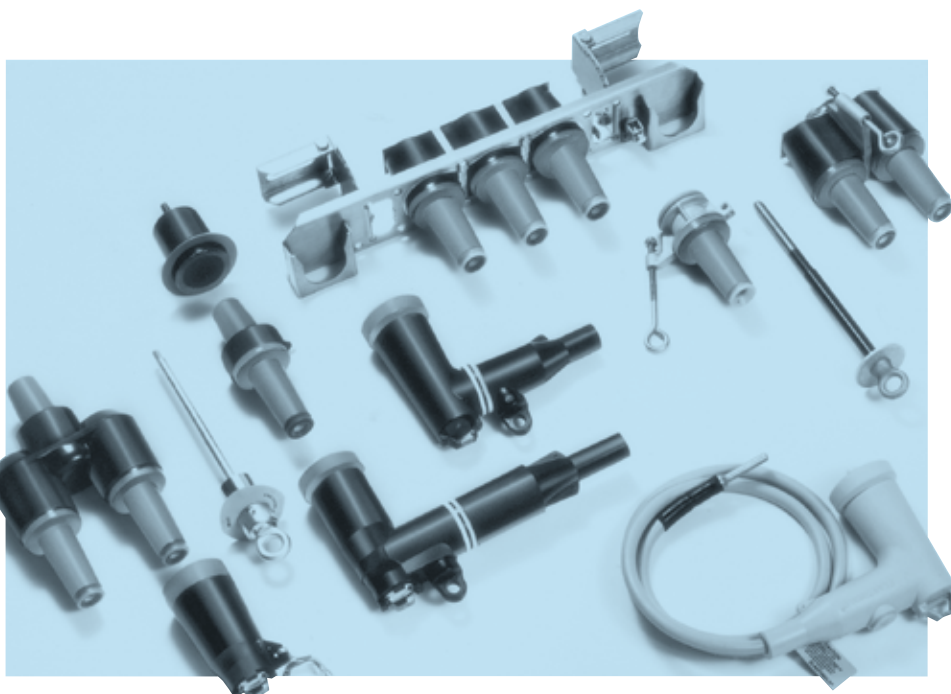

### RATINGS OVERVIEW

See page 2 for complete information including switching and fault close ratings.

#### CURRENT RATINGS

200A Continuous  
10kA sym. 10 Cycles

#### VOLTAGE RATINGS

##### 15kV Class

8.3kV Phase-to-Ground  
14.4kV Phase-to-Phase  
95kV BIL  
34kV AC Withstand  
53kV DC Withstand  
11kV Corona Extinction

##### 25kV Class

15.2kV Phase-to-Ground  
26.3kV Phase-to-Phase  
125kV BIL  
40kV AC Withstand  
78kV DC Withstand  
19kV Corona Extinction

##### 35kV Class

21.1kV Phase-to-Ground  
36.6kV Phase-to-Phase  
150kV BIL  
50kV AC Withstand  
103kV DC Withstand  
26kV Corona Extinction

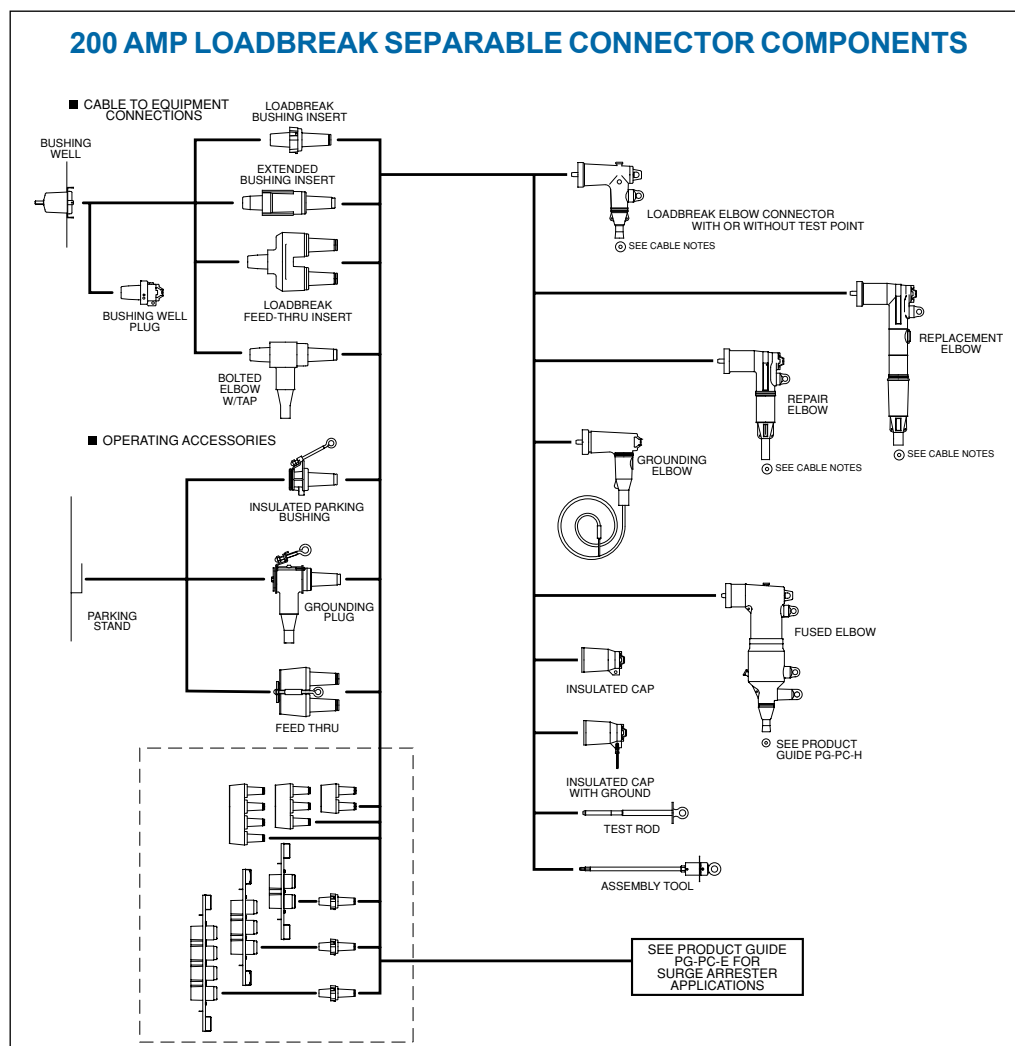

Separable Connectors  
200A Loadbreak

Illustration (not to scale)	Description	Voltage Class	ELASTIMOLD Part Number	Notes
	Elbow Connector	15kV	<b>165LR-W5X</b> Use Tables W1 and X1	N2,3,4,5
		25kV	<b>275LR-W5X</b> Use Tables W16 and X1	N2,3,4,5
		35kV	<b>375LR-W5X</b> Use Tables W3 and X2	N2,3,5
	Elbow Connector w/ Test Point	15kV	<b>166LR-W5X</b> Use Tables W1 and X1	N2,3,4,5
		25kV	<b>276LR-W5X</b> Use Tables W16 and X1	N2,3,4,5
		35kV	<b>376LR-W5X</b> Use Tables W3 and X2	N2,3,5
	Jacket Seal Elbow Connector	15kV	<b>165LRJS-W5X</b> Use Table W1 (B&C sizes only) and Table X1	N2,19
		25kV	<b>275LRJS-W5X</b> Use Tables W16 and X1	N2,19
	Jacket Seal Elbow Connector w/ Test Point	15kV	<b>166LRJS-W5X</b> Use Tables W1 (B&C sizes only) and Table X1	N2,19
		25kV	<b>276LRJS-W5X</b> Use Tables W16 and X1	N2,19
	Repair Elbow Connector	15kV	<b>167ELR-W5X</b> Use Tables W5 and X1	N5,10,18
		25kV	<b>273ELR-W5X</b> Use Tables W5 and X1	N5,10,18
	Repair Elbow Connector w/ Test Point	15kV	<b>168ELR-W5X</b> Use Tables W5 and X1	N5,10,18
		25kV	<b>274ELR-W5X</b> Use Tables W5 and X1	N5,10,18
	Replacement Elbow	15kV	<b>167RLR-W5X</b> Use Tables W4 and X1	N5,11,13
		25kV	<b>273RLR-W5X</b> Use Tables W2 and X1	N5,11,13
	Replacement Elbow w/ Test Point	15kV	<b>168RLR-W5X</b> Use Tables W4 and X1	N5,11,13
		25kV	<b>274RLR-W5X</b> Use Tables W2 and X1	N5,11,13
	Direct Test Elbow Connector	15kV	<b>167DLR-W5X</b>	N2,5,22
		25kV	<b>273DLR-W5X</b>	N2,5,22
	Direct Test Repair Elbow Connector	15kV	<b>167DELR-W5X</b>	N5,10,18,22
		25kV	<b>273DELR-W5X</b>	N5,10,18,22
	Direct Test Repair Elbow Connector w/Test Point	15kV	<b>168DELR-W5X</b>	N5,10,18,22
		25kV	<b>274DELR-W5X</b>	N5,10,18,22
	Fused Elbow (Full Range Current Limiting)	15kV	<b>168FLR H-W0X</b>	
		25kV	<b>274FLR H-W0X</b> See Product Guide PG-PC-H	
	Bolted Elbow w/ Tap	15kV	<b>167LRT-W5X</b> Use Tables W4 and X1	N17
	Bushing Insert	15kV	<b>1601A4</b>	N4,8,20
		25kV	<b>2701A4</b>	N4,8,20
		35kV	<b>3701A4</b>	N6,21
		35kV	<b>3701A3</b>	N8,21
	Extended Bushing Insert	15kV	<b>1601EA4</b>	N8,20
		25kV	<b>2701EA4</b>	N8,20
	Feed-Thru Insert	15kV	<b>1602A3R</b>	N16
		25kV	<b>2702A1</b>	N16
		35kV	<b>3702A1</b>	N6,16
	Insulated Cap	15kV	<b>160DR</b>	N9
	Insulated Cap w/ Ground	15kV	<b>160DRG</b>	N9
		15kV	<b>167DRG</b>	N7,9
		25kV	<b>273DRG</b>	N7,9
		35kV	<b>375DRG</b>	N7,9

Illustration (not to scale)	Description	Voltage Class	ELASTIMOLD Part Number	Notes	
	Insulated Cap w/ Ground and Test Point	15kV	<b>168DRG</b>	N7	
		25kV	<b>274DRG</b>	N7	
		35kV	<b>376DRG</b>	N7	
	Grounding Plug (1/0 AWG x 6' Ground Lead)	15kV 25kV	<b>161GP</b> <b>272GP</b>		
	Grounding Elbow (1/0 AWG x 6' Ground Lead)	15kV 25/35kV	<b>160GLR</b> <b>370GLR</b>	N12	
	Feed-Thru	15kV 25kV 35kV	<b>164FT</b> <b>274FT</b> <b>371FT</b> <b>373FT</b>	N6	
		Feed-Thru Vertical	15kV 25kV 35kV	<b>164FTV</b> <b>274FTV</b> <b>373FTV</b>	
	Adjustable Bracket 2-point Feed-Thru	15kV 25kV	<b>164FT2-AB</b> <b>274FT2-AB</b>	N23 N23	
		Adjustable Bracket 3-point Feed-Thru	15kV 25kV	<b>164FT3-AB</b> <b>274FT3-AB</b>	N23 N23
		Adjustable Bracket 4-point Feed-Thru	15kV 25kV	<b>164FT4-AB</b> <b>274FT4-AB</b>	N23 N23
	Feed-Thru Well	15/25kV	<b>K1601WFT</b>		
		Feed-Thru Well Vertical	15/25kV	<b>K1601WFTV</b>	
	Insulated Parking Bushing	15kV 25kV 35kV	<b>161SOP</b> <b>272SOP</b> <b>372SOP</b>	N20 N20 N21	
		15kV 25kV	<b>164SOP</b> <b>274SOP</b>	N20,23 N20,23	
		Test Rod	ALL	<b>370TR</b>	
	Bushing Well Plug	15/25kV 35kV	<b>276BWP</b> <b>M276BWP</b>		
	Assembly Tool	ALL	<b>200AT</b>	N8	

- N1. Copper lug for use on COPPER CONDUCTOR ONLY.
- N2. W5X indicates that the part number includes 02500X long bi-metal compression lug as standard. For an all-copper lug, replace W5X with W2X in Table X1 to specify the all-copper 02702X lug.
- N3. Also available as housing only. Specify: 165BLR-W; 275BLR-W; 375BLR-W; 166BLR-W; 276BLR-W; 376BLR-W.
- N4. Also available as elbow/insert combination. Specify: 165A4-WX; 275A4-WX; 166A4-WX; 276A4-WX.
- N5. Also available with 200ECS jacket seal included. Add - "S" suffix to part number.
- N6. Rated for single-phase applications only.
- N7. Equipped with insulated cuff.
- N8. Includes internal torquing feature using 200AT Assembly Tool.
- N9. Also available without probe. Specify "A" suffix - Example: 273DRGA.
- N10. Repair elbow has extended length contact and elbow housing resulting in a net gain of 3-1/4" in length.
- N11. Replacement elbow has extended length contact and elbow housing resulting in a net gain of 8-7/8" in length.
- N12. Rated for 25kV thru 35kV applications.
- N13. Includes long bi-metal contact 00400X.
- N14. 160CA Cable Size Adapter can only be used with elbow part numbers 165LR/166LR C size only.
- N16. Fully rotatable for 360° positioning. Includes bail assembly to secure feed-thru insert to bushing well.
- N17. Includes 02800X bi-metal contact.
- N18. Includes 02509X long bi-metal contact.
- N19. Includes built-in jacket seal. Also available as housing only — specify: 165BLRJS-W, 166BLRJS-W, 275BLRJS-W or 276LRJS-W. Also available as elbow/insert combination — specify: 165JSA4-W5X, 166JSA4-W5X, 275JSA4-W5X or 276JSA4-W5X.
- N20. Includes a yellow seating indicator and vent ring.
- N21. Includes a black vent ring.
- N22. Direct Test Connectors, along with a 200TC-X series meter adapter, a properly rated voltage meter and Hot-line Stick provides a means for direct conductor voltage testing.
- N23. With stainless steel bracket.

**CONTACTS, PROBES, PLUGS, CABLE ADAPTERS AND JUNCTIONS CONTINUED ON PAGE 7.**

Refer to the **W** and **X** tables on pages 38 and 39 for sizing to cable insulation diameter and conductor size.  
For cable shield adapters and jacket seals, see page 28.

### RATINGS OVERVIEW

See page 2 for complete information including switching and fault close ratings.

#### CURRENT RATINGS

200A Continuous  
10kA sym. 10 Cycles

#### VOLTAGE RATINGS

##### 15kV Class

8.3kV Phase-to-Ground  
14.4kV Phase-to-Phase  
95kV BIL  
34kV AC Withstand  
53kV DC Withstand  
11kV Corona Extinction

##### 25kV Class

15.2kV Phase-to-Ground  
26.3kV Phase-to-Phase  
125kV BIL  
40kV AC Withstand  
78kV DC Withstand  
19kV Corona Extinction

##### 35kV Class

21.1kV Phase-to-Ground  
36.6kV Phase-to-Phase  
150kV BIL  
50kV AC Withstand  
103kV DC Withstand  
26kV Corona Extinction

### 200 AMP LOADBREAK SEPARABLE CONNECTOR COMPONENTS

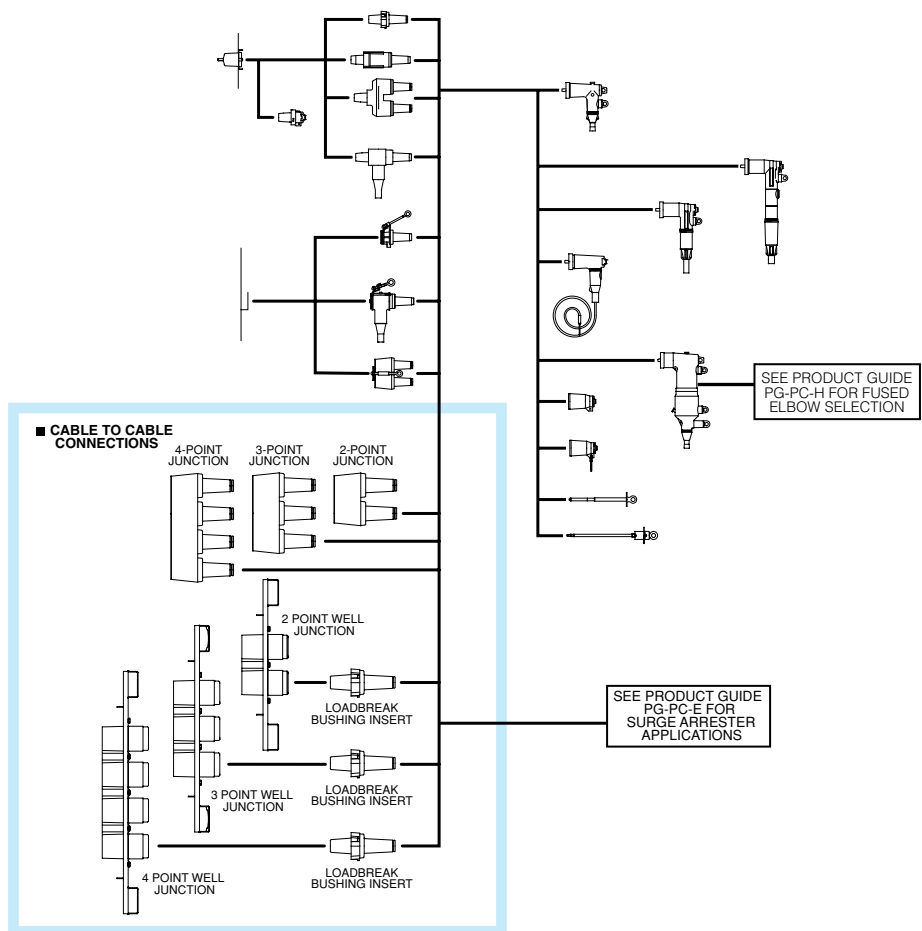

Illustration (not to scale)	Description	Voltage Class	ELASTIMOLD Part Number	Notes
	<b>Contacts:</b> Long Bi-Metal ELR Bi-Metal Copper LRT Contact RLR Contact	ALL 15/25kV ALL 15kV 15/25kV	Use Table X1 <b>02500X</b> <b>02509X</b> <b>02702X</b> <b>02800X</b> <b>00400X</b>	N1 N2 N3
	Elbow Probe	15kV 25kV 35kV	<b>166LRF</b> <b>274LRF</b> <b>375LRF</b>	
	Elbow Cable Entrance Insulating Plug	ALL	<b>10EPW</b> Use Table W6	
	Cable Size Adapter	15kV	<b>160CA-W</b> Use Table W6 EB-FA Only	N4
	Direct Voltage Test Meter Adapter for: <i>HD Electric Meters</i>	ALL	<b>200TC-1</b>	N14
	<i>Ross Meters</i>		<b>200TC-2</b>	N14
	<i>Chance Meters</i>		<b>200TC-4</b>	N14
	2-Way Well Junction w/ s.s. Bracket	15/25kV	<b>K1601WJ2</b>	N6
	2-Way Well Junction w/ "U" Straps	15/25kV	<b>K1601WJ2-5</b>	N5, 6, 11
	3-Way Well Junction w/ s.s. Bracket	15/25kV	<b>K1601WJ3</b>	N6
	3-Way Well Junction w/ "U" Straps	15/25kV	<b>K1601WJ3-5</b>	N5, 6, 12
	4-Way Well Junction w/ s.s. Bracket	15/25kV	<b>K1601WJ4</b>	N6
	4-Way Well Junction w/ "U" Straps	15/25kV	<b>K1601WJ4-5</b>	N5, 6, 13
	2-Point Junction with/stainless steel bracket	15kV 25kV 35kV	<b>164J2</b> <b>274J2</b> <b>373J2</b>	N7 N7 N7
	2-Point Junction w/"U"-straps	15kV 25kV 35kV	<b>164J2-5</b> <b>274J2-5</b> <b>373J2-5</b>	N5, 8 N5, 11 N5, 11
	3-Point Junction with/stainless steel bracket	15kV 25kV 35kV	<b>164J3</b> <b>274J3</b> <b>373J3</b>	N7 N7 N7
	3-Point Junction w/"U"-straps	15kV 25kV 35kV	<b>164J3-5</b> <b>274J3-5</b> <b>373J3-5</b>	N5, 9 N5, 12 N5, 12
	4-Point Junction with/stainless steel bracket	15kV 25kV 35kV	<b>164J4</b> <b>274J4</b> <b>373J4</b>	N7 N7 N7
	4-Point Junction w/"U"-straps	15kV 25kV 35kV	<b>164J4-5</b> <b>274J4-5</b> <b>373J4-5</b>	N5, 10 N5, 13 N5, 13

- N1. Repair elbow has extended length contact and elbow housing resulting in a net gain of 3-1/4" in length.
- N2. Copper lug for use on COPPER CONDUCTOR ONLY.
- N3. Replacement elbow has extended length contact and elbow housing resulting in a net gain of 8-7/8" in length.
- N4. 160CA Cable Size Adapter can only be used with elbow part numbers 165LR/166LR C size only.
- N5. Also available as rubber only, without straps. Specify suffix "-4" in place of "-5" in the part number.
- N6. Supplied with replaceable stud. Replacement stud available separately. Specify 1601RS.
- N7. Hardware packages, consisting of brackets & straps only, may be ordered separately by specifying "-6" in the part number. Example 164J4-6
- N8. Hardware package, consists of "U"-straps and back plate only, may be ordered separately by specifying 1601US-J2.
- N9. Hardware package, consists of "U"-straps and back plate only, may be ordered separately by specifying 1601US-J3.
- N10. Hardware package, consists of "U"-straps and back plate only, may be ordered separately by specifying 1601US-J4.
- N11. Hardware package, consists of "U"-straps and back plate only, may be ordered separately by specifying 271-68.
- N12. Hardware package, consists of "U"-straps and back plate only, may be ordered separately by specifying 271-61.
- N13. Hardware package, consists of "U"-straps and back plate only, may be ordered separately by specifying 271-70.
- N14. For use with Direct Test Connectors.

200 Amp deadbreak connectors and accessories provide a quick disconnect feature for cable and equipment connections on power distribution systems.

All deadbreak connectors must be DE-ENERGIZED before operating and must be mechanically secured with bails when connected. Components can be isolated with insulated caps, plugs and parking bushings.

All deadbreak elbows are equipped with test points as standard. Optional accessories allow system grounding, bypass and lightning surge protection. Additional connecting points and taps can be provided by use of junctions or feed-thrus.

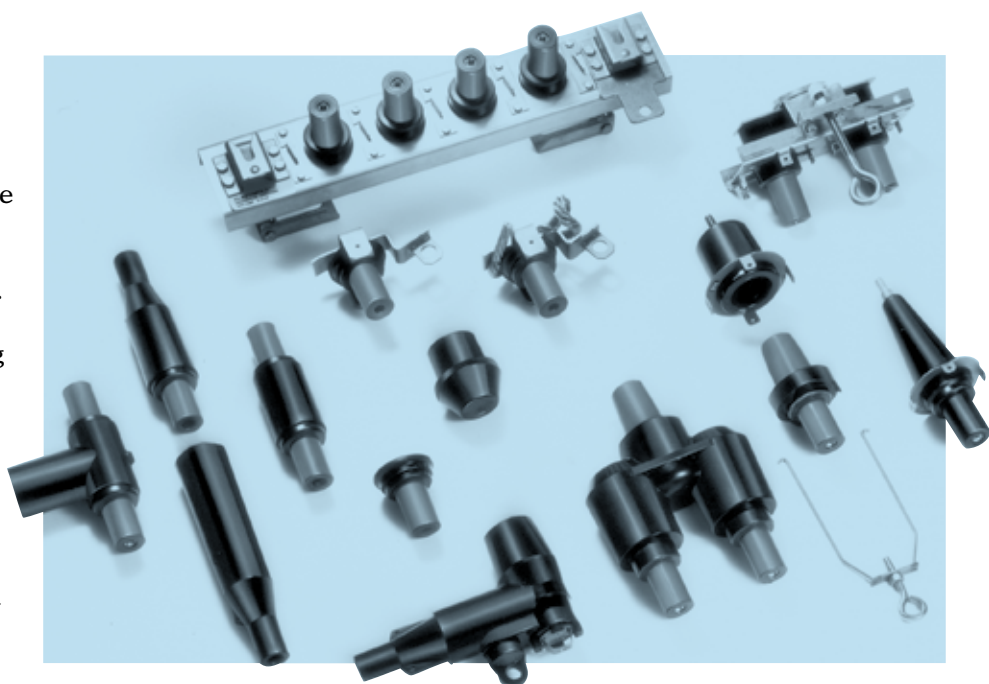

### RATINGS OVERVIEW

See page 2 for complete information.

#### CURRENT RATINGS

200A Continuous  
10kA sym. 10 Cycles

#### VOLTAGE RATINGS

##### 15kV Class

8.3kV Phase-to-Ground  
14.4kV Phase-to-Phase  
95kV BIL  
34kV AC Withstand  
53kV DC Withstand  
11kV Corona Extinction

##### 25kV Class

15.2kV Phase-to-Ground  
26.3kV Phase-to-Phase  
125kV BIL  
40kV AC Withstand  
78kV DC Withstand  
19kV Corona Extinction

### 200 AMP DEADBREAK SEPARABLE CONNECTOR COMPONENTS

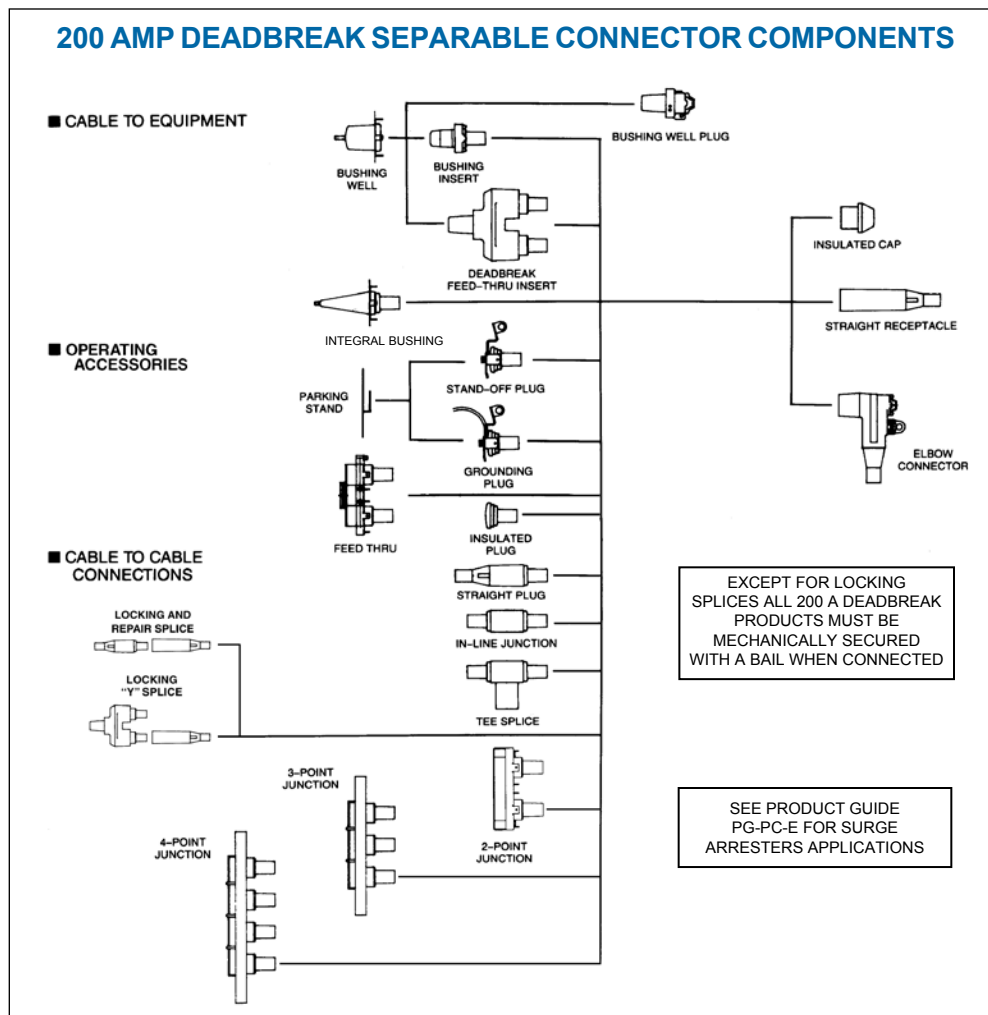

Illustration (not to scale)	Description	Voltage Class	ELASTIMOLD Part Number	Notes
	Elbow Connector w/ Test Point	15/25kV	<b>156LR-W5X</b> Use Tables W4 and X1	N1,2
	Direct Test Elbow Connector	15/25kV	<b>156DLR-W5X</b> Use Tables W4 and X1	N1,2,22
	Bail Assembly for 156LR Elbow	15/25kV	<b>150BA</b>	
	Bushing Insert	15/25kV	<b>K1501A1</b>	N3
	Feed-thru Insert	15/25kV	<b>K1502A1</b>	N3,4
	Insulated Plug	15/25kV	<b>K150DP</b>	N3
	Insulated Cap	15/25kV	<b>K150DR</b>	N3
	Insulated Parking Bushing	15/25kV	<b>K151SOP</b>	N3
	Grounding Plug	15/25kV	<b>151GP</b>	N3
	Feed-Thru	15/25kV	<b>K1501FT</b>	N3,6
	2-Point Junction	15/25kV	<b>K1501J2-U</b>	N3,6
	3-Point Junction	15/25kV	<b>K1501J3-U</b>	N3,6
	4-Point Junction	15/25kV	<b>K1501J4-U</b>	N3,6
	Elbow Probe	15/25kV	<b>156LRF</b>	
	Straight Receptacle	15/25kV	<b>K151SR-W0X</b> Use Tables W1A and X1	N3,12,13,17,18
	Straight Plug	15/25kV	<b>K151SP-W0X</b> Use Tables W1A and X1	N3,12,13,19
	Tee Splice	15/25kV	<b>K150T</b>	N3
	In-Line Junction	15/25kV	<b>K150S</b>	N3
	Locking Splice/Repair Splice	15/25kV	<b>K151LS-W0X</b> Use Tables W1A and X1	N8,9,13,15,16,17,20,23
	Locking "Y" Splice	15/25kV	<b>K151LY-W0X</b> Use Tables W1A and X1	N8,9,13,15,17,21
	BAIL	15/25kV	<b>150TB1</b>	N5
	BAIL	15/25kV	<b>150TB2</b>	N5
	BAIL	15/25kV	<b>150TB3</b>	N5

Illustration (not to scale)	Description	Voltage Class	ELASTIMOLD Part Number	Notes
	BAIL	15/25kV	<b>150TB4</b>	N5
	BAIL	15/25kV	<b>150TB5</b>	N5
	<b>Contacts:</b> Long Bi-Metal Copper	15/25kV 15/25kV	<b>02500X</b> <b>02702X</b>	N7
	Elbow Cable Entrance Insulating Plug	15/25kV	<b>10EP-W</b> Use Table W6	N10
	Cable Entrance Insulating Plug	15/25kV	<b>152EA-W</b> Use Table W6	N11
	Cable Size Adapter	15/25kV	<b>160CA-W</b> Use Table W6 EB-FA Only	N14

- N1. Includes bail assembly.
- N2. W5X indicates that the part number includes a 02500X bi-metal compression lug, which is rated for either aluminum or copper conductor, as standard. For an all-copper lug, replace W5X with W2X in Table X1 to specify the all-copper 02702X lug.
- N3. Bails are required but not included. Order separately. Consult factory for bails not listed for a specific application.
- N4. Fully rotatable for 360° positioning. Includes bail assembly to secure feed-thru insert to bushing well. Elbows bail assemblies are required but not included with the feed-thru insert.
- N5. Refer to factory for application details.
- N6. Center-to-center spacing equals 4 inches.
- N7. Copper lug for copper cable only.
- N8. To order cable legs for different cable sizes, list each leg size "W" and "X". Example: K151LY-A1240-A1240-B1220. See Tables W1 and X1 for sizes.
- N9. To order locking contacts for K151LS and K151LY, order 01401X (Al) or 01402X (Cu) for plug contact. Order 01301X (Al) or 01302X (Cu) for receptacle. See Table X1 for sizes.
- N10. For use with 156LR elbows.
- N11. For use with K151SR, K151SP, K151LS, K151LY receptacles, plugs and splices.
- N12. Also available as housing only. Specify K151BSP-W or K151BSR-W.
- N13. Also available in EB-FA sizes per table W6 by using 160CA cable adapter with C size plugs & receptacles.
- N14. 160CA cable adapter can only be used with C size plugs & receptacles.
- N15. Bails are not required for locking splices.
- N16. When used as a repair splice, the assembled length allows 4" for cable replacement/repair.
- N17. Straight receptacles are also available with test point. Specify K152SR-W0X part number.
- N18. W0X indicates that the part number includes a 01500X universal aluminum compression lug, which is rated for either aluminum or copper, as standard. For an all-copper lug, replace W0X with W2X in Table X1 to specify the all-copper 01502X lug.
- N19. W0X indicates that the part number includes a 01600X universal aluminum compression lug, which is rated for either aluminum or copper, as standard. For an all-copper lug, replace W0X with W2X in Table X1 to specify the all-copper 01602X lug.
- N20. W0X indicates that the part number includes a 01400X universal aluminum compression lug, which is rated for either aluminum or copper, as standard. For an all-copper lug, replace W0X with W2X in Table X1 to specify the all-copper 01402X lug.
- N21. W0X indicates that the part number includes a 01300X universal aluminum compression lug, which is rated for either aluminum or copper, as standard. For an all-copper lug, replace W0X with W2X in Table X1 to specify the all-copper 01302X lug.
- N22. Direct Test Connectors, along with a 200TC-X series meter adapter, a properly rated voltage meter and Hot-line Stick provides a means for direct conductor voltage testing. See page 7 for meter adapters.
- N23. Gains approximately 4" of repair length.

Refer to the **W** and **X** tables on pages 38 and 39 for sizing to cable insulation diameter and conductor size.

For cable shield adapters and jacket seals, see page 28.

600 Series deadbreak elbows, straight receptacles, junctions, vault stretchers and accessories are used to connect equipment and cable on primary feeder and network circuits. Designs accommodate large conductors and feature bolted connections and deadfront modular construction for maximum reliability, performance and versatility.

DE-ENERGIZED connectors can be quickly and easily connected and disconnected using standard hand tools and equipment in accordance with accepted operating practices. Optional accessories allow visible external separation, by-pass, isolation, dead-ending, grounding, and testing as well as adding taps, surge arresters and circuit protection.

Hotstick operable and separable joint systems are shown on pages 14 thru 19.

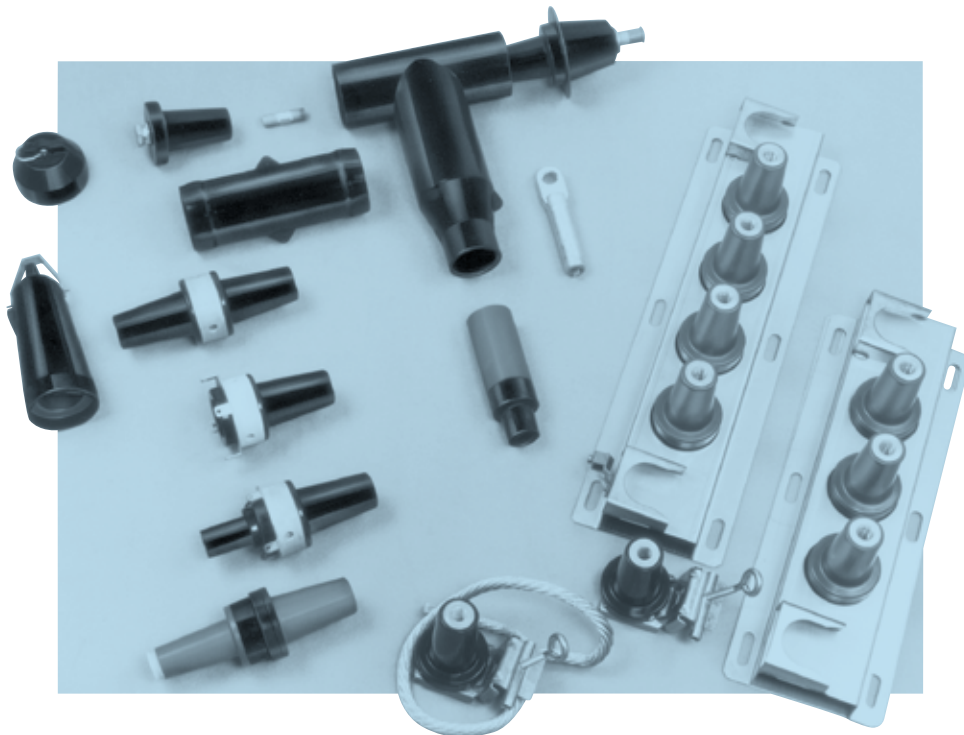

### SEPARABLE CONNECTORS 600 SERIES DEADBREAK

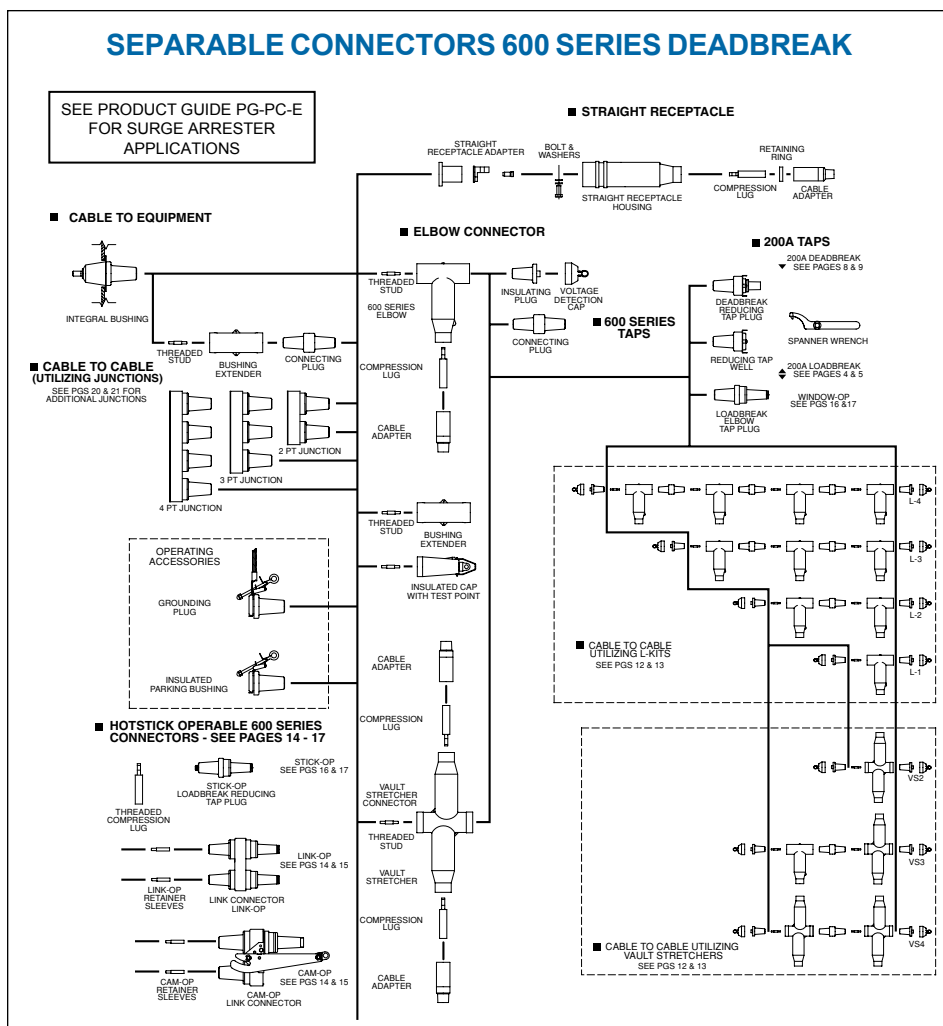

### RATINGS OVERVIEW

See page 2 for complete information.

#### CURRENT RATINGS

(Prefixes: 650, K650, K655, K656, 750, 755, 756 & 03700)

600 Amp Continuous  
 25kA sym., 10 cycles

(Prefixes 675, K675, K676, 775, 776 & 03702)

900 Amp Continuous  
 25kA sym., 10 cycles

NOTE: 900 Amp ratings require copper cable and copper current-carrying components.

#### VOLTAGE RATINGS

15/25kV Class (5kV thru 28kV)

16.2kV Phase-to-Ground

28kV Phase-to-Phase

140kV BIL

45kV AC Withstand

84kV DC Withstand

21.5kV Corona Extinction

#### 35kV Class

21.1kV Phase-to-Ground

36.6kV Phase-to-Phase

150kV BIL

50kV AC Withstand

103kV DC Withstand

26kV Corona Extinction

Note: Elastimold has increased the IEEE Standard Production and Design Test levels for 25kV Class products to include 27kV and 28kV systems.

Illustration (not to scale)	Description	Voltage Class	ELASTIMOLD Part Number	Notes
	600 Series Elbow (w/ Insul. Plug, Cap, Stud, Lug and Cable Adapter)	15/25kV 35kV	<b>K655LR-W0X</b> Use Tables W7 and X6 <b>755LR-W0X</b> Use Tables W9 and X6	N1,2,12 N1,2,12
	600 Series Direct Test Elbow (w/ Insul. Plug, Cap, Stud Lug and Cable Adapter)	15/25kV 35kV	<b>K655DLR-W0X</b> <b>755DLR-W0X</b>	N1,2,12,14 N1,2,12,14
	600 Series Elbow w/ Test Point (w/ Insul. Plug, Cap, Stud, Lug and Cable Adapter)	15/25kV 35kV	<b>K656LR-W0X</b> Use Tables W7 and X6 <b>756LR-W0X</b> Use Tables W9 and X6	N1,2,12 N1,2,12
	600 Series Direct Test Elbow w/ Test Point (w/ Insul. Plug, Cap, Stud, Lug and Cable Adapter)	15/25kV 35kV	<b>K656DLR-W0X</b> Use Tables W7 and X6 <b>756DLR-W0X</b> Use Tables W9 and X6	N1,2,12,14 N1,2,12,14
	600 Series Elbow Housing only (w/ Stud)	15/25kV 35kV	<b>K655BLR</b> <b>755BLR</b>	N1,3 N1,3
	600 Series Elbow w/ Test Point Housing only (w/ Stud)	15/25kV 35kV	<b>K656BLR</b> <b>756BLR</b>	N1,3 N1,3
	600 Series Replacement Elbow Housing only w/o Test Point	15/25kV	<b>K655BRLR</b>	N,16
	600 Series Replacement Elbow Housing only w/ Test Point	15/25kV	<b>K656BRLR</b>	N,16
	600 Series Straight Receptacle (w/ Cable Adapter, Lug & Retaining Ring)	15/25kV	<b>K655SR-W0X</b> Use Tables W7 and X6	N1,2,11
	600 Series Direct Test Straight Receptacle Elbow	15/25kV	<b>K655DSR-W0X</b> Use Tables W7 and X6	N1,2,11,14
	600 Series Straight Receptacle Housing (Lug & Cable Adapter not included)	15/25kV	<b>K655BSR</b>	N1,11
	Straight Receptacle Adapter	15/25kV	<b>K650SRA</b>	N1,4
	600 Series Vault Stretcher (Housing only w/ Stud)	15/25kV 35kV	<b>K655BVS</b> <b>755BVS</b>	N1,9 N1,9
	Cable Size Adapter	15/25kV 35kV	<b>655CA-W</b> Use Table W7 <b>755CA-W</b> Use Table W9	
	Compression Lug	ALL ALL	<b>03700X</b> Use Table X6 <b>03702X</b> Use Table X6	N5 N6
	600 Series Elbow & Vault Stretcher Size Sensitive Kit (Cable Adapter & Lug)	15/25kV 35kV	<b>655CK-W0X</b> Use Tables W7 and X6 <b>755CK-W0X</b> Use Tables W9 and X6	N2 N2
	Adapter Retaining Ring	ALL	<b>650ARR-X</b> Use Table X6	
	600 Series Straight Receptacle Size Sensitive Kit (Cable Adapter, Retaining Ring & Lug)	15/25kV	<b>655CK-W0X-ARR</b> Use Tables W7 and X6	N2
	Bushing Extender (w/ Stud)	15/25kV 35kV	<b>K655BE</b> <b>755BE</b>	N1,3 N1,3
	Insulated Cap w/ Test Point (w/ Stud)	15/25kV	<b>K656DR</b>	N3,7
	Insulating Plug (w/ Cap)	15/25kV 35kV	<b>K650BIP</b> <b>750BIP</b>	N1,7,8 N1,7,8

Illustration (not to scale)	Description	Voltage Class	ELASTIMOLD Part Number	Notes
	Grounding Plug (Ground Lead 2/0 AWG x 30")	15/25kV 35kV	<b>650GP</b> <b>750GP</b>	N1,7,8 N1,7,8
	Insulated Parking Bushing	15/25kV 35kV	<b>K650SOP</b> <b>750SOP</b>	N7,8 N7,8
	Connecting Plug	15/25kV 15/25kV 35kV	<b>K650CP</b> <b>K651CP</b> <b>750CP</b>	N1,7,8,9,13 N1,7,8,10 N1,7,8,10
	Deadbreak Reducing Tap Plug	15/25kV	<b>K650RTP</b>	N1,7,8,9
	Reducing Tap Well	15/25kV	<b>K650RTW</b>	N1,7,8,9
	Loadbreak Elbow Tap Plug	15kV 25kV 35kV	<b>650ETP</b> <b>K650ETP</b> <b>750ETP</b>	N1,7,8,10,12 N1,7,8,10,12 N1,7,8,10,12
	Vault Stretcher Threaded Stud	15/25kV 35kV	<b>650VSA</b> <b>750VSA</b>	N1 N1
	600 Series Elbow Threaded Stud	15/25kV 35kV	<b>650SA</b> <b>750SA</b>	N1 N1
	Assembly Tool (Window-Op)	ALL	<b>600ATM</b>	N12
	Spanner Wrench	ALL	<b>600SW</b>	N9
	Direct Voltage Test Meter Adapter for: <i>HD Electric Meters</i> <i>Ross Meters</i> <i>Chance Meters</i>	ALL	<b>200TC-1</b> <b>200TC-2</b> <b>200TC-4</b>	N14 N14 N14

- N1. For 900 Amp ratings, substitute 675 for 650 and 655; 676 for 656; K671 for K651; K675 for K650 and K655; K676 for K656; 775 for 750 and 755; 776 for 756 and 2X for 0X in the part number. The 900 Amp rating requires copper current-carrying connector components and copper conductor cable.
- N2. Add suffix symbol from page 29 to include cable shield grounding kit and/or cable jacket sealing kit.
- N3. Available without the stud by adding "N" to the part number.
- N4. Straight Receptacle Adapter is used to connect Straight Receptacles K655YBSR and K655YSR-W0X (Pg.19) to equipment bushings.
- N5. Aluminum lug for use on aluminum or copper conductors. DO NOT substitute threaded 03600X lug.
- N6. Copper lug for use on COPPER CONDUCTOR ONLY. DO NOT substitute threaded 03602X lug.
- N7. Available with the stud factory-assembled by adding "SP" to the part number. 675ETP, K675ETP and 775ETP are available as -SP only. The stud is not field removable.
- N8. Available with a loose stud by adding suffix "S" to the part number.
- N9. 600SW spanner wrench is recommended for installation of K650CP connecting plug, deadbreak reducing tap plugs and reducing tap wells.
- N10. Use 600ATM Assembly Tool.
- N11. 600 Series Elbows and Straight Receptacles with IEEE Std. 386 capacitive test points are available by substituting 656 for 655; K656 for K655; K676 for K675; 756 for 755; 676 for 675; K676 for K675 and 776 for 775 in the part number.
- N12. See page 17 for Window-Op Connector Kit.
- N13. Superseded by K651CP.
- N14. Direct Test Connectors, along with a 200TC-X series meter adapter, a properly rated voltage meter and Hot-line Stick; provides a means for direct conductor voltage testing.
- N15. With stainless steel bracket.
- N16. Replacement Elbow includes an I-Adapter, and Straight Receptacle, resulting in a net gain of 20".

Refer to the **W** and **X** tables on pages 38 and 39 for sizing to cable insulation diameter and conductor size.  
For cable shield adapters and jacket seals, see page 28.

600 Series deadbreak elbows, straight receptacles, junctions, vault stretchers and accessories are used to connect equipment and cable on primary feeder and network circuits. Designs accommodate large conductors and feature bolted connections and deadfront modular construction for maximum reliability, performance and versatility.

DE-ENERGIZED connectors can be quickly and easily connected and disconnected using standard hand tools and equipment in accordance with accepted operating practices. Optional accessories allow visible external separation, by-pass, isolation, dead-ending, grounding, and testing as well as adding taps, surge arresters and circuit protection.

Hotstick operable and separable joint systems are shown on pages 14 thru 19.

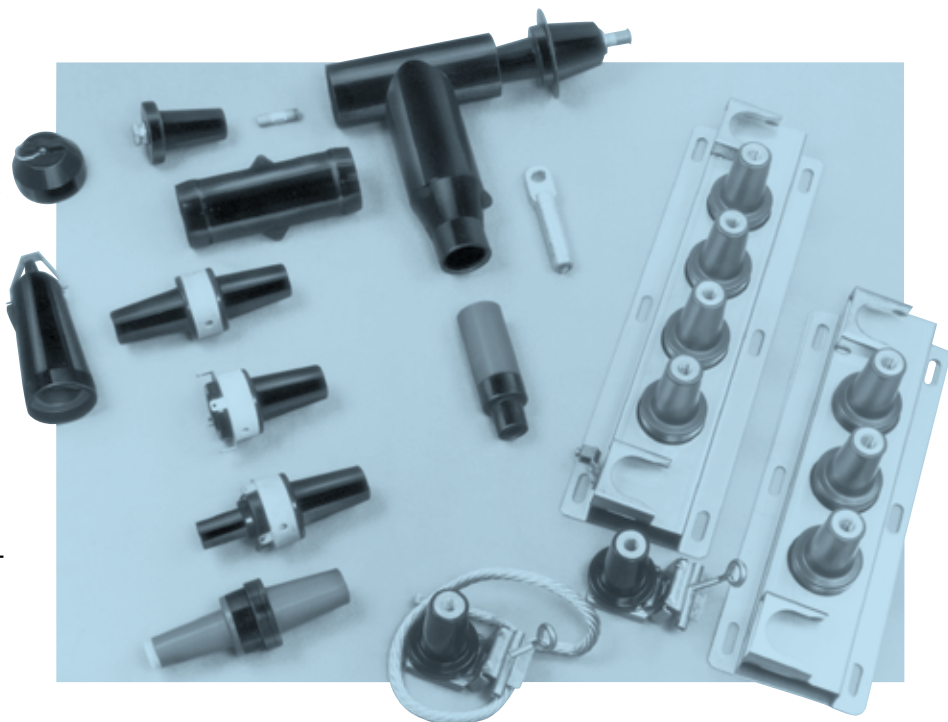

### RATINGS OVERVIEW

See page 2 for complete information.

#### CURRENT RATINGS

(Prefixes: 650, K650, K655, K656, 750, 755, 756 & 03700)

600 Amp Continuous  
25kA sym., 10 cycles

(Prefixes 675, K675, K676, 775, 776 & 03702)

900 Amp Continuous  
25kA sym., 10 cycles

NOTE: 900 Amp ratings require copper cable and copper current-carrying components.

#### VOLTAGE RATINGS

15/25kV Class (5kV thru 28kV)

16.2kV Phase-to-Ground

28kV Phase-to-Phase

140kV BIL

45kV AC Withstand

84kV DC Withstand

21.5kV Corona Extinction

#### 35kV Class

21.1kV Phase-to-Ground

36.6kV Phase-to-Phase

150kV BIL

50kV AC Withstand

103kV DC Withstand

26kV Corona Extinction

Note: Elastimold has increased the IEEE Standard Production and Design Test levels for 25kV Class products to include 27kV and 28kV systems.

### SEPARABLE CONNECTORS 600 SERIES DEADBREAK

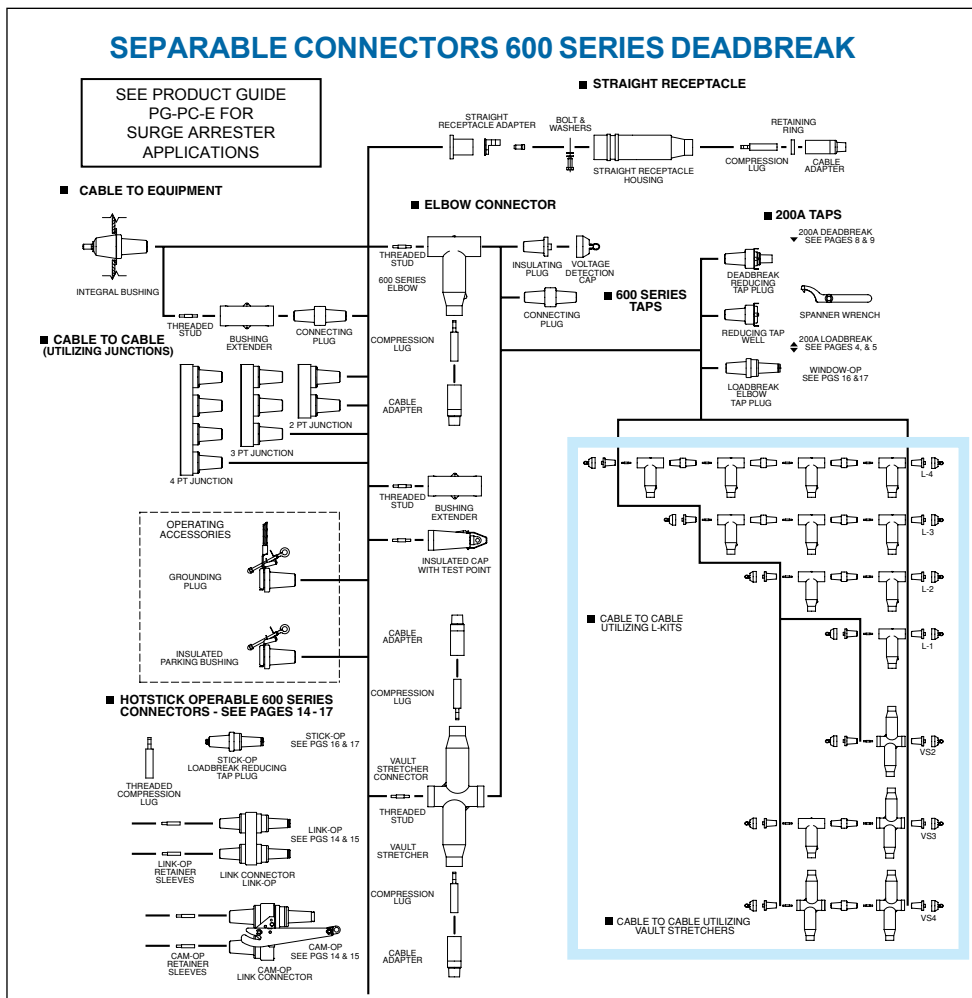



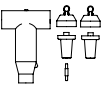
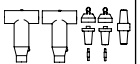

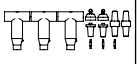
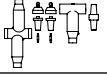

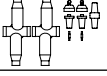

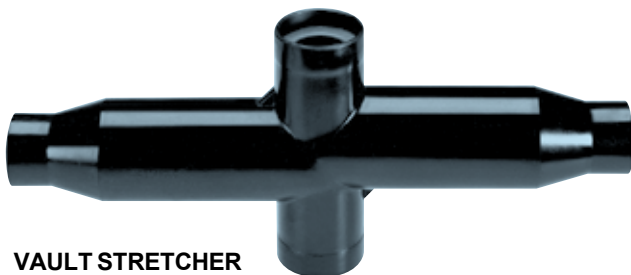

Illustration (not to scale)	Description	Voltage Class	ELASTIMOLD Part Number	Notes
	2-Point Junction	15/25kV 35kV	<b>K650J2</b> <b>750J2</b>	N1,9,10 N1,9,10
	3-Point Junction	15/25kV 35kV	<b>K650J3</b> <b>750J3</b>	N1,9,10 N1,9,10
	4-Point Junction	15/25kV 35kV	<b>K650J4</b> <b>750J4</b>	N1,9,10 N1,9,10
	1-way L-Kit	15/25kV 35kV	<b>K655L1</b> <b>755L1</b>	N1,2,3,4 N1,2,3,4
	2-way L-Kit	15/25kV 35kV	<b>K655L2</b> <b>755L2</b>	N1,2,3,4,5,6,7 N1,2,3,4,5,6,7
	2-way VS-Kit	15/25kV 35kV	<b>K655VSL2</b> <b>755VSL2</b>	N1,2,3 N1,2,3
	3-way L-Kit	15/25kV 35kV	<b>K655L3</b> <b>755L3</b>	N1,2,3,4,5 N1,2,3,4,5
	3-Way VS Kit	15/25kV 35kV	<b>K655VSL3</b> <b>755VSL3</b>	N1,2,3,5,6,7 N1,2,3,5,6,7
	4-Way L-Kit	15/25kV 35kV	<b>K655L4</b> <b>755L4</b>	N1,2,3,4,5 N1,2,3,4,5
	4-Way VS-Kit	15/25kV 35kV	<b>K655VSL4</b> <b>755VSL4</b>	N1,2,3,5 N1,2,3,5
	Assembly Tool (Window-Op)	ALL	<b>600ATM</b>	N8
	Spanner Wrench	ALL	<b>600SW</b>	N2

- N1. For 900 Amp ratings, substitute 675 for 650 and 655; 676 for 656; K675 for K650 and K655; K676 for K656; 775 for 750 and 755; 776 for 756 and 2X for 0X in the part number. The 900 Amp rating requires copper current-carrying connector components and copper conductor cable.
- N2. 600SW spanner wrench is recommended for installation of K650CP connecting plug, deadbreak reducing tap plugs and reducing tap wells.
- N3. L-Kits and VS-Kits do not include cable adapters or compression lugs. These items must be ordered separately.
- N4. 600 Series Elbows and Straight Receptacles with IEEE Std. 386 capacitive test points are available by substituting 656 for 655; K656 for K655; K676 for K675; 756 for 755; 676 for 675; K676 for K675 and 776 for 775 in the part number.
- N5. 600ATM is recommended for installing K651CP and 750CP.
- N6. Can be used as a repair joint. (Gains 3-1/2" of repair length)
- N7. Can be used as a reducing joint for different size cables.
- N8. See page 17 for Window-Op Connector Kit.
- N9. Rubber junction with stainless steel mounting plate and back plate. Add "-U" for rubber junction with stainless steel mounting plate, back plate and adjustable mounting bracket. Add "-4" for rubber junction only. Add "-5" for rubber junction, stainless steel U-straps and back plate.
- N10. Two - six-position multi-point junctions shown on pages 20 and 21.



### VAULT STRETCHER

Provides an alternate method of splicing and joining various types and styles of cables using standard 600 Series components.

Refer to the **W** and **X** tables on pages 38 and 39 for sizing to cable insulation diameter and conductor size.

For cable shield adapters and jacket seals, see page 28.

Elastimold's 600 Series Cam-Op™, and Link-Op™ deadbreak connector systems incorporate provisions for hotstick operation of DE-ENERGIZED primary feeder or network circuits. Configurations allow external visible break, testing, grounding and isolation. Retrofit kits allow upgrading existing equipment.

Cam-Op systems utilize pin and socket connectors. Link-Op connectors are bolted and installed using torque controlled tools. Either system can be retrofitted to existing equipment.

The Cam-Op and Link-Op connectors are unique, allowing all hotstick operations to be completed without moving the cable, an important consideration when large, stiff cables prohibit movement.

The Cam-Op connector is easily installed or removed by hotstick operation of the cam action disconnect lever.

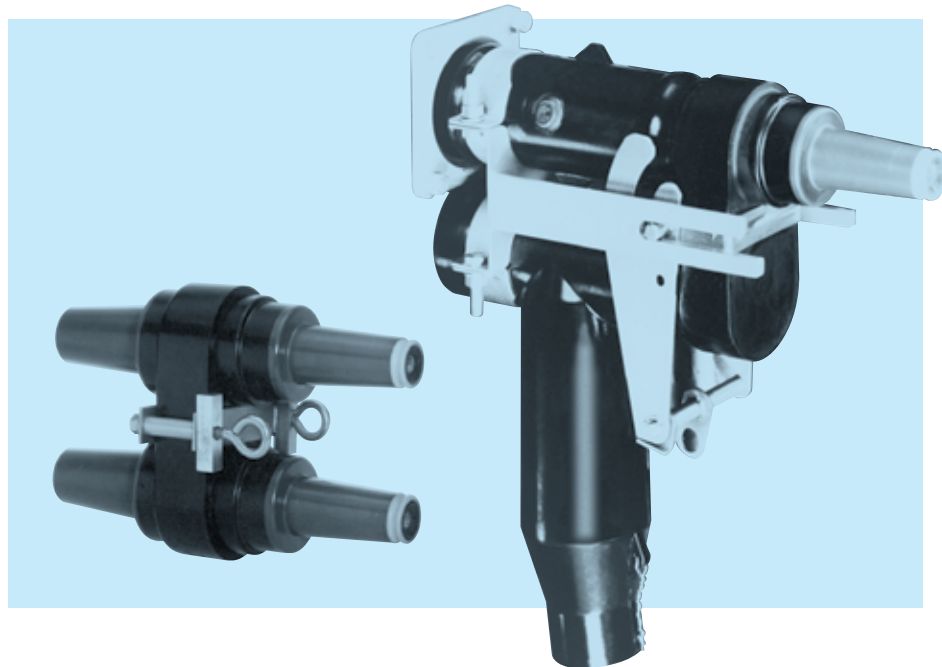

### RATINGS OVERVIEW

See page 2 for complete information.

#### CURRENT RATINGS

600 & 900 Amp Continuous  
25kA sym., 10 cycles

NOTE: 900 Amp ratings require copper cable and copper current-carrying components.

#### CONTINUOUS VOLTAGE RATINGS

**15kV Class**  
8.3kV Phase-to-Ground  
14.4kV Phase-to-Phase  
95kV BIL  
34kV AC Withstand  
53kV DC Withstand  
11kV Corona Extinction

**25kV Class**  
15.2kV Phase-to-Ground  
26.3kV Phase-to-Phase  
125kV BIL  
40kV AC Withstand  
78kV DC Withstand  
19kV Corona Extinction

**35kV Class**  
21.1kV Phase-to-Ground  
36.6kV Phase-to-Phase  
150kV BIL  
50kV AC Withstand  
103kV DC Withstand  
26kV Corona Extinction

### CAM-OP™ & LINK-OP™ SYSTEM – 600 SERIES DEADBREAK

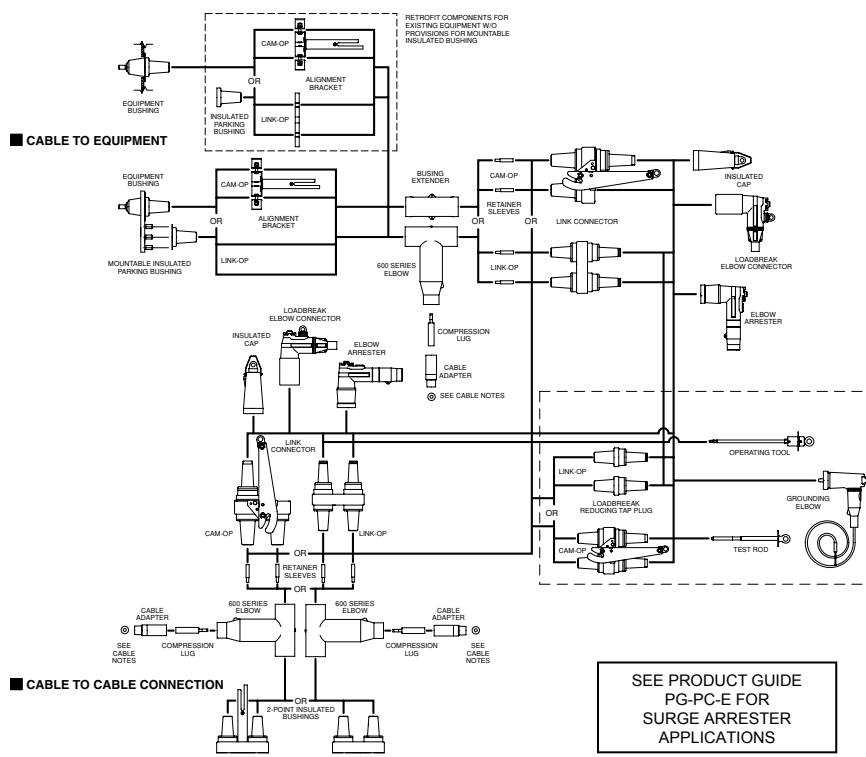

Separable Connectors  
600 Ser. DB (Cam-Op, Link-Op)

Illustration (not to scale)	Description	Voltage Class	ELASTIMOLD Part Number	Notes
	CAM-OP CONNECTOR KIT	15kV 25kV 35kV	<b>655LINK-C-LR-W0X-B-DRG</b> Use Tables W7 and X6 <b>K655LINK-C-LR-W0X-B-DRG</b> Use Tables W7 and X6 <b>755LINK-C-LR-W0X-B-DRG</b> Use Tables W9 and X6	N1,3,11, 13,14,18 N1,3,11, 13,14,18 N1,3,11, 13,14,18
	LINK-OP CONNECTOR KIT	15kV 25kV 35kV	<b>655LINK-B-LR-W0X-B-DRG</b> Use Tables W7 and X6 <b>K655LINK-B-LR-W0X-B-DRG</b> Use Tables W7 and X6 <b>755LINK-B-LR-W0X-B-DRG</b> Use Tables W9 and X6	N2,3,11,12 13,14,18 N2,3,11, 13,14,18 N2,3,11, 13,14,18
	Mountable Insulated Bushing	25kV 35kV	<b>K650LBM-3</b> <b>750LBM-3</b>	N3 N3
	RETROFIT CAM-OP CONNECTOR KIT	15kV 25kV 35kV	<b>655LINK-C-LR-W0X-A-DRG</b> Use Tables W7 and X6 <b>K655LINK-C-LR-W0X-A-DRG</b> Use Tables W7 and X6 <b>755LINK-C-LR-W0X-A-DRG</b> Use Tables W9 and X6	N5,11,13 14,18 N5,11,13 14,18 N5,11,13 14,18
	RETROFIT LINK-OP CONNECTOR KIT	15kV 25kV 35kV	<b>655LINK-B-LR-W0X-A-DRG</b> Use Tables W7 and X6 <b>K655LINK-B-LR-W0X-A-DRG</b> Use Tables W7 and X6 <b>755LINK-B-LR-W0X-A-DRG</b> Use Tables W9 and X6	N6,11,12, 13,14,18 N6,11,12, 13,14,18 N6,11,12, 13,14,18
	Insulating Plug	25kV 35kV	<b>K650LB</b> <b>750LB</b>	N4 N4
	CAM-OP Alignment Bracket	15kV 25kV 35kV	<b>650CAB</b> <b>K650CAB</b> <b>750CAB</b>	
	LINK-OP Alignment Bracket (Retrofit LINK-OP Only)	ALL ALL	<b>650AB</b> <b>650ABV</b>	N15 N15
	Compression Lug	ALL ALL	<b>03700X</b> Use Table X6 <b>03702X</b> Use Table X6	N7 N8
	CAM-OP & LINK-OP Size Sensitive Kit (Cable Adapter & Lug)	15/25kV 35kV	<b>655CK-W0X</b> Use Tables W7 and X6 <b>755CK-W0X</b> Use Tables W9 and X6	N13 N13
	CAM-OP Retaining Sleeve	ALL	<b>650RSC</b>	N11
	LINK-OP Retaining Sleeve	ALL	<b>650RS</b>	N11
	CAM-OP CABLE JOINT KIT	15kV 25kV 35kV	<b>655BI-LINK-C-LR-W0X-DRG</b> Use Tables W7 and X6 <b>K655BI-LINK-C-LR-W0X-DRG</b> Use Tables W7 and X6 <b>755BI-LINK-C-LR-W0X-DRG</b> Use Tables W9 and X6	N9,11,13 14,18 N9,11,13 14,18 N9,11,13 14,18
	LINK-OP CABLE JOINT KIT	15kV 25kV 35kV	<b>655BI-LINK-B-LR-W0X-DRG</b> Use Tables W7 and X6 <b>K655BI-LINK-B-LR-W0X-DRG</b> Use Tables W7 and X6 <b>755BI-LINK-B-LR-W0X-DRG</b> Use Tables W9 and X6	N10,11,12, 13,14,18 N10,11,12, 13,14,18 N10,11,12, 13,14,18
	CAM-OP Loadbreak Reducing Tap Plugs (Visi-Break)	15kV 25kV 35kV	<b>650LK-C-VB</b> <b>K650LK-C-VB</b> <b>750LK-C-VB</b>	
	LINK-OP Loadbreak Reducing Tap Plug	15kV 25kV 35kV	<b>650LT-B</b> <b>K650LT-B</b> <b>750LT-B</b>	N11

Illustration (not to scale)	Description	Voltage Class	ELASTIMOLD Part Number	Notes
	Grounding Elbow (1/0 AWG x 6' Ground Lead)	15kV 25kV 35kV	<b>160GLR</b> <b>370GLR</b> <b>370GLR</b>	N19 N19
	Test Rod	ALL	<b>370TR</b>	
	Assembly Tool	ALL	<b>600AT</b>	N11
	CAM-OP OPERATING KIT	15kV 25kV 35kV	<b>650CAM-OK</b> <b>K650CAM-OK</b> <b>750CAM-OK</b>	N16 N16 N16
	LINK-OP OPERATING KIT	15kV 25kV 35kV	<b>650LINK-OK</b> <b>K650LINK-OK</b> <b>750LINK-OK</b>	N17 N17 N17

- N1. Cam-Op connector kit includes: 1- Cam-Op link; 1- elbow housing; 1- cable adapter; 1-0370 style lug; 1- bushing extender; 2- retainer sleeves; 1- insulated cap; 1- mountable insulated bushing and 1- alignment bracket.
- N2. Link-Op connector kit includes: 1- Link-Op link; 1- elbow housing; 1- cable adapter; 1-0370 style lug; 1- bushing extender; 2- retainer sleeves; 2- insulated caps; and 1- mountable insulated bushing.
- N3. Mountable insulated bushing included with Cam-Op and Link-Op connector kit. Requires 3 threaded studs on equipment faceplate for installation.
- N4. Use with the Retrofit Cam-Op and Retrofit Link-Op connector kit.
- N5. Retrofit Cam-Op connector kit includes: 1- link; 1- elbow housing; 1- cable adapter; 1-0370 style lug; 1- bushing extender; 2- retainer sleeves; 1- insulated cap; 1- insulating plug; and 1- alignment bracket.
- N6. Retrofit Link-Op connector kit includes: 1- link; 1- elbow housing; 1- cable adapter; 1-0370 style lug; 1- bushing extender; 2- retainer sleeves; 2- insulated caps; 1- insulating plug; and 1- alignment bracket.
- N7. Aluminum lug for use on aluminum or copper conductors. DO NOT substitute threaded 03600X lug.
- N8. Copper lug for use on COPPER CONDUCTOR ONLY. DO NOT substitute 03602X threaded lug.
- N9. Cam-Op Cable Joint Kit includes: 1- Cam-Op link; 1- Cam-Op BI-SOP; 2- elbow housings; 2- cable adapters; 2- 0370 style lugs; 2- retainer sleeves; 1- insulated cap.
- N10. Link-Op Cable Joint Kit includes: 1- Link-Op link; 1- Link-Op BI-SOP; 2- elbow housings; 2- cable adapters; 2- 0370 style lugs; 2- retainer sleeves; 2- insulated caps.
- N11. 600AT assembly tool required for operation and/or installation of Link-Op. 600ATM is recommended for installing Link-Op/Cam-Op retaining sleeves.
- N12. For 900 Amp ratings, substitute 675 for 650 and 655; 676 for 656; K675 for K650 and K655; K676 for K656; 775 for 750 and 755; 776 for 756 and 2X for 0X in the part number. The 900 Amp rating requires copper current-carrying connector components and copper conductor cable.
- N13. Add suffix symbol from page 29 to include cable shield grounding kit and/or cable jacket sealing kit.
- N14. To add elbows or arresters instead of insulating caps, replace the "DRG" with "LR-WX" for elbows (with test point) or "ESA" for elbow arresters.
- N15. The 650ABV is required when the bushing horizontal spacing on the equipment or junctions is less than 5".
- N16. Cam-Op operating kit includes accessories that enable visible break, testing, isolation and grounding functions to be performed. Kit includes: 3- Cam-Op loadbreak reducing tap plugs; 3- grounding elbows; 1- assembly tool; 1- test rod; 1- carry case; 1- lubricant; 1- instructions.
- N17. Link-Op operating kit includes accessories that enable visible break, testing, isolation and grounding functions to be performed. Kit includes: 6- Link-Op loadbreak reducing tap plugs; 3- grounding elbows; 1- assembly tool; 1- test rod; 1- carry case; 1- lubricant; 1- instructions.
- N18. 600 Series Elbows and Straight Receptacles with IEEE Std. 386 capacitive test points are available by substituting 656 for 655; K656 for K655; K676 for K675; 756 for 755; 676 for 675; K676 for K675 and 776 for 775 in the part number.
- N19. Rated for both 25kV and 35kV applications.

Refer to the **W** and **X** tables on pages 38 and 39 for sizing to cable insulation diameter and conductor size.

For cable shield adapters and jacket seals, see page 28.

Elastimold's 600 Series Window-Op™ and Stick-Op™ deadbreak connector systems incorporate provisions for hotstick operation of DE-ENERGIZED primary feeder or network circuits.

The Window-Op and Stick-Op connectors allow direct testing and grounding with no required cable movement.

Window-Op is ideal for equipment applications which include viewing windows to provide an internal visible break that does not require hotstick removal of the elbows.

Stick-Op provides an external visible break by hotstick removal of the elbow.

Window-Op and Stick-Op connectors are bolted and installed using torque controlled tools.

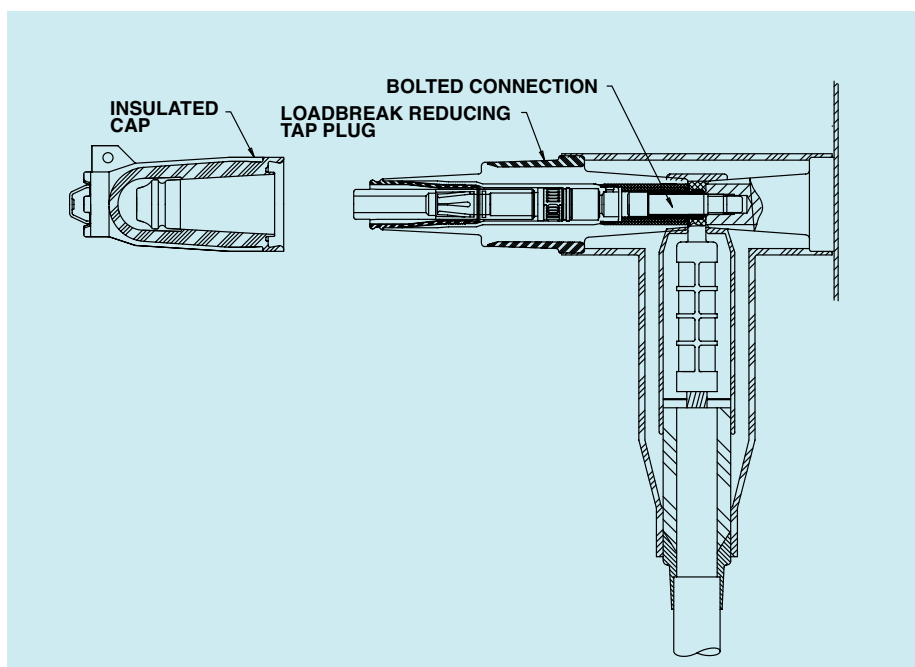

### RATINGS OVERVIEW

See page 2 for complete information.

#### CURRENT RATINGS

600 & 900 Amp Continuous  
25kA sym., 10 cycles

NOTE: 900 Amp ratings require copper cable and copper current-carrying components.

#### CONTINUOUS VOLTAGE RATINGS

##### 15kV Class

8.3kV Phase-to-Ground  
14.4kV Phase-to-Phase  
95kV BIL  
34kV AC Withstand  
53kV DC Withstand  
11kV Corona Extinction

##### 25kV Class

15.2kV Phase-to-Ground  
26.3kV Phase-to-Phase  
125kV BIL  
40kV AC Withstand  
78kV DC Withstand  
19kV Corona Extinction







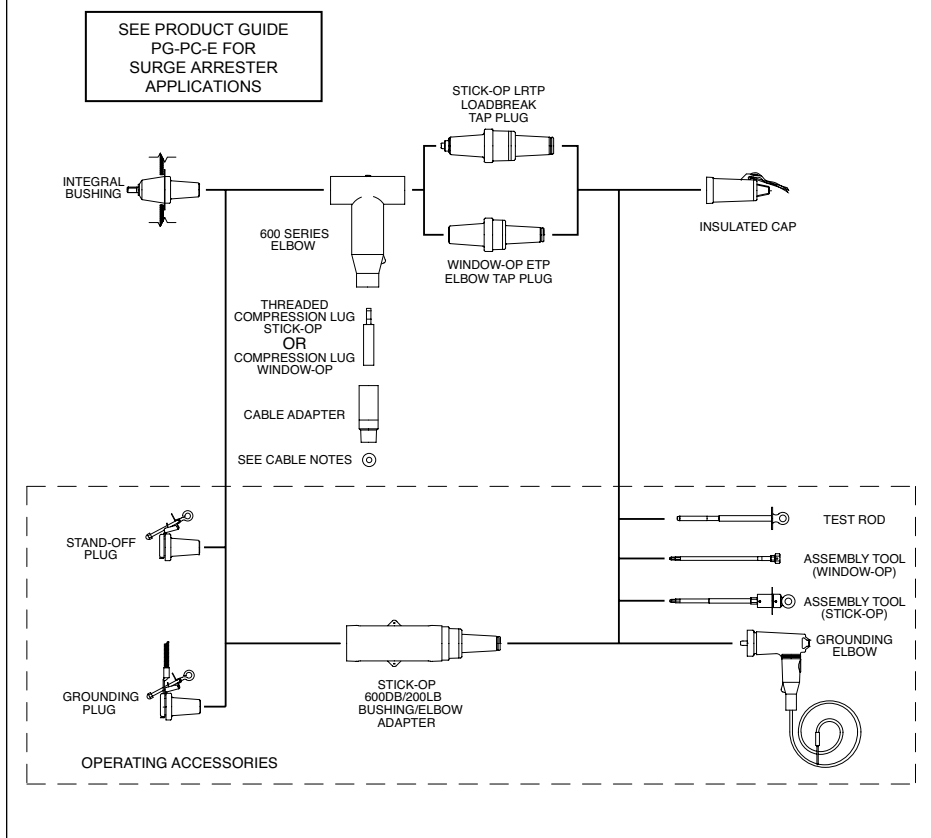

##### 35kV Class

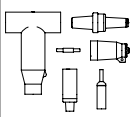
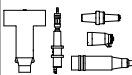
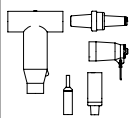
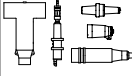
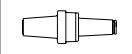
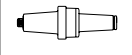
21.1kV Phase-to-Ground  
36.6kV Phase-to-Phase  
150kV BIL  
50kV AC Withstand  
103kV DC Withstand  
26kV Corona Extinction

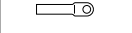
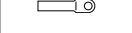
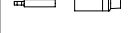
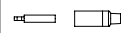
### STICK-OP™ & WINDOW-OP™ SYSTEM – 600 SERIES DEADBREAK

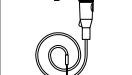
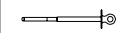

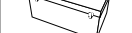
Separable Connectors  
600 Ser. DB (Stick-Op, Window-Op)

Illustration (not to scale)	Description	Voltage Class	ELASTIMOLD Part Number	Notes
	WINDOW-OP Connector Kit	15kV 25kV 35kV	<b>655ETP-W0X-DRG</b> Use Tables W7 and X6 <b>K655ETP-W0X-DRG</b> Use Tables W7 and X6 <b>755ETP-W0X-DRG</b> Use Tables W9 and X6	N1,4,5,6 13,15
	WINDOW-OP Replacement Connector Kit	15kV 25kV	<b>655RETP</b>  <b>K655RETP</b>	N4,5,6 13,15,16
	STICK-OP Connector Kit	15kV 25kV 35kV	<b>655LRTP-W0X-DRG</b> Use Tables W7 and X6 <b>K655LRTP-W0X-DRG</b> Use Tables W7 and X6 <b>755LRTP-W0X-DRG</b> Use Tables W9 and X6	N2,3,4,5, 8,13
	STICK-OP Replacement Connector Kit	15kV 25kV	<b>655RLRTP</b>  <b>K655RLRTP</b>	N3,4,5 8,13,16
	WINDOW-OP Loadbreak Elbow Tap Plug	15kV 25kV 35kV	<b>650ETP</b> <b>K650ETP</b> <b>750ETP</b>	N4,15 N4,15 N4,15
	STICK-OP Loadbreak Reducing Tap Plug	15kV 25kV 35kV	<b>650LRTPA3</b> <b>K650LRTPA2</b> <b>750LRTPA2</b>	N3,4
	STICK-OP Bushing Adapter	15kV 25kV 35kV	<b>650BEA3</b> <b>K650BEA2</b> <b>750BEA2</b>	N3,4
	Compression Lug WINDOW-OP	ALL	<b>03700X</b> Use Tables X6 <b>03702X</b> Use Tables X6	N6 N7
	Threaded Compression Lug STICK-OP	ALL	<b>03600X</b> Use Tables X6 <b>03602X</b> Use Tables X6	N8 N9
	WINDOW-OP Size Sensitive Kit (Cable Adapter & Lug)	15/25kV 35kV	<b>655CK-W0X</b> Use Tables W7 and X6 <b>755CK-W0X</b> Use Tables W9 and X6	N5 N5
	STICK-OP Size Sensitive Kit (Cable Adapter & Threaded Lug)	15/25kV 35kV	<b>655TCK-W0X</b> Use Tables W7 and X6 <b>755TCK-W0X</b> Use Tables W9 and X6	N5 N5
	Extraction Tool	ALL	<b>650ET</b>	N10
	Grounding Elbow (1/0 AWG x 6' Ground Lead)	15kV 25kV 35kV	<b>160GLR</b> <b>370GLR</b> <b>370GLR</b>	N14 N14
	Test Rod	ALL	<b>370TR</b>	
	Assembly Tool (Stick-Op)	ALL	<b>600AT</b>	N3
	Assembly Tool (Window-Op)	ALL	<b>600ATM</b>	N15
	STICK-OP OPERATING KIT	15kV 25kV 35kV	<b>650STICK-OK</b> <b>K650STICK-OK</b> <b>750STICK-OK</b>	N11 N11 N11
	WINDOW-OP OPERATING KIT	15kV 25kV 35kV	<b>650WINDOW-OK</b> <b>K650WINDOW-OK</b> <b>750WINDOW-OK</b>	N12 N12 N12

- N1. Window-Op Kit includes: insulated cap; Window-Op reducing tap plug; 600 Series elbow housing; cable adapter; and 0370 style compression lug.
- N2. Stick-Op Kit includes insulated cap; Stick-Op Loadbreak reducing tap plug; 600A Elbow Housing; cable adapter; and threaded 0360 style compression lug.
- N3. 600AT assembly tool required for operation and/or installation of Stick-Op.
- N4. For 900 Amp ratings, substitute 675 for 650 and 655; 676 for 656; K675 for K650 and K655; K676 for K656; 775 for 750 and 755; 776 for 756 and 2X for 0X in the part number. The 900 Amp rating requires copper current-carrying connector components and copper conductor cable.
- N5. Add suffix symbol from page 29 to include cable shield grounding kit and/or cable jacket sealing kit.
- N6. Aluminum lug for use on aluminum or copper conductors. DO NOT substitute threaded 03600X lug.
- N7. Copper lug for use on COPPER CONDUCTOR ONLY. DO NOT substitute 03602X threaded lug.
- N8. Threaded aluminum lug (Stick-Op only) for use on copper or aluminum conductors. DO NOT substitute unthreaded 03700X lugs. DO NOT use with 675, 676, K675, K676, 775 or 776 part numbers.
- N9. Threaded copper lug (Stick-Op only) for use on copper conductors only. DO NOT substitute unthreaded 03702X lugs.
- N10. Required to disassemble Stick-Op loadbreak reducing tap plug from the threaded compression lug and 600 Series elbow after the shear-pin is broken during assembly.
- N11. Stick-Op Operating Kit includes accessories that enable visible break direct testing, isolation, and grounding functions to be performed. Kit includes: 3-insulated parking bushings; 3-grounding elbows; 3-600DB/200LB bushing/elbow adapters; 1-assembly tool; 1-test rod; 1-carry case; 1-lubricant; 1-instructions.
- N12. Window-Op Operating Kit includes accessories that enable visible grounding and direct testing functions to be performed. Kit includes: 3-grounding elbows; 1-test rod; 1-carry case; 1-lubricant; 1-instructions.
- N13. 600 Series Elbows and Straight Receptacles with IEEE Std. 386 capacitive test points are available by substituting 656 for 655; K656 for K655; K676 for K675; 756 for 755; 676 for 675; K676 for K675 and 776 for 775 in the part number.
- N14. Rated for both 25kV and 35kV applications.
- N15. 600ATM assembly tool required for Window-Op assembly. 50 – 60 ft/lbs torque wrench required but not included.
- N16. Replacement Elbow includes: insulated cap; reducing tap plug; 600 series elbow housing; I-Adapter; straight receptacle, resulting in a net gain of 20" in length vs. a standard elbow kit. Compression lugs and cable adapters are ordered separately.

Refer to the **W** and **X** tables on pages 38 and 39 for sizing to cable insulation diameter and conductor size.

For cable shield adapters and jacket seals, see page 28.

600 Series Separable Cable Joints are available in 2, 3 and 4-way versions and include a capacitive test point as standard. Units are interchangeable, featuring bolted connections. Designs are compact and ideally suited for small vaults and manholes.

DE-ENERGIZED joints can be quickly and easily connected and disconnected using standard hand tools and equipment in accordance with accepted operating practices. Bus bars can be changed to add or remove cables from the joint.

Optional accessories include insulating and grounding caps and plugs which allow visible external separation, by-pass, isolation, dead-ending, grounding and testing.

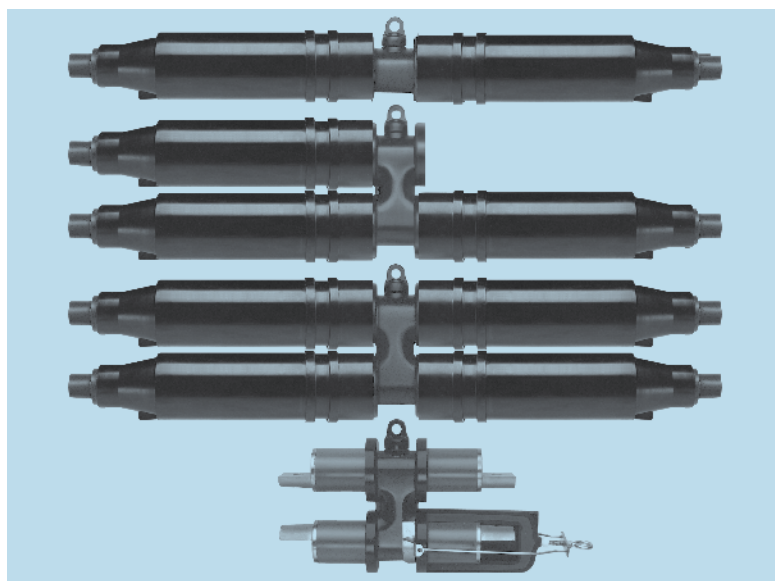

### RATINGS OVERVIEW

See page 2 for complete information

#### CURRENT RATINGS

(Prefixes: 650, K650, K655, K656 & 03700)

600 Amp Continuous

25kA sym., 10 cycles

#### VOLTAGE RATINGS

**15/25kV Class (5kV thru 28kV)**

16.2kV Phase-to-Ground

28kV Phase-to-Phase

140kV BIL

45kV AC Withstand

84kV DC Withstand

21.5kV Corona Extinction

Note: Elastimold has increased the IEEE Standard Production and Design Test levels for 25kV Class products to include 27kV and 28kV systems.

### SEPARABLE CABLE JOINTS – 600 SERIES DEADBREAK

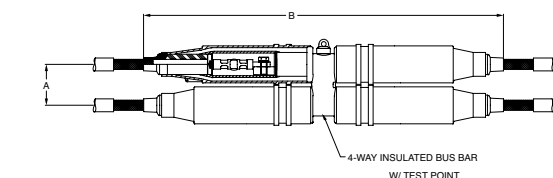

SEPARABLE H-JOINT (4-WAY)

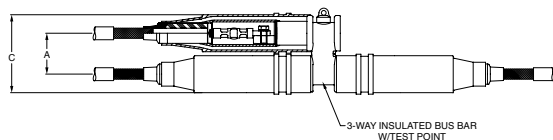

SEPARABLE WYE-JOINT (3-WAY)

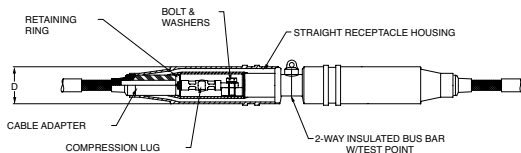

SEPARABLE STRAIGHT JOINT (2-WAY)

#### OPERATING ACCESSORIES

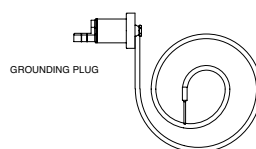
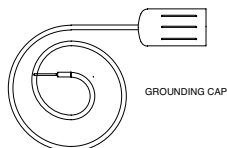
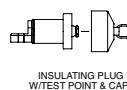
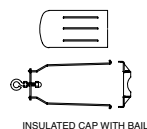

Note: The separable cable joints shown here use a special “Y” interface that may not be interchangeable with other 600 Series interfaces.

DIMENSION	INCHES
A	4 1/4
B	37 1/8
C	8 1/8
D	3 7/8

Illustration (not to scale)	Description	Voltage Class	ELASTIMOLD Part Number	Notes
	Separable Straight Joint Pkg. (2-way) w/ Test Point	15/25kV	<b>K656I-W0X</b> Use Tables W7 and X6	N1,8
	Basic Housing Pkg. Straight Joint w/ Test Point	15/25kV	<b>K656I-HP</b>	N2
	Separable Wye Joint Pkg. (3-Way) w/ Test Point	15/25kV	<b>K656CY-W0X</b> Use Tables W7 and X6	N1,8
	Basic Housing Pkg. Wye Joint w/ Test point	15/25kV	<b>K656CY-HP</b>	N2
	Separable "H" Joint Pkg. (4-Way) w/ Test Point	15/25kV	<b>K656CH-W0X</b> Use Tables W7 and X6	N1,8
	Basic Housing Pkg. "H" Joint w/ Test Point	15/25kV	<b>K656CH-HP</b>	N2
	2-Way Insulated Bus Bar w/Test Point	15/25kV	<b>K656I-BUS</b>	N3
	3-Way Insulated Bus Bar w/Test Point	15/25kV	<b>K656CY-BUS</b>	N3
	4-Way Insulated Bus Bar w/Test Point	15/25kV	<b>K656CH-BUS</b>	N3
	Straight Receptacle	15/25kV	<b>K655YSR-W0X</b> Use Tables W7 and X6	N4,8
	Direct Test Straight Receptacle Elbow	15/25kV	<b>K655YDSR-W0X</b> Use Tables W7 and X6	N4,8,11
	Direct Test Straight Receptacle Elbow w/ Test Point	15/25kV	<b>K656YDSR-W0X</b> Use Tables W7 and X6	N4,8,11
	Straight Receptacle Housing Only	15/25kV	<b>K655YBSR</b>	N5,10
	Insulated Cap w/ Bail	15/25kV	<b>K655YDR</b>	
	Bail Only	15/25kV	<b>650BA</b>	
	Cable Adapter	15/25kV	<b>655CA-W</b> Use Table W7	
	Adapter Retaining Ring	15/25kV	<b>650ARR-X</b> Use Table X6	
	Compression Lug	15/25kV 15/25kV	<b>03700X</b> <b>03702X</b> Use Table X6	N7 N9
	600 Series Straight Receptacle Size Sensitive Kit (Cable Adapter, Retaining Ring & Lug)	15/25kV	<b>655CK-W0X-ARR</b> Use Tables W7 and X6	N8

Illustration (not to scale)	Description	Voltage Class	ELASTIMOLD Part Number	Notes
	Insulating Plug w/ Test Point & Cap	15/25kV	<b>K650YBIP</b>	
	Grounding Plug (4/0 AWG x 6' Ground Lead)	15/25kV	<b>650YGP</b>	
	Grounding Cap (4/0 AWG x 6' Ground Lead)	15/25kV	<b>650GYDR</b>	
	Stainless Steel Bolt & Washers	15/25kV	<b>650BAW</b>	
	Assembly/Disassembly Tool	ALL	<b>600YADT</b>	N6
	Assembly/Disassembly Tool	ALL	<b>600RRT</b>	N6

- N1. Complete Joint Packages consisting of: insulated bus bar; straight receptacle housings, retaining rings, cable size adapters, lugs, bolts and washers.
- N2. Housing Packages consisting of the following non-size sensitive components of the joint: insulated bus bar, straight receptacle housings, bolts and washers.
- N3. Insulated bus bar only.
- N4. Straight Receptacle consisting of: straight receptacle housing, retaining ring, cable adapter, lug, bolt and washers.
- N5. Straight receptacle housing consisting of: straight receptacle housing, bolt and washers.
- N6. Recommended for ease of assembly/disassembly of receptacles to Bus. 600 YADT is lever drive & 600RRT is screw drive.
- N7. Aluminum lug for use on aluminum or copper conductors. DO NOT substitute threaded 03600X lug.
- N8. Add suffix symbol from page 29 to include cable shield grounding kit and/or cable jacket sealing kit.
- N9. Copper lug for use with COPPER CONDUCTOR ONLY. DO NOT substitute threaded 03602X lug.
- N10. Available without the bolt & washers by adding "N" to the part number.
- N11. Direct Test Connectors, along with a 200TC-X series meter adapter, a properly rated voltage meter and Hot-line Stick; provides a means for direct conductor voltage testing. See page 11 for meter adapters.

Refer to the **W** and **X** tables on pages 38 and 39 for sizing to cable insulation diameter and conductor size.  
For cable shield adapters and jacket seals, see page 28.

Elastimold multi-point junctions are available in 2, 3, 4, 5 or 6 point configurations with 15, 25 or 35kV ratings. Units feature modular design flexibility, allowing selection of any combination of 200 Amp deepwell or 600 Amp bushing interfaces located on standard 4" or optional 6 1/2" centers. The 6-1/2" center spacing is especially well suited for Distributed Switchgear applications including fused elbow, MVI fault interrupter, MVS switch, etc.

Designs incorporate lightweight, damage resistant, EPDM molded rubber construction and corrosion resistant 304 stainless steel mounting brackets. Junctions are maintenance-free, fully shielded, deadfront and submersible. Units are ideally suited for subsurface, padmount, indoor and outdoor vault applications.

Elastimold multi-point junctions provide a convenient method for connecting, looping and tapping of 200 and 600 Amp elbows and other accessories at a common location where utilization of space, cable training, flexibility and operability are important.

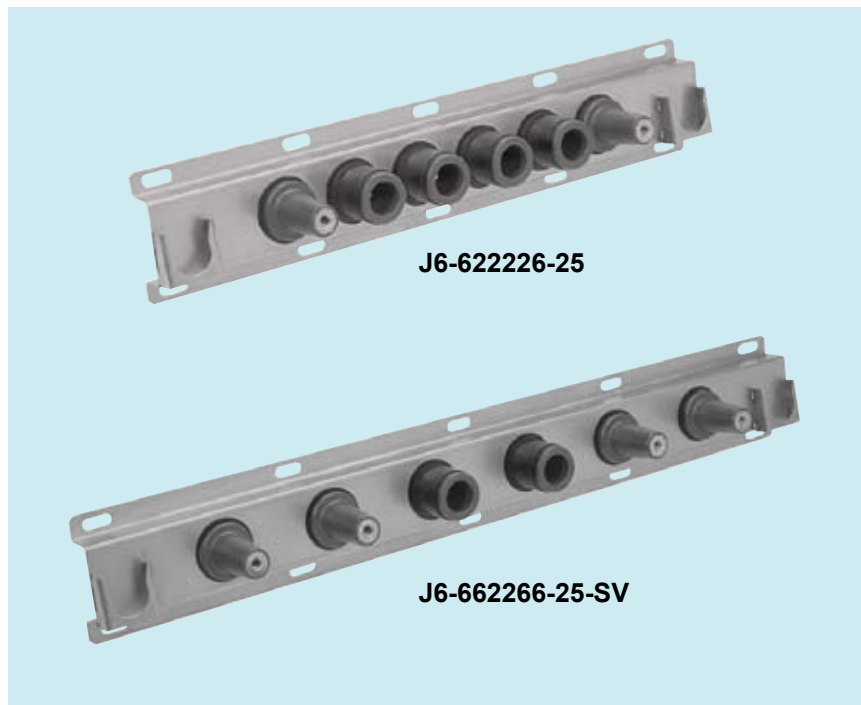

### RATINGS OVERVIEW

See page 2 for complete information

#### CURRENT RATINGS

600 Amp Continuous  
25kA sym., 10 cycles  
*or with 200 Amp Bushing Well versions*

200 Amp Continuous  
10kA sym., 10 cycles

#### VOLTAGE RATINGS

##### 15kV Class

8.3kV Phase-to-Ground  
95kV BIL  
34kV AC Withstand  
53kV DC Withstand  
11kV Corona Extinction

##### 25kV Class

16.2kV Phase-to-Ground  
140kV BIL  
45kV AC Withstand  
84kV DC Withstand  
21.5kV Corona Extinction



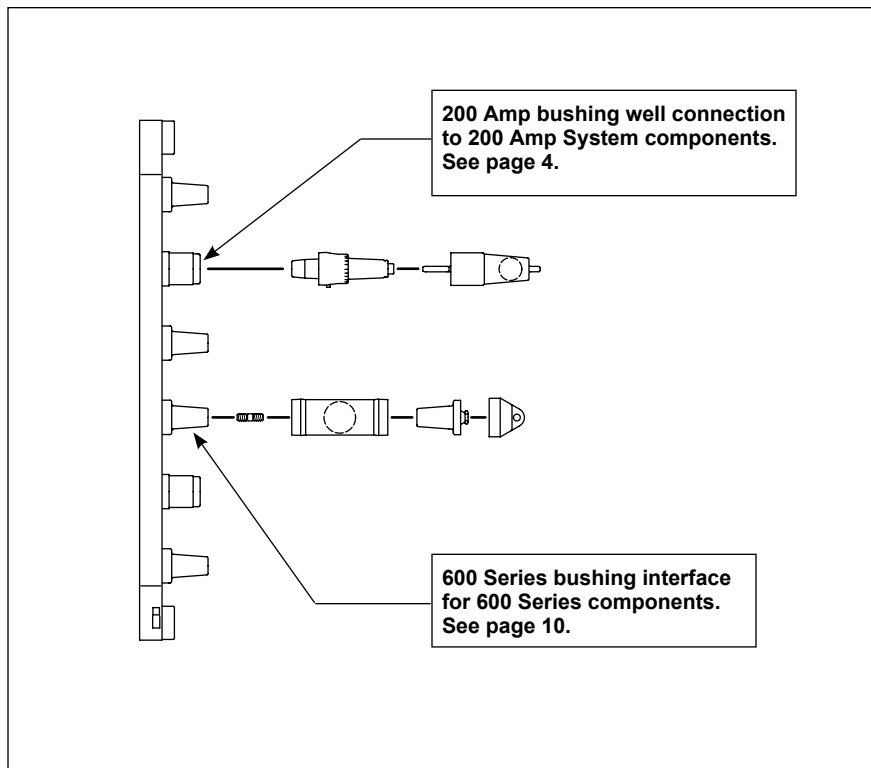

##### 35kV Class

21.1kV Phase-to-Ground  
150kV BIL  
50kV AC Withstand  
103kV DC Withstand  
26kV Corona Extinction

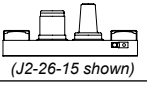

The Elastimold multi-point junctions feature modular design flexibility that permits the specifier to determine the positions of the bushing interfaces and bushing well positions.

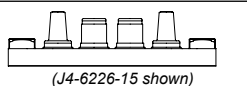
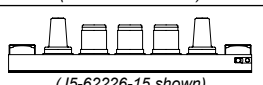
### Base Catalog Numbers

Illustration (not to scale)	Description	Voltage Class	ELASTIMOLD Part Number		Notes
			4" Spacing	6-1/2" Spacing	
 (J2-26-15 shown)	2-point Junction	15kV 25kV 35kV	J2 - ___ - 15 J2 - ___ - 25 J2 - ___ - 35	J2 - ___ - 15-SV J2 - ___ - 25-SV J2 - ___ - 35-SV	N1, 2
 (J3-626-35 shown)	3-point Junction	15kV 25kV 35kV	J3 - _____ - 15 J3 - _____ - 25 J3 - _____ - 35	J3 - _____ - 15-SV J3 - _____ - 25-SV J3 - _____ - 35-SV	N1, 2
 (J4-6226-15 shown)	4-point Junction	15kV 25kV 35kV	J4 - _____ - 15 J4 - _____ - 25 J4 - _____ - 35	J4 - _____ - 15-SV J4 - _____ - 25-SV J4 - _____ - 35-SV	N1, 2
 (J5-62226-15 shown)	5-point Junction	15kV 25kV 35kV	J5 - _____ - 15 J5 - _____ - 25 J5 - _____ - 35	J5 - _____ - 15-SV J5 - _____ - 25-SV J5 - _____ - 35-SV	N1, 2
 (J6-622226-15 shown)	6-point Junction	15kV 25kV 35kV	J6 - _____ - 15 J6 - _____ - 25 J6 - _____ - 35	J6 - _____ - 15-SV J6 - _____ - 25-SV J6 - _____ - 35-SV	N1, 2

Molded Multi-Point Junctions

### ORDERING INFORMATION

To specify and order Elastimold Multi-Point Junctions:

- Use Table 1 to construct a catalog number describing the required junction.

**Table 1. Catalog Number Construction**

**J**

Multi-Point Junction

□

-

□ □ □ □ □ □

-

□ □

-

□ □

-

□ □ □

Number of Points		Interface Identification * and Positioning		Voltage Class		Interface Spacing		Options	
2	2 Points	2	200 Amp Deepwell Interface	15	15kV	Blank	Standard spacing – 4" centers	Blank	No tilt mounting bracket
3	3 Points	6	600 Amp Bushing Interface	25	25kV	SV	Optional 6-1/2" centers	TMA	Tilt Mounting Adapter. Bolts to the bottom of the standard mounting bracket to provide 15, 30, 45 or 60 degree adjustable angle mounting. (Two Tilt Mounting Adapters are required for each installation.)
4	4 Points	B	Blank Position	35	35kV				
5	5 Points	* When there is a 200 Amp Interface on one side of the junction and a 600 Series Interface on the other side, always start with the 200 Amp side.							
6	6 Points								

#### Ordering Example A

To order a 4-point, 15kV junction with 4" spacings and 600 series interfaces on the outside ways and 200 Amp wells on the inside ways specify: Catalog Number J4-6226-15.

#### Ordering Example B

To order a 6-point, 25kV junction with 6-1/2" spacings and 600 series interfaces on the ways 1, 3, 4, 6 and 200 Amp wells on the ways 2 and 5 specify: Catalog Number J6-626626-25-SV.

N1. The 6-1/2" wide spacing is necessary if the junction is to be used to connect with a single phase MVS Molded Vacuum Switch or MVI Molded Vacuum Interrupter.

N2. Also available with a shorter bracket without parking stands, consult factory.

PCJ™ Power Cable Joints utilize permanently crimped connectors. PCJ Housings are fully insulated, shielded and sealed for direct buried, vault, submersible and other severe service applications. Units have been designed and tested per IEEE Standard 404 to assure system matched performance and ratings equal to the cable to which the splice will be installed.

PCJ Power Cable Joints are available in 2 styles:

Style 1 uses a single piece housing that is sized to accommodate a specific range of cable. Style 1 units are ideally suited for straight splicing of the same or similar cable.

Style 2 designs incorporate a universal housing with separate cable adapters to allow transition splices of different types and sizes of cable.



### ELECTRICAL RATINGS SUMMARY

The follow ratings summary is based on **IEEE Std. 404** and applies to all Elastimold PCJ Power Cable Joints.

#### VOLTAGE

- A. 15kV Class (8.7kV Phase-to-Ground)
- B. 25kV Class (14.4kV Phase-to-Ground)
- C. 35kV Class (20.2kV Phase-to-Ground)

- **Impulse Withstand:** A=110kV, B=150kV, C=200kV BIL, 1.2 x 50 microsecond wave.
- **Corona Extinction Voltage:** A=13kV, B=22kV, C=30kV minimum, 3pC sensitivity.
- **DC Withstand:** During installation: A=56kV, B=80kV, C=100kV
- **DC Withstand:**  
After installation and in service for the first 5 years:  
A=18kV, B=25kV, C=31kV for XLPE Insulated Cables  
and A=45kV, B=64kV, C=80kV for EPR Insulated Cables.  
(Reference AEIC CS6 and CS8, Section L.2.)

#### CURRENT

- Continuous rating equal to the rating of the cable.
- Short-Time rating equal to the rating of the cable up to 35kA.

#### SHIELD DESIGN

- Meets IEEE standard 592 for Exposed Semiconducting Shields on Premolded High Voltage Cable Joints and Separable Insulated Connectors.

**Production tests include 100% tests of the premolded joints to assure:**

- **Corona Extinction Voltage:** A=13kV, B=22kV, C=30kV minimum, 3pC sensitivity.
- **AC Withstand:** A=35kV, B=52kV, C=69kV, 60 Hz, 1 minute.

**Design tests on production joints demonstrate compliance with IEEE 404 including:**

- **Corona Extinction Voltage:** A=13.0kV, B=22.0kV, C=30.0kV minimum, 3pC sensitivity.
- **AC Withstand:** A=35kV, B=52kV, C=69kV, 60 Hz 1 minute.
- **DC Withstand:** A=70kV, B=100kV, C=125kV negative polarity, 15 minutes.
- **Impulse Withstand (BIL):** A=110kV, B=150kV, C=200kV, 10 positive and 10 negative, 1.2 x 50 microsecond wave, at conductor temperatures of 20° and 130°C, nominal.
- **Short-Time Current:** magnitude equal to cable up to 35kA.
- **Cyclic Aging:** 30 days at: A=26.1kV, B=43.2kV, C=60.6kV AC continuous, load current for 8 hours per day, providing 130° conductor temperature. Joints then subjected to: A=31kV, B=50kV, C=71kV for 5 hours followed by: A=39kV, B=65kV, C=91kV for 5 min.
- **Load Cycle:** Connectors meet requirements of ANSI C119.4, Class A and Class 3 ratings.

### PCJ Style 1 with single-piece housing

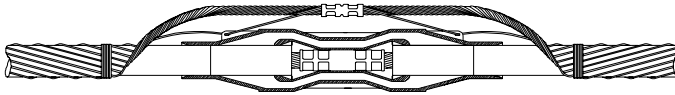

### PCJ Style 2 with universal housing and separate cable adapters that can be varied with the cable application.

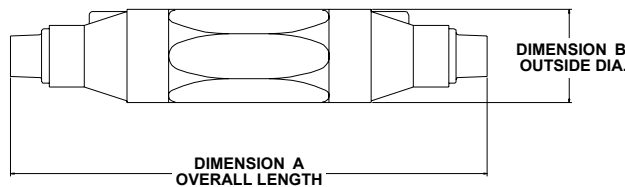
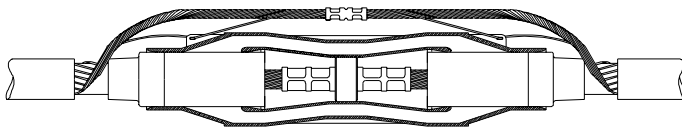

### ORDERING INFORMATION

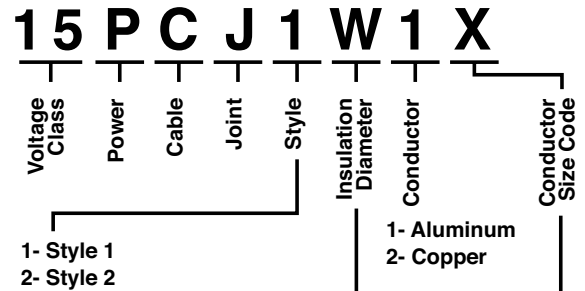

### W SIZING INFORMATION AND SELECTION

Use Table W8 for 15PCJ  
Use Table W9 for 25PCJ  
Use Table W10 for 35PCJ

### X SIZING INFORMATION AND SELECTION

Use Table X7 for 15PCJ, 25PCJ and 35PCJ

### DIMENSIONAL DATA

STYLE 1 PART NUMBER	A	B
	inches	inches
15PCJ1FX	10 1/4"	1 3/4"
15PCJ1GX	10 1/4"	1 3/4"
25PCJ1GX	14 3/8"	2 7/16"
15/25/35PCJ1HX	14 3/8"	2 7/16"
15/25/35PCJ1JX	14 3/8"	2 7/16"
15/25/35PCJ1KX	14 3/8"	2 25/32"
15/25/35PCJ1LX	14 3/8"	2 25/32"
15/25PCJ1LMX	14 3/8"	2 25/32"
15/25/35PCJ1MX	14 3/8"	2 25/32"
15/25/35PCJ1NX	15 3/4"	3 3/16"
15/25/35PCJ1PX	15 3/4"	3 3/16"
15/25/35PCJ1QX	15 3/4"	3 3/16"

STYLE 2 PART NUMBER	A	B
	inches	inches
15PCJ2FX	16 3/8"	2 25/32"
15/25PCJ2GX	16 3/8"	2 25/32"
15/25/35PCJ2HX	16 3/8"	2 25/32"
15/25/35PCJ2JX	16 3/8"	2 25/32"
15/25/35PCJ2KX	21"	3 3/4"
15/25/35PCJ2LX	21"	3 3/4"
15/25/35PCJ2MX	21"	3 3/4"
15/25/35PCJ2NX	21"	3 3/4"
15/25/35PCJ2PX	21"	3 3/4"
15/25/35PCJ2QX	21"	3 3/4"

Description	Voltage Class	ELASTIMOLD Part Number	Notes
Power Cable Joint  Style 1	15kV	15PCJ1W1X	N1
	15kV	15PCJ1W2X	N2
	25kV	25PCJ1W1X	N1
	25kV	25PCJ1W2X	N2
	35kV	35PCJ1W1X	N1
	35kV	35PCJ1W2X	N2
Power Cable Joint  Style 2	15kV	15PCJ2W1X	N1
	15kV	15PCJ2W2X	N2
	25kV	25PCJ2W1X	N1
	25kV	25PCJ2W2X	N2
	35kV	35PCJ2W1X	N1
	35kV	35PCJ2W2X	N2

- N1. Kit includes aluminum compression connector suitable for splicing aluminum conductor to aluminum conductor or aluminum conductor to copper conductor. An all-copper connector is required for copper to copper connections.
- N2. Kit includes copper compression connector suitable for splicing copper conductors to copper conductor only. DO NOT use copper connectors on aluminum conductors.

Refer to the **W** and **X** tables on pages 38 and 39 for sizing to cable insulation diameter and conductor size.

For cable shield adapters and jacket seals, see page 28.

Elastimold cable terminations are available in single piece or modular designs. Terminators allow connection and transition from shielded, underground cable to bare overhead conductors and live-front equipment. Units are designed and rated per IEEE Standard 48 for riser pole, padmount, indoor and outdoor applications. PCT1, PCT2, 16THG and 35MTG terminators provide sufficient creep, strike and weather sealing for class 1 outdoor service. PCT1 and PCT2 also include an integral cable jacket seal.

The 35MTGI terminators and 35MSC stress cones are rated for class 2 and class 3 indoor service respectively. Optional mounting brackets, aerial lugs and equipment connectors are available as required.

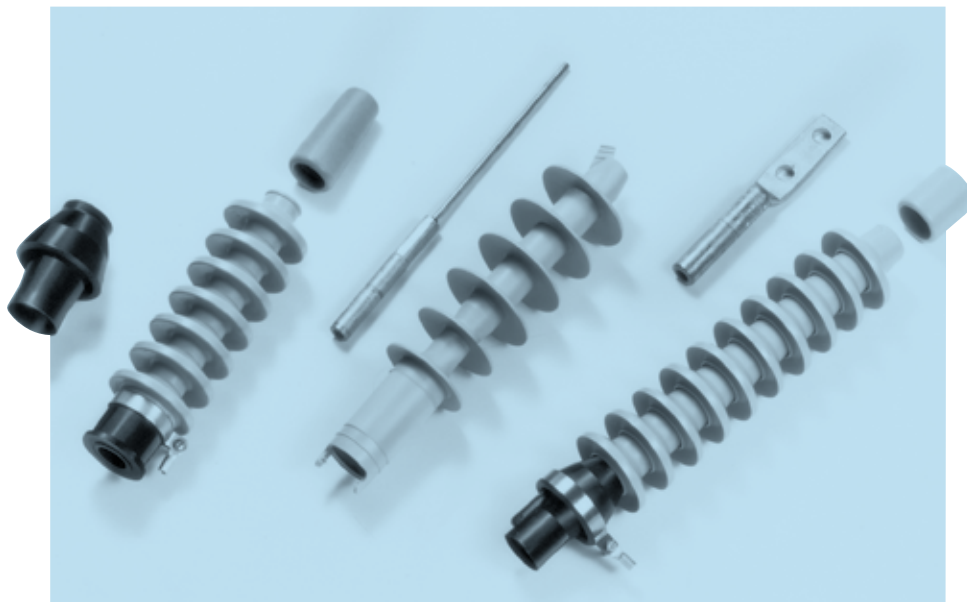

### ELECTRICAL RATINGS SUMMARY

The following ratings summary is based on IEEE Std. 48 and applies to all the terminations on page 24 thru 27. Elastimold terminations are designed for use on three-phase systems, either 3-wire or 4-wire and the single-phase laterals of these systems.

#### VOLTAGE RATINGS

##### 15kV Class

9.5kV Phase-to-Ground  
110kV BIL 1.2 x 50 microsecond wave  
AC Withstand:  
50kV 1 min. – dry  
35kV 6 hr. – dry  
45kV 10 sec. – wet  
13kV Corona Extinction

##### 25kV Class

16kV Phase-to-Ground  
150kV BIL 1.2 x 50 microsecond wave  
AC Withstand:  
65kV 1 min. – dry  
55kV 6 hr. – dry  
60kV 10 sec. – wet  
21.5kV Corona Extinction

##### 35kV Class

22kV Phase-to-Ground  
200kV BIL 1.2 x 50 microsecond wave  
AC Withstand:  
90kV 1 min. – dry  
75kV 6 hr. – dry  
80kV 10 sec. – wet  
30kV Corona Extinction

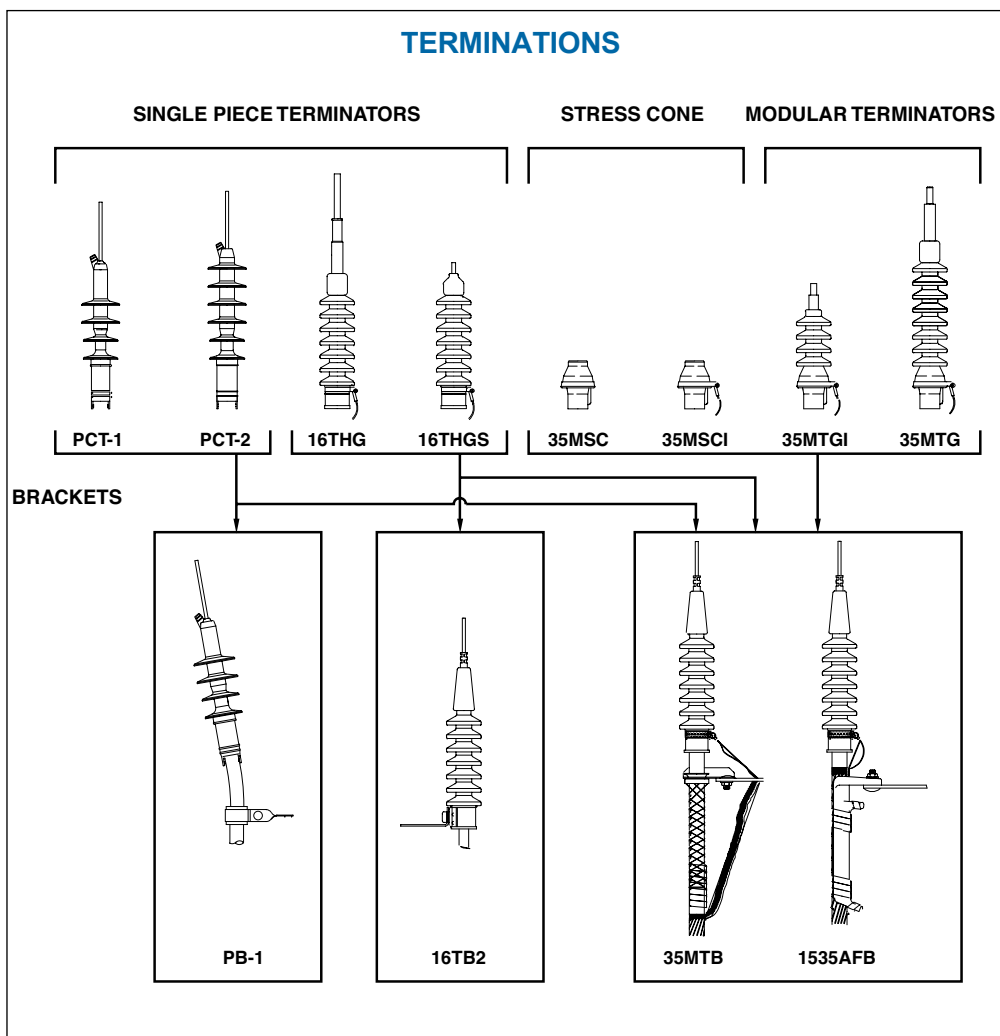

### TERMINATIONS

Illustration (not to scale)	Description	Voltage Class	ELASTIMOLD Part Number	Notes
	Single-Piece Terminator (Class 1)	15kV 25kV	<b>PCT1-1X-4</b> Use Table X9 <b>PCT2-1X-4</b> Use Table X9	N12, 14, 15, 22 N12, 14, 15, 23
	Housing only	15kV 25kV	<b>PCT1-4</b> <b>PCT2-4</b>	N13, 22 N13, 23
	Single-Piece Terminator (Class 1)	15/25kV	<b>16THG-WX-4</b> Use Tables W12 and X8	N2, 14 15
	Housing only	15/25kV	<b>16THGH-W</b> Use Table W12	
	Single-Piece Terminator for solid conductor only (Class 1)	15/25kV	<b>16THGS-WX</b> Use Tables W12 and X4	N3
	Stress Cone (Class 3)	ALL	<b>35MSC-W</b> Use Table W11	N17
	Stress Cone w/Grd. Strap	ALL	<b>35MSCI-W</b> Use Table W11	N17
	Modules only	ALL	<b>35MG-W</b> Use Table W13	N11, 16
	Modular Terminator (Class 1)	15kV	<b>35MTG-WX-4-CA</b> Use Tables W13 and X3	N2, 11
		25kV	<b>35MTG-WX-8-CA</b> Use Tables W13 and X3	N2, 5, 11
		35kV	<b>35MTG-WX-10-CA</b> Use Tables W13 and X3	N2, 6, 11
	Modular Terminator (Class 2) w/o Rain Cap	15kV	<b>35MTGI-W-4</b> Use Table W13	N11
		25kV	<b>35MTGI-W-6</b> Use Table W13	N11
		35kV	<b>35MTGI-W-8</b> Use Table W13	N7, 11
	Rod Contact for PCT	15/25kV	<b>00700X</b> Use Table X9	N1, 14, 15
	Rod Contact for 16THG	15/25kV	<b>16TCA-X</b> Use Table X8	N2, 8
	Solid Conductor Package for 16THGS	15/25kV	<b>16CAS-X</b> Use Table X4	N3, 9
	3/4"-16 Threaded Rod for MTG	ALL	<b>35MTGA-WX-1</b> Use Tables W13 and X3	N2, 10, 11 18, 25
	1"-14 Threaded Rod for MTG	ALL	<b>35MTGA-WX-2</b> Use Tables W13 and X3A	N2, 10, 11 19, 25
	Two-Hole Spade for MTG	ALL	<b>35MTGA-WX-3</b> Use Tables W13 and X3	N4, 10, 11 20, 25
	Two-Hole Spade for PCT	ALL	<b>01000X</b> Use Table X9	N1
	One-Hole Spade for PCT	ALL	<b>01100X</b> Use Table X9	N1
	Universal Rod for MTG	ALL	<b>35MTGA-WX-4</b> Use Tables W13 and X3	N2, 10, 11 21, 25
	Aerial Lugs for MTG Threaded Rod (Two-hole spade or bare wire)	ALL	<b>35AL-A</b>	N10, 24

- N1. Use with PCT1 or PCT2 Terminators.
- N2. Includes contact rod, ground strap and rain cap.
- N3. Includes crimp ring, ground strap and rain cap.
- N4. Includes spade contact, ground strap and rain cap.
- N5. For KA thru PB sizes use 35MTG-WX-6-CA.
- N6. For KA thru PB sizes use 35MTG-WX-8-CA.
- N7. For KA thru PB sizes use 35MTGI-W-6.
- N8. Use with 16THG Terminators.
- N9. Use with 16THGS Terminators.
- N10. Use with 35MTG Terminators.
- N11. Refer to page 26 for detailed ordering instructions.
- N12. Includes rod contact as standard. Specify suffix "-3" in place of "-4" for two-hole spade lug. Specify suffix "-5" in place of "-4" for one-hole spade lug.
- N13. Specify suffix "-3" or "-5" in place of "-4" for two-hole spade lug housing or one-hole spade style housing.
- N14. Use 1X for an aluminum rod contact for aluminum conductors only.
- N15. Substitute 0X for 1X for a universal aluminum rod contact for aluminum or copper conductors.
- N16. Available in sizes from GA thru PB & are supplied qty. 2 per package.
- N17. Available in sizes EB thru PB.
- N18. For conductors from 1/0 thru 350 kcmil.
- N19. For conductors from 400 kcmil thru 1000 kcmil.
- N20. For conductors from #2 to 1000 kcmil.
- N21. For conductors from #6 thru 4/0.
- N22. Use for insulation dia. range from .640" thru 1.070".
- N23. Use for insulation dia. range from .830" thru 1.180".
- N24. Select symbol for "A" from aerial lug ordering information on page 26.
- N25. W13 Table provides sizing for rain cap.  
X10 Table provides sizing for connectors.

Refer to the **W** and **X** tables on pages 38 and 39 for sizing to cable insulation diameter and conductor size.

For cable shield adapters and jacket seals, see page 28.

### ORDERING INSTRUCTIONS FOR MODULAR TERMINATORS

**35MTG - W X - N - C A**

I = Indoor  
Blank = Outdoor

Use Table W13, below

Use Table X3 or Table X3A

NOTE: Applicable table and available sizes depend upon connector style. Reference Connector Style Selection Chart and notes A through D.

#### Recommended Number of Modules

	GA-JB	KA-PB
15kV	4	4
25kV	8	6
35kV	10	8

#### Connector Style Selection Chart

Description	Available for Conductor Sizes	Symbol	Notes
3/4"-16 Threaded Rod	1/0 thru 350 kcmil	-1	A
1"-14 Threaded Rod	400 thru 1000 kcmil	-2	B
2-Hole Spade	#2 thru 1000 kcmil	-3	C
Universal Rod	#6 thru 4/0	-4	D

#### Aerial Lugs for Threaded Rod Connectors Only

Type	Connector	Symbol
Bare Wire	3/4"-16 Rod	-11
2-Hole Spade	3/4"-16 Rod	-12
Bare Wire	1"-14 Rod	-21
2-Hole Spade	1"-14 Rod	-22

#### NOTES:









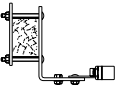
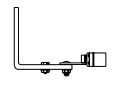

- A. Available for 1/0 through 350 conductor sizes only. Use Table X3 for size selection.
- B. Available for 400 through 1000 conductor sizes only. Use Table X3A for size selection.
- C. Available for #2 through 1000 conductor sizes only. Use Table X3 for size selection.
- D. Available for #6 through 4/0 conductor sizes only. Use Table X3 for size selection.

Table W13 USE FOR FOLLOWING PRODUCTS <b>35MTG</b> <b>35MTGI</b>	Cable Insulation Diameter in Inches		Symbol for W
	MIN.	MAX.	
	.775	.885	GA
	.825	.935	GAB
	.875	.985	GB
	.930	1.040	GH
	.980	1.115	HA
	1.040	1.175	HAB
	1.095	1.240	HB
	1.160	1.305	HJ
	1.220	1.375	JA
	1.285	1.395	JAB
	1.355	1.520	JB
	1.485	1.595	KA
	1.530	1.640	KAB
	1.575	1.685	KB
	1.665	1.785	PA
	1.755	1.875	PB

Table X3 USE FOR FOLLOWING PRODUCT <b>35MTG</b>  FOR USE WITH STYLE -1, -3, & -4 CONNECTORS ONLY.  SEE NOTES A, C, & D FOR APPLICATION INFORMATION	Conductor SIZE AWG or kcmil	Symbol for X	
		Strand./ Compr.	Compt./ Solid.
	#6	5	-
	#5	4	5
	#4	3	4
	#3	2	3
	#2	1	2
	#1	0	1
	1/0	10	0
	2/0	20	10
	3/0	30	20
	4/0	40	30
	250	250	40
	300	300	250
	350	350	300
	400	400	350
	450	450	-
	500	500	400
	550	550	450
	600	600	500
	650	650	550
	700	750	600
	750	750	650
	800	800	750
	900	900	800
	1000	1000	900

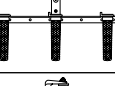
Table X3A USE FOR FOLLOWING PRODUCT <b>35MTG</b>  FOR USE WITH STYLE -2 CONNECTORS ONLY.  SEE NOTE B FOR APPLICATION INFORMATION	Conductor SIZE AWG or kcmil	Symbol for X	
		Strand./ Compr.	Compt./ Solid.
	400	400	-
	450	450	400
	500	500	450
	550	550	500
	600	600	500
	650-700	650	550
	750	750	600
	800	750	650
	1000	1000	-

### TERMINATIONS

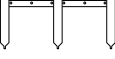
Illustration (not to scale)	Description	Voltage Class	ELASTIMOLD Part Number	Notes
	PCT Positioning Bracket	ALL	<b>PB-1</b>	N1,12
	16THG Bracket	ALL	<b>16TB-2</b>	N6
	Bracket for crossarm mounting 16THG	ALL	<b>16TB-3</b>	N6
	Bracket for riser pole mounting 16THG	ALL	<b>16TB-4</b>	N6
	Bracket for tri-mounting 16THG	ALL	<b>16TB-5</b>	N6
	KELLUMS GRIP Bracket	ALL ALL ALL ALL	<b>35MTB1-A</b> <b>35MTB1-B</b> <b>35MTB1-C</b> <b>35MTB1-D</b>	N1,2,6,7 N1,3,6,7 N1,4,6,7 N1,5,6,7
	KELLUMS Bracket for crossarm mounting	ALL ALL ALL ALL	<b>35MTB3-A</b> <b>35MTB3-B</b> <b>35MTB3-C</b> <b>35MTB3-D</b>	N1,2,6,7 N1,3,6,7 N1,4,6,7 N1,5,6,7
	Bracket (for riser pole mounting)	ALL ALL ALL ALL	<b>35MTB4-A</b> <b>35MTB4-B</b> <b>35MTB4-C</b> <b>35MTB4-D</b>	N1,2,6,7 N1,3,6,7 N1,4,6,7 N1,5,6,7
	KELLUMS Bracket for tri-mounting	ALL ALL ALL ALL	<b>35MTB5-A</b> <b>35MTB5-B</b> <b>35MTB5-C</b> <b>35MTB5-D</b>	N1,2,6,7 N1,3,6,7 N1,4,6,7 N1,5,6,7
	ALUMA FORM Bracket	ALL	<b>1535AFB-1</b>	N1,6,7,13
	ALUMA FORM Bracket for Crossarm mounting	ALL	<b>1535AFB-3</b>	N1,6,7,13
	ALUMA FORM Bracket for riser-pole mounting	ALL	<b>1535AFB-4</b>	N1,6,7,13
	ALUMA FORM Bracket for tri-mounting	ALL	<b>1535AFB-5</b>	N1,6,7,13

- N1. Use with PCT-1 or PCT-2 Terminators.
- N2. Fits overall cable O.D. from 1.195" to 1.625".
- N3. Fits overall cable O.D. from .925" to 1.335".
- N4. Fits overall cable O.D. from .890" to 1.185".
- N5. Fits overall cable O.D. from 1.500" to 2.000".
- N6. Use with 16THG & 16THGS Terminators.
- N7. Use with MTG, MTG1 & MSC Terminators.
- N8. For conductors from 1/0 thru 350 kcmil.
- N9. For conductors from 400 kcmil thru 1000 kcmil.
- N10. For conductors from #2 to 1000 kcmil.
- N11. For conductors from #6 thru 4/0.
- N12. Fits overall cable O.D. from .750" to 1.625"
- N13. Fits overall cable O.D. from .750" to 2.000"

Refer to the **W** and **X** tables on pages 38 and 39 for sizing to cable insulation diameter and conductor size.

For cable shield adapters and jacket seals, see page 28.

# CABLE ACCESSORIES

## Shield Adapters, Sealing & Grounding

Elastimold elbows, cable joints and terminators have been designed for use on XLP, EPR or similar solid dielectric insulated power cables. These cables are available with a variety of optional shielding and jacket constructions. In order to properly mate and install the cable to an Elastimold product, the use of a shield adaptor, grounding kit or jacket seal may be required. The diagram below provides information concerning the application and selection of various shield adaptors, grounding kits and jacket seals for the most popular cable types. Consult the factory for recommendations concerning other cable constructions.

CABLE ENTRANCE DETAIL

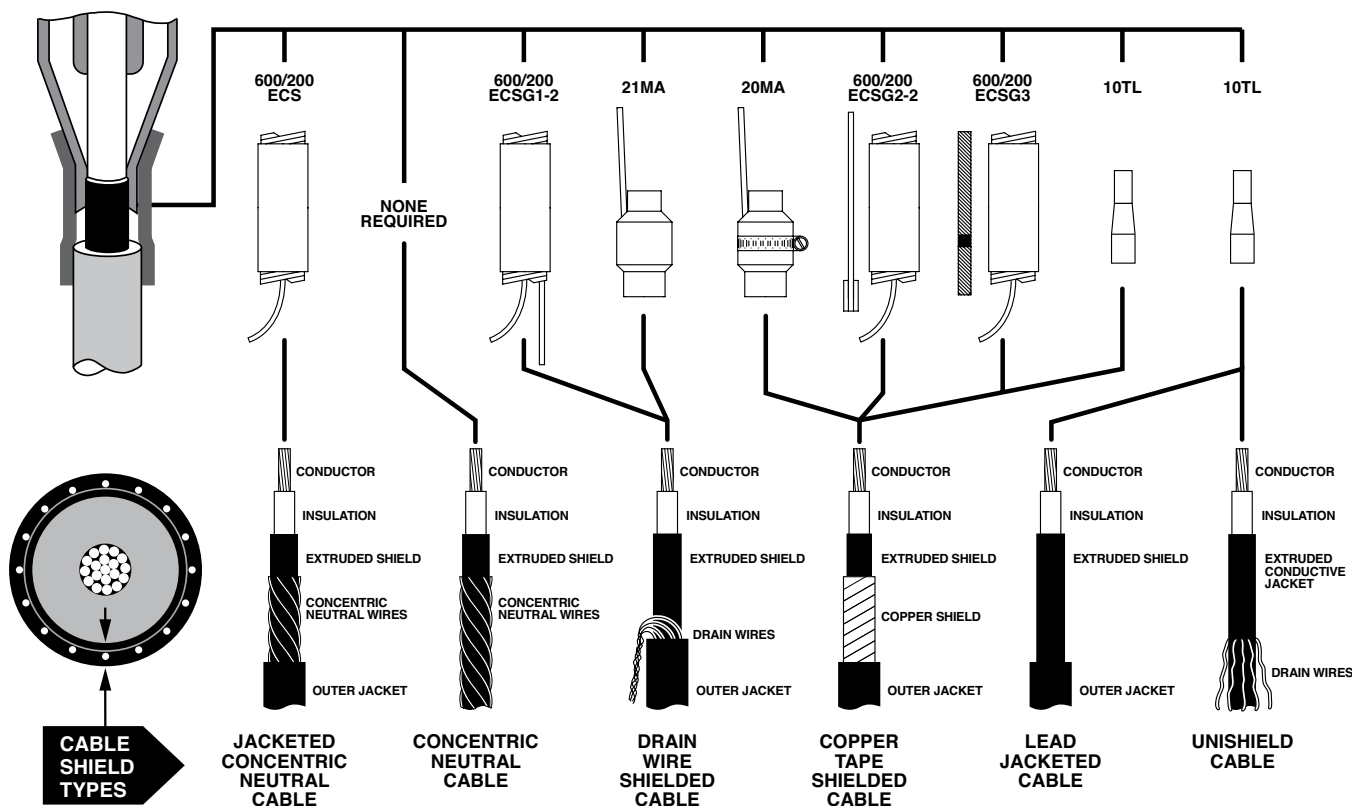
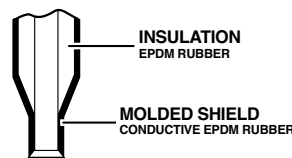

Shield Adapters, Grounding Kits and Jacket Seals

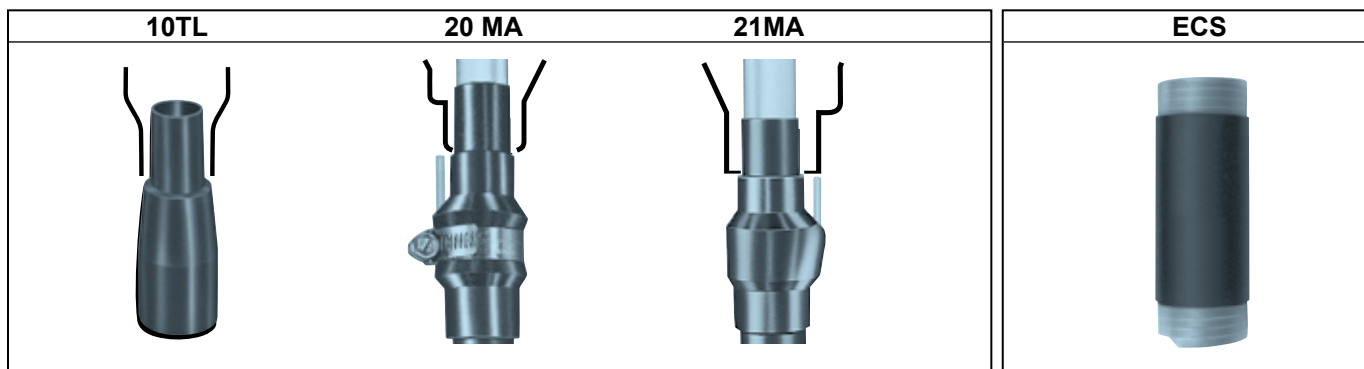

CABLE SHIELD ADAPTERS			
Cable Insulation Dia.	10TL	20MA	21MA
	inches	inches	inches
min.	.495	.530	.530
max.	1.875	1.780	1.780

JACKET SEALS		
Jacket O.D.	200ECS	600ECS
	inches	inches
min.	.80	1.28
max.	1.50	2.30

Illustration (not to scale)	Description	ELASTIMOLD Part Number	Suffix	Notes
	Cold Shrinkable Jacket Seal	<b>200ECS</b>	<b>-S</b>	N1,3
	Cold Shrinkable Jacket Seal	<b>600ECS</b>	<b>-S</b>	N1,4
	Metallic Tape Shield Adapter	<b>20MA-W</b> Use Table W14 for sizing	<b>-OMA</b>	N1,2,5,6
	Wire Shield Adapter	<b>21MA-W</b> Use Table W14 for sizing	<b>-1MA</b>	N1,2,5,6
	Shield Adapter	<b>10TL-W</b> Use Table W15 for sizing	<b>-TL</b>	N1,2
	Cold Shrinkable Seal w/ Copper Rod & Crimp Connector	<b>200ECSG1-2</b>	<b>-SG1</b>	N1,3,5,6
	Cold Shrinkable Seal w/ Copper Rod & Crimp Connector	<b>600ECSG1-2</b>	<b>-SG1</b>	N1,4,5,6
	Cold Shrinkable Seal w/ Copper Rod & Constant Force Spring	<b>200ECSG2-2</b>	<b>-SG2</b>	N1,3,5,6
	Cold Shrinkable Seal w/ Copper Rod & Constant Force Spring	<b>600ECSG2-2</b>	<b>-SG2</b>	N1,4,5,6
	Cold Shrinkable Seal w/ Copper Braid & Constant Force Spring	<b>200ECSG3</b>	<b>-SG3</b>	N1,3,5,7
	Cold Shrinkable Seal w/ Copper Braid & Constant Force Spring	<b>600ECSG3</b>	<b>-SG3</b>	N1,4,5,7

N1. To order the kits as separate items, use the part numbers shown in the table. Example: To order a cold shrinkable tube as a separate item, use the part number 200ECS.

To order the kits as components of other items, add the suffix to the end of the part number. Example: To order a cold shrinkable jacket seal as a component of an elbow kit, use the part number 166LR-A5200-S.

N2. Only use this suffix with part numbers that designate a "W" housing size. Sizing the main component will also size the suffix adapter.

N3. Size range .80" to 1.50" jacket diameters. Maximum installed diameter is approx. 2".

N4. Size range 1.28" to 2.30" jacket diameters. Maximum installed diameter is approx. 2.75".

N5. Voltage rating equal to Elastimold product being used.

N6. Copper rod size is no. 6 for sizes FA thru HA and no. 2 for sizes HAB thru JB.







N7. Braid is equivalent to no. 6 copper rod for sizes FA thru HA and no. 2 copper rod for sizes HAB thru JB.

	Insulation Inches		Symbol for W
	MIN.	MAX.	
	.530	.680	E
	.640	.820	F
	.760	.950	G
	.850	1.050	H
	.980	1.180	J
	1.090	1.310	K
	1.180	1.465	L
	1.370	1.630	M
	1.515	1.780	N

	Insulation Inches		Symbol for W
	MIN.	MAX.	
	.495	.585	EB
	.525	.635	EF
	.575	.585	FA
	.625	.735	FAB
	.675	.785	FB
	.725	.835	FG
	.775	.885	GA
	.825	.935	GAB
	.875	.985	GB
	.930	1.040	GH
	.980	1.115	HA
	1.040	1.175	HAB
	1.095	1.240	HB
	1.160	1.305	HJ
	1.220	1.375	JA
	1.285	1.395	JAB
	1.355	1.520	JB
	1.485	1.595	KA
	1.530	1.640	KAB
	1.575	1.685	KB
	1.755	1.875	PB

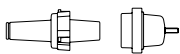
Elastimold manufactures a complete line of 200 Amp deepwell and 600 Series apparatus bushings for use on transformers, switchgear and other equipment applications. The bushings incorporate IEEE 386 standard interfaces (shown on page 3) and are constructed of molded epoxy with stainless steel flanges for mounting by welding or gasketed clamp. K1601PCC series bushings are provided with a molded epoxy

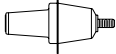
flange for gasketed clamp mounting only. Bushings are available for use on AIR, OIL or SF6 insulated equipment. Units are rated for submersible, padmount, indoor, outdoor and other applications. Options include hold-down bail tabs and replaceable studs for 200 Amp deepwell bushings.

Illustration (not to scale)	Description	Voltage Class	ELASTIMOLD Part Number	Bushing Shank Length	Notes
	Short Shank Well with bail tabs and non-replaceable well stud	15/25kV 35kV	<b>K1601PC-S1</b> <b>L1601PC-S1</b>	2 <sup>3</sup> / <sub>4</sub> "	N3,7,14
	Short Shank Well with bail tabs and with replaceable well stud	15/25kV 35kV	<b>K1601PC-S1-R</b> <b>L1601PC-S1-R</b>	2 <sup>3</sup> / <sub>4</sub> "	N1,3,7,14
	Short Shank Well without bail tabs and non-replaceable well stud	15/25kV 35kV	<b>K1601PC-S2</b> <b>L1601PC-S2</b>	2 <sup>3</sup> / <sub>4</sub> "	N3,7,14
	Short Shank Well without bail tabs and with replaceable well stud	15/25kV 35kV	<b>K1601PC-S2-R</b> <b>L1601PC-S2-R</b>	2 <sup>3</sup> / <sub>4</sub> "	N1,3,7,14
	Long Shank Well with bail tabs and non-replaceable well stud	15/25kV 35kV	<b>K1601PC-T1</b> <b>L1601PC-T1</b>	9 <sup>1</sup> / <sub>4</sub> "	N3,7,14
	Long Shank Well with bail tabs and with replaceable well stud	15/25kV 35kV	<b>K1601PC-T1-R</b> <b>L1601PC-T1-R</b>	9 <sup>1</sup> / <sub>4</sub> "	N1,3,7,14
	Long Shank Well without bail tabs and non-replaceable well stud	15/25kV 35kV	<b>K1601PC-T2</b> <b>L1601PC-T2</b>	9 <sup>1</sup> / <sub>4</sub> "	N3,7,14
	Long Shank Well without bail tabs and with replaceable well stud	15/25kV 35kV	<b>K1601PC-T2-R</b> <b>L1601PC-T2-R</b>	9 <sup>1</sup> / <sub>4</sub> "	N1,3,7,14
	Epoxy Flange Well with replaceable well stud	15/25kV	<b>K1601PCC-R</b>		N1,3,7,14
	Well w/Insert (K1601PCC-R & 1601A4) Well w/Insert (K1601PCC-R & 2701A4)	15kV 25kV	<b>1601CABA4R</b> <b>2701CABA4R</b>	2 <sup>3</sup> / <sub>4</sub> "	N1,3,8,14 N1,3,9,14
	200 A Deadbreak Bushing	15/25kV	<b>K180S4</b>	2 <sup>9</sup> / <sub>16</sub> "	N3,10,13
	200 A Deadbreak Bushing	15/25kV	<b>K180T4</b>	7 <sup>11</sup> / <sub>32</sub> "	
	200 A Deadbreak Bushing	15/25kV	<b>K180C4</b>	9 <sup>1</sup> / <sub>4</sub> "	
	600 A Short Shank Bushing w.o./stud	15/25kV	<b>K650S1</b>	2 <sup>15</sup> / <sub>16</sub> "	N2,5,11,14,15 N2,5,12,14,16 N3,5,11,14,15
	600 A Short Shank Bushing w.o./stud	35kV	<b>750S1</b>		
	600 A Cu Short Shank Bushing w.o./stud	15/25kV	<b>K675S1</b>		
	600 A Long Shank Bushing w.o./stud	15/25kV	<b>K650T1</b>	8 <sup>9</sup> / <sub>16</sub> "	N2,5,11,14,15 N3,5,11,14,15 N2,5,12,14,16 N2,5,12,14,16
	600 A Cu Long Shank Bushing w.o./stud	15/25kV	<b>K675T1</b>	8 <sup>9</sup> / <sub>16</sub> "	
	600 A Long Shank Bushing w.o./stud	35kV	<b>750T1</b>	8 <sup>9</sup> / <sub>16</sub> "	
	600 A 12" Long Shank Bushing w.o./stud	35kV	<b>750L12</b>	12"	
	600 A In-Air Long Shank Bushing w.o./stud	15/25kV	<b>K650TBC</b>	8 <sup>9</sup> / <sub>16</sub> "	N2,4,11,6,14 N3,5,11,6,14 N6
	600 A Cu In-Air Long Shank Bush. w/stud	15/25kV	<b>K675TBC</b>		
	Boot & Collars for K600T1 to use in air	15/25kV	<b>600BC</b>		

- N1. Replacement stud available separately. Specify 1601RS.
- N2. Equipped with standard aluminum conductor rod.
- N3. Equipped with copper conductor rod.
- N4. Includes 5/8-11 threaded stud at elbow end.
- N5. Includes 5/8-11 threaded hole at elbow end.
- N6. Provides increased creep and strike.
- N7. Includes 1601PPC1 shipping cap.
- N8. Includes 1601APC1 shipping cap.
- N9. Includes 2701-41 shipping cap.
- N10. Includes 180PPC shipping cap.

- N11. Includes 650PPC shipping cap.
- N12. Includes 750PPC1 shipping cap.
- N13. Parking stands for 200A deadbreak applications are available as separate items. Specify 151PS.
- N14. Parking stands for 200A loadbreak and 600A deadbreak applications are available as separate items. Specify 160PS.
- N15. Aluminum stud available separately. Specify 650SA.
- N16. Copper stud available separately. Specify 750SA.

REFERENCE SECTION

How to Specify Size-Sensitive Products ..... 32-33

AEIC & ICEA Cable Insulation Diameter ..... 34-36

Cable Conductor Diameter ..... 37

WX Size Tables ..... 38-39

Index..... 40-41

Reference

PN \_ \_ \_ - **W**X - \_ \_ \_

Determines Size of Molded Rubber Part

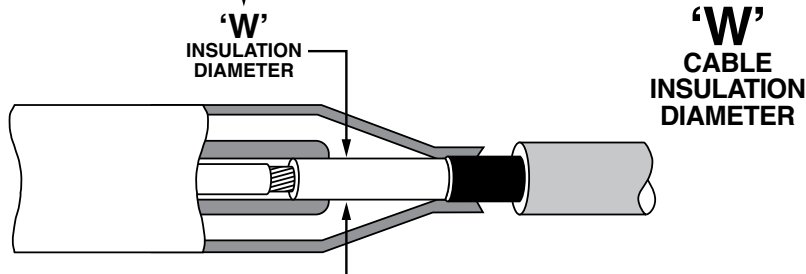

### INSULATION DIAMETER SELECTION GUIDE

Elastimold Elbows, cable joints and terminations are designed for application on XLP, EPR and other solid dielectric insulated power cables. These components are constructed of molded elastomer and rely on an interference fit with the cable insulation diameter in order to maintain proper dielectric strength, creep path integrity and a water seal. Elastimold components are available in a wide range of sizes in order to accommodate a variety of cable insulation diameters.

Selection of size-sensitive components requires determining the cable insulation diameter. This can be done in several ways:

- A. Refer to the cable manufacturer's spec sheet for dimensions.
- B. Measure the cable.
- C. If the cable conforms to AEIC or ICEA standards and is:
  1. 15kV, 175 mil wall thickness, use the table on page 34.
  2. 15kV, 220 mil wall thickness, use the table on page 35.
  3. 25kV, 260 mil wall thickness, use the table on page 35.
  4. 35kV, 345 mil wall thickness, use the table on page 36.

After the cable insulation diameter minimum and maximum has been determined:

1. Locate the W table indicated in the part number selection chart.
2. Complete the ordering information by selecting and inserting the symbol (given in the W table) into the part number.

### ORDERING EXAMPLES

#### AEIC

To complete the information required to order a K655LR-W0X elbow for use on standard AEIC 1000 kcmil compressed stranding aluminum 25kV cable with .260 inch thick insulation wall:

- A. Determine that the insulation diameter (for AEIC cable in the table on pages 34-36) is 1.645 – 1.770 inches.
- B. For this elbow, the part number selection chart on page 11 indicates to use table W7 for elbow sizing and table X6 for connector sizing.
- C. From table W7 the symbol for W is **N**.
- D. From table X6 the symbol for X is **410**.
- E. The completed part number therefore is **K655LR-N0410**.

#### ICEA

To complete the information required to order a K655LR-W0X elbow for use on standard ICEA 1000 kcmil compressed stranding aluminum 25kV cable with .260 inch thick insulation wall:

- A. Determine that the insulation diameter (for ICEA cable in the table on pages 34-36) is 1.645 – 1.740 inches.
- B. For this elbow, the part number selection chart on page 11 indicates to use table W7 for elbow sizing and table X6 for connector sizing.
- C. From table W7 the symbol for W is **N**.
- D. From table X6 the symbol for X is **410**.
- E. The completed part number therefore is **K655LR-N0410**.

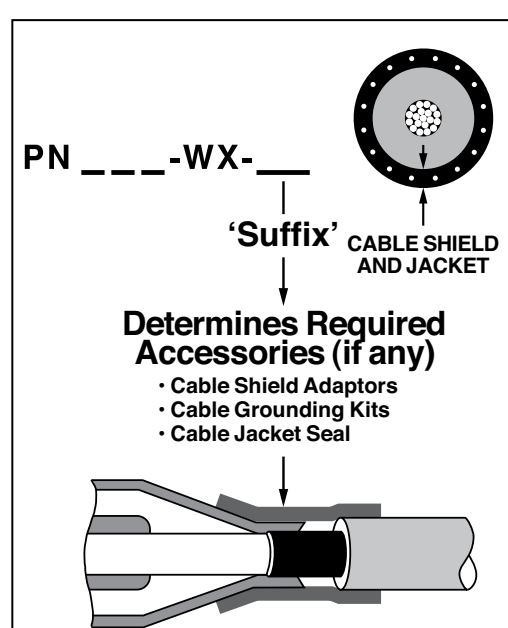
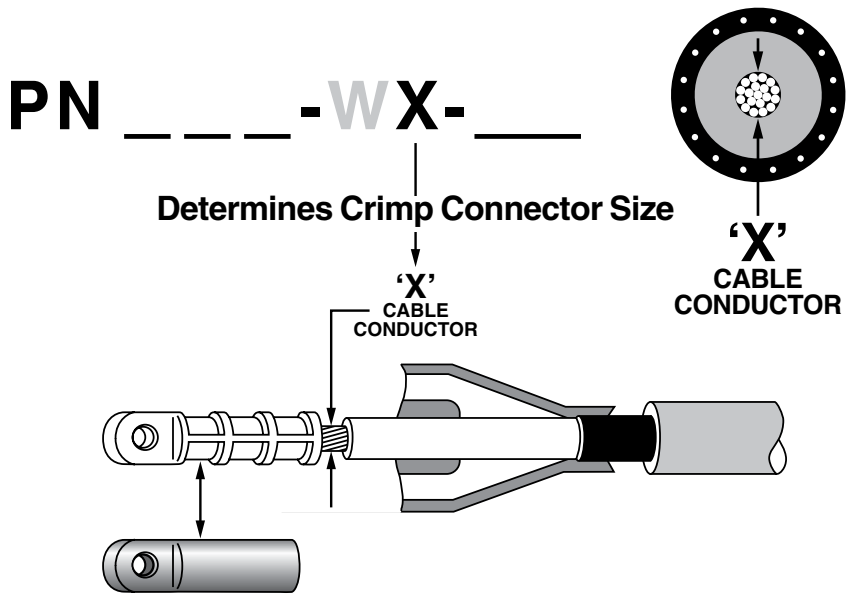

### CONNECTOR SELECTION GUIDE

Elastimold elbows, cable joints and terminations are furnished with crimp style cable connectors. As standard, these connectors are constructed with a tin-plated aluminum barrel filled with an oxide inhibitor. Most aluminum barrel connectors are universal and are designed for use on either aluminum or copper conductor cable.

When specified, all copper crimp style connectors can be furnished. These connectors are **ONLY** for use on copper conductor cable and are not for use with aluminum conductor cables. Bi-metallic connectors are constructed with a copper top and an aluminum barrel. Bi-metal connectors can be used on either aluminum or copper conductor cable and are furnished as standard with 200 Amp Loadbreak Elbows, 200 Amp Deadbreak Elbows, and PCT, 16 THG or MTG terminators with rod connectors.

**Aluminum connectors used in PCJ Cable Joints are rated as follows:**

- Aluminum conductor to aluminum conductor, cable rated
- Aluminum conductor to copper conductor, cable rated equal to the aluminum cable

**Copper connectors used in PCJ Cable Joints are rated as follows:**

- Copper conductor to copper conductor, cable rated

Selection and ordering the proper crimp connector requires determining information relative to the cable conductor as follows:

- Conductor size in AWG or kcmil
- Conductor type (stranded, compressed, compact or solid)
- Conductor material (aluminum or copper)

After the cable conductor information has been determined:

- Locate the X table indicated in the part number selection chart.
- Complete the ordering information by selecting and inserting the symbol (given in the X table) into the part number.

See the Ordering Example on page 32 for further information.

Reference Pages 28 & 29 for application, selection and ordering information.

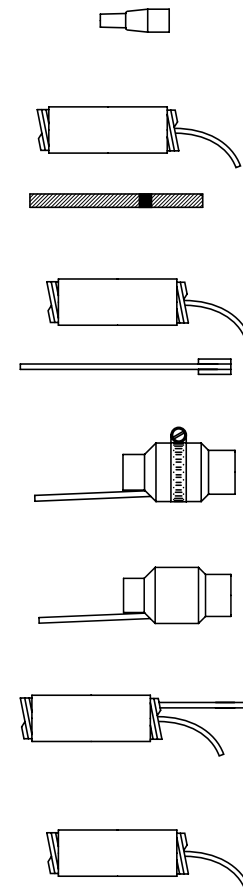

- 15kV 100% – 175 mil Insulation (.175")
- 15kV 133% – 220 mil Insulation (.220")
- 25kV 100% – 260 mil Insulation (.260")
- 35kV 100% – 345 mil Insulation (.345")

### AEIC CS8-06

Specification for Extruded Dielectric,  
Shielded Power Cable Rated 5 - 46kV

AEIC-Calculated Diameters - Solid and Compressed Stranding from  
Tables C-4 & C-6 and Compact Stranding from Tables C-5 & C-7

### ANSI/ICEA S-94-649-2004 & S-97-682-2000

Standard for Concentric Neutral Cables &  
Utility Shielded Power Cables Rated 5 - 46kV

ICEA-Concentric Stranding Table C-3, Compressed Stranding  
Table C-4, Compact Stranding Table C-5

*ICEA Abbreviated, for additional cables please refer to the standard.*

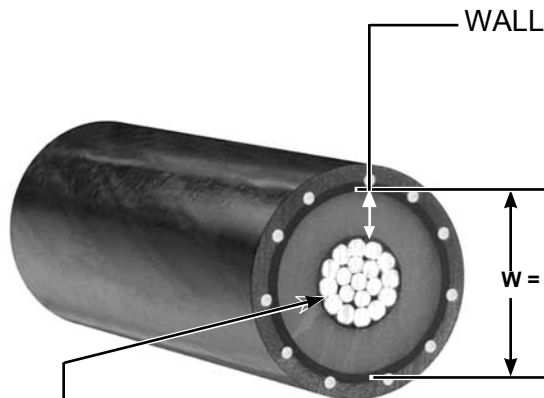

$$W = \text{Insulation Diameter (Conductor + 2 X Conductor Shield + 2 X wall)}$$

Reference

### 15kV Cable (100% level, 175 mil)

Aluminum & Copper Conductor Size	Industry Standard	Solid Conductor		Stranded Conductor		Compressed Conductor		Compact Conductor	
		Diameter in Inches Over Insulation		Diameter in Inches Over Insulation		Diameter in Inches Over Insulation		Diameter in Inches Over Insulation	
		Min.	Max.	Min.	Max.	Min.	Max.	Min.	Max.
#2	AEIC	0.610	0.700	-	-	0.635	0.725	0.620	0.710
	ICEA	0.610	0.695	0.645	0.730	0.635	0.720	0.620	0.705
#1	AEIC	0.645	0.730	-	-	0.675	0.765	0.655	0.740
	ICEA	0.645	0.725	0.685	0.770	0.675	0.760	0.655	0.735
1/0	AEIC	0.680	0.770	-	-	0.715	0.805	0.690	0.775
	ICEA	0.680	0.760	0.725	0.810	0.715	0.800	0.690	0.775
2/0	AEIC	-	-	-	-	0.760	0.850	0.730	0.815
	ICEA	-	-	0.775	0.855	0.760	0.845	0.730	0.815
3/0	AEIC	-	-	-	-	0.810	0.900	0.775	0.865
	ICEA	-	-	0.825	0.905	0.810	0.895	0.775	0.860
4/0	AEIC	-	-	-	-	0.865	0.955	0.830	0.915
	ICEA	-	-	0.880	0.965	0.865	0.950	0.830	0.910
250	AEIC	-	-	-	-	-	-	-	-
	ICEA	-	-	0.935	1.020	0.920	1.005	0.880	0.965
350	AEIC	-	-	-	-	1.025	1.115	0.980	1.065
	ICEA	-	-	1.045	1.130	1.025	1.110	0.980	1.065
500	AEIC	-	-	-	-	1.150	1.245	1.100	1.185
	ICEA	-	-	1.175	1.260	1.150	1.235	1.100	1.185
750	AEIC	-	-	-	-	1.340	1.440	1.280	1.370
	ICEA	-	-	1.370	1.455	1.340	1.425	1.280	1.365
1000	AEIC	-	-	-	-	1.485	1.590	1.430	1.520
	ICEA	-	-	1.520	1.610	1.485	1.575	1.430	1.515

ICEA NOTE: Diameters specified in the above table are different than specified by AEIC CS8-00. Consult Accessory Manufacturer for proper selection of accessories. Diameters to be measured in accordance with 9.6.

### 15kV Cable (133% level, 220 mil)

Aluminum & Copper Conductor Size	Industry Standard	Solid Conductor		Stranded Conductor		Compressed Conductor		Compact Conductor	
		Diameter in Inches Over Insulation		Diameter in Inches Over Insulation		Diameter in Inches Over Insulation		Diameter in Inches Over Insulation	
		Min.	Max.	Min.	Max.	Min.	Max.	Min.	Max.
#2	AEIC	0.700	0.790	–	–	0.725	0.815	0.710	0.800
	ICEA	0.700	0.790	0.735	0.825	0.725	0.815	0.710	0.800
#1	AEIC	0.735	0.820	–	–	0.765	0.855	0.745	0.830
	ICEA	0.735	0.820	0.775	0.865	0.765	0.855	0.745	0.830
1/0	AEIC	0.770	0.860	–	–	0.805	0.895	0.780	0.865
	ICEA	0.770	0.855	0.815	0.905	0.805	0.895	0.780	0.865
2/0	AEIC	–	–	–	–	0.850	0.940	0.820	0.905
	ICEA	–	–	0.865	0.950	0.850	0.935	0.820	0.905
3/0	AEIC	–	–	–	–	0.900	0.990	0.865	0.955
	ICEA	–	–	0.915	1.000	0.900	0.985	0.865	0.955
4/0	AEIC	–	–	–	–	0.955	1.045	0.920	1.005
	ICEA	–	–	0.970	1.060	0.955	1.045	0.920	1.005
250	AEIC	–	–	–	–	–	–	–	–
	ICEA	–	–	1.025	1.115	1.010	1.100	0.970	1.060
350	AEIC	–	–	–	–	1.115	1.205	1.070	1.155
	ICEA	–	–	1.135	1.220	1.115	1.200	1.070	1.155
500	AEIC	–	–	–	–	1.240	1.335	1.190	1.275
	ICEA	–	–	1.265	1.355	1.240	1.330	1.190	1.275
750	AEIC	–	–	–	–	1.430	1.530	1.370	1.460
	ICEA	–	–	1.460	1.550	1.430	1.520	1.370	1.460
1000	AEIC	–	–	–	–	1.575	1.680	1.520	1.610
	ICEA	–	–	1.610	1.705	1.575	1.670	1.520	1.610

Reference

### 25kV Cable (100% level, 260 mil)

Aluminum & Copper Conductor Size	Industry Standard	Solid Conductor		Stranded Conductor		Compressed Conductor		Compact Conductor	
		Diameter in Inches Over Insulation		Diameter in Inches Over Insulation		Diameter in Inches Over Insulation		Diameter in Inches Over Insulation	
		Min.	Max.	Min.	Max.	Min.	Max.	Min.	Max.
#1	AEIC	0.805	0.900	–	–	0.835	0.935	0.815	0.910
	ICEA	0.805	0.895	0.845	0.935	0.835	0.925	0.815	0.905
1/0	AEIC	0.840	0.940	–	–	0.875	0.975	0.850	0.945
	ICEA	0.840	0.930	0.885	0.980	0.875	0.965	0.850	0.940
2/0	AEIC	–	–	–	–	0.920	1.020	0.890	0.985
	ICEA	–	–	0.935	1.025	0.920	1.010	0.890	0.980
3/0	AEIC	–	–	–	–	0.970	1.070	0.935	1.035
	ICEA	–	–	0.985	1.075	0.970	1.060	0.935	1.030
4/0	AEIC	–	–	–	–	1.025	1.125	0.990	1.085
	ICEA	–	–	1.040	1.135	1.025	1.115	0.990	1.080
250	AEIC	–	–	–	–	–	–	–	–
	ICEA	–	–	1.095	1.190	1.080	1.175	1.040	1.135
350	AEIC	–	–	–	–	1.185	1.295	1.140	1.245
	ICEA	–	–	1.205	1.295	1.185	1.275	1.140	1.230
500	AEIC	–	–	–	–	1.310	1.425	1.260	1.365
	ICEA	–	–	1.335	1.430	1.310	1.405	1.260	1.350
750	AEIC	–	–	–	–	1.500	1.620	1.440	1.550
	ICEA	–	–	1.530	1.625	1.500	1.595	1.440	1.535
1000	AEIC	–	–	–	–	1.645	1.770	1.590	1.700
	ICEA	–	–	1.680	1.775	1.645	1.740	1.590	1.685

ICEA NOTE: Diameters specified in the above tables are different than specified by AEIC CS8-00. Consult Accessory Manufacturer for proper selection of accessories. Diameters to be measured in accordance with 9.6.

### 35kV Cable (100% level, 345 mil)

Aluminum & Copper Conductor Size	Industry Standard	Solid Conductor		Stranded Conductor		Compressed Conductor		Compact Conductor	
		Diameter in Inches Over Insulation		Diameter in Inches Over Insulation		Diameter in Inches Over Insulation		Diameter in Inches Over Insulation	
		Min.	Max.	Min.	Max.	Min.	Max.	Min.	Max.
1/0	AEIC	1.010	1.110	–	–	1.045	1.145	1.020	1.115
	ICEA	1.010	1.110	1.055	1.155	1.045	1.145	1.020	1.120
2/0	AEIC	–	–	–	–	1.090	1.190	1.060	1.155
	ICEA	–	–	1.105	1.200	1.090	1.190	1.060	1.160
3/0	AEIC	–	–	–	–	1.140	1.240	1.105	1.205
	ICEA	–	–	1.155	1.255	1.140	1.240	1.105	1.205
4/0	AEIC	–	–	–	–	1.195	1.295	1.160	1.255
	ICEA	–	–	1.210	1.310	1.195	1.295	1.160	1.260
250	AEIC	–	–	–	–	–	–	–	–
	ICEA	–	–	1.265	1.370	1.250	1.350	1.210	1.315
350	AEIC	–	–	–	–	1.355	1.470	1.310	1.420
	ICEA	–	–	1.375	1.475	1.355	1.455	1.310	1.410
500	AEIC	–	–	–	–	1.480	1.600	1.430	1.540
	ICEA	–	–	1.505	1.605	1.480	1.580	1.430	1.530
750	AEIC	–	–	–	–	1.670	1.795	1.610	1.725
	ICEA	–	–	1.700	1.800	1.670	1.770	1.610	1.710
1000	AEIC	–	–	–	–	1.815	1.945	1.760	1.875
	ICEA	–	–	1.850	1.955	1.815	1.920	1.760	1.865

ICEA NOTE: Diameters specified in the above table are different than specified by AEIC CS8-00. Consult Accessory Manufacturer for proper selection of accessories. Diameters to be measured in accordance with 9.6.

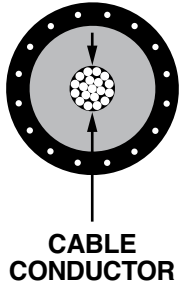

**Conductor Diameters for Copper and Aluminum (Class B)  
Stranded, Compressed, Compact and Solid Cables**

Conductor Size AWG or kcmil	No. of Strands and their Nom. Strand Dia. (in.)	Cross-sectional Area		Stranded Conductors (Inches)	Compressed Conductors (Inches)	Compact Conductors (Inches)	Solid Conductors (Inches)
		Square Inches	mm <sup>2</sup> Conversion				
<b>14</b>	7 x .0242	.0032	2.08	.073	—	—	.064
<b>12</b>	7 x .0305	.0051	3.31	.092	—	—	.081
<b>10</b>	7 x .0385	.0082	5.26	.116	—	—	.102
<b>8</b>	7 x .0486	.0130	8.37	.146	—	—	.129
<b>6</b>	7 x .0612	.0206	13.30	.184	—	—	.162
<b>4</b>	7 x .0772	.0328	21.15	.232	—	—	.204
<b>2</b>	7 x .0974	.0521	33.62	.292	.283	.268	.258
<b>1</b>	19 x .0664	.0657	42.41	.332	.322	.299	.289
<b>1/0</b>	19 x .0745	.0829	53.49	.373	.362	.336	.325
<b>2/0</b>	19 x .0837	.1054	67.43	.418	.405	.376	—
<b>3/0</b>	19 x .0940	.1318	85.01	.470	.456	.423	—
<b>4/0</b>	19 x .1055	.1662	107.2	.528	.512	.475	—
<b>250</b>	37 x .0822	.1964	127	.575	.558	.520	—
<b>350</b>	37 x .0973	.2749	177	.681	.661	.616	—
<b>500</b>	37 x .1162	.3924	253	.813	.789	.736	—
<b>600</b>	61 x .0992	.4712	304	.893	.866	.813	—
<b>700</b>	61 x .1071	.5498	355	.964	.935	.877	—
<b>750</b>	61 x .1109	.5890	380	.998	.968	.908	—
<b>800</b>	61 x .1145	.6283	405	1.031	1.000	.938	—
<b>900</b>	61 x .1215	.7069	456	1.094	1.061	.999	—
<b>1000</b>	61 x .1280	.7854	507	1.152	1.117	1.060	—
<b>1100</b>	91 x .1099	.8639	557	1.209	1.173	—	—
<b>1200</b>	91 x .1148	.9425	608	1.263	1.225	—	—
<b>1250</b>	91 x .1172	.9818	633	1.289	1.250	—	—
<b>1300</b>	91 x .1195	1.021	659	1.315	1.276	—	—
<b>1400</b>	91 x .1240	1.100	709	1.364	1.323	—	—
<b>1500</b>	91 x .1284	1.178	760	1.412	1.370	—	—
<b>1600</b>	127 x .1122	1.257	811	1.459	1.415	—	—
<b>1700</b>	127 x .1157	1.335	861	1.504	1.459	—	—
<b>1750</b>	127 x .1174	1.374	887	1.526	1.480	—	—
<b>1800</b>	127 x .1191	1.414	912	1.548	1.502	—	—
<b>1900</b>	127 x .1223	1.492	963	1.590	1.542	—	—
<b>2000</b>	127 x .1225	1.571	1010	1.632	1.583	—	—

Reference

Table W1 USE FOR FOLLOWING PRODUCTS 165/166LR 165/166LRJS	Cable Insulation Diameter in Inches		Symbol for W
	MIN.	MAX.	
	.575	.740	A
	.635	.905	B
	.830	1.060	C
	.930	1.220	D

Table W1A USE FOR FOLLOWING PRODUCTS 151SP/SR 151LS/LY	Cable Insulation Diameter in Inches		Symbol for W
	MIN.	MAX.	
	.575	.740	A
	.635	.905	B
	.805	1.060	C
	.890	1.220	D

Table W2 USE FOR FOLLOWING PRODUCTS 273RLR 274RLR	Cable Insulation Diameter in Inches		Symbol for W
	MIN.	MAX.	
	.760	.950	G
	.850	1.050	H
	.980	1.180	J
	1.090	1.310	K

Table W3 USE FOR FOLLOWING PRODUCTS 375RLR 376RLR	Cable Insulation Diameter in Inches		Symbol for W
	MIN.	MAX.	
	.850	1.050	H
	.980	1.180	J
	1.090	1.310	K
	1.235	1.465	L

Table W4 USE FOR FOLLOWING PRODUCTS 156LR 167/168RLR 167LRT	Cable Insulation Diameter in Inches		Symbol for W
	MIN.	MAX.	
	.640	.820	F
	.760	.950	G
	.850	1.050	H
	.980	1.180	J
	1.090	1.310	K

Table W5 USE FOR FOLLOWING PRODUCTS 167/168ELR 273/274ELR	Cable Insulation Diameter in Inches		Symbol for W
	MIN.	MAX.	
	.665	.895	6689
	.740	.950	7495
	.880	1.100	88110
	1.090	1.310	K

Table W6 USE FOR FOLLOWING PRODUCTS 10EP 152EA 160CA* (*EB - FA Only)	Cable Insulation Diameter in Inches		Symbol for W
	MIN.	MAX.	
	.495	.585	EB
	.525	.635	EF
	.575	.685	FA
	.625	.735	FAB
	.675	.785	FB
	.725	.835	FG
	.775	.885	GA
	.825	.935	GAB
	.875	.985	GB

Table W7 USE FOR FOLLOWING PRODUCTS K656I/CY/CH K655/656LR K655/656SR 655/656LINK K655/656LINK 655/656ETP K655/656ETP 655/656RTP K655/656LRTP 655/656BI-LINK K655/656BI-LINK 655CA/CK/TCK	Cable Insulation Diameter in Inches		Symbol for W
	MIN.	MAX.	
	.640	.820	F
	.760	.950	G
	.850	1.050	H
	.980	1.180	J
	1.090	1.310	K
	1.180	1.465	L
	1.280	1.430	LM
	1.370	1.630	M
	1.515	1.780	N
	1.725	1.935	P

Table W8 USE FOR FOLLOWING PRODUCTS 15PCJ-1 15PCJ-2	Cable Insulation Diameter in Inches		Symbol for W
	MIN.	MAX.	
	.640	.820	F
	.760	.950	G
	.850	1.050	H
	.980	1.180	J
	1.090	1.310	K
	1.180	1.465	L
	1.280	1.430	LM
	1.370	1.630	M
	1.515	1.780	N
	1.725	1.935	P
	1.900	2.120	Q

Table W9 USE FOR FOLLOWING PRODUCTS 25PCJ-1 25PCJ-2 755/756LR 755/756LINK 755/756ETP 755/756LRTP 755/756BI-LINK 755CA/CK/TCK	Cable Insulation Diameter in Inches		Symbol for W
	MIN.	MAX.	
	.760	.950	G
	.850	1.050	H
	.980	1.180	J
	1.090	1.310	K
	1.180	1.465	L
	1.280	1.430	LM
	1.370	1.630	M
	1.515	1.780	N
	1.725	1.935	P
	1.900	2.120	Q

Table W10 USE FOR FOLLOWING PRODUCTS 35PCJ-1 35PCJ-2	Cable Insulation Diameter in Inches		Symbol for W
	MIN.	MAX.	
	.850	1.050	H
	.980	1.180	J
	1.090	1.310	K
	1.180	1.465	L
	1.280	1.430	LM
	1.370	1.630	M
	1.515	1.780	N
	1.725	1.935	P
	1.900	2.120	Q

Table W11 USE FOR FOLLOWING PRODUCTS 35MSC 35MSCI	Cable Insulation Diameter in Inches		Symbol for W
	MIN.	MAX.	
	.495	.585	EB
	.525	.635	EF
	.575	.685	FA
	.625	.735	FAB
	.675	.785	FB
	.725	.835	FG
	.775	.885	GA
	.825	.935	GAB
	.875	.985	GB
	.930	1.040	GH
	.980	1.115	HA
	1.040	1.175	HAB
	1.095	1.240	HB
	1.160	1.305	HJ
	1.220	1.375	JA
	1.285	1.395	JAB
	1.355	1.520	JB
	1.485	1.595	KA
	1.530	1.640	KAB
	1.575	1.685	KB
	1.665	1.785	PA
	1.755	1.875	PB

Table W12 USE FOR FOLLOWING PRODUCTS 16THG 16THGS 16THGH	Cable Insulation Diameter in Inches		Symbol for W
	MIN.	MAX.	
	.495	.585	EB
	.525	.635	EF
	.575	.685	FA
	.625	.735	FAB
	.675	.785	FB
	.725	.835	FG
	.775	.885	GA
	.825	.935	GAB
	.875	.985	GB
	.930	1.040	GH
	.980	1.115	HA

Table W16 USE FOR FOLLOWING PRODUCTS 275/276LR 275/276LRJS	Cable Insulation Diameter in Inches		Symbol for W
	MIN.	MAX.	
	.800	1.060	CC
	.940	1.170	DD

Please see page 26 for Table W13 and page 29 for Tables W14 and W15.

Table X1 USE FOR FOLLOWING PRODUCTS	Conductor Size AWG or kcmil	Symbol for X	
		Strand./ Compr.	Compt./ Solid.
167/168ELR	#4	200	190
273/274ELR	#3	210	200
156LR	#2	220	210
165/166LR	#1	230	220
275/276LR	1/0	240	230
167LRT	2/0	250	240
167/168RLR	3/0	260	250
273/274RLR	4/0	270	260
00400	250	—	270
02500			
02509			
02702			
02800			
K151SP/SR			
K151LS/LY			

Table X2 USE FOR FOLLOWING PRODUCTS	Conductor Size AWG or kcmil	Symbol for X	
		Strand./ Compr.	Compt./ Solid.
375/376LR	1/0	240	230
	2/0	250	240
	3/0	260	250
	4/0	270	260

Table X3 USE FOR FOLLOWING PRODUCTS	Conductor Size AWG or kcmil	Symbol for X	
		Strand./ Compr.	Compt./ Solid.
35MTG	#6	5	—
	#5	4	5
	#4	3	4
	#3	2	3
	#2	1	2
	#1	0	1
	1/0	10	0
	2/0	20	10
	3/0	30	20
	4/0	40	30
	250	250	40
	300	300	250
	350	350	300
	400	400	350
	450	450	—
	500	500	400
	550	550	450
	600	600	500
	650	650	550
	700	750	600
	750	750	650
	800	800	750
	900	900	800
	1000	1000	900

Table X3A USE FOR FOLLOWING PRODUCTS	Conductor Size AWG or kcmil	Symbol for X	
		Strand./ Compr.	Compt./ Solid.
35MTG	400	400	—
	450	450	400
	500	500	450
	550	550	500
	600	600	500
	650-700	650	550
	750	750	600
	800	750	650
	1000	1000	—

Table X4 USE FOR FOLLOWING PRODUCTS	Riser Conductor Size, AWG Solid	Symbol for X
16CAS	#1	2
	1/0	10
	2/0	20
	3/0	30
	4/0	30

Table X6 USE FOR FOLLOWING PRODUCTS	Conductor Size AWG or kcmil	Symbol for X	
		Strand./ Compr.	Compt./ Solid.
655/656LRTP	#2	220	210
K655/656LRTP	#1	230	220
755/756LRTP	1/0	240	230
K656I/Y/H	2/0	250	240
K655/656LR	3/0	260	250
755/756LR	4/0	270	260
K655/656SR	250	280	270
655/656LINK	300	290	280
K655/656LINK	350	300	290
755/756LINK	400	310	300
655/656ETP	450	320	310
K655/656ETP	500	330	320
755/756ETP	550	340	320
655/656BI-LINK	600	350	330
K655/656BI-LINK	650	360	340
755BI-LINK	700	380	350
655CK	750	380	360
755CK	800	390	360
655TCK	800	390	360
03600	900	400	380
03602	1000	410	400
03700	1250	440	420
03702			

Table X7 USE FOR FOLLOWING PRODUCTS	Conductor Size AWG or kcmil	Symbol for X	
		Strand./ Compr.	Compt./ Solid.
15PCJ1	#6	180	—
25PCJ1	#5	190	180
35PCJ1	#4	200	190
15PCJ2	#3	210	200
25PCJ2	#2	220	210
35PCJ2	#1	230	220
	1/0	240	230
	2/0	250	240
	3/0	260	250
	4/0	270	260
	250	280	270
	300	290	280
	350	300	290
	400	310	300
	450	320	310
	500	330	310
	550	340	320
	600	350	330
	650	360	340
	700	380	350
	750	380	360
	800	390	380
	900	400	380
	1000	410	400
	1250	440	420

Table X8 USE FOR FOLLOWING PRODUCTS	Conductor Size AWG or kcmil	Symbol for X	
		Strand./ Compr.	Compt./ Solid.
16THG	#6	180	—
16TCA	#5	190	180
	#4	200	190
	#3	210	200
	#2	220	210
	#1	230	220
	1/0	240	230
	2/0	250	240
	3/0	260	250
	4/0	270	260

Table X9 USE FOR FOLLOWING PRODUCTS	Conductor Size AWG or kcmil	Symbol for X	
		Strand./ Compr.	Compt./ Solid.
PCT1	#2	220	210
PCT2	#1	230	220
01000	1/0	240	230
01010	2/0	250	240
	3/0	260	250
	4/0	270	260

Reference WX Tables

Catalog Number	Page Number	Catalog Number	Page Number	Catalog Number	Page Number	Catalog Number	Page Number
00400X	7	160CA-W	7,9	25PCJ1LX	23	35MTB1-C	27
00700X	25	160DR	5	25PCJ1MX	23	35MTB1-D	27
01000X	25	160DRG	5	25PCJ1NX	23	35MTB3-A	27
01100X	25	160GLR	5,15,17	25PCJ1PX	23	35MTB3-B	27
02500X	7,9	161GP	5	25PCJ1QX	23	35MTB3-C	27
02509X	7	161SOP	5	25PCJ1W1X	23	35MTB3-D	27
02702X	7,9	164FT	5	25PCJ1W2X	23	35MTB4-A	27
02800X	7	164FT2-AB	5	25PCJ2GX	23	35MTB4-B	27
03600X	17	164FT3-AB	5	25PCJ2HX	23	35MTB4-C	27
03602X	17	164FT4-AB	5	25PCJ2JX	23	35MTB4-D	27
03700X	11,15,17,19	164FTV	5	25PCJ2KX	23	35MTB5-A	27
03702X	11,15,17,19	164J2	7	25PCJ2LX	23	35MTB5-B	27
10EP-W	7,9	164J2-5	7	25PCJ2MX	23	35MTB5-C	27
10TL-W	29	164J3	7	25PCJ2NX	23	35MTB5-D	27
150BA	9	164J3-5	7	25PCJ2PX	23	35MTGA-WX-1	25
150TB1	9	164J4	7	25PCJ2QX	23	35MTGA-WX-2	25
150TB2	9	164J4-5	7	25PCJ2W1X	23	35MTGA-WX-3	25
150TB3	9	164SOP	5	25PCJ2W2X	23	35MTGA-WX-4	25
150TB4	9	165LRJS-W5X	5	2701A4	5	35MTGI-W-4	25
150TB5	9	165LR-W5X	5	2701CABA4R	30	35MTGI-W-6	25
151GP	9	166LRF	7	2701EA4	5	35MTGI-W-8	25
152EA-W	9	166LRJS-W5X	5	2702A1	5	35MTG-WX-10-CA	25
1535AFB-1	27	166LR-W5X	5	272GP	5	35MTG-WX-4-CA	25
1535AFB-3	27	167DELR-W5X	5	272SOP	5	35MTG-WX-8-CA	25
1535AFB-4	27	167DLR-W5X	5	273DELR-W5X	5	35PCJ1HX	23
1535AFB-5	27	167DRG	5	273DLR-W5X	5	35PCJ1JX	23
156DLR-W5X	9	167ELR-W5X	5	273DRG	5	35PCJ1KX	23
156LRF	9	167LRT-W5X	5	273ELR-W5X	5	35PCJ1LX	23
156LR-W5X	9	167RLR-W5X	5	273RLR-W5X	5	35PCJ1MX	23
15PCJ1FX	23	168DELR-W5X	5	274DELR-W5X	5	35PCJ1NX	23
15PCJ1GX	23	168DRG	5	274DRG	5	35PCJ1PX	23
15PCJ1HX	23	168ELR-W5X	5	274ELR-W5X	5	35PCJ1QX	23
15PCJ1JX	23	168FLR H-W0X	5	274FLR H-W0X	5	35PCJ1W1X	23
15PCJ1KX	23	168RLR-W5X	5	274FT	5	35PCJ1W2X	23
15PCJ1LMX	23	16CAS-X	25	274FT2-AB	5	35PCJ2HX	23
15PCJ1LX	23	16TB-2	27	274FT3-AB	5	35PCJ2JX	23
15PCJ1MX	23	16TB-3	27	274FT4-AB	5	35PCJ2KX	23
15PCJ1NX	23	16TB-4	27	274FTV	5	35PCJ2LX	23
15PCJ1PX	23	16TB-5	27	274J2	7	35PCJ2MX	23
15PCJ1QX	23	16TCA-X	25	274J2-5	7	35PCJ2NX	23
15PCJ1W1X	23	16THGH-W	25	274J3	7	35PCJ2PX	23
15PCJ1W2X	23	16THGS-WX	25	274J3-5	7	35PCJ2QX	23
15PCJ2FX	23	16THG-WX-4	25	274J4	7	35PCJ2W1X	23
15PCJ2GX	23	200AT	5	274J4-5	7	35PCJ2W2X	23
15PCJ2HX	23	200ECS	29	274LRF	7	3701A3	5
15PCJ2JX	23	200ECSG1-2	29	274RLR-W5X	5	3701A4	5
15PCJ2KX	23	200ECSG2-2	29	274SOP	5	3702A1	5
15PCJ2LX	23	200ECSG3	29	275LRJS-W5X	5	370GLR	5,15,17
15PCJ2MX	23	200TC-1	7,11	275LR-W5X	5	370TR	5,15,17
15PCJ2NX	23	200TC-2	7,11	276BWP	5	371FT	5
15PCJ2PX	23	200TC-4	7,11	276LRJS-W5X	5	372SOP	5
15PCJ2QX	23	20MA-W	29	276LR-W5X	5	373FT	5
15PCJ2W1X	23	21MA-W	29	35AL-A	25	373FTV	5
15PCJ2W2X	23	25PCJ1GX	23	35MG-W	25	373J2	7
1601A4	5	25PCJ1HX	23	35MSCI-W	25	373J2-5	7
1601CABA4R	30	25PCJ1JX	23	35MSC-W	25	373J3	7
1601EA4	5	25PCJ1KX	23	35MTB1-A	27	373J3-5	7
1602A3R	5	25PCJ1LMX	23	35MTB1-B	27	373J4	7

Catalog Number	Page Number	Catalog Number	Page Number	Catalog Number	Page Number	Catalog Number	Page Number
373J4-5	7	750ETP	11,17	K150DR	9	K655BLR	11
375DRG	5	750GP	11	K150S	9	K655BRLR	11
375LR-W5X	5	750J2	13	K150SOP	9	K655BSR	11
375LRF	7	750J3	13	K150T	9	K655BVS	11
376DRG	5	750J4	13	K151LS-W1X	9	K655DLR-W0X	11
376LR-W5X	5	750L12	30	K151LY-W1X	9	K655DSR-W0X	11
600AT	15,17	750LB	15	K151S0P	9	K655ETP-W0X-DRG	17
600ATM	11,13,17	750LBM-3	15	K151SP-W0X	9	K655L1	13
600BC	30	750LINK-OK	15	K151SR-W0X	9	K655L2	13
600ECS	29	750LK-C-VB	15	K1601PCC-R	30	K655L3	13
600ECSG1-2	29	750LRTPA2	17	K1601PC-S1	30	K655L4	13
600ECSG2-2	29	750LT-B	15	K1601PC-S1-R	30	K655LINK-B-LR-W0X-A-DRG	15
600ECSG3	29	750S1	30	K1601PC-S2	30	K655LINK-B-LR-W0X-B-DRG	15
600RRT	19	750SA	11	K1601PC-S2-R	30	K655LINK-C-LR-W0X-A-DRG	15
600SW	11,13	750SOP	11	K1601PC-T1	30	K655LINK-C-LR-W0X-B-DRG	15
600YADT	19	750STICK-OK	17	K1601PC-T1-R	30	K655LRTP-W0X-DRG	17
650AB	15	750T1	30	K1601PC-T2	30	K655LR-W0X	11
650ABV	15	750VSA	11	K1601PC-T2-R	30	K655RETP	17
650ARR-X	11,19	750WINDOW-OK	17	K1601WFT	5	K655RLRTP	17
650BA	19	755BE	11	K1601WFTV	5	K655SR-W0X	11
650BAW	19	755BI-LINK-B-LR-W0X-DRG	15	K1601WJ2	7	K655VSL2	13
650BEA3	17	755BI-LINK-C-LR-W0X-DRG	15	K1601WJ2-5	7	K655VSL3	13
650CAB	15	755BLR	11	K1601WJ3	7	K655VSL4	13
650CAM-OK	15	755BVS	11	K1601WJ3-5	7	K655YBSR	19
650ET	17	755CA-W	11	K1601WJ4	7	K655YDR	19
650ETP	11,17	755CK-W0X	11,15,17	K1601WJ4-5	7	K655YDSR-W0X	19
650GP	11	755CK-W0X-ARR	11	K180C4	30	K655YSR-W0X	19
650GYDR	19	755DLR-W0X	11	K180S4	30	K656BLR	11
650LINK-OK	15	755ETP-W0X-DRG	17	K180T4	30	K656BRLR	11
650LK-C-VB	15	755L1	13	K650BEA2	17	K656CH-BUS	19
650LRTPA3	17	755L2	13	K650BIP	11	K656CH-HP	19
650LT-B	15	755L3	13	K650CAB	15	K656CH-W0X	19
650RS	15	755L4	13	K650CAM-OK	15	K656DLR-W0X	11
650RSC	15	755LINK-B-LR-W0X-A-DRG	15	K650CP	11	K656CY-BUS	19
650SA	11	755LINK-B-LR-W0X-B-DRG	15	K650ETP	11,17	K656CY-HP	19
650STICK-OK	17	755LINK-C-LR-W0X-A-DRG	15	K650J2	13	K656CY-W0X	19
650VSA	11	755LINK-C-LR-W0X-B-DRG	15	K650J3	13	K656DLR-W0X	11
650WINDOW-OK	17	755LRTP-W0X-DRG	17	K650J4	13	K656DR	11
650YGP	19	755LR-W0X	11	K650LB	15	K656I-BUS	19
655BI-LINK-B-LR-W0X-DRG	15	755TCK-W0X	17	K650LBM-3	15	K656I-HP	19
655BI-LINK-C-LR-W0X-DRG	15	755VSL2	13	K650LINK-OK	15	K656I-W0X	19
655CA-W	11,19	755VSL3	13	K650LK-C-VB	15	K656LR-W0X	11
655CK-W0X	11,15,17	755VSL4	13	K650LRTPA2	17	K656YDSR-W0X	19
655CK-W0X-ARR	11,19	756BLR	11	K650LT-B	15	K675S1	30
655ETP-W0X-DRG	17	756DLR-W0X	11	K650RTP	11	K675T1	30
655LINK-B-LR-W0X-A-DRG	15	756LR-W0X	11	K650RTW	11	K675TBC	30
655LINK-B-LR-W0X-B-DRG	15	J2	21	K650S1	30	L1601PC-S1	30
655LINK-C-LR-W0X-A-DRG	15	J3	21	K650SOP	11	L1601PC-S1-R	30
655LINK-C-LR-W0X-B-DRG	15	J4	21	K650SRA	11	L1601PC-S2	30
655LRTP-W0X-DRG	17	J5	21	K650STICK-OK	17	L1601PC-S2-R	30
655RETP	17	J6	21	K650T1	30	L1601PC-T1	30
655RLRTP	17	K1501A1	9	K650TBC	30	L1601PC-T1-R	30
655TCK-W0X	17	K1501FT	9	K650WINDOW-OK	17	L1601PC-T2	30
750BEA2	17	K1501J2-U	9	K650YBIP	19	L1601PC-T2-R	30
750BIP	11	K1501J3-U	9	K651CP	11	M276BWP	5
750CAB	15	K1501J4-U	9	K655BE	11	PB-1	27
750CAM-OK	15	K1502A1	9	K655BI-LINK-B-LR-W0X-DRG	15	PCT1-1X-4	25
750CP	11	K150DP	9	K655BI-LINK-C-LR-W0X-DRG	15	PCT1-4	25

Index



POWER DELIVERY



CABLE JOINTS, CABLE TERMINATIONS, CABLE GLANDS, CABLE CLEATS  
FEEDER PILLARS, FUSE LINKS, ARC FLASH, CABLE ROLLERS, CUT-OUTS

11KV 33KV CABLE JOINTS & CABLE TERMINATIONS  
FURSE EARTHING  
[www.cablejoints.co.uk](http://www.cablejoints.co.uk)  
**Thorne and Derrick UK**

Tel 0044 191 490 1547 Fax 0044 191 477 5371  
Tel 0044 117 977 4647 Fax 0044 117 9775582