



ENGINEERING INSTRUCTION

EI 02-0019

INSTALLATION OF UNDERGROUND CABLES - LV TO 132KV

Network(s): EPN, LPN, SPN

Summary: This engineering instruction details the minimum requirements acceptable for the installation of new LV, 11kV, 20kV, 33kV, 66kV and 132kV cables, plus associated pilot and telephone cables.

Originator: Paul Williams **Date:** 03/11/2005

Approved By: Paul Eaves **Approved Date:** 03/11/2005

Review Date: 03/11/2008

This document forms part of the Company's Integrated Business System and its requirements are mandatory throughout EDF Energy Networks Branch. Departure from these requirements may only be taken with the written approval of Asset Management. If you have any queries about this document please contact the originator of the current issue.

Document History

(The document history notes below are intended as a guide only and may not cover all of the changes. If you wish to make use of this document it should be read in full.)

Version	Date	Details	Originator
06	24/10/2005	Re-written for all EDF Energy networks	Paul Williams

Contents

1	Scope	4
2	References	4
3	General Requirements	4
4	On Site Requirements	4
4.1	Street Works	4
4.2	Plans and Records	4
5	Cable Types for New Installations	5
5.1	Direct Buried Installations	5
5.1.1	LV Service Cables	5
5.1.2	LV Mains Cables	5
5.1.3	11kV Cables	6
5.1.4	20kV Cables	6
5.1.5	33kV Cables	6
5.1.6	66kV Cables	7
5.1.7	132kV Cables	7
5.1.8	Auxiliary Multi-core and Multi-pair cables	7
5.2	In Air Installations	7
5.2.1	LV Service Cables	7
5.2.2	LV Mains Cables	8
5.2.3	11kV Cables	8
5.2.4	20kV Cables	8
5.2.5	33kV Cables	9
5.2.6	66kV Cables	9
5.2.7	132kV Cables	9
5.2.8	Auxiliary Multi-core and Multi-pair cables	9
5.3	Joint Bays	9
6	Cable Installation Depths	9
6.1	Low Voltage Service and Mains Cables	10
6.2	11 and 20kV Cables	12
6.3	33kV Cables	14
6.4	66 and 132kV Cables	16
6.5	Auxiliary Multi-core and Multi-pair Cables	18
6.6	Typical Trench Layouts	18
7	Cable Installation	23
7.1	Trench Bedding	23

7.2	Cable Ducts.....	23
7.3	Cable Drums	23
7.4	Pulling Cable	24
7.5	Blinding Cables	25
7.6	Cable Protection Covers	25
8	Trenchless Installation	25
8.1	General	25
	Appendix A – Cable Maximum Pulling Tensions	27
A.1	Maximum cable pulling tensions, minimum duct dimensions and minimum bending radii for LV and 11KV Cables.....	27
A.2	Maximum Cable Pulling Tensions and Minimum Bending Radii for 20kV Cables	27
A.3	Maximum Cable Pulling Tensions and Minimum Bending Radii for 33kV Cables	28
A.4	Maximum Cable Pulling Tensions and Minimum Bending Radii for Multi-core and Multi-pair Cables	28

1 Scope

This Engineering Instruction covers the minimum requirements for the installation of new low voltage, pilot and telephone, 11kV, 20kV, 33kV, 66kV and 132kV cables and the types of cable that shall be installed in particular operating environments.

2 References

This Engineering Instruction makes reference to the current issue of the following documents at the time of tendering:

EDF Energy Documents

EDF Energy Distribution Safety Rules (DSR) & associated Codes of Practice

EI 02-0031 Protecting 11kV Cables and Joints installed in air from Fire and Mechanical Damage

EI 09-0059 Street Works Management Policy

EI 09-0100 Process for the Site Recording of Cables, Plant and Equipment

ES 2-0526 Plastic Ducts for Buried Cables

ES 2-1000 Cable Protection Covers

SHE 101-WMS-01 Safety, Health & Environmental Specific Work Method Cable/Duct Laying, Pulling

SHE 101-WMS-02 Safety, Health & Environmental Specific Work Method Excavation & Streetworks

3 General Requirements

The general requirements of this Engineering Instruction are as follows:

- a) Guidance on the types of cable that shall be installed in different operating environments;
- b) Minimum acceptable depths of cover for all types of new cable;
- c) Installation guidelines for new cables and cable ducts;
- d) Installation guidelines of new cable marker tape and stokboards;

4 On Site Requirements

4.1 Street Works

All staff and subcontractors employed to carry out the works described in this engineering instruction shall comply with the requirements of EI 09-0059 EDF Energy's Street Works Management Policy.

4.2 Plans and Records

On completion of all works as-built drawings shall be provided as laid down in EI 09-0100 EDF Energy's process for the Site Recording of Cables, Plant and Equipment.

5 Cable Types for New Installations

5.1 Direct Buried Installations

Only the following types of cable shall be permanently installed either directly in the ground or in cable ducts:

If it is necessary to install any of these types of cable in an in-air environment (i.e. a cable pit or cable basement), for short distances, it shall be protected with one of the methods described in Engineering Instruction EI 02-0031 Protecting 11kV Cables and Joints installed in air from Fire and Mechanical Damage.

5.1.1 LV Service Cables

The following table details the sizes and types of Concentric and Split Concentric cable with black PVC sheaths that shall be used in direct buried or ducted situations:

Cable Type	Conductor Size	EDF Energy SAP Commodity Code		
		EPN	LPN	SPN
Single Phase Concentric	4 mm ² Copper	N/A	05160G	05860K
Single Phase Concentric	16 mm ² Aluminium	05574K	N/A	N/A
Single Phase Concentric	35 mm ² Aluminium	05455U	05176Y	05886L
Three Phase Concentric	35 mm ² Aluminium	05602M	05177J	05903U
Single Phase Split Concentric	25 mm ² Copper	05884R		

5.1.2 LV Mains Cables

The following table details the sizes and types of Waveform cable with a black PVC sheath that shall be used in direct buried or ducted situations:

Cable Type	Conductor Size	EDF Energy SAP Commodity Code		
		EPN	LPN	SPN
Three Phase Waveform	95 mm ² Aluminium	05577P	05150X	05577P
Three Phase Waveform	185 mm ² Aluminium	05579J	05151H	05906Y
Three Phase Waveform	300 mm ² Aluminium	05599H	05152S	05907J

5.1.3 11kV Cables

The following table details the sizes and types of Triplex and Single Core XLPE cable with a red Polyethylene outer sheath that shall be used in direct buried or ducted situations:

Cable Type	Conductor Size	EDF Energy SAP Commodity Code
Triplex	95 mm ² Aluminium	06000B
Triplex	185 mm ² Aluminium	06001L
Triplex	300 mm ² Aluminium	06002V
Triplex	300 mm ² Copper	06003F*
Single Core	400 mm ² Copper	06020T*
Single Core	500 mm ² Copper	06021D*
Single Core	630 mm ² Copper	06022N*
Single Core	800 mm ² Copper	06023X*

* Available as a non-stock item from EDF Energy Supply Chain.

5.1.4 20kV Cables

The following table details the sizes and types of Triplex XLPE cable with a red Polyethylene outer sheath that shall be used in direct buried or ducted situations:

Cable Type	Conductor Size	EDF Energy SAP Commodity Code
Triplex	300 mm ² Copper	06060D*

* Available as a non-stock item from EDF Energy Supply Chain.

5.1.5 33kV Cables

The following table details the sizes and types of Single Core XLPE cable with a red Polyethylene outer sheath that shall be used in direct buried or ducted situations:

Cable Type	Conductor Size	EDF Energy SAP Commodity Code
Single Core	185 mm ² Copper	06100J*
Single Core	300 mm ² Copper	06101T*
Single Core	400 mm ² Copper	06102D*
Single Core	500 mm ² Copper	06103N*
Single Core	630 mm ² Copper	06104X*
Single Core	800 mm ² Copper	06105H*

* Available as a non-stock item from EDF Energy Supply Chain.

5.1.6 66kV Cables

Single core XLPE cables with a black Polyethylene outer sheath shall be used which fully comply with EDF Energy Equipment Specification ES 2-0990. These are generally purchased on a project by Project basis.

5.1.7 132kV Cables

Single core XLPE cables with a black Polyethylene outer sheath shall be used which fully comply with EDF Energy Equipment Specification ES 2-4000. These are generally purchased on a project by Project basis.

5.1.8 Auxiliary Multi-core and Multi-pair cables

Multi-core and Multi-pair cables with black PVC outer sheaths shall be used which fully comply with EDF Energy Equipment Specification ES 2-0950. These are generally purchased on a project by Project basis.

5.2 In Air Installations

Only the following types of cable shall be permanently installed in cable tunnels, cable basements and other situation where the cable is exposed to the air:

In these situations cable joints should only be installed as a last resort, but if required these shall be fitted with the appropriate flame retardant materials as detailed in EI 02-0031 Protecting 11kV Cables and Joints installed in air from Fire and Mechanical Damage.

5.2.1 LV Service Cables

The following table details the sizes and types of Concentric and Split Concentric cable with an orange flame retardant sheath that shall be permanently installed in cable tunnels, cable basements and other situation where the cable is exposed to the air:

Cable Type	Conductor Size	EDF Energy SAP Commodity Code
Single Phase Concentric	35 mm ² Aluminium	05550D
Three Phase Concentric	35 mm ² Aluminium	05552X
Single Phase Split Concentric	25 mm ² Copper	N/A*

- Available as a non-stock item from EDF Energy Supply Chain.

5.2.2 LV Mains Cables

The following table details the sizes and types of Waveform cable with an orange flame retardant sheath that shall be permanently installed in cable tunnels, cable basements and other situation where the cable is exposed to the air:

Cable Type	Conductor Size	EDF Energy SAP Commodity Code
Three Phase Waveform	95 mm ² Aluminium	05594C*
Three Phase Waveform	185 mm ² Aluminium	05595M*
Three Phase Waveform	300 mm ² Aluminium	05596W*

* Available as a non-stock item from EDF Energy Supply Chain.

5.2.3 11kV Cables

The following table details the sizes and types of Single Core XLPE cable with a red flame retardant outer sheath that shall be permanently installed in cable tunnels, cable basements and other situation where the cable is exposed to the air:

Cable Type	Conductor Size	EDF Energy SAP Commodity Code
Single Core	95 mm ² Aluminium	06004Q
Single Core	185 mm ² Aluminium	06005A
Single Core	300 mm ² Aluminium	06006K
Single Core	300 mm ² Copper	06007U*
Single Core	400 mm ² Copper	06024H*
Single Core	500 mm ² Copper	06025S*
Single Core	630 mm ² Copper	06026C*
Single Core	800 mm ² Copper	06027M*

* Available as a non-stock item from EDF Energy Supply Chain.

5.2.4 20kV Cables

The following table details the sizes and types of Single Core XLPE cable with a red flame retardant outer sheath that shall be permanently installed in cable tunnels, cable basements and other situation where the cable is exposed to the air:

Cable Type	Conductor Size	EDF Energy SAP Commodity Code
Triplex	300 mm ² Copper	06061N*

* Available as a non-stock item from EDF Energy Supply Chain.

5.2.5 33kV Cables

Single core XLPE cables with a red flame retardant outer sheath shall be used which fully comply with EDF Energy Equipment Specification ES 2-0905. These are generally purchased on a project by project basis.

5.2.6 66kV Cables

Single core XLPE cables with a black flame retardant outer sheath shall be used which fully comply with EDF Energy Equipment Specification ES 02-0995. These are generally purchased on a project by project basis.

5.2.7 132kV Cables

Single core XLPE cables with a black flame retardant outer sheath shall be used which fully comply with EDF Energy Equipment Specification ES 02-0404. These are generally purchased on a project by project basis.

5.2.8 Auxiliary Multi-core and Multi-pair cables

Multi-core and multi-pair cables with black flame retardant outer sheaths shall be used which fully comply with EDF Energy Equipment Specification ES 02-0950. These are generally purchased on a project by project basis.

5.3 Joint Bays

Where reasonably practicable, all exposed cables and joints in joint bays shall be blinded with sand or covered with sand bags, before they are being energised, to protect them against mechanical damage and to prevent the possible spread of fire.

In situations where this is not possible consideration should be given to the use of other appropriate methods to protect cables, plant and equipment from fire damage, as detailed in Engineering Instruction EI 02-0031 Protecting 11kV Cables and Joints installed in air from Fire and Mechanical Damage.

For existing in air installation all joints should be protected with suitable flame retardant materials, as detailed in EI 02-0031 Protecting 11kV Cables and Joints installed in air from Fire and Mechanical Damage.

6 Cable Installation Depths

All cables shall be installed to the following minimum depths of cover, where the depth is measured to the top surface of either the cable or the duct containing the cable.

In instances where these minimum depths cannot be achieved, the cables shall be installed with additional mechanical protection, in the form of either 'stokboards', steel plates or ducts.

In this case, all steel plates shall be a minimum of 200mm wide and steel pipes shall be of the same internal diameter as the plastic ducts, normally used for the type of cable to be installed.

All steel plates and ducts shall be covered with EDF Energy Tile Tape to clearly identify that cables have been installed below.

6.1 Low Voltage Service and Mains Cables

All Low Voltage (LV) cables shall be installed to the following minimum depths, whether they are laid direct or installed in suitable ducts:

- Footways, grass verges or private property = 450mm;
- Carriageways (including road crossings) = 600mm;
- Normal agricultural land (not subject to deep ploughing) = 1050mm;
- Agricultural land subject to deep ploughing = 1200mm.

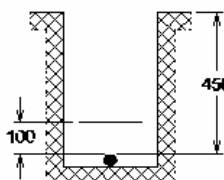
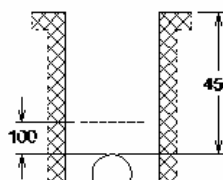
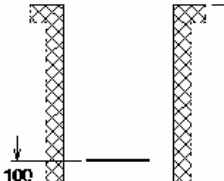
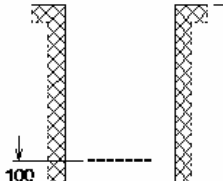
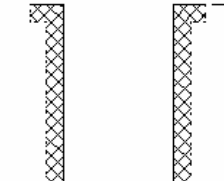
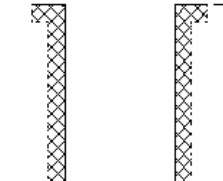
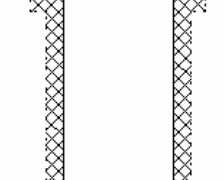
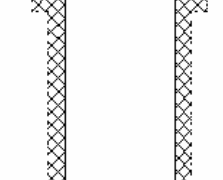
EDFENERGY	Networks Branch	Equipment Specification										
	<p style="text-align: center;">Laid Direct</p> 	<p style="text-align: center;">Ducted</p> 										
<p style="text-align: center;">Footway</p>												
<p style="text-align: center;">Carriageway</p>												
<p style="text-align: center;">Normal Arable Land</p>												
<p style="text-align: center;">Arable Land Subject to deep ploughing</p>	<p>Tile tape ——— Tile tape (Optional) - - - - -</p>											
<p>ARRANGEMENT OF LV SERVICE AND MAINS CABLE IN TRENCH</p>		<p style="text-align: center;">© EDF Energy 2005</p> <table border="1"> <tr> <td>JRN</td> <td>R.D.-1 23.05.05</td> <td>SPECIFICATION DRAWING NUMBER</td> <td>ISSUE</td> </tr> <tr> <td>CRD.</td> <td>XXX 02.03.00</td> <td rowspan="2">ES 10-0190-1</td> <td rowspan="2">1</td> </tr> <tr> <td>APP.</td> <td>XXX 02.00.06</td> </tr> </table>	JRN	R.D.-1 23.05.05	SPECIFICATION DRAWING NUMBER	ISSUE	CRD.	XXX 02.03.00	ES 10-0190-1	1	APP.	XXX 02.00.06
JRN	R.D.-1 23.05.05	SPECIFICATION DRAWING NUMBER	ISSUE									
CRD.	XXX 02.03.00	ES 10-0190-1	1									
APP.	XXX 02.00.06											

6.2 11 and 20kV Cables

All 11 and 20kV cables shall be installed to the following minimum depths, whether they are laid direct or installed in suitable ducts:

- Footways, grass verges or private property = 600mm;
- Carriageways (including road crossings) = 750mm;
- Normal agricultural land (not subject to deep ploughing) = 1050mm;
- Agricultural land subject to deep ploughing = 1200mm.

EDF ENERGY	Networks Branch	Equipment Specification																
	Laid Direct	Ducted																
Footway																		
Carriageway																		
Normal Arable Land																		
Arable Land Subject to deep ploughing																		
Tile tape ——— Tile tape (Optional) - - - - -																		
ARRANGEMENT OF 11 & 20/22kV CABLE IN TRENCH		<table border="1"> <tr> <td colspan="4" style="text-align: center;">© EDF Energy 2005</td> </tr> <tr> <td>DRN.</td> <td>R.D.H. 23.05.05</td> <td>SPECIFICATION</td> <td>ISSUE</td> </tr> <tr> <td>CKD.</td> <td>XXX 00.00.00</td> <td>DRAWING NUMBER</td> <td></td> </tr> <tr> <td>APP.</td> <td>XXX 00.00.00</td> <td>ES 10-0190-2</td> <td>1</td> </tr> </table>	© EDF Energy 2005				DRN.	R.D.H. 23.05.05	SPECIFICATION	ISSUE	CKD.	XXX 00.00.00	DRAWING NUMBER		APP.	XXX 00.00.00	ES 10-0190-2	1
© EDF Energy 2005																		
DRN.	R.D.H. 23.05.05	SPECIFICATION	ISSUE															
CKD.	XXX 00.00.00	DRAWING NUMBER																
APP.	XXX 00.00.00	ES 10-0190-2	1															

6.3 33kV Cables

All 33kV cables shall be installed to the following minimum depths, whether they are laid direct or installed in suitable ducts:

- Footways, grass verges or private property = 900mm;
- Carriageways (including road crossings) = 900mm;
- Normal agricultural land (not subject to deep ploughing) = 1050mm;
- Agricultural land subject to deep ploughing = 1200mm.

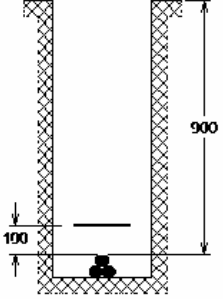
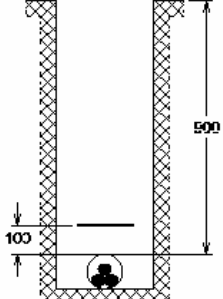
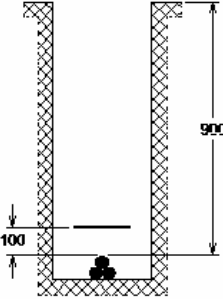
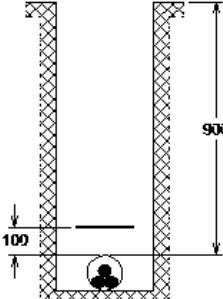
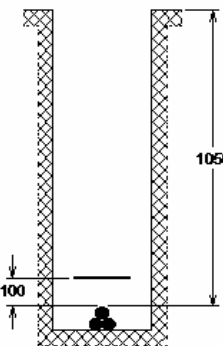
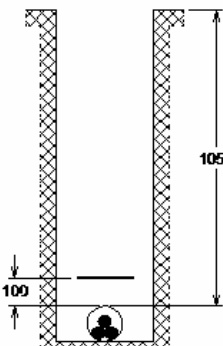
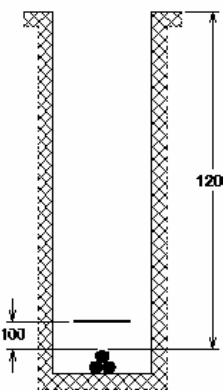
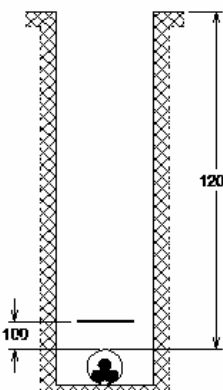
EDF ENERGY	Networks Branch	Equipment Specification										
	Laid Direct	Ducted										
Footway												
Carriageway												
Normal Arable Land												
Arable Land Subject to deep ploughing												
Skidboard ———												
<p>ARRANGEMENT OF 33kV CABLE IN TRENCH</p>		<p style="text-align: center;">© EDF Energy 2005</p> <table border="1" style="width: 100%; border-collapse: collapse;"> <tr> <td style="width: 25%;">DRN</td> <td style="width: 25%;">R.D.H. 24.05.05</td> <td style="width: 25%;">SPECIFICATION DRAWING NUMBER</td> <td style="width: 25%;">ISSUE</td> </tr> <tr> <td>CRD.</td> <td>XXX.00.00.00</td> <td rowspan="2" style="text-align: center; vertical-align: middle;">ES 10-0190-3</td> <td rowspan="2" style="text-align: center; vertical-align: middle;">1</td> </tr> <tr> <td>APP</td> <td>XXX.00.00.00</td> </tr> </table>	DRN	R.D.H. 24.05.05	SPECIFICATION DRAWING NUMBER	ISSUE	CRD.	XXX.00.00.00	ES 10-0190-3	1	APP	XXX.00.00.00
DRN	R.D.H. 24.05.05	SPECIFICATION DRAWING NUMBER	ISSUE									
CRD.	XXX.00.00.00	ES 10-0190-3	1									
APP	XXX.00.00.00											

6.4 66 and 132kV Cables

All 66 and 132kV cables shall be installed to the following minimum depths, whether they are laid direct or installed in suitable ducts:

- Footways, grass verges or private property = 900mm;
- Carriageways (including road crossings) = 900mm;
- Normal agricultural land (not subject to deep ploughing) = 1050mm;
- Agricultural land subject to deep ploughing = 1200mm.

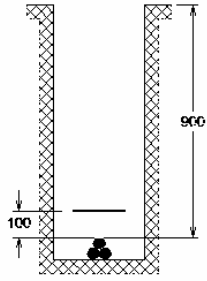
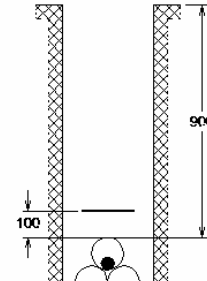
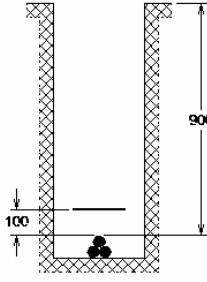
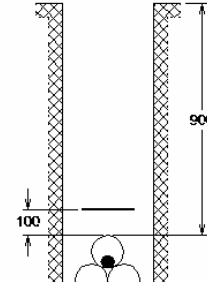
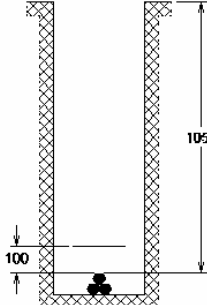
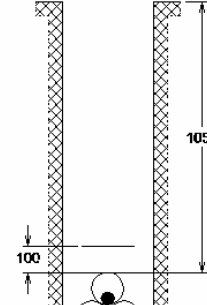
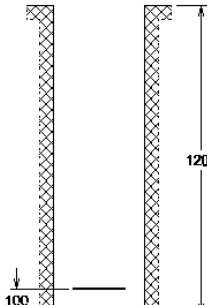
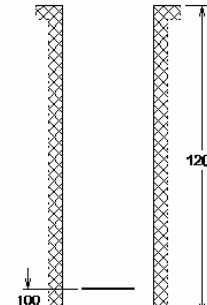
EDFENERGY	Networks Branch	Equipment Specification
	Laid Direct	Ducted
Footway		
Carriageway		
Normal Arable Land		
Arable Land Subject to deep ploughing		
Stokboard ———		

**ARRANGEMENT OF
66 & 132kV CABLE IN TRENCH**

© EDF Energy 2005			
DRN.	R.D.H. 24.05.05	SPECIFICATION DRAWING NUMBER	ISSUE
CKD.	XXX 00.00.00		
APP.	XXX 00.00.00	ES 10-0190-4	1

DB/SD10/74Z7 25.05.05

6.5 Auxiliary Multi-core and Multi-pair Cables

Auxiliary multi-core and multi-pair cables are usually laid at similar depths to the power cable with which they are associated, the following minimum depths and conditions shall apply, whether they are laid direct or installed in suitable ducts:

- All normal methods of protecting the cables from damage (i.e., Tiletape and/or "Stokboard");
- Footways, grass verges or private property = 450mm;
- Carriageways (including road crossings) = 600mm;
- Normal agricultural land (not subject to deep ploughing) = 1050mm;
- Agricultural land subject to deep ploughing = 1200mm.

6.6 Typical Trench Layouts

When Cables of differing voltages are to be installed in a common trench all the minimum of depths of cover detailed in section 6 of this engineering instruction shall be maintained.

Drawings DB/SD10/74/21 to DB/SD10/74/25 show a number of example installation for guidance.

For clarity ducted installations are not shown, cables installed in ducts shall be installed to the same standard except that the measurement for the minimum depth of cover is from the final finished surface of the ground to the top surface of the duct.

Pilot and telephone cables installed alongside 11 and 33kV cable circuits shall normally be installed at LV cable minimum depths of cover, unless operation reasons dictate that they are laid at the same depth as the power cable.

EDFENERGY

Networks Branch

Equipment Specification

Combined LV and 11 or 20kV Cables

In Footpaths etc.

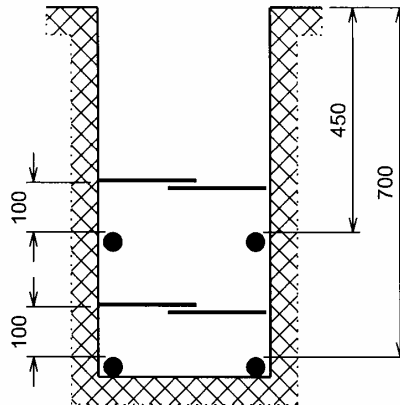
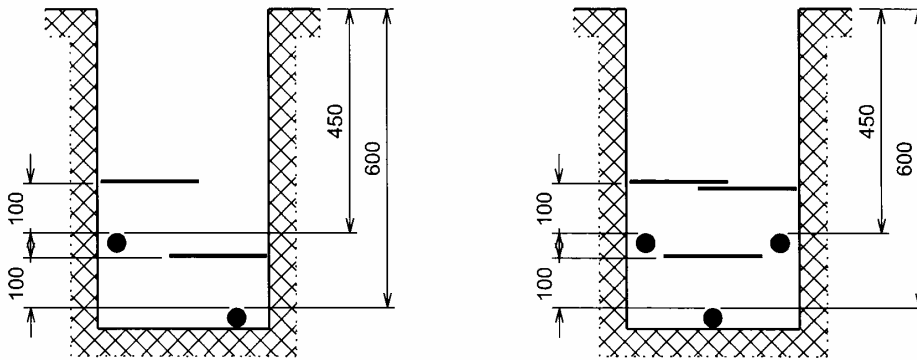

Tape Tiles 

ARRANGEMENT OF COMBINED
L.V. AND 11 OR 20kV CABLES IN TRENCH

© EDF Energy 2004

DRN.	RDH 11.04.95	DRAWING NUMBER	ISSUE
CKD.	P.W. 15.12.04	DB/SD10/74/22	2
APP.	P.W. 15.12.04		

EDFENERGY

Networks Branch

Equipment Specification

33kV and 11 or 20kV Cable

Laid Direct in Footpath etc.

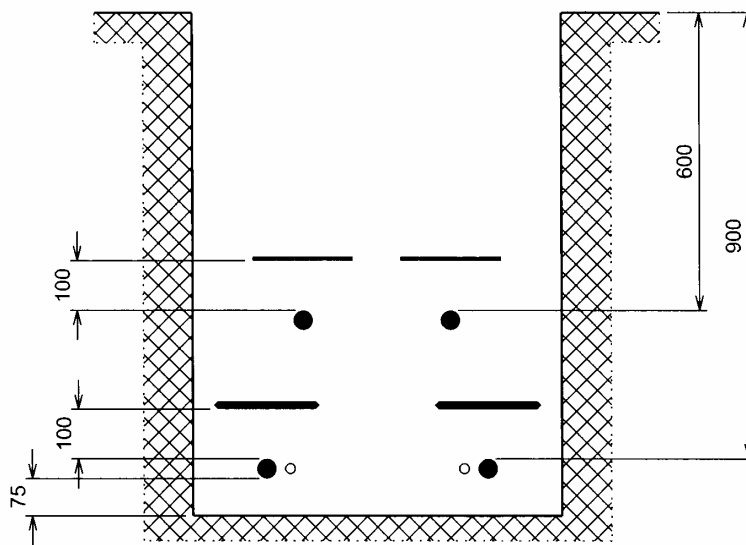

Tape Tiles

Ston Boards

ARRANGEMENT OF
33kV AND 11 OR 20kV CABLE IN TRENCH

© EDF Energy 2004			
DRN.	RDH 28.02.95	DRAWING NUMBER	ISSUE
CKD.	P.W. 15.12.04	DB/SD10/74/21	2
APP.	P.W. 15.12.04		

15.12.04

33kV Cables

Road or Footpath

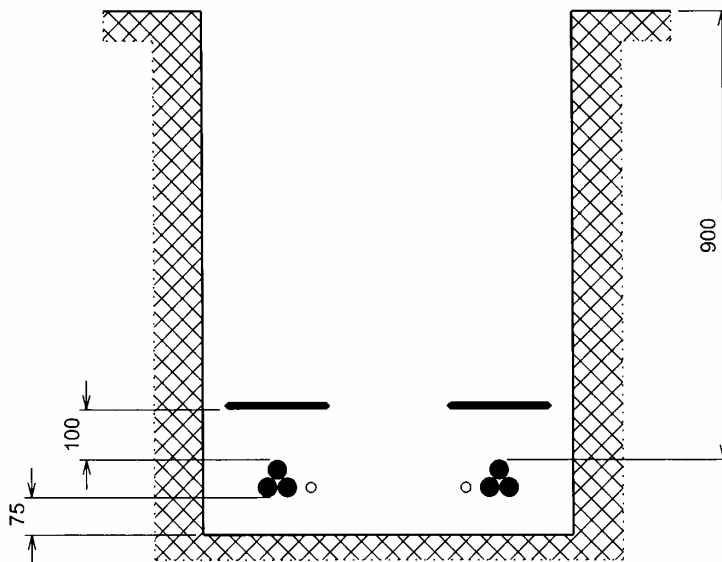
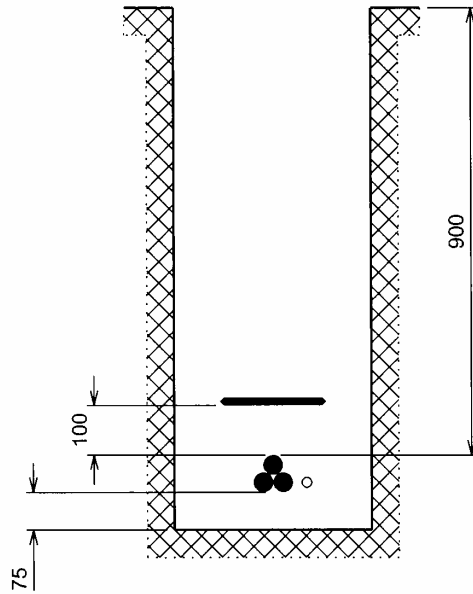

Laid direct. No extra depth for ducts.

If bedding is not required reduce depth by 75mm.

Stok Boards

ARRANGEMENT OF 33kV CABLES
IN ROAD OR FOOTPATH

© EDF Energy 2004			
DRN.	RDH 11.04.95	DRAWING NUMBER	ISSUE
CKD.	P.W. 18.05.04	DB/SD10/74/23	3
APP.	P.W. 18.05.04		

All Cables, 33kV and below Laid in Agricultural Land

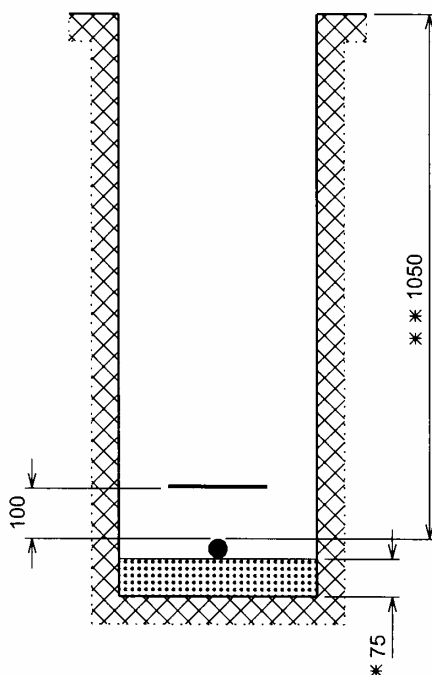

* 75mm sand bed (For 33kV cables only).

** Depth of cover increased to 1200mm if agricultural land is subject to deep plowing.

Tape Tiles

ARRANGEMENT OF CABLES IN TRENCH IN AGRICULTURAL LAND	© EDF Energy 2004		
	DRN. RDH 28.02.95	DRAWING NUMBER	ISSUE
	CKD. P.W. 18.05.04	DB/SD10/74/25	2
APP. P.W. 18.05.04			

7 Cable Installation

7.1 Trench Bedding

All cables shall only be laid directly onto the bottom of the trench, if the surface is unlikely to cause damage to the outer sheath.

Where a sand bedding material needs to be used for the base of a trench, the depth of the trench shall be increased by the appropriate amount to ensure that the required minimum depth of cover is achieved.

For 33, 66 and 132kV cable installations a selected sand bed, to a compacted depth of 75mm, shall be installed, covering the full width of the trench. The trench depth shall be increased to ensure that the required minimum depth of cover is maintained.

7.2 Cable Ducts

Electricity, pilot and telephone cables shall only be installed into electricity cable ducts, complying with EDF Energy equipment specification ES 02-0526.

New cable ducts shall be black in colour and marked with the legend 'Electric Cable Duct' on two diametrically opposite sides.

Cable shall only be installed in ducts that are suitable sized to accommodate them, Appendix A details the minimum internal duct diameters allowable for the most common types of cable used by EDF Energy.

All cable duct joints shall be installed in accordance with the manufacturers' instructions or recommendations and should be installed in such a way to prevent those damaging cables as they are installed.

All cable ducts and tubes entering substations or buildings shall be sealed with the appropriate Tyco Electronics 'Rayflate' duct seal to prevent the ingress of gas and water, even if the ducts do not contain a cable.

Where reasonably practicable, before a cable is installed, all duct lines shall be checked and cleared of all obstructions. To ensure that the duct is suitable for the type of cable to be installed, a 3 metre length of the cable to be installed shall be pulled through the complete length of duct. This shall then be examined for damage, before any attempt is made to install the complete cable. If the sample of cable is found to have deep scores and tears in its outer sheath, which are more than half the thickness of the outer sheath, the duct route shall be repaired before any attempt is made to install the final length of cable.

EDF Energy may request for a specific job that ducts containing 33kV cables shall be filled with a thermally stable re-enterable material. When such a material is used, the duct shall be installed in a concrete surround and the joints in the pipe or duct shall be effectively sealed to prevent the migration of the material and preserve its moisture content under service conditions.

7.3 Cable Drums

Where reasonably practicable, before installing a cable, the delivered cable required for the job shall be inspected to ensure that it is undamaged, the ends are sealed, and the correct

size, length and voltage type required for the job has been delivered. Any damage or non-conformity shall be rectified immediately.

All cable drums shall be placed on firm and stable surface before the cable is removed. On installation the cable shall always be pulled from the top of the drum to avoid damage.

Where it is necessary to move the drum into position the drum shall only be steered by the use of purpose made slewing bars.

All cable jacks and spindles shall be checked to ensure that they are in good condition and of the appropriate size for the weight of the drum and cable to be installed.

To avoid any risk of injury all nails shall be removed and made safe only once the drum is in its final position.

All unused cable and other unused EDF Energy materials shall be stored safely and securely on site and returned to the issuing depot as soon as is practical after the project or project phase is complete. Cable drums shall be returned to the cable manufacturer, using the free phone number displayed on the drum.

All non returnable cable drums shall be disposed of in accordance with the Environmental Protection Act.

7.4 Pulling Cable

All cables shall be handled with care and installed as indicated in the manufacturer's or EDF Energy's documentation. The cable shall be examined and checked for damage during and immediately following installation. Any damage that occurs, no matter how small, shall be reported immediately so the necessary repairs can be made.

Minimum cable bending radii shall be observed at all times and be as specified in Appendix A. Sufficient labour and equipment to install the cable without causing damage to it or other services shall be used at all times.

Cable shall only be laid when the ambient air temperature is above 0°C and has been so for the previous 24 hours, or the cable has been stored in an environment where the temperature has been maintained above 0°C, thus avoiding the risk of mechanical damage during handling.

Where a winch is to be used it shall have a swivel eye fitted. The swivel eye must be in good working order and able to freely rotate to prevent the cable twisting. The bond wire must be pulled in from the far end and tensioned to ensure it does not damage other apparatus crossing the trench.

Only serviceable winches shall be used to pull cable with an accurate dynamometer or an adjustable tension limiting switch fitted. The maximum pulling force must not exceed the values shown in Appendix A.

All pilot and telephone, LV, 11, 20, 33, 66 and 132kV cables shall normally be pulled in using a correctly sized cable stocking which is securely fixed to the cable. More difficult pulls may require the use of a pulling eye attached directly to the cable conductors.

Rollers shall always be used when pulling cables. All rollers used shall be in serviceable condition moving easily on their spindle and with rolling surfaces free from damage.

A leading roller shall be placed at the trench side at the pulling end, with slide rollers on bends and hoop rollers along straight sections. Inverted skid plates shall be used to prevent the cable or pull wire rising into obstructions. At duct entries a bell mouth shall be attached at each end with rollers positioned to give central access into the bell mouth.

Immediately following installation of cables and/or their testing, the ends of each cable shall be sealed against the ingress of moisture. Where more than one cable is being installed, both ends of each cable shall be clearly identified by the use of numbered tapes or a similar product.

7.5 Blinding Cables

Sand filled bags shall be used to support cables, joints or ancillary equipment when necessary.

All accumulated water shall be pumped from the excavation before blinding the cable or duct.

Following installation, all cables shall be blinded to a compacted depth of 100mm above the cable or cable joint with soil taken from the excavated material or imported material. The blinding shall be free from materials that may damage the cable.

Imported material for blinding (sand) shall only be used for cables 20kV or below if all the excavated material is unsuitable.

All 33, 66 and 132kV cables shall be blinded either selected sand or cement bound sand to a compacted depth of 100mm above the cable.

All blinding material over and around the cable and joint in joint bays shall be compacted by hand.

7.6 Cable Protection Covers

Marker tile tape or Stokboards shall be installed over the cables as shown in the appropriate trench drawings detailed in section 6 of this document. There is no requirement to install either to approved ducts laid by hand or trenchless techniques, but may be installed if it is deemed that additional protection is required.

All cables operating below 20kV laid direct both on public and private property shall be marked and protected by a tile tape. This also includes all single-phase service cables with a conductor size of 35mm² or less, as well as pilot and telephone cables.

The tile tape shall be cut cleanly and installed so that it is overlaid at bends to provide continuous cover to the cable route.

Only Stokboards shall be installed to protect 33, 66 and 132kV cables.

8 Trenchless Installation

8.1 General

All excavation and reinstatement work involved with trenchless methods shall be carried out in accordance with this Engineering Instruction.

When the ground conditions are suitable, cables and ducts (up to 150mm internal diameter) can be installed using trenchless installation techniques.

The entire cable or duct length shall be installed at a depth not less than the standard depth appropriate to the cable operating voltage (section 6). Where, due to uplift forces, it is necessary to install a cable or duct deeper than the standard depth, a cable or duct may be installed at depth up to 10 times the outside diameter of the cable/duct.

All ducts and couplings shall comply with EDF Energy equipment specification ES 02-0526.

Duct lengths shall only be connected by either butt fuse or electro fuse welding. The method used shall not reduce the internal diameter by more than 5mm.

A record of the route of the bored hole to indicate its position and depth shall be kept. The marking of the route shall be carried out using only bio-degradable spray paint.

Appendix A – Cable Maximum Pulling Tensions

A.1 Maximum cable pulling tensions, minimum duct dimensions and minimum bending radii for LV and 11KV Cables

Cable Size (mm ²) & Type		Maximum Pulling Tension Newtons (kgf)	Minimum Duct Internal Diameter (mm)	Minimum Bending Radius (mm)
LV Mains & Service Cables				
4	1ph copper XLPE/PVC concentric	manual	32	75
16	1ph Aluminium XLPE/PVC concentric	manual	32	100
35	1ph Aluminium XLPE/PVC concentric	manual	32	125
35	3ph Aluminium XLPE/PVC concentric	manual	41	210
95	3ph Waveform	3000 (306)	100	550
185	3ph Waveform	7000 (714)	100	700
300	3ph Waveform	7000 (714)	100	850
600	Single core aluminium PVC/PVC	manual	125	350
740	Single core aluminium PVC/PVC	manual	125	400
11kV Mains Cables				
95	Triplex Aluminium XLPE	8380 (855)	100	500
185	Triplex Aluminium XLPE	16300 (1665)	110	580
300	Triplex Aluminium XLPE	26475 (2700)	125	660
300	Triplex Copper XLPE	14700 (1500)	125	680

A.2 Maximum Cable Pulling Tensions and Minimum Bending Radii for 20kV Cables

Cable Size (mm ²) & Type		Maximum Pulling Tension Newtons (kgf)	Minimum Duct Internal Diameter (mm)	Minimum Bending Radius (mm)
20kV Mains Cables				
300	Triplex Copper XLPE	14700 (1500)	150	1250
400	Triplex Copper XLPE	19600 (2000)	150	1350

A.3 Maximum Cable Pulling Tensions and Minimum Bending Radii for 33kV Cables

Cable Size (mm ²) & Type		Maximum Pulling Tension Newtons (kgf)	Minimum Duct Internal Diameter (mm)	Minimum Bending Radius (mm)
33kV Mains Cables				
185*	Single core Copper XLPE	9070 (925)	150	850
300*	Single core Copper XLPE	14700 (1500)	150	950
400*	Single core Copper XLPE	19600 (2000)	150	1050
500*	Single core Copper XLPE	19600 (2000)	150	1100
630*	Single core Copper XLPE	19600 (2000)	150	1200
800*	Single core Copper XLPE	19600 (2000)	150	1300

* In situations where three single core cables are pulled into a single duct using a single winch the above maximum pulling tensions still apply.

A.4 Maximum Cable Pulling Tensions and Minimum Bending Radii for Multi-core and Multi-pair Cables

Cable Size (mm ²) & Type		Maximum Pulling Tension Newtons (kgf)	Minimum Duct Internal Diameter (mm)	Minimum Bending Radius (mm)
Multi-core and Multi-Pair Cables				
4 pair - 0.8mm Multi-pair		2040 (208)	85	165
7 pair - 0.8mm Multi-pair		2620 (267)	85	185
19 pair - 0.8mm Multi-pair		5210 (531)	85	260
37 pair - 0.8mm Multi-pair		8940 (911)	85	340
61 pair - 0.8mm Multi-pair		13620 (1388)	85	420
4 core - 2.5mm Multi-core		1125 (114)	85	120
7 core - 2.5mm Multi-core		1462 (149)	85	140
12 core - 2.5mm Multi-core		2508 (255)	85	180
19 core - 2.5mm Multi-core		3530 (359)	85	215
27 core - 2.5mm Multi-core		4700 (479)	85	250
37 core - 2.5mm Multi-core		5710 (582)	85	275