

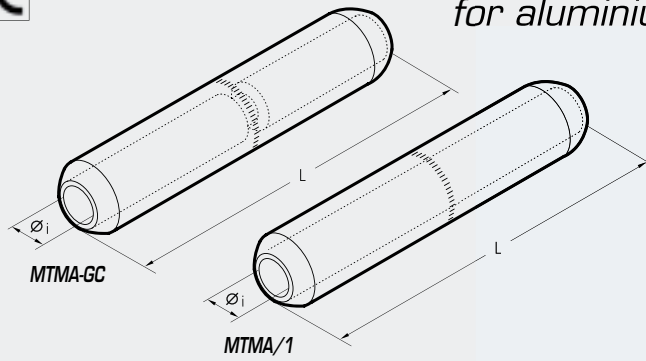

## THROUGH CONNECTORS

for aluminium conductors



# MTMA-GC MTMA/1



Conductor Size sqmm	Ref.	Ref.	Dimensions mm		Quantity Box/Bag	Hydraulic Tools
			Øi	L		
16	MTMA 16-GC	MTMA 16/1	5,5	90,5	60/3	HT 131-UC RHU 131-C B 131-UC
25	MTMA 25-GC	MTMA 25/1	6,5	90,5	60/3	
35	MTMA 35-GC	MTMA 35/1	8,0	90,5	60/3	
50	MTMA 50-GC	MTMA 50/1	9,0	106,5	30/3	
70	MTMA 70-GC	MTMA 70/1	11,0	106,5	30/3	
95	MTMA 95-GC		12,5	110,0	30/3	
		MTMA 95/1	12,5	106,5	30/3	
120	MTMA 120-GC	MTMA 120/1	13,7	133,0	30/3	
150	MTMA 150-GC		15,5	135,0	30/3	
		MTMA 150/1	15,5	133,5	30/3	
185	MTMA 185-GC	MTMA 185/1	17,0	143,5	15/3	
240	MTMA 240-GC	MTMA 240/1	19,5	143,5	15/3	
300	MTMAD 300-GC		22,5	144,5	15/3	
		MTMAD 300/1	22,5	135,0	50	

MTMA-GC series through connectors are made from aluminium of a purity equal to or greater than 99,5%. They feature a solid stop which creates a barrier between the two sides of conductors to be joined. Barrels are capped and filled with grease so as to avoid oxidation of the connector.

MTMA/1 series through connectors are unblocked and are suitable for joining cables of the same type.

## REDUCER THROUGH CONNECTORS

for aluminium conductors

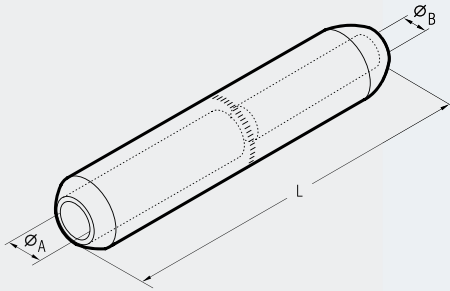

# MTMA-GC



Conductor Size sqmm	Side A Al	Side B Al/Cu	Ref.	Dimensions mm			Quantity Box/Bag	Hydraulic Tools
				ØA	ØB	L		
50	25		MTMA 50-25-GC	9,0	6,5	106,5	30/3	HT 131-UC RHU 131-C B 131-UC
	35		MTMA 50-35-GC	9,0	8,0	106,5	30/3	
70	35		MTMA 70-35-GC	11,0	8,0	106,5	30/3	
	50		MTMA 70-50-GC	11,0	9,0	106,5	30/3	
95	50		MTMA 95-50-GC	12,5	9,0	109,4	30/3	
	70		MTMA 95-70-GC	12,5	11,0	106,5	30/3	
120	70		MTMA 120-70-GC	13,7	11,0	133,0	30/3	
	95		MTMA 120-95-GC	13,7	12,5	133,0	30/3	
150	70		MTMA 150-70-GC	15,5	11,0	133,0	30/3	
	95		MTMA 150-95-GC	15,5	12,5	134,4	30/3	
185	120		MTMA 150-120-GC	15,5	13,7	133,0	30/3	
	120		MTMA 185-120-GC	17,0	13,7	143,5	15/3	
240	150		MTMA 185-150-GC	17,0	15,5	143,5	15/3	
	150		MTMA 240-150-GC	19,5	15,5	145,6	15/3	
300	185		MTMA 240-185-GC	19,5	17,0	143,5	15/3	
	185		MTMAD 300-185-GC	22,5	17,0	144,5	15/3	
	240		MTMAD 300-240-GC	22,5	19,5	144,5	15/3	

Reducer connectors are manufactured to the same construction as series MTMA-GC.

If used to join an aluminium conductor to a copper conductor care should be taken to ensure that the joint is sealed against outside elements which would cause oxidation.