



The World of Electrical safety

CATU™





First and largest european specialist in Electrical safety equipment

CATU was created in 1919 and, since the beginning, it has dedicated its activity to the manufacture of material and equipment for electricity networks and installations.

Since 1936, CATU's activity has been concentrated on equipment for personal protection against electrical hazards and accordingly, has now 70 years experience in this field.

After the end of World War II, many French companies involved in Production, Transmission and Distribution of Electrical Energy were amalgamated into one National Company, called "Electricité de France" (EDF).

A short time later, a central department for Safety and Prevention of Accidents was created within EDF. Because of the experience that CATU already had in this field, a very close cooperation was forged between EDF and CATU which resulted in joint development and improvement of all the important Safety Material and Equipment now used in France.

The international recognition gained by EDF in this field has contributed to giving CATU a foremost position at the World Wide level.

At the present time, CATU Safety Equipment, including all the range of short-circuiting and earthing systems, the DETEX™ voltage detectors and testers, the live working tools and the individual equipment for linesmen, is used by the Main Power Utilities, Electrical Contractors, Large Industries and Railways in about 100 countries spread over the 5 continents.

CATU's experience and level of investment and research is unmatched. As a member of the main national and international technical committees (such as UTE, CENELEC, IEC and ASTM), CATU is contributing to the development and application of the latest technologies. This quest for continuous improvement is now reinforced with the ISO 9001 Quality Insurance Certification.

Our endeavours to be the Specialist in Electrical Safety Equipment are made with genuine dedication to all aspects of Safety Engineering Principles. Together with our network of distributors, we acknowledge our commitment and obligations to our customers.

CATU is a Group Sicame Company

www.catuelec.com



AFAQ N°1995/4795 b



N°: 1-0897



General Products index	4	IEC Standard	9
General References index	6	Golden rules	10

Low voltage

Below 1000 V

Equipment guide	14	Installation testers	28
Personal protective equipment	18	- insulation tester	28
- head and eyes protection	18	- installation testers identifier	29
- insulating rubber gloves	20	- multimeter clamp-meter	31
- insulating mats and boots	21	Short-circuiting and earthing systems	32
Safety padlocks and warning signs	22	- for bare overhead lines	32
- padlocks	22	- for insulated overhead lines	33
- warning signs and delineators	23	- for consumer units	34
- self adhesive warning signs	24	- ISOSTOP™ system	34
Voltage detectors and testers	25	- jumper systems	34
- 6 to 690 V detectors and testers	25	- mini jumper clamps	36
- voltage detectors accessories	27	Bimaterial insulated tools	38
		Insulated tools	41

Medium voltage

From 1kV to 52 kV

Equipment guide	54	Voltage detectors	79
Personal protective equipment	58	- IEC electronic voltage detectors	79
- head and eyes protection	58	- standard electronic voltage detectors	80
- insulating rubber gloves	60	- insulating sticks	81
- insulating mats and platforms	61	- phase comparators	82
- arc flash equipment	62	Short-circuiting and earthing systems	84
- equipment for working on pole	63	- cables	84
- padlocks	67	- IEC overhead lines systems (work from pole)	85
Substation equipment	68	- clamps and accessories	86
- warning signs and delineators	68	- over head line system (work from ground)	87
- safety equipment	71	- insulating sticks	88
- IEC short-circuiting and earthing systems	72	- disconnect and measuring sticks	89
- clamps and earth clamps	73	- underground systems	90
- insulating sticks	74	General tools	91
- special short-circuiting and earthing systems (for 200 and 400 A separable connectors)	75	- sticks accessories	91
- voltage detectors and indicators	76	- tensioning equipment	93
- life saving kits	78	- handling and uncoiling blocks	95
		Earth rods	96
		- earth rods and connectors	96
		- earthing clip and earth tester	97

High voltage

Above 52 kV

Equipment guide	100	Voltage detectors	113
Personal protective equipment	102	- electronic voltage detectors	113
- head and eyes protection	102	- insulating sticks	114
- insulating rubber gloves	104	Short-circuiting and earthing systems	115
- insulating mats and boots	105	- HV and EHV clamps	115
- equipment for working on pole	106	- insulating sticks	116
Safety padlocks and warning signs	110	- earth clamps	116
- padlocks	110	- fixed points and cables	117
- warning signs	111	- accessories	118
- delineators	112		

A

Adhesive tape (safety)23
Adaptors for insulating sticks91
Adjustable spanner (insulated tools)46
Anti-fall grip63/106
Anti-fall device65/108
Arc flash equipment62

B

Bags	
- For tools50
- Carrying for rubber gloves20/60/104
- For earthing systems118
- For insulated sticks89
- For insulating mats21/61
Bent snipe nose pliers (insulated tools)39/42
Bimaterial insulated tool set40
Blocks	
- Opening95
- Uncoiling95
Boots, insulating21/61
Boundary post23/70/112
Brushes	
- For conductors92
- Cleaning92

C

Cable cutters (insulated tools)39/43/44
Cable launcher projector118
Cables	
- Copper for earthing systems84/117
- Aluminium for earthing systems84/117
Chain delineator23/70/112
Clamps, short-circuiting systems	
- Medium Voltage	
. For installations and substations73
. Automatic85
- High voltage	
. Manoeuvrable by insulating sticks115
. Rope operated118
Clamp dispenser heads86
Climbers	
- For wooden poles66
- For rectangular shaped concrete poles66
- For round and hexagonal concrete poles66
- For H profile pole66
Come-along	
- Automatic clamp93
- Adjustment93
- Parallel jaws94
Combination wrench (insulated tools)46
Comparator, sound phase77
Comparators, Two poles phase82/83
Comparator single pole83
Connector with stick adapter65
Connectors for earth rods96
Constraint tie65/108
Covers for insulating sticks88
Cranked ring wrench (insulated tools)47
Crocodile clamps (safety)27

D

Delineators23/70/112
Descent device63/106
Diameter gauge92
Digital clamp meter31
Digital multimeter31

E

Earth clamps, High Voltage116
Earth clamps, Medium voltage73
Earth rod for low voltage earthing systems33
Earth rods for medium voltage earthing clip97
Earthing systems86
Earth rods96
Earthing systems	
- Low voltage	
. For overhead lines32/33
- Medium Voltage	
. For overhead lines IEC85
. For overhead lines87
. For substations IEC72
. For substations (for 250 and 400 A connectors)75
. For underground cables90
- High Voltage	
. High voltage systems115/116
Electrician's scissors45
End cutting pliers (insulated tools)43

F

Face shield18/58/102
Fall arrester64/107
Fixing tools for warning signs23
Fixed points	
- Medium Voltage73
- High Voltage117
Flags, warning70/112
Flat nose pliers (insulated tools)39/42
Frontal ratchet cable cutter44
Fuse holder for substation71
Fuse puller92

G

Glasses	
- Safety glasses18/58/102
- Safety overglasses18/58/102
Gloves	
- Insulating rubber gloves20/60/104
- Overgloves20/60/104
- Undergloves20/60/104
- Working gloves20/61/104
Gloves storage box20/60/104
Gloves tester20/60/104
Guying equipment95

H

Hacksaw (insulated tools)44
Handle for padlocks22/67/110
Harness	
- Full body fall arrest63/106
- Pro electric full body fall arrest63/106
Headlamps	
- With adjustable focus19/59/103
- With leds19/59/103
- Atex with leds19/59/103
Helmets	
- ABS18/58/102
- Polycarbonate18/58/102
Hexagonal spanner (insulated tools)47
Hooks	
- Manoeuvring92
- Pig tail92

I

Indicator phase rotation, low voltage26
Indicators	
- Permanent luminous76
- Permanent for medium voltage cubicles77
Insulated tools	
- Bimaterial insulated tools38
- Bimaterial insulated tools kits40
- Insulated tools41
- Insulated tools kits50
Insulating mats	
- Low voltage21
- Medium voltage61
- High voltage105
Insulating platforms	
- Medium Voltage61
- High Voltage105
Insulating sticks	
- Medium voltage	
. Clampsticks74/89
. Disconnect telescopic89
. Measuring telescopic89
. For substation short-circuiting systems74
. For overhead lines short circuiting systems88
. For voltage detectors81
. Rescue stick78
- High Voltage	
. For short-circuiting systems116
. For voltage detectors114
. Rescue sticks105
Intervention kit (substation equipment)71
(for electricians)51

J

Jumper cables with clamps34
Jumper cables with threaded ferrules36
Jumper cables with insulated clamps37
Jumper connecting box37

K

Kits	
- Intervention for substations	.71
- Insulated tools	.50
- For working on pole	.65/108

L

Ladders	.66/109
Lamp, safety for substations	.71
Lanyard	.64/107
Life saving kits for substations	.78
Long nose pliers (insulated tools)	.42
Lockout for single pole breaker	.22
Lockout with padlock for single pole breaker	.22
Low voltage complete set	.51

M

Markers	.22/67/110
Mats, insulating	.21/61/105
Mechanical adjusters	.94
Mini jumper clamps	.36
Multimeter	.31

O

Open end spanner (insulated tools)	.47
------------------------------------	-----

P

Padlocks, safety	.22/67/110
Platform, insulating	
- Medium Voltage	.61
- High Voltage	.105
Plug pliers (insulated tools)	.43
Probes	
- Contact probes for L.V testers	.27
- Safety test probes for voltage detectors	.27
- Safety test probes for multimeter	.31
Pruning saw	.92

R

Ratchet cable cutter (insulated tools)	.44
Ratchet lift-chain hoist	.95
Reel launcher	.118
Rescue sticks	
- Medium voltage	.78
- High voltage	.105
Right angle hexagonal key wrench (insulated tools)	.46
Rope	
- Safety	.64/107
- Straps with lever stretcher	.63/106
- With energy absorber	.63/106
Round nose pliers (insulated tools)	.39/42
Reversible hexagonal ratchet handle	.46

S

Screwdrivers (insulated tools)	.38/41
Short-Circuiting Systems	
- Low voltage	
. For bare conductors	.32
. For insulated conductors	.33
. For consumer units	.34
. Isostop system	.34
. Equipment for consumer units	.35
- Medium Voltage	
. For overhead lines IEC	.85
. For substations IEC	.72
. For substations (for 250 and 400 A connectors)	.75
. For underground cables	.90
- High Voltage	
. High voltage systems	.115/116
Shunt telescopic probe	.37
Side cutters (insulated tools)	.39/43
Snap hooks	.64/107
Sockets 3/8" long series (insulated tools)	.49
Sockets 3/8" U.S standard (insulated tools)	.49
Sockets 6 sided Male (insulated tools)	.49
Sockets wrench set (insulated tools)	.48/49
Stepladders, insulating	.21
Stick case	.114
Sticks, Insulating	
- Medium voltage	
. Clampsticks	.74/89
. Disconnect telescopic	.89
. Measuring telescopic	.89
. For substation short-circuiting systems	.74
. For overhead lines short circuiting systems	.88
. For voltage detectors	.81
High Voltage	
. For short circuiting systems	.116
. For voltage detectors	.114
Stripping pliers (insulated tools)	.45
Stripping knives (insulated tools)	.45
Switching devices identifier (L.V.)	.29

T

Tap off box	.37
Testers, Low Voltage	
- For electrical installations	.29
- For voltage	.25/26
- Earth tester	.30/97
- For insulation	.28
Threaded adapter	.37
Testing device for phase comparator	.82
Tether rope	.64/107
Torch safe light	.71
Torque wrench 3/8", insulated	.49
Trimmer	.92

U

Universal pliers (insulated tools)	.39/42
------------------------------------	--------

V

Voltage detector for permanent indicators	.76/77
Voltage detectors	
- Low voltage	
. Muti-tester	.25
. With phase rotation	.26
- Medium voltage	
. Indoor use	.76
. Compact serie	.76
. For separable connectors	.76
. Electronic IEC	.79
. Electronic standard	.80
- High voltage	
. Electronic	.113

W

Wall mounted supports	.74
Warning signs	
- Self adhesive	.24/68
- Low voltage	.23
- Medium voltage	.69
- High voltage	.111
Waterpump pliers (insulated tools)	.39/43
Winches	.94
Wire stripping pliers (insulated tools)	.39/45
Working on pole kits	.65/108

The characteristics and technical informations stated in our literature are only for your guidance and therefore cannot be considered as contractual. Our company is entitled to modify at any time the characteristics of its equipments. In case of modification of these characteristics, our company would not be obliged to supply materials conform to those previously in force.

"Alu-Metal, Alu-Script, Catu, Catex, Catohm, Clipblock, Detex, Detex-Lumifix, Isomil, Lowlock, Major, Normafix, Normagrif, Pelican 2, Piezo-Test, Pointest, Snaplock, Triplex" are trade marks of Catu S.A.

Non contractual photographs

References	Pages
AC-21	23
AC-44	23
AD-01	23
AL-138	23
AL-200	22/67/110
AL-201	22
AL-201/C	22
AL-202	22/67/110
AL-207/10	22/67/110
AL-207/30	22/67/110
AL-230	51
AL-230-(*)-EX	22/67/110
AL-230-S-(*)-EX	22/67/110
AL-230-S-Z-EX	22/67/110
AL-230-Z-EX	22/67/110
AL-236-111-EX	22/67/110
AL-236-222-EX	22/67/110
AL-236-S-111-EX	22/67/110
AL-236-S-222-EX	22/67/110
AL-240-(*)-EX	22/67/110
AL-240-S-(*)-EX	22/67/110
AL-240-S-Z-EX	22/67/110
AL-240-Z-EX	22/67/110
AL-31	23/70/112
AL-31/05	23/70/112
AL-31/25	23/70/112
AL-316	23/70/112
AL-318	23/70/112
AL-32/05	23/70/112
AL-53	70/112
AL-58	70/112
AL-60	70/112
AL-62-A	23/70/112
AL-63-A	23/70/112
AM-20-GB	23/69/111
AM-20-RM	69/111
AM-215-RM	69/111
AM-282/2-RM	69/111
AM-32/3	69/111
AM-33/3	69/111
AM-34/2	69/111
AM-344	23/69/111
AM-344/05	23/69/111
AM-344-GB	23/69/111
AM-345-GB	23/69/111
AM-41/1	23/69/111
AM-41/2	23/69/111
AM-467-GB	23/67/110
AM-49/1	23/69/111
AM-49/2	23/69/111
AM-61-GB	69/111
AM-61-RM	69/111
AM-7002	69/111
AP-499/1	23/70/112
AP-510-BT-GB	23
AP-510-GB	69/111
AP-951/2	69/111
AS-404	22/67/110
AT-41/025	24/68
AT-41/05	24/68
AT-41/1	24/68
AT-49/025	24/68
AT-49/05	24/68
AT-49/1	24/68
AT-50/025	24/68
AT-50/053	24/68
AT-50/1	24/68
AT-5005	23
AT-51/025	24/68
AT-51/05	24/68
AT-51/1	24/68
AT-52/05	24/68

References	Pages
AT-52/1	24/68
AT-53/05	24/68
AT-53/1	24/68
AT-54/05	24/68
AT-54/1	24/68
AT-55/05	24/68
AT-55/1	24/68
AT-56/05	24/68
AT-56/1	24/68
AT-57/05	24/68
AT-57/1	24/68
AT-58/05	24/68
AT-58/1	24/68
AT-59/05	24/68
AT-59/1	24/68
AT-60/05	24/68
AT-60/1	24/68
AT-61/05	24/68
AT-61/1	24/68
AT-62/05	24/68
AT-62/1	24/68
AT-63/05	24/68
AT-63/1	24/68
AT-66/1	24/68
C-92-20	82
C-92-492	80
CC-151-K	75/76
CC-245-150/420-K	113
CC-245-225/420...*	113
CC-245-225/550-K	113
CC-245-60/150-K	113
CC-245-63/90...*	113
CC-245-63/150-K	113
CC-245-66/132-K	113
CC-245-90/225-K	113
CC-363*	80
CC-365-101	80
CC-45-K	76
CC-875-10/36*	79
CC-875-11/33*	79
CD-103	71
CD-104	71
CD-122	71
CD-124	71
CE-4-21*	74/81
CE-5-105-(*)	89
CE-5-50-(*)	89
CE-5-60-(*)	89
CE-5-70-(*)	89
CE-5-90-(*)	89
CE-5-90-C	65
CE-75*	81
CF-3-72*	74
CF-5-40*	74/88
CF-5-90*	88
CG-02 (*)	20
CG-05 (*)	20
CG-05-B	51
CG-05-C	51
CG-10 (*)	20
CG-10 (*)-AM	20
CG-117	20/60/104
CG-12 (*)	20
CG-15 (*)	60
CG-20 (*)	60
CG-20 (*)-AM	60
CG-30 (*)	60/104
CG-30 (*)-AM	60/104
CG-35/1	20/60/104
CG-36	20/51/60/104
CG-40 (**)	104
CG-40 (**)-AM	104

References	Pages
CG-80 (**)	20/60/104
CG-96 (*)	21
CG-97-C	61/104
CG-98	51
CG-98 (*)	20
CG-99 (*)	60/104
CI-06-D	74
CI-10-D	74
CI-12-D	74
CL-1-05	82
CL-2-10/30-2	76
CL-2-5/36-2	76
CL-40010	76
CL-4-41/2	76
CL-495-3	77
CL-497-00	77
CL-498-00	77
CL-499/101	77
CL-5-03	83
CL-5-33-GB	83
CL-5-36	83
CL-7-06/18*	83
CL-7-10/30*	83
CL-7-10/30-1*	83
CL-7-12/36*	83
CL-8-05	82
CL-8-36	82
CL-8-36/1	82
CM-02*	92
CM-1-10	89
CM-1-15	89
CM-1-20	89
CM-3000	114
CM-3-03	88
CM-3-04	88
CM-3-05	88
CM-3-06	88
CM-04-K	92
CM-4115-*	114
CM-4120-*	114
CM-4125-*	114
CM-4130-*	114
CM-4220*	114
CM-4230*	114
CM-4240*	114
CM-4345*	114
CM-4360*	114
CM-4400-J	88
CM-4410	88
CM-4410-*	88
CM-4410-I	88
CM-4415	88
CM-4415-*	88
CM-4415-I	88
CM-4420	88
CM-4420-*	88
CM-4420-I	88
CM-4425	88
CM-4425-*	88
CM-4425-I	88
CM-4600-J	114
CM-4610	114
CM-4610-*	114
CM-4610-I	114
CM-4615	114
CM-4615-*	114
CM-4615-I	114
CM-4620	114
CM-4620-*	114
CM-4620-I	114
CM-4625	114
CM-4625-*	114

References	Pages
CM-4625-I	114
CM-6-15	116
CM-6-20	116
CM-6-25	116
CM-6-30	116
CM-7-10-A	81
COL-32/100	97
COL-8/32	97
CS-225*	105
CS-45	78
CS-90*	105
CT-7-25/1	61
CT-7-40/1	61
CT-7-63	105
CT-9-25	61
CT-9-45	61
CT-9-63	105
CX-01222	27
CX-01422	27
CX-01822	27
CX-35811	27
CX-45211	27
CX-45411	27
CX-45511	27
CZ-53-MR	78
CZ-53-MR/2	78
CZ-53-R	78
CZ-53-R/2	78
CZ-54-MR	78
CZ-54-R	78
CZ-55-MR	78
CZ-55-R	78
DT-102	29
DT-110	29
DT-150	29
DT-157	29
DT-300	30
DT-307	30
DT-500	28
DX-02001	31
DX-02002	31
DX-02006	27/29
KIT-01*	71
KIT-03	50
KIT-04	50
KIT-05	50
KIT-07	50
KIT-10**	71
KIT-23	40
KIT-24	40
KIT-25	40
KIT-27	40
KIT-ARC-01	62
KIT-ARC-02	62
KIT-ARC-03	62
KIT-ARC-04	62
KIT-HAUT-01-(*)	65/108
KIT-HAUT-02-(*)	65/108
KIT-HAUT-03-(*)	65/108
KIT-HAUT-04-(*)	65/108
KIT-HAUT-05-(*)	65/108
KIT-HAUT-06-(*)	65/108
M-24-10	84
M-24-120	84/117
M-24-120-S	84/117
M-24-150	84/117
M-24-150-S	84/117
M-24-16	84
M-24-16-S	84
M-24-25	84
M-24-25-S	84
M-24-30	84

General references index



References	Pages
M-24-35	84
M-24-35-S	84
M-24-40	84
M-24-50	84
M-24-50-S	84
M-24-70	84/117
M-24-70-S	84/117
M-24-75	84/117
M-24-95	84/117
M-24-95-S	84/117
M-28-120	84/117
M-28-150	84/117
M-28-50	84
M-28-70	84/117
M-87-153	118
M-87292	28/30
M-87-295	65/118
M-87369	25/26
M-87370	50/51
M-87384	18/59
M-87386	21/61
M-87-53	118
M-881622	18/58/102
M-881635	18
M-92-1172	30
M-92-28	92
M-95-1143	30
M-951735	29
M-951736	29
M-952271	29/30
M-95626/4*	35
M-95627/4*	35
M-95-864	19/59/71/103
M-95-865	19/59/103
MC-116	37
MC-120/100	37
MC-120/15	37
MC-120/50	37
MC-121	37
MC-122	37
MC-123	37
MC-124	37
MC-126	37
MC-126/1	37
MC-141	36
MC-142	35/36
MC-143	36
MC-144	36
MC-145	36
MC-146	36
MC-147	36
MC-147/1	36
MC-148	36
MC-148/1	36
MC-149	36
MC-150	37
MC-153/05	36
MC-153/10	36
MC-153/30	36
MC-153/60	36
MC-155/05	36
MC-155/10	36
MC-155/20	36
MC-155/30	36
MC-155/60	36
MC-155/80	36
MC-156	37
MC-156/1	37
MC-161	35
MC-165/40	34
MC-166/40	34
MC-166/60	34

References	Pages
MC-175/40	34
MC-181	37
MC-182	37
MC-183	37
MC-290/2	34
MC-296-00/08*	35
MC-296-115/08*	35
MC-296-115/12*	35
MC-296-160/12*	35
MC-296-320	35
MC-296-440	35
MD-02	63/106
MD-10-C	92
MD-12-C	92
MD-14-C	92
MD-40-*	92
MD-42-B	92
MD-535-K	92
MF-60	118
MF-61	118
MF-62	118
MF-63	118
MF-66	118
MG-115/1-S	74
MG-206-AK	92
MG-206-CK	92
MG-207-K	92
MG-207-S	92
MG-208-K	89
MG-352-K	92
MG-352-VK	92
MG-353-R	92
MG-353-V	92
MG-354-K	92
MG-355	92
MGS-100-S	89
MGS-103-S	89
MK-08	93
MK-100	94
MK-15	93
MK-20	93
MK-40	94
MK-60	94
ML-05/10	94
ML-08/20*	94
ML-16/20*	94
ML-32/20*	94
MO-052	64/107
MO-11000	18/58/102
MO-11001	18/51/58/102
MO-11010	18/58/102
MO-11011	18/58/102
MO-16-A	66
MO-17-A	66
MO-182/1-B	18/58/102
MO-182/1-R	18/58/102
MO-183-BL	18/58/102
MO-183-RL	18/58/102
MO-184	18/58/102
MO-185-B	18/58/102
MO-185-BL	18/58/102
MO-185-J	18/58/102
MO-185-R	18/58/102
MO-186	18
MO-23	66
MO-237-D	37
MO-24	66
MO-25	66
MO-26	66
MO-308	95
MO-331/04-B	94
MO-331/06-A	94

References	Pages
MO-331/08-B	94
MO-331/09-A	94
MO-331/10-B	94
MO-331/12-A	94
MO-331/13-P	93/94
MO-331/16-B	94
MO-331/22-P	93
MO-331/26-B	94
MO-331/38-P	93
MO-332/09-D	93
MO-332/13-E	93
MO-332/14-D	93
MO-332/18-E	93
MO-332/22-E	93
MO-337/06	93
MO-339/02	93
MO-339/03	93
MO-34	50
MO-35	66
MO-371/01	95
MO-371/100	95
MO-375/150	95
MO-375/250	95
MO-375/300	95
MO-375/400	95
MO-375/600	95
MO-375/800	95
MO-431/07	95
MO-431/15	95
MO-431/30	95
MO-435/07	95
MO-435/15	95
MO-510-03-EX	51
MO-52020	63/65/106
MO-52021	63/106
MO-52031	65/108
MO-52033	65/108
MO-52034	65/108
MO-52-L	63/106
MO-53	64/107
MO-54	64/65/107
MO-54000	64/107
MO-54002	64/107
MO-54004	64/107
MO-54005	65
MO-54010	63/65/106
MO-55/1	64/107
MO-56009	64/65/107
MO-56010	64/107
MO-563	65
MO-563(*)	63/106
MO-564	65
MO-564(*)	63/106
MO-591000	65/108
MO-591002	64/107
MO-61001	45/51
MO-61002	45
MO-64502	44
MO-65203	41
MO-65204	41/50/51
MO-65205	41/51
MO-65206	41/50/51
MO-65207	41/51
MO-65209	41/50/51
MO-65211	41
MO-65222	41
MO-65230	41
MO-65232	41/51
MO-65234	41/51
MO-65236	41/51
MO-65238	41
MO-65240	41

References	Pages
MO-65242	41/50/51
MO-65244	41/50/51
MO-65246	41
MO-65248	41
MO-66001	42
MO-66002	42/50/51
MO-66003	42
MO-66005*	42
MO-66102	42
MO-66105	43
MO-66202	42/51
MO-66300	42
MO-66302	42
MO-66402	42/50/51
MO-66404	42
MO-66502	43/50/51
MO-66505	43
MO-67101	43
MO-67102	43/51
MO-67103	43
MO-67302	45/50/51
MO-67304	45
MO-67305	45
MO-67306	45
MO-67401	43
MO-67402	43
MO-67404	43
MO-67500	43/50/51
MO-67501	44
MO-67502	44/51
MO-67599	44
MO-67600	44
MO-67601	44
MO-67611	44
MO-68/10	63/106
MO-68/15	63/65/106
MO-68008	47
MO-68008/19	47/51
MO-68009	47
MO-68010	47
MO-68011	47
MO-68012	47
MO-68013	47
MO-68014	47
MO-68015	47
MO-68016	47
MO-68017	47
MO-68018	47
MO-68019	47
MO-68020	47
MO-68021	47
MO-68022	47
MO-68023	47
MO-68024	47
MO-68025	47
MO-68026	47
MO-68027	47
MO-68028	47
MO-68029	47
MO-68030	47
MO-68032	47
MO-68107	47
MO-68108	47
MO-68109	47
MO-68110	47
MO-68111	47
MO-68112	47
MO-68113	47
MO-68114	47
MO-68115	47
MO-68116	47
MO-68117	47

References	Pages
MO-68118	47
MO-68119	47
MO-68120	47
MO-68121	47
MO-68122	47
MO-68123	47
MO-68124	47
MO-68125	47
MO-68126	47
MO-68127	47
MO-68128	47
MO-68129	47
MO-68130	47
MO-68132	47
MO-68610	47
MO-68613	47
MO-68614	47
MO-68701	46
MO-68702	46
MO-68703	46
MO-68704	46
MO-69002	46
MO-69003	46/51
MO-69004	46
MO-69005	46
MO-69050	49
MO-69210	46
MO-69213	46
MO-69216	46
MO-69217	46
MO-69218	46
MO-69219	46
MO-69306	48
MO-69307	48
MO-69308*	48
MO-69308/23	48/51
MO-69309	48
MO-69310*	48
MO-693100	49
MO-69311	48
MO-69312*	48
MO-69313*	48
MO-69314*	48
MO-69315	48
MO-69316	48
MO-69317	49
MO-69317*	48
MO-69318	48
MO-69319*	48
MO-69321*	48
MO-69322*	48
MO-69323*	48
MO-69393	49
MO-69394	49
MO-69395	49
MO-69396	49
MO-69397	49
MO-69398	49
MO-69408*	48
MO-69408/23	48
MO-69410*	48
MO-69411	48
MO-69412*	48
MO-69413*	48
MO-69414*	48
MO-69415	48
MO-69416	48
MO-69417	48
MO-69418	48
MO-69419*	48
MO-69420	48
MO-69421*	48

References	Pages
MO-69422*	48
MO-69423*	48
MO-69424	48
MO-69430	48
MO-69512	49
MO-69513*	48
MO-69514*	48
MO-69523*	48
MO-69524*	48
MO-69533	48
MO-69534	48
MO-69542	48
MO-69543	48
MO-69544	48
MO-69610	49
MO-69613	49
MO-69614	49
MO-69616	49
MO-69617	49
MO-69618	49
MO-69619	49
MO-69621	49
MO-69735	49
MO-69736	49
MO-69737	49
MO-69738	49
MO-69739	49
MO-69740	49
MO-69741	49
MO-69742	49
MO-69810	49
MO-69810/17	49
MO-69813	49
MO-69813/17	49
MO-69840	49
MO-69903	46/51
MO-69904	46/51
MO-69905	46
MO-69906	46/51
MO-69908	46
MO-69910	46
MO-69912	46
MO-71	63/65/106
MO-72003	38
MO-72004	38/40
MO-72005	38
MO-72006	38/40
MO-72007	38
MO-72009	38/40
MO-72040	38
MO-72042	38/40
MO-72044	38/40
MO-72046	38
MO-72100	45
MO-72102	39/40
MO-72122	39
MO-72132	39
MO-72142	39/40
MO-72155	39/40
MO-72162	39
MO-72172	39/40
MO-72200	39/40
MO-751	51
MO-832	89
MP-01	21/61
MP-02	21/61
MP-100/03-10	21/61
MP-100/03-5	21/61
MP-100/05-10	61
MP-100/05-5	61
MP-100/10-10	105
MP-100/10-5	105

References	Pages
MP-19	51
MP-211	90
MP-212	90
MP-26-A	51
MP-311	95
MP-315	95
MP-32/15	51
MP-35/12	51
MP-39	51
MP-42/11	21/61
MP-42/16	21/51/61
MP-42/66	21/61
MP-506/2	66/109
MP-508/2	66/109
MP-510/2	66/109
MP-514/2	66/109
MP-515/2	66/109
MP-60/03-10	21/61
MP-60/03-5	21/61
MP-60/05-10	61
MP-60/05-5	61
MP-60/10-10	105
MP-60/10-5	105
MP-700-1	21
MP-700-2	21
MP-700-3	21
MP-700-4	21
MP-700-5	21
MS-115-1	71
MS-118	19/59/103
MS-121	19/59/103
MS-126	19/59/71/103
MS-127	19/59/103
MS-152+	26
MS-62	27
MS-63	27
MS-8013	27
MS-8014	27
MS-911/2	26
MS-911-EX	25/51
MT-1910	72
MT-1911	73
MT-1911-E	73
MT-1911-S1	73
MT-1920	72
MT-1921	73
MT-1921-E	73
MT-1921-S1	73
MT-205	33
MT-206	33
MT-207	33
MT-245	33
MT-249	33
MT-2950/35*	73
MT-2951	73
MT-2951/1	73
MT-2951/2	73
MT-315/2	34
MT-3950/35*	73
MT-3951	73
MT-3951/1	73
MT-3952	73
MT-3952/1	73
MT-404	32
MT-405	32
MT-406	32
MT-407	32
MT-508/36	87
MT-508/46	87
MT-5805	72
MT-613	85
MT-613/1	85

References	Pages
MT-613/2	85
MT-615/1-7,5	32
MT-615/2-7,5	32
MT-630-C	86
MT-630-K	86
MT-630-S	86
MT-633-C	86
MT-633-K	86
MT-633-S	86
MT-634-C/K	86
MT-635/1-C/K/S	86
MT-640-S	86
MT-641-S	86
MT-650	33/86
MT-652/10	86
MT-652/15	86
MT-6613	85
MT-6613/1	85
MT-701/1	118
MT-708/40	118
MT-709-B	118
MT-731*	115
MT-732*	115
MT-734*	115
MT-735*	115
MT-737*	115
MT-790	117
MT-792	117
MT-797	117
MT-812-C	73
MT-813-C	73
MT-814/2	73
MT-814/3	73
MT-815-C	73
MT-815-E	73
MT-815-S	73
MT-815-S1	73
MT-817-C	73
MT-840/1	73/86
MT-841	73
MT-843	86/116
MT-847	116
MT-852	116
MT-853	116
MT-8612	75
MT-8614	75
MT-895	117
MT-9801	72
MV-135*	21/61
MX-300	29
MX-404	77
MX-430-M	97
MX-433-T	97
MX-701	31
MX-702	31
TO-2-16	96
TO-2-19	96
TO-3-16/19	96
TP-1610-R	96
TP-1615-R	96
TP-1620-R	96
TP-1910-R	96
TP-1915-R	96
TP-1920-R	96
TR-116-10	96
TR-116-15	96
TR-119-10	96
TR-119-15	96
TR-119-20	96
TR-1610	96
TR-1615	96
TR-1620	96
TR-1910	96
TR-1915	96
TR-1920	96
TS-1601	96
TS-1901	96

IEC Standard



International Electrotechnical Commission is a worldwide organization for standardization comprising national electrotechnical committees (NC). The object of the IEC is to promote international cooperation on all questions concerning standardization in the electrical fields. These standard have been approved by more than 50 different countries including Australia, Canada, China, France, Germany, Japan, Russia, Malaysia, Singapore, Mexico, India, Indonesia, South Africa, New Zealand, USA...

A rapid need to perform electrical operations evolved with the time. This resulted in regional or national working on specific standards without coordination.

IEC standards were developed according to a consensus procedure and approved by recognised body. They provide an adequate answer at worldwide level.

The IEC standard presents benefits to all parties involved:

- for the end-users: it is the guarantee of a suitable and internationally recognized quality equipment,
- for the Testing Laboratories: it determines better standards of testing and control procedures for materials,
- for the manufacturers: it helps them to make a better technico-commercial offer.

Designs, tests and manufactures under the IEC requirements.

Is the first manufacturer to provide a full range of products complying with the IEC standards.

Shows its innovation ability for the welfare of the electrical world.

CATU™

Golden safety rules



Electrical accidents are responsible for severe body injuries, which cause troubles not only for the workers themselves, but for their families as well.

Furthermore they cause financial penalties to the utilities, due to the failure of supply and the cost associated with the injured workers.

How does the electrical risk appears?

- When an electrical line or conductor is unexpectedly still live
- When current sources are not properly isolated
- When power generators are connected to the network
- When there are atmospheric phenomena such as lightning
- Through induced currents

However, it has also been statistically observed that the most common causes of unexpected presence of voltage on electrical lines or installations were due to:

- A mistake in operating a switch
- A mistake in identifying the work to perform
- A "faulty" switch (one of the links for example remaining partially engaged)

How to avoid electrical accidents?

1. By observing Simple Electrical Safety Rules directed by common Sense (even if Working Practices vary from a country to another, GOLDEN RULES always apply).
2. By using Simple, Light and Reliable Electrical Safety Equipment.

First, select the right equipment

Personal protective equipment, safety padlock, voltage detector, short circuiting and earthing system, warning signs.



Golden safety rules

SEPARATE THE WORK AREA FROM ALL POSSIBLE SOURCES OF POWER-SUPPLY by opening circuit-breakers, switches...

1



2

LOCK THE LINK IN THE OPEN POSITION with a safety lock system (safety padlock)

CHECK THE ABSENCE OF VOLTAGE at source and on site, on each conductor and apparatus involved.

3



4

APPLY APPROPRIATE SHORT-CIRCUIT AND EARTHING SYSTEMS in sufficient numbers on the conductors of your network where operation is taking place.

SHOWN, WARN OTHERS AND LIMIT THE WORK AREA even during the most simple temporary maintenance operation

5



Low voltage product display



Protective equipment

Warning signs

Safety padlocks

Voltage detectors

Insulated tools 1000V

The major products are now at your
electrical dealer's

Low voltage



Below 1000 V

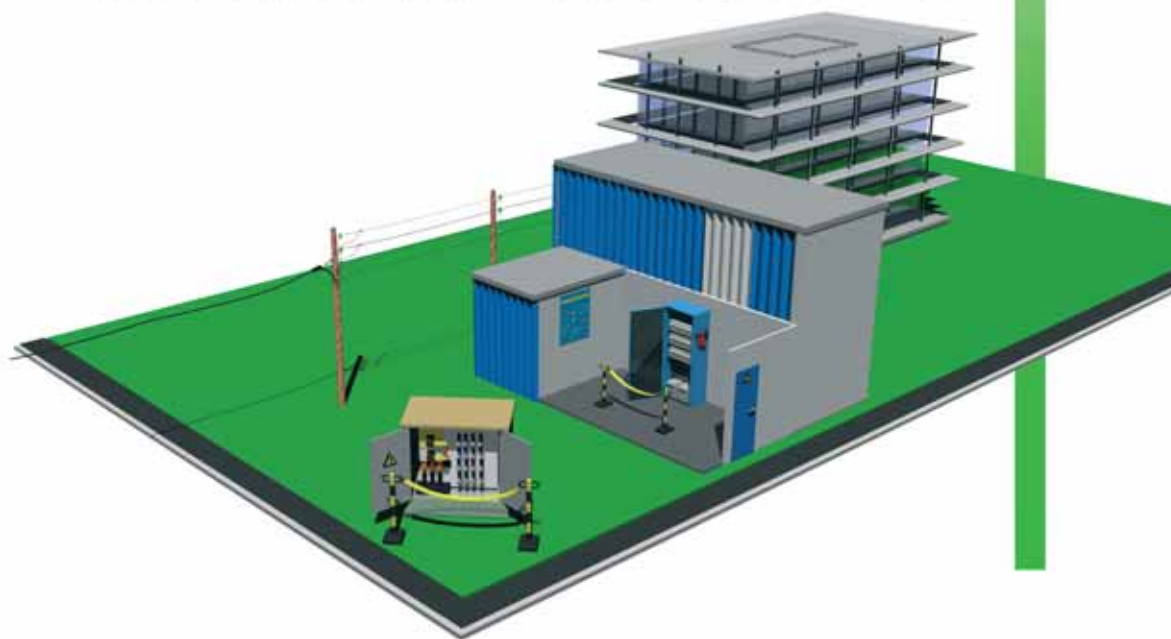

Equipment guide

14

Personal protective equipment

18

Safety padlocks and warning signs

22

Voltage detectors and testers

25

Installation testers

28

Short-circuiting and earthing systems

32

Bimaterial insulated tools

38

Insulated tools

41

LOW VOLTAGE

Examples of usual applications



Home and Building

Since 30 years, CATU has developed a full range of products especially designed for home and building electricians: self adhesive warning signs, personal protective equipment, voltage detectors, installation testers, insulated tools.

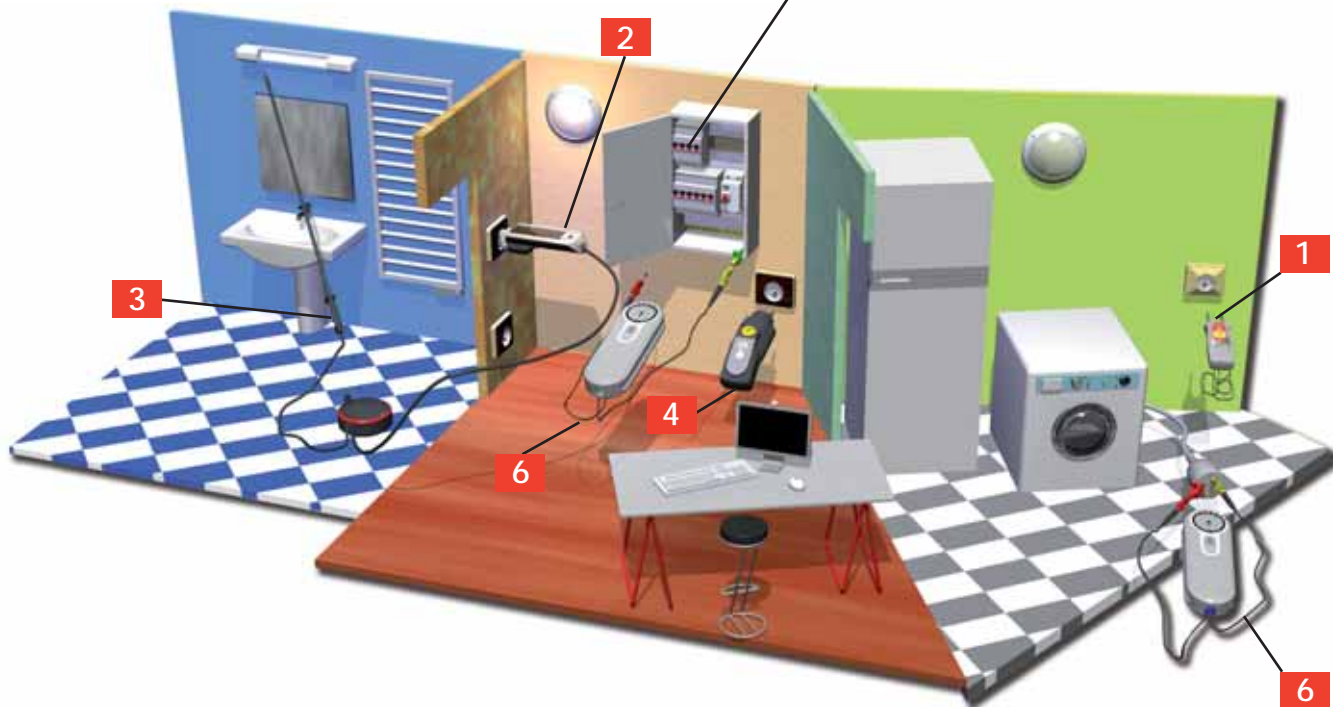

Voltage detector

- | | | | |
|----------|---|----------------------|----------|
| 1 | Bipolar voltage detector 6 to 690 V a.c. / d.c. | Reference: MS-911-EX | Page: 25 |
|----------|---|----------------------|----------|

Installation testers and accessories

- | | | | |
|----------|---|----------------------|----------|
| 2 | Earth and continuity loop controller "CATOHM" | Reference: DT-300 | Page: 30 |
| 3 | Small 2 parts pole for working at distance | Reference: M-95-1143 | Page: 30 |
| 4 | Electrical installation tester 30 and 500 mA "CATEX Pocket" | Reference: DT-110 | Page: 29 |
| 5 | Electrical installation tester 30, 300, 500, 650 mA "CATEX Pro" | Reference: DT-150 | Page: 29 |
| 6 | Insulation Tester | Reference: DT-500 | Page: 28 |
| 7 | Protection and switching devices on L.V. panel | Reference: MX-300 | Page: 29 |
| 8 | Phase order indicator | Reference: MS-152+ | Page: 26 |

Low voltage

APPLICATIONS

Before intervention select the right personal protective equipment

Industry



The full range of our installation testers can fit on any kind of sockets: french, german, U.K., Italian, US.....

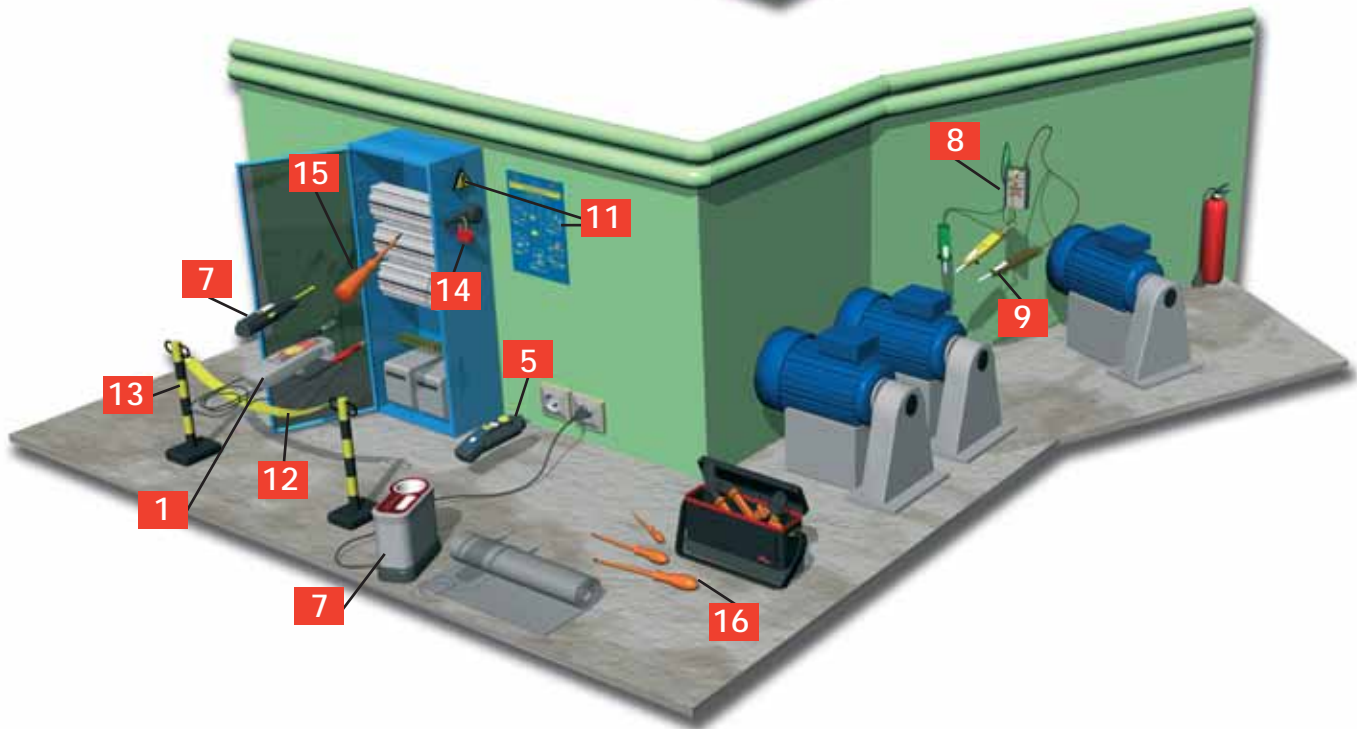

Installation testers and accessories

9 Safety test probes IP2X for controllers Reference: CX- (serie) [Page: 27](#)

Warning signs, safety padlocks and delineators

10 Single pole breaker lockout with padlock Reference: AL-201/C [Page: 22](#)

11 Warning signs aluminium or self adhesive [Pages: 23/24](#)

12 Chain delineator Reference: AL-63-A [Page: 23](#)

13 Safety boundary post Reference: AL-318 [Page: 23](#)

14 Safety padlock Reference: AL-230/.. [Page: 22](#)

Insulated tools

15 Phase tester insulated screwdriver IEC-60900 1000 V Reference: MO-65222 [Page: 41](#)

16 Insulated screwdriver, pliers and accessories IEC-60900 1000 V [Pages: 38 to 51](#)

Low voltage

Examples of usual applications

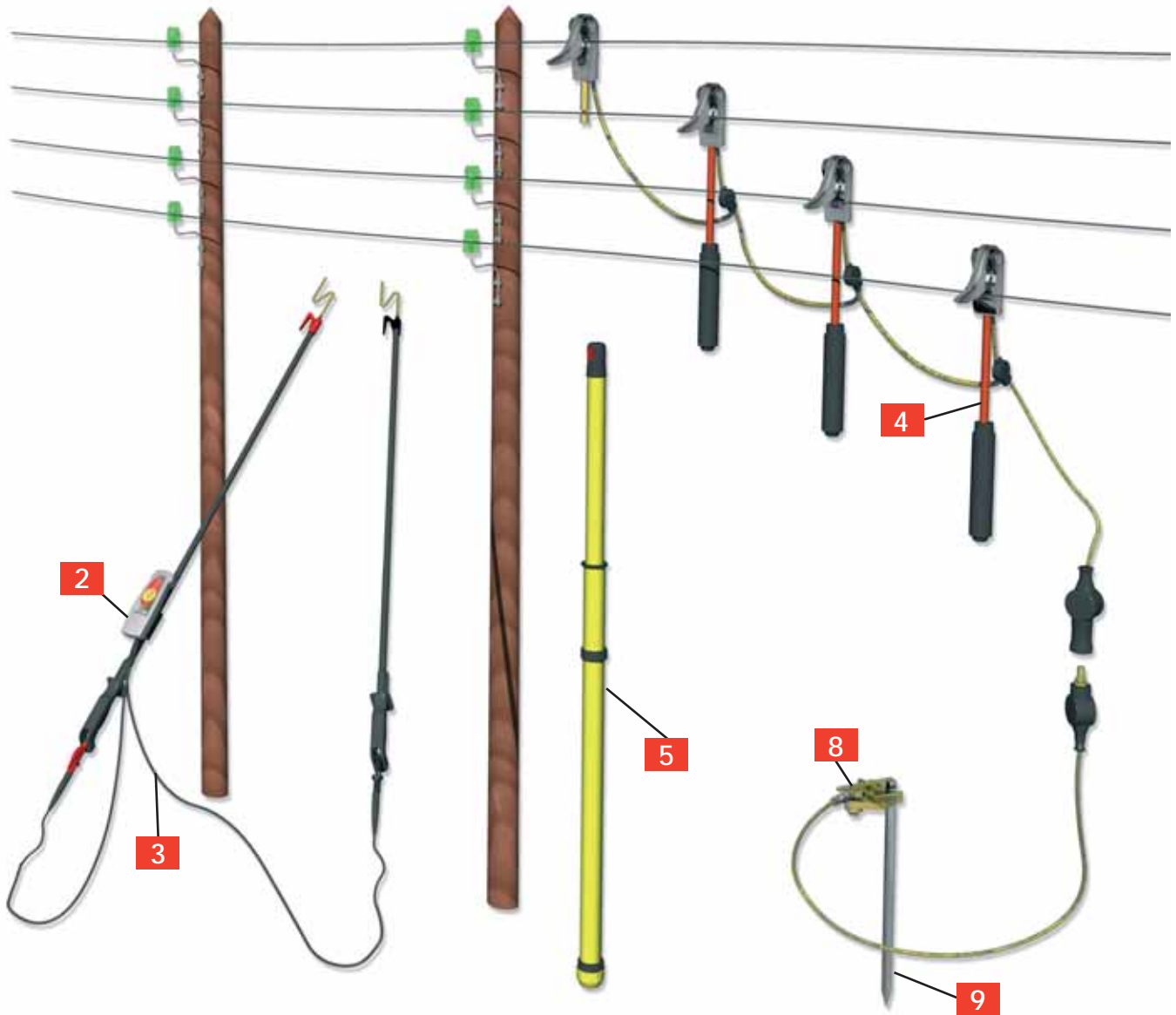

Voltage detectors

- | | | | |
|----------|--|----------------------|----------|
| 1 | Bipolar voltage detector with phase rotation 12 to 400 V a.c. / d.c. | Reference: MS-911/2 | Page: 26 |
| 2 | Bipolar voltage detector 6 to 690 V a.c. / d.c. | Reference: MS-911-EX | Page: 25 |
| 3 | Contact probes for use on bare overhead line length: 1.2 m | Reference: MS-8014 | Page: 27 |

Short-circuiting Systems

- | | | | |
|----------|--|----------------------|----------|
| 4 | Short-circuiting system for bare overhead line with snapping system | Reference: MT-405 | Page: 32 |
| 5 | Insulating stick for short-circuiting bare overhead line system | Reference: CE-2-21-C | Page: 32 |
| 6 | Short-circuiting system for insulated overhead line (sockets system) | Reference: MT-205 | Page: 33 |
| 7 | Short-circuiting and earthing systems for consumer units | Reference: MC-290 | Page: 34 |

Before intervention select the right personal protective equipment

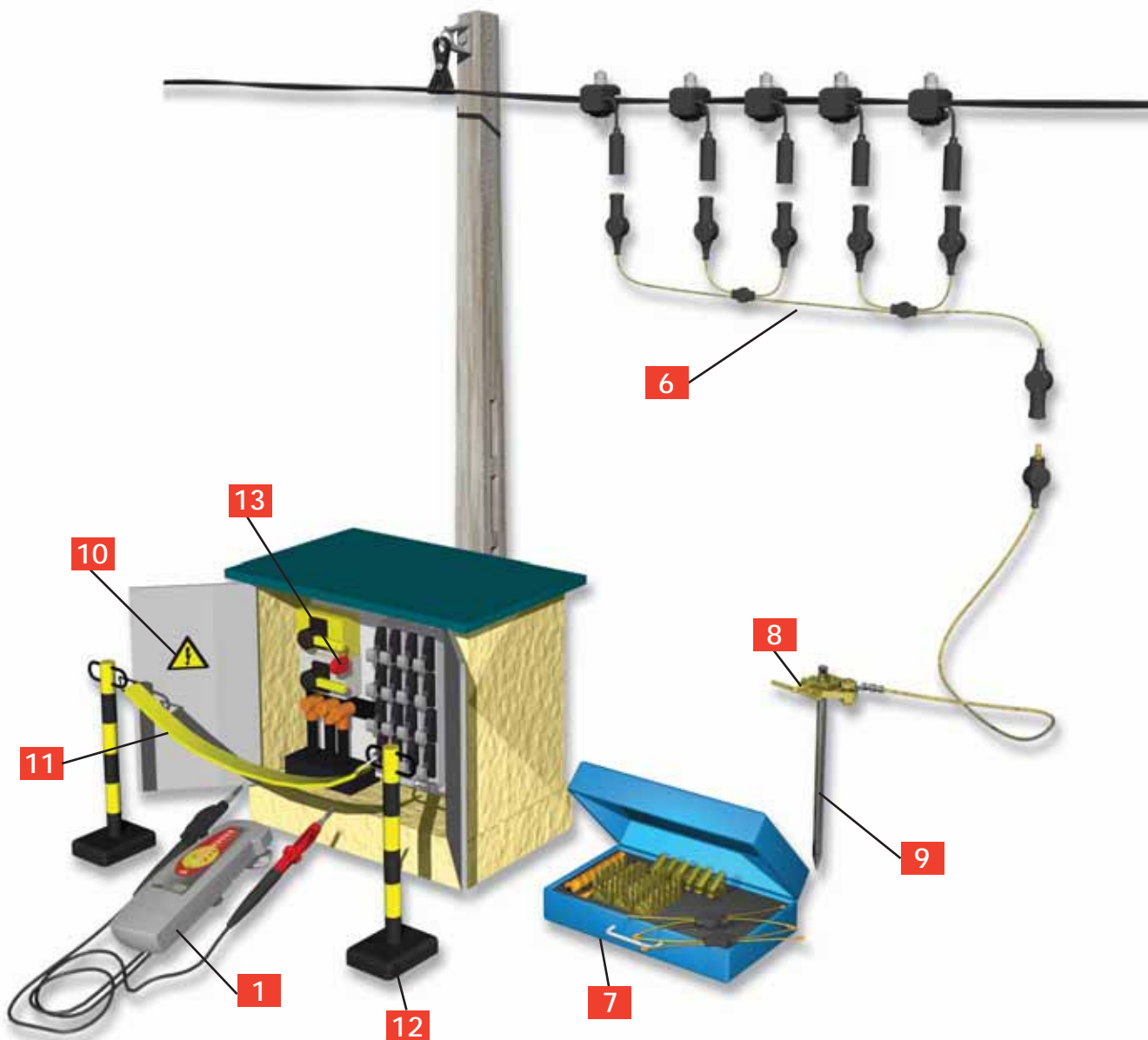

Earthing systems

8	Earthing equipment with cable and earth clamp	Reference: MT-245	Page: 33
9	Hexagonal earth rod length: 1 m	Reference: MT-650	Page: 33

Safety padlocks and warning signs

10	Warning signs aluminium or self adhesive		Pages: 23/24
11	Chain delineator	Reference: AL-63-A	Page: 23
12	Safety boundary post	Reference: AL-318	Page: 23
13	Safety padlock	Reference: AL-230/..	Page: 22

Head and eyes protection

Insulating rubber gloves

Insulating mats and boots

Safety glasses

Protection against UV radiation and ejections of solid particles. Grilamid frame in orange Softflex. Anti-scratch, anti-impact and anti-chemical product treatments. Caution: Do not use for welding operations.

EN 166/EN 170
CE



- MO-11000** Clear lenses, delivered in pouch
- MO-11001** Tinted lenses, delivered in pouch

Overglasses

Polycarbonate overglasses. Protection against UV radiation and ejections of solid particles. Caution: Do not use for welding operations.

EN 166/EN 170
CE



- MO-11010** Clear lenses
- MO-11011** Green tinted lenses

ABS helmet

Electrically insulating helmets for use on voltage installations. Safety industrial helmet, safety helmet for electrical use, especially designed to maximize wearer's comfort. Standard sizes 53 to 63. Leather trim 21 cm along the inside for added comfort. Multiple adjustments for a perfect fit - headband: adjustable in 3 mm increments. Built-in cushion for optimum ventilation. Safety chin strap: fastenings to shell tear resistant. Weight: 0.300 kg.

EN 397
EN 50365
ANSI Z89.1:2003
Class E 20 kV
CE



- MO-182/1-B** White
- MO-182/1-R** Red

Face shield

Polycarbonate face shield adjustable on the head by milled wheel. Protection against electric arcs of short-circuits. Anti-condensation treatment. Caution: Do not use for welding operations.

EN 166/EN 170
CE



- MO-186** Single size, adjustable
- M-881635** Spare face shield for MO-186
- M-87384** Bag for face shield and helmet

Face shield

Face shield adjustable on MO -182 helmet. 100% UV protection. Weight: 0.170 kg. Caution: Do not use for welding operations.

EN 166/EN 170
CE



- MO-184** Single size, adjustable by rubber band

Helmet with built-in face shield

Panoramic face shield in non-scratch and anti-mist polycarbonate. Chinstrap (with Velcro fastening) Head fit adjustment by milled wheel. Single size: 0.270 kg.

EN 166/EN 170/EN 397
EN 50365
CE



- MO-185-BL** White
- MO-185-R** Red
- MO-185-J** Yellow
- MO-185-B** Blue
- M-881622** Spare face shield for MO-185

Polycarbonate helmet

Polycarbonate helmet. Shock and wear resisting, comfortable. Adjustable size from 53 to 63 cm. Weight: 0,465 Kg.

EN 397
CE



- MO-183-BL** White, single size, adjustable
- MO-183-RL** Red, single size, adjustable

Head and eyes protection

Insulating rubber gloves

Insulating mats and boots

Headlamp with adjustable focus

Can be carried either on the head or any type of helmet.
Lighting control and beam by switches.
Range: 30 meters.
Adjustable lamp height angle.
Sealed against rain.
Powered by 4 batteries LR 6.
Autonomy: 6 hours.
Standard bulb 4.8 V/0.3 A.

CE



MS-118 Headlamp - Weight: 0.187 kg

M-95-865 Halogen bulb (sold by set of 5 units)
5.2 V 0.5 A

M-95-864 Hooks set for helmet

LED's Headlamp (3 LED's)

Can be carried either on the head or any kind of helmet.
- Lighting by 3 high performance LEDs.
- 3 lighting levels.
- Adjustable lamp height angle.
- Very light, waterproof IP65.
- Range: 10 to 15 meters.
- Powered by 3 batteries LR03 (AAA).
- Autonomy: 80 hours.

CE



MS-121 Delivered with batteries and a carrying bag
Weight: 0.09 Kg

M-95-864 Hooks set for helmet

LED's headlamp (5 LED's)

LED's Headlamp (5 LED's).
Can be carried on the head or any kind of helmet.
Lighting by 5 high performance white new generation LED's - 3 lighting levels + 1 flash mode + 1 red lighting.
IPX6.
Powered by four batteries LR06 (AA).
Range : 30 meters.
Autonomy : 100 hours.

CE



MS-127 Delivered with batteries and a carrying bag
Weight: 226 g

M-95-864 Hooks set for helmet

Intrinsically safe ATEX LED's Headlamp

II 2GD EEx ia IIC T4
Can be carried either on the head or any kind of helmet.
- Lighting by 3 high performance White LEDs.
- 2 lighting levels (High: 3 LEDs on or low: 1 LED on).
- Adjustable lamp height angle.
- Very light, ABS body.
- ATEX certified Categorie 2 (Zone 1)
N° TRL03ATEX21005X.
- Range: 10 to 15 meters.
- Powered by 3 batteries LR03 (AAA).
- Autonomy: 150 hours.
- Strap: cloth or silicone rubber (for helmet).

CE



MS-126 Delivered with batteries - Weight: 0,125Kg

M-95-864 Hooks set for helmet

Insulating rubber gloves

Insulating rubber gloves conform to international IEC-60903 standard. To satisfy the requirements of this standard, they are subjected to dielectrical, mechanical resistance and ageing tests. The acceptance levels for mechanical tests are stricter. The tests are especially aimed at checking the tensile strength and elongation at break, the mechanical puncture test and tension set. Our gloves are made of latex especially treated to obtain high dielectric characteristics; they are individually tested and delivered in sealed plastic bags.



IEC-60903
CE

Reference	Class	Voltage (V)	Thickness (mm)	Designation	Weight (g)
CG-02 (*)	00	500	1.7	orange composite gloves with mechanical properties	270
CG-05 (*)	00	500	0.5	latex	90
CG-10 (*)	0	1000	1.0	latex	200
CG-10 (*)-AM	0	1000	1.0	two color latex rolled edge	210
CG-12 (*)	0	1000	2.3	orange composite gloves with mechanical properties	450

* References to be completed by size A, B, C, D. Correspondence with standard sizes: A = 8, B = 9, C = 10, D = 11.

Undergloves

Cotton undergloves To be used with insulating rubber gloves.



CE

CG-80 (**) ** H: men / F: women

Pneumatic glove tester

For compulsory control of gloves before use. Checking is done by inflating and immersing in water.



Overgloves

Used as outer glove. Silicon grain leather, very flexible. Large protective cuff in chrome tanned hide. Adhesive strap.



EN 388
CE

CG-98 (*) Weight: 0.170 kg

* Add size: A, B, C, D.

Carrying bag

Made from reinforced waterproof fabric for transport of rubber gloves in vehicles and tool boxes. Rear loop for belt and snaps.



CG-36 60 x 180 x 400 mm - Weight: 0.120 kg

Rubber gloves storage box with window

To be placed in high voltage stations. Insulating material, shock resistant, yellow colour. Transparent window (enables to check gloves presence). Bottle of talc included. Attachment: 4 holes 3.5 mm dia., centre distances 155 x 345 mm. U.V. protection window.



CG-35/1 60 x 210 x 460 mm - Weight: 0.730 kg

Head and eyes protection

Insulating rubber gloves

Insulating mats and boots

Working gloves

All-grain leather, welt sewn, shirred elastic wrist back.



EN 388
CE

CG-96 (*)

Weight: 0.115 kg

* Add size: A, B, C, D.

Correspondence with standard sizes: A = 8, B = 9, C = 10, D = 11

Insulating boots

Made from elastomer canvas support, very flexible and resistant. Anti-perforation stainless steel sole and shell. Anti-slip sole. Protection against step and touch hazardous potential gradients.



EN 345

MV-135*

60 x 210 x 460 mm - Weight: 0.730 kg

* Add sizes: 39-40/41-42-43/44-45-46/47

Insulating stepladders

A complete range with top quality features:
Insulation between two steps: 30 000 V
Lateral risers in polyester/fiberglass
Aluminium alloy rungs with anti-slip coating.



EN 131

Reference	Nbr. of steps	Foot rest height (m)	Reach height (m)	Weight (kg)
MP-700-4	3	0.68	2.68	5.9
MP-700-1	4	0.91	2.81	6.9
MP-700-2	5	1.14	3.04	8.0
MP-700-3	6	1.37	3.27	9.4
MP-700-5	7	1.60	3.50	11

Insulating mats

The matting is manufactured of elastomer compounds with slip-resistant surface. High quality dielectrical rubber.

IEC-61111
EN 61111
CE



Individual models.

Reference	Thickness (mm)	Class	Voltage (kV)	Dimensions (m)
MP-42/11	3	3	≤ 26.5	1 x 1
MP-42/16	3	3	≤ 26.5	0.6 x 1
MP-42/66	3	3	≤ 26.5	0.6 x 0.6

For placing in front of panels.

Reference	Thickness (mm)	Class	Voltage (kV)	Dimensions (m)
MP-60/03-5	3	3	≤ 26.5	0.6 x 5
MP-60/03-10	3	3	≤ 26.5	0.6 x 10
MP-100/03-5	3	3	≤ 26.5	1 x 5
MP-100/03-10	3	3	≤ 26.5	1 x 10

Bags for insulating mats

Specially designed for carrying and protecting insulating mats. Equipped with a shoulder strap and a plastic window for instructions and storage identification.



MP-01

For MP-42/16 and MP-42/66 length: 70 cm

MP-02

For MP-42/11 length: 110 cm

Multi-pockets electrician bag

Specially designed for carrying and protecting insulating mats, face shield and controllers. Equipped with several pockets.



M-87386

65 x 15 x 25 cm

Single pole breaker lockout

Clipblock™, locks lever in off position to isolate and prevent breaker use. Clipblock fits most of standard single pole devices. Quick installation with a flat blade screwdriver N°3 (MO-65203).



AL-201 Delivered in Pack of 5 units

Single pole breaker lockout with padlock

Clipblock™, locks lever in off position to isolate and prevent breaker use. Clipblock fits most of standard single pole devices. Quick installation with a flat blade screwdriver N°3 (MO-65203). Locked by padlock.



AL-201/C Delivered with a padlock

Padlocks with warning signs

Brass ring bow 50 or 70 mm. Diameter of the ring bow 4 or 6 mm.



Reference	Ring bow (mm)	Ø (mm)	Weight (kg)
AL-230-(*)-EX	50	6	0.170
AL-230-S-(*)-EX	70	6	0.190
AL-230-Z-EX	50	6	0.170
AL-230-S-Z-EX	70	6	0.190
AL-240-(*)-EX	50	4	0.170
AL-240-S-(*)-EX	70	4	0.190
AL-240-Z-EX	50	4	0.170
AL-240-S-Z-EX	70	4	0.190

* Add n° of key: 111 or 222
 *00 n° standard key: n° of key upon request
 Z: random n° of key

Handle with 6 padlocks

Handle of moulded plastic for holding up to six padlocks. Compartment with transparent cover for key storage.



Reference	Weight (kg)	Handle with 6 padlocks
AL-236-111-EX	1.150	AL-230-111-EX
AL-236-S-111-EX	1.210	AL-230-S-111-EX
AL-236-222-EX	1.150	AL-230-222-EX
AL-236-S-222-EX	1.210	AL-230-S-222-EX

Multiple locking apparatus

Holds up to four padlocks and a sign.



AL-200	100 x 60 x 10 mm - Weight: 0.150 kg
AL-202	165 x 50 x 12 mm - Weight: 0.200 kg

Handle for 10 and 30 padlocks

PVC. Shock resistant. Ivory colour. With holes Ø 9 mm.



AL-207/10	For 10 padlocks - Weight: 0.06 kg
AL-207/30	For 30 padlocks - Weight: 0.130 kg

Marking

For indelible writing on the warning signs and padlocks, our ALU-SCRIPT™ markers are ideal.



AS-404 4 markers in assorted colors (red, black, blue and green)

Padlocks

Warning signs and delineators

Warning signs

Warning signs

Special tool steel, oil-hardened.



AM-344-GB

AM-345-GB

AM-344/05 - AM-344



AM-49/...

AM-41/...

AM-467-GB

AP-499/1



AM-20-GB



AP-510-BT-GB

Safety adhesive tape

Adhesive tape black and yellow.



AT-5005 Length: 100 m

Chain delineators

Polyamide chains.



AL-31/25



AL-32/05

AL-31/25 Red and white - Length: 25 m

AL-31/05 Red and white - Length: 5 m

AL-32/05 Black and yellow - Length: 5 m

AL-31 Opening ring for AL-31/25

Safety boundary post

For temporary installation used with tough link chain delineators. Removal foot Ø 50 mm Length: 0.9 m.



AL-316

AL-318

AL-316 Red and white - Weight: 4.2 kg

AL-318 Black and yellow - Weight: 4.2 kg

Fixing tools for warning signs



AC-21

AC-44

AD-01

AC-21 Small nickelled chain sold in bags of 10 units

AD-01 Roundheaded screw anti-vandalism M3x15 sold in bags of 100 units

AC-44 Self-adhesive plastic plates Ø 40 mm for magnetic fixing (10 units)

Reference	Type	Dimensions	Characteristics
AM-344-GB	aluminium	100 mm side	black letters on yellow
AM-345-GB	aluminium	100 mm side	black letters on yellow
AM-467-GB	aluminium	Ø 80 mm	white letters on red
AP-510-BT-GB	plastic	297 x 210 mm	golden rules
AM-344	aluminium	100 mm side	black or yellow
AM-344/05	aluminium	50 mm side	black or yellow
AM-49/1	aluminium	100 mm side	black or yellow
AM-49/2	aluminium	200 mm side	black or yellow
AM-41/1	aluminium	100 mm side	black or yellow
AM-41/2	aluminium	200 mm side	black or yellow
AM-20-GB	aluminium	350 x 250 mm	blue letters or plain aluminium
AP-499/1	plastic	Ø 100 mm	white or red

Delineators

Brightly colored ribbon. Snap hook on one ribbon end and another on spool. A ring on spool brakes ribbon at desired length. wide: 50 mm length: 20 m.



AL-62-A

AL-63-A

AL-62-A Red ribbon

AL-63-A Yellow ribbon

Plastique consommable. Length: 500 m. Wide: 70 mm.



AL-138

AL-138 Red and white

Self adhesive warning signs

Complete range of self adhesive, warning signs conditioned in box of 20, 30 or 50 units.



Reference	Dimensions	Characteristics	Quantity/box
AT-41/025	25 mm side	self adhesive PVC	50
AT-41/05	50 mm side	self adhesive PVC	30
AT-41/1	100 mm side	self adhesive PVC	20
AT-49/025	25 mm side	self adhesive PVC	50
AT-49/05	50 mm side	self adhesive PVC	30
AT-49/1	100 mm side	self adhesive PVC	20
AT-50/025	25 mm side	self adhesive PVC	50
AT-50/053	50 mm side	self adhesive PVC	30
AT-50/1	100 mm side	self adhesive PVC	20
AT-51/025	25 mm side	self adhesive PVC	50
AT-51/05	50 mm side	self adhesive PVC	30
AT-51/1	100 mm side	self adhesive PVC	20
AT-52/05	50 mm side	self adhesive PVC	30
AT-52/1	100 mm side	self adhesive PVC	20
AT-53/05	50 mm side	self adhesive PVC	30
AT-53/1	100 mm side	self adhesive PVC	20
AT-54/05	Ø 50 mm	self adhesive PVC	30
AT-54/1	Ø 100 mm	self adhesive PVC	20
AT-55/05	Ø 50 mm	self adhesive PVC	30
AT-55/1	Ø 100 mm	self adhesive PVC	20
AT-56/05	Ø 50 mm	self adhesive PVC	30
AT-56/1	Ø 100 mm	self adhesive PVC	20
AT-57/05	Ø 50 mm	self adhesive PVC	30
AT-57/1	Ø 100 mm	self adhesive PVC	20
AT-58/05	Ø 50 mm	self adhesive PVC	30
AT-58/1	Ø 100 mm	self adhesive PVC	20
AT-59/05	Ø 50 mm	self adhesive PVC	30
AT-59/1	Ø 100 mm	self adhesive PVC	20
AT-60/05	Ø 50 mm	self adhesive PVC	30
AT-60/1	Ø 100 mm	self adhesive PVC	20
AT-61/05	Ø 50 mm	self adhesive PVC	30
AT-61/1	Ø 100 mm	self adhesive PVC	20
AT-62/05	Ø 50 mm	self adhesive PVC	30
AT-62/1	Ø 100 mm	self adhesive PVC	20
AT-63/05	Ø 50 mm	self adhesive PVC	30
AT-63/1	Ø 100 mm	self adhesive PVC	20
AT-66/1	100 mm side	self adhesive PVC	10

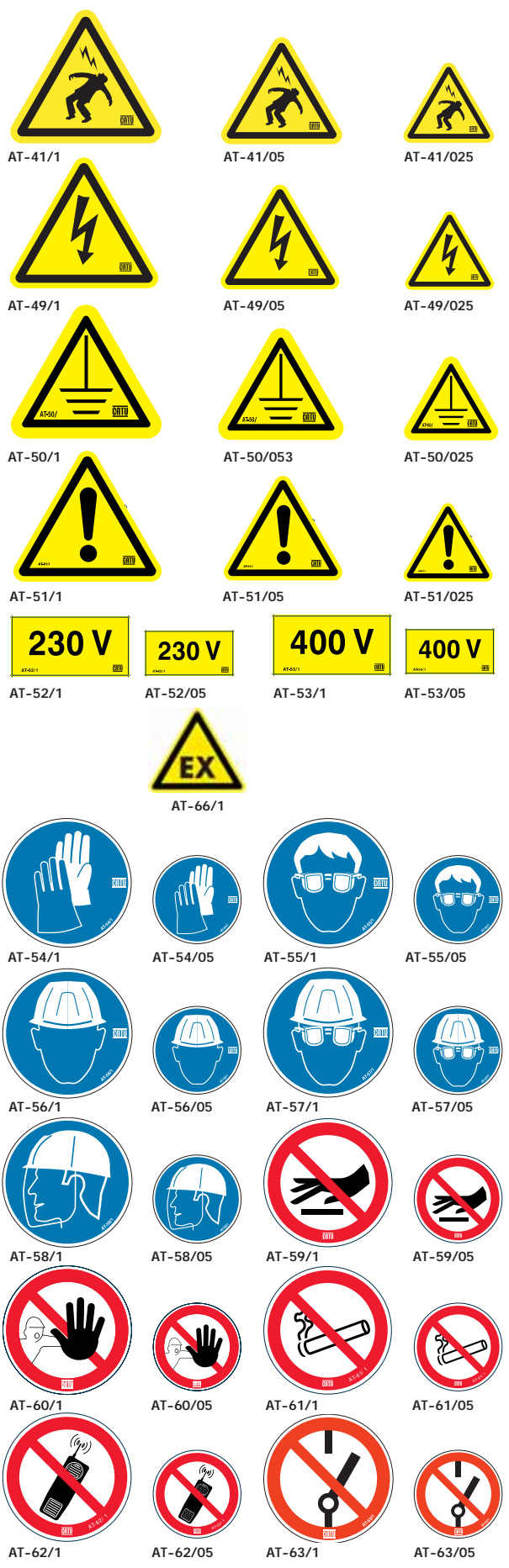

"Customize your labels! On request"

Available on request: Self adhesive rigid plastic warning signs. High Quality, strong sticking on every surfaces: concrete, painted wall, metal, wood, plastic, glass.

Voltage multi-tester DETEX™ 911-EX

The DETEX 911-EX has been designed in compliance with IEC/CENELEC standard 61243-3 in response to the requirements of European standard EN 50110-1.

The device is a voltage detector which checks the absence of voltage (AC and DC) and a multi-tester.

It enables to:

- check the voltage levels from 6 to 690 Volts;
- check the continuity of disconnected electric circuit;
- find phase or neutral (by single pole method);
- determine polarities.

A.C or D.C voltage test

voltage level testing by light-emitting diodes: 6, 12, 24, 50, 127, 230, 400, 690 V and emission of audible signal.

Polarity Test

Presence of A.C voltage signalling by lighting of +6 and -6 V diodes.

Presence of D.C voltage signalling by lighting of the +6V or -6V diode.

Phase/neutral identification

Signaling by lighting of the + 6V diode when the red probe is in contact with the phase.

Continuity test

Continuity resistance lower than 80 Ohms is indicated by lighting of all diodes and emission of audible signal.

Operating check

By short-circuit on the probes; all of the diodes light up, the audible signal sounds.

Technical features

Field of use: from 6 to 690 V ~ or =

Frequency: 50-60 Hz

Operating temperature: -10 °C / +55 °C

Storage temperature: -25 °C / +55 °C

Protection level: IP54 / IK 06

Double insulation Class II

Power supply by 9 volt 6LR61 type alkaline battery

IEC 61243-3



IEC-61243-3
EN 50110-1
CE



Fits on safety power plug (patented)

MS-911-EX

Delivered with power supply
Weight: 0.370 kg

ACCESSORIES

M-87369

Storage Bag



M-87369
Storage bag

Voltage multi-tester with phase rotation DETEX™ 911/2

The DETEX 911/2 has been designed in compliance with IEC/CENELEC standard 61243-3 in response to the requirements of European standard EN 50110-1.

The device is a voltage detector which checks the absence of voltage (AC and DC) and a multi-tester.

It enables to:

- check the voltage levels 12 to 400 Volts;
- check the continuity of disconnected electric circuit;
- find phase or neutral (by single pole method);
- Control the phase rotation;
- Determine polarities.

It is equipped with IP2X safety test probes.

A.C or D.C voltage test

voltage level testing by light-emitting diodes: 12, 24, 50, 127, 230, 400V and emission of audible signal.

Polarity Test

Presence of A.C voltage signaling by lighting of +12 and -12 V diodes.

Presence of D.C voltage signaling by lighting of the +12V or -12V diode.

Phase/neutral identification

Signaling by lighting of the + 12V and -12V diodes with audible signal when the red probe is in contact with the phase.

Phase rotation

Signaling by lighting of a green diode when the rotation is correct and by a red diode when the rotation is not correct.

Control method with only two safety test probes.

Continuity test

Continuity resistance lower than 80 Ohms is indicated by lighting of all diodes and emission of audible signal.

Operating check

By short-circuit on the probes; all of the diodes light up, the audible signal sounds.

MS-911/2	Delivered with power supply Weight: 0.370 kg
----------	---

M-87369	Storage Bag
---------	-------------



IEC-61243-3
EN 50110-1
CE

Technical features

- Field of use: From 12 to 400 V A.C and D.C
- Frequency: 50/60 Hz
- Operating temperature: -10/+55°C
- Storage temperature: -25/+55°C
- Protection level: IP54
- Double insulation Class II
- Power supply by 9 volt 6LR61 type alkaline battery

Phase order indicator DETEX™ 152+

Signaling via the successive lighting of diodes symbolising rotation. Input terminals are connected to the corresponding phases (green, yellow, brown):

correct connection: lighting according to "OK" order, incorrect connection: "REVERSE" order lighting: reverse 2 phases.

"FAULT" diode lights: phase cut off or incorrectly connected.

90 to 400 V - 50/60 Hz / IP54 IK06 / CAT III.

Works on generating units.

Device delivered in storage bag with:

- 3 probes with retractable protectors and 1.20 m lead - yellow, green and brown - clamps - yellow and brown,
- 2 insulated crocodile clamps.

MS-152+	Delivered complete with storage bag Weight: 0.380 kg - 60 x 100 x 25 mm
---------	--



IEC-61557-7
EN 50110
CE

Works on generating units

Contact probes for L.V. tester

To be used only with MS-911/2 tester.

For overhead lines

Contact antennas serve as suspension hooks.

Marked with standard colours: black and red.

Total length: 1.25 m.

MS-8014 2 probes, in bag 50 x 130 x 1.300 mm - 0.40 kg



MS-8014

To be used only with MS-911/2 tester.

For installations

Round tip contact. Total length: 0.50 m.

MS-8013 2 probes, in bag 50 x 150 x 470 mm - 0.750 kg



MS-8013

Voltage take-off punch

The voltage take-off punch is enable to make an insulating piercing on a low voltage wire to plug a measurement device.

Fit with pin or safety test probe with 4 mm diameter.

Reference	Capacity (Ø mm)	Weight (kg)
MS-62	5.6 - 14.4	0.015
MS-63	12 - 31	0.05



POINTEST™ Safety test probes for voltage detectors

Safety test probe for voltage detector use only.

4 mm retractable shrouded plug, 4 mm standard socket or 1,20 m double sheathed lead,

Probe 26 mm length, 1000 V A.C or D.C, IP2X.

IEC 61010-2-031

CE

CX-35811 Green safety test probe 1.20 m lead

CX-45211 Brown safety test probe 1.20 m lead

CX-45511 Black safety test probe 1.20 m lead

CX-45411 Yellow safety test probe 1.20 m lead



Safety crocodile clamps

Crocodile clamps.

Fully insulated crocodile clamps with large jaw opening: 20 mm.

IEC 61010-2-031

CE

CX-01222 5 brown crocodile clamps

CX-01422 5 yellow crocodile clamps

CX-01822 5 green crocodile clamps

DX-02006 2 crocodile clamps - black and red



Insulation tester

 CEI 61010-1
 EN 61557-2
 CE

The insulation resistance of an installation must be checked periodically and when it is commissioned. Furthermore, a measurement of the insulation resistance of the entire installation (or group of circuits) may be necessary when troubleshooting.

Operating principle

The measurement voltage shall be 500 V DC (for installations operating at 500 V or less) in order to detect any insulation defect between two cables that are normally isolated from each other. The choice of a high test voltage provides an easier means of demonstrating a latent insulation fault (conventional ohmmeters only output a few volts).

An installation is declared to be conform if the insulation resistance is $> 500 \text{ k}\Omega$.

The DT-500 insulation tester provides an easy, fast and safe means of making this measurement.

The insulation tester DT-500 is designed to test in total safety the insulation resistance of a low voltage installation.

DT-500 is equipped with:

- 3 safety test probes IP2X
- 1 red safety test probe (phase)
- 1 Yellow/green safety test probe (earthing)
- 1 blue safety test probe (neutral) raccordable (Fig.3) on a safety plug
- 3 safety crocodile clamps (red, yellow/green and blue).

It enables to test the insulation resistance between each active wire and the earth (Fig.1). For fragiles receptors (electronics), we recommend to use the third blue test probe.

In this configuration, the neutral and the phase are linked together which avoids any damage on electronic components (Fig.2).

Insulation resistance test

When the DT-500 is connected to a low voltage switch off installation it output 500 V DC.

Signaling by a blue flashes diode. During the measurement the diodes light up in sequence.

The value is indicated on one of the diodes:

Red beetween: 0, 300, 400 k Ω .

Green beetween: 500, 600, 700, 800, 900, 1000 k Ω and ∞ .

Complete safety

The DT-500 is equipped with a safety system. If it is connected on a live installation, a flashes red warning diode light and measurement is impossible.

Technical characteristics

our insulation tester is designed according to standard EN 61557-2.

It also respects international electrical safety standard IEC 61010-1.

- Output voltage 500 V DC.
- Nominal output current at 500 V: 1 mA.
- Measurement range 0 + ∞ .
- IP54, IK06.
- Batteries 4 x LR6.
- Size 213 x 75 x 46 mm.
- Storage temperature: -25 °C/+70 °C.
- Usage temperature: -15 °C/+45 °C.

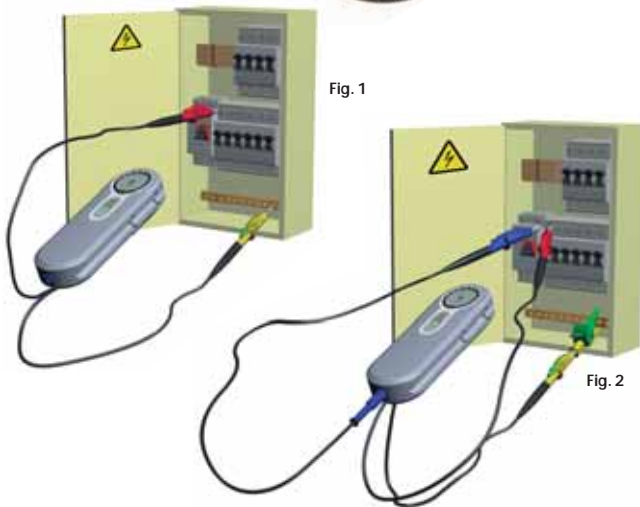

Fig. 3



M-87-292

DT-500

Delivered complete with batterie, accessories and a storage plastic case - Weight: 0.6 kg

M-87292

Storage bag for DT-500 - 280 x 180 x 70

IDENTEX™ protection and switching devices identifier on L.V. panel

CE

Identex MX-300 makes it possible to identify the origin of a source of voltage on the wire conductors connected to protection devices (cut-offs, magnothermal circuit breaker, interdifferentials) on panel. This operation is carried out without switching off the main power supply. The identification of a socket, ceiling light fitting or an electric motor connection is therefore easily carried out under voltage. Identex is composed of two active parts: a current extractor and a receiver.

Technical characteristics:

Voltage of use: 230 or 400 V 50 Hz +/- 10%

Use Temperature: 0°C/+40°C

Degree of protection: IP20, IK06

Class I reinforcement insulation (current extractor)

Complies with standards: EN-61010-1 & IEC-664

Possible detection of the signal with max network current of 80 A.



MX-300	Delivered complete with all its connection supply
---------------	---

ACCESSORIES

M-951735	Connection lead for 230 V connector 1.5 m length
M-951736	Set of black and red leads 2.5 m length
DX-02006	Set of black and red crocodile clamps

Electrical installation testers CATEX™

"TT, TN" network

The CATEX testers enable you to perform the following checks:

Presence of voltage at the terminals of a socket, integrity of the earth circuit, correct polarity:

the position of the phase and the neutral

is indicated, correct operation of the ELCB system at the following sensitivities, 30 mA, 100 mA, 300 mA, 500 mA, 650 mA.

The ELCB check function is only applicable to single phase circuits:

230 V between phase and neutral or between phases (DT-102).

Operating voltage: 230 V +/- 10%

Frequency: 50/60 Hz +/- 10%

Operating temperature: -15°C / +45°C

IP 40 IK03

Fuse protection: 2 delayed fuses 250 mA.

IEC 61010-1

CE

DT-110	Range: 30, 500 mA - Ph/N For use on standard socket
DT-150	Range: 30, 300, 500, 650 mA - Ph/N For use on standard socket, delivered with bag
DT-102	Range: 30, 100, 300 mA- Ph/N and 30, 100, 300 - Ph/Ph For use on French and German socket
DT-157	Range: 30, 100, 300, 500 mA For use on UK socket

ACCESSORIES

M-952271	Lead set for checks on L.V distribution board (for DT-110/DT-150/DT-300 only)
-----------------	---



Earth and continuity loop controllers CATOHM™

"TT" network

The CATOHM earth and continuity loop controller enables:

- checking electrical resistance level of local earth socket, indicating by LCD display:
 - back lighting blue (1) if the value is above 100 Ω
 - back lighting red (3) if the value is - uper than 100 Ω
 - incorrect voltage (2)
 - earth not corrected (2)
- checking the presence and level of voltage at the connection terminals of a live 10/16 A socket,
- checking the integrity of the earth circuit (continuity < 2 Ω), correct polarity (position of the phase and the neutral is indicated),
- checking electrical continuity of metal masses.

Operating voltage: 230V - 10% / + 6%

Frequency: 50/60 Hz

Temperature of use: -15°C/+45°C

IP 40

Fuse protection: 2 fuses 5 x 20 mm, 160 mA, (delayed fuse).

Class II category III

Delivered with wound-up extension.

Weight: 0.340 kg.

Dimensions: 71 x 210 x 51 mm.

IEC 61010-1
EN 61557-4
CE



Figure 1



Figure 2



Figure 3



DT-300



Figure 4

DT-300

For use on schuko socket

DT-307

For use on UK socket

ACCESSORIES

M-92-1172

Winder

M-87-292

Storage bag

M-952271

Lead set for checks on L.V distribution board (for DT-110/DT-150/DT-300 only)

M-95-1143

Small 2 parts pole for working at a distance - 0.8 m



DT-307



M-87292



M-952271



M-951143



M-921546

Digital multimeter- Cat III 600 V

This digital multimeter is compact 3 1/2 digit.
For measuring DC and AC voltage and current, resistance, continuity and temperature.

- AC frequency response: 40 - 400 HZ
- DC voltage: 200 mV/2 V/20 V/200 V/1000 V ($\pm 0.5\% +3$)
- AC voltage: 200 mV/2 V/20 V/200 V/750 V ($\pm 0.8\% +5$)
- DC current: 2 mA/20 mA/200 mA/20 A ($\pm 0.8\% +3$)
- AC current: 2 mA/20 mA/200 mA/20 A ($\pm 1.0\% +5$)
- Resistance: 200 Ω /2 k Ω /20 k Ω /200 k Ω /2 M Ω /20 M Ω /2000 M Ω ($\pm 0.8\% +3$)
- Capacitance: 20 μ F 200 μ F/2 μ F/20 μ F/200 μ F ($\pm 2.5\% +20$)

General specifications

- 3 1/2 digital multimeter, 30 ranges, 70 x 50 mm LCD display, 1999 counts max.
- Back light, data hold
- Diode, triode performance testing, continuity test (audible)

General characteristics

- Battery: 2 x 1.5 V AAA batteries
- Low battery indication level on LCD
- Operation temperature: 0°C / 40°C, < 75%RH
- Storage temperature: -20°C / 60°C, < 85%RH



MX-701 189 x 97 x 35 mm - Weight: 315 g

Digital clamp meter - Cat III 600 V

This digital clamp meter is compact 3 1/2 digit.
Aurorange for measuring DC and AC voltage, AC current, resistance, diode, continuity and temperature.

- AC current: 2 A - 600 A.
- AC voltage: 2 V - 600 V. DC voltage: 0.2 V - 600 V.
- Resistance: 200 Ω - 20 M Ω . Continuity: buzzer (< 50 Ω).
- Temperature range: -40°C/+1000°C -40°F/-1832°F.

General specifications

- Display: 3 1/2 digit LCD with a max. reading of 1999
- Polarity: auto polarity indication
- Overrange indication: "OL" or "-OL"
- Automatic zeroing function
- Sensor: clamp-shape transformer for AC measurement
- Jaw opening capability: \varnothing 36 mm
- Max. measurable conductor: \varnothing 30 mm

General characteristics

- Battery: 2 x 1.5 V AAA batteries
- Low battery indication
- Operation temperature: 0°C / 40°C, < 75% RH
- Storage temperature: -20°C / 60°C, < 85% RH



MX-702 190 x 70 x 38 mm - Weight: 220 g

POINTEST™ Safety test probes for multimeter and clamp-meter

Safety test probes for multimeter and clamp-meter use only.
4 mm retractable shrouded plugs, 4 mm standard socket or 1.20 m double sheathed lead,
Probes 26 mm length, 1000 V A.C or D.C, IP2X.

DX-02001 Set of 2 contact probes, black and red with socket

DX-02002 Set of 2 contact probes, black and red 1.20 m lead



Short-circuiting systems for bare L.V. overhead lines

For conductors: 3 - 15 mm Ø.
 Easily attached by snapping on with a firm downward pull.
 Released by lateral swinging, no need to push upwards.
 First grip installed by insulating stick.
 First clamp/stick connection has automatic ratchet.
 Waterproof bag.
 To be completed with earthing equipment. See page 28.

IEC 61230

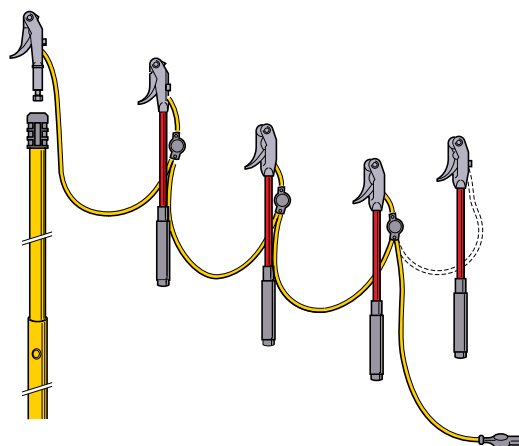

Packaging: waterproof bag 250 x 85 x 1160 mm.

Reference	Rating (kA/1s)	Short-circuit cables (mm ²)	Weight (kg)	Number of clamps	Insulated telescopic stick
MT-404	3	16	3.4	3 MT-411/1 MT-411-C	CE-2-21-C/length: 2 m
MT-405	3	16	3.8	4 MT-411/1 MT-411-C	CE-2-21-C/length: 2 m
MT-406	3	16	4.2	5 MT-411/1 MT-411-C	CE-2-21-C/length: 2 m
MT-407	3	16	4.6	6 MT-411/1 MT-411-C	CE-2-21-C/length: 2 m

Short-circuiting and earthing systems

Lowlock system:
 For conductors 3 to 21 mm Ø.
 With clamps type "snap-on/screw-on".
 Connecting cables: 35 mm² copper.

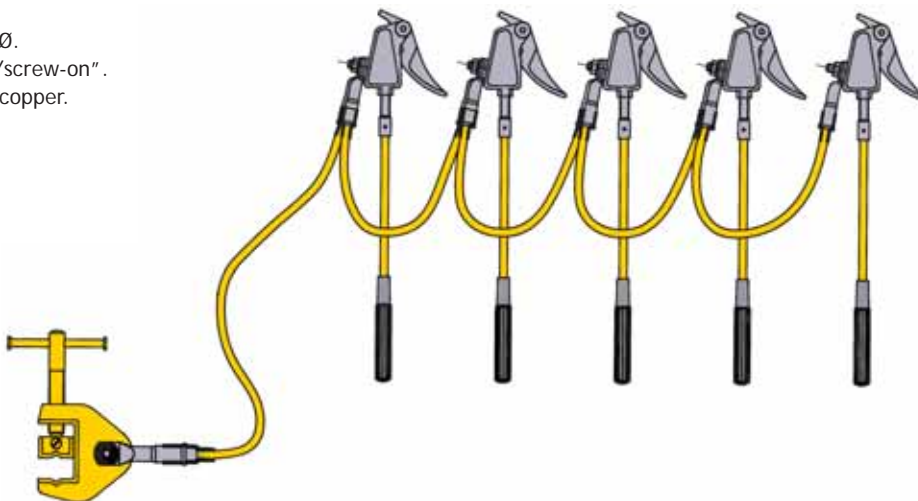

Reference	Rating (kA/1s)	Weight (kg)	Composition
MT-615/1-7,5	7.5	3	5 MT-616/1-03 contact clamps on handles (l = 0.35 m each) 4 braids of M-24-35 copper cable (1.00 m) 1 M-87-153 carrying bag 250 x 85 x 750 mm
MT-615/2-7,5	7.5	6.5	5 MT-616/1-03 contact clamps on handles 4 braids of M-24-35 copper cable (1.00 m) 1 braid of M-24-35 copper cable (7.00 m) 1 MT-840/1 earth clamp

For other models, please consult us.

Short-circuiting systems for insulated L.V. overhead lines

Connected to female sockets permanently installed on power lines. Equipment includes either 5 or 6 copper-aluminium alloy stubs with bayonet locking and insulating cap. To be completed with earthing equipment. See below.

IEC 61230

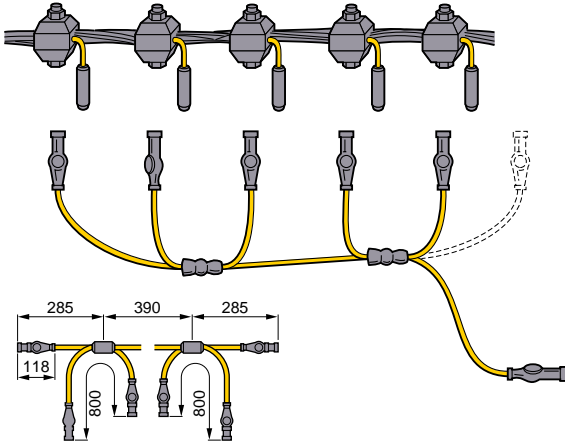

Packaging: polypropylene case - 234 x 215 x 75 mm.

Reference	Rating (kA/1s)	Short-circuit cables (mm ²)	Weight (kg)	Composition
MT-205	4	16	1.10	5 stubs
MT-206	4	16	1.50	6 stubs
MT-207	4	16	1.9	7 stubs

Earthing equipment

Earthing equipment with bayonet splicing. Earth rod to be ordered separately. See below.

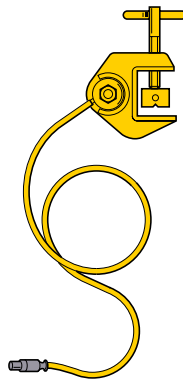

Packaging: polypropylene case - 310 x 280 x 105 mm.

Reference	Weight (kg)	Cable (m x mm ²)	Earth clamp
MT-245	3.0	10 x 16	MT-840/1
MT-249	3.8	15 x 16	MT-840/1

Earth rod

For use with earthing equipment
Hexagonal 18 mm per side.
Galvanized steel.



MT-650	Length: 1 m - Weight: 2.2 kg
--------	------------------------------

Short-circuiting system for consumer units

The link assemblies, included in this equipment, consist of extra flexible 16 mm² multistrand copper cable with an IEC 1230 silicone envelope, recommended for indoor equipment.

The elements contained in the case can be used for establishing the equipment suited to the unit to be processed. The cartridge equipment is intended for HBC 22 x 58 mm fuse cartridge connection boxes and knife cartridges size 00. The knife equipment is intended for connection boxes or knife switch networks.

The mini-clip equipment is designed for the short-circuiting of take-off boxes more particularly using intermediate parts (sockets with 10 mm Ø terminals and M8 hexagonal end). The standard equipment for a three phase installation includes: the sets of cartridges, knives or mini-clips for adaptation to any type of unit, the interconnecting assemblies consisting of 4 extra flexible 16 mm² copper cables connected at the center by a connector, 1 installation and crimping kit. Rating: 4 kA/1s Weight: 4.3 kg.

Reference	Composition
MC-290/2	8 cartridges 8 cartridges type "00" 8 clamps 8 M8 connections 2 (280 x 320 mm) cable connections 2 (370 x 440 mm) cable connections 1 M8 key wrench 1 right angle hexagonal key wrench 4 mm 1 13/17 and 14 mm open end spanner 1 handle MC-161



Short-circuiting system for L.V equipment ISOSTOP™ system

Rating: 6 kA/1S
 Standard equipment composition: 1 or 2 sets of 3 knives, cables connections: H07 RN-F 25 mm², 1 earth clamp MT-841 1 handle MC-161.

Reference	Composition	Weight (kg)
MC-165/40	3 MC-160 earth cable 0.60 m	4.00
MC-175/40	3 MC-115 earth cable 0.60 m	3.75
MC-166/40	3 MC-115 3 MC-160 earth cable 0.60 m	5.60
MC-166/60	3 MC-115 3 MC-160 earth cable 6 m	4.20



Jumper cable with clamps on insulated handle

2 clamps on insulated handle - MT-315
 Capacity (mm): Ø 4 - 27 - 40
 Cable connection: 35 mm²
 Rating: 6 kA/1s
 Continuous rating: 75 A
 Clamp material: copper aluminium alloy
 1 insulated cable
 Length: 1 m, Section: 25 mm².

MT-315/2	Dimensions: 40 x 60 x 910 mm - Weight: 0.530 kg
----------	---



Short-circuiting equipment

Connecting set formed by extra flexible multi-strand copper cables 16 mm² with silicon sheath according IEC-61230. Wide use temperature range (-40°C, +70°C). No toxic smokes emission in case of short circuit.

IEC 61230

Reference	Designation
MC-296-440	Connection set 440 + 370 mm*
MC-296-320	Connection set 320 + 280 mm*

* Other models and length on request.

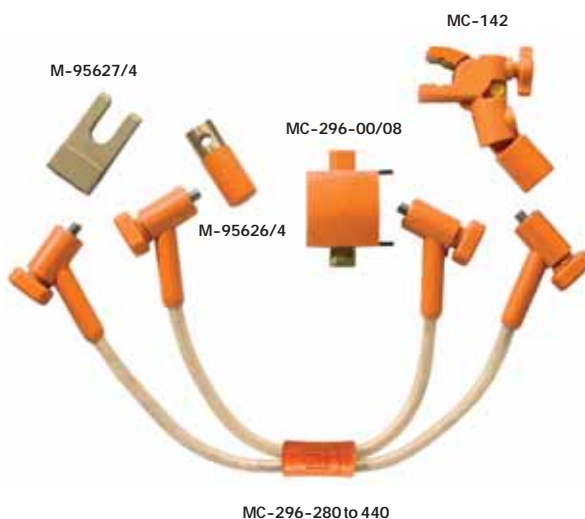

Set of: cartridge, connecting blade and jumper clamp.

Reference	Designation
M-95627/4*	Connecting blade
M-95626/4*	Round cartridge HPC 22 x 58
MC-296-00/08*	Cartridge size 00
MC-142	Jumper clamp

* Set of 4.

MC-296-115/12 or MC-296-115/08

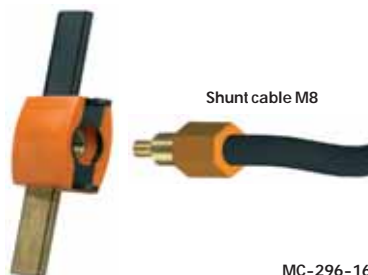

MC-296-160/12

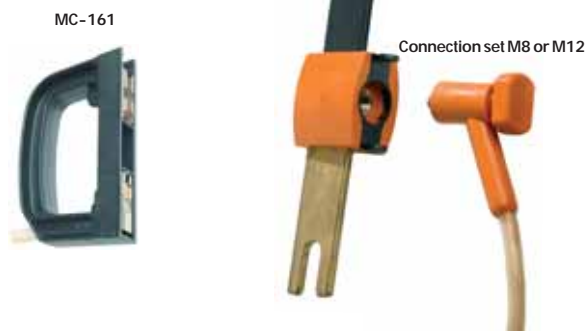

MC-161	Manœuvring handle
--------	-------------------

Case (340 x 250 x 80 mm) for specific set. Réf.: M-91209.

Connecting blades M8 or M12

Reference	Designation
MC-296-115/08*	Between axes 115 mm M8
MC-296-115/12*	Between axes 115 mm M12
MC-296-160/12*	Between axes 160 mm M12

* Set of 4.

To be used with jumper cable (M8 or M12) connection cable (on request).

Additional equipment:

- Jumper cable (see page N°36)
- Threaded adapter (see page N°37)



Mini jumper clamps fully insulated for switchboard use

These clamps are specially designed for use on energized parts in LV installations (switchboards, etc.) to make temporary connections when limited space is available. Models with jaws designed to axially grip conductors can be used on threaded bolts or shanks and nuts. The MC-142 model, whose size has been reduced to the strict minimum, is designed to be tightened with a nut wrench. All other models in this series tighten with T-handle screw. All clamps receive cable terminals with ISO 8 mm pitch threading as in the MC-153 series (described below). Current rating: 200 A.



Reference	Clamp capacity to main conductor	Orientation with respect	Size (mm)	Weight (kg)
MC-141	Six-sided 17-19 mm		71 x 150 x 24	0.26
MC-142	Round 6-10 flat 0-5 mm	Axial (at cable end) + transversal	58 x 38 x 33	0.130
MC-143	Flat bar, thickness 2-25 mm		67 x 145 x 26	0.230
MC-144	Round 8-12 square 9-10 mm	Axial (at cable end)	150 x 75 x 23	0.280
MC-145	16-75 mm ²	Transversal	110 x 70 x 23	0.220
MC-146	38-240 mm ²	Transversal	110 x 70 x 23	0.230
MC-147	Threaded rod M8		66 x 98 x 25	0.18
MC-147/1	Threaded rod M10		66 x 98 x 25	0.195
MC-148	Clamp with tapped revolving rod end M8, 200 A shunt. To be used with an insulated six-sided male hex key 5 mm.		66 x 80 x 25	0.175
MC-148/1	Clamp with tapped revolving rod end M8 for 10 to 50 mm cable		66 x 80 x 25	0.175
MC-149	Bar 20-30 mm width		56 x 165 x 58	0.486

Jumper cables with threaded ferrules

To be used in conjunction with any of the clamps described above to make jumper equipment suit most any need both quickly and easily. Cable is IEC-60245 type, either 35 mm² current rating: 200 A or 50 mm² current rating: 250 A, depending on the models. Delivered with screwing ISO M8.



Section: 50 mm²

Section: 35 mm²

MC-153/05	Length: 0.50 m - Weight: 0.270 kg
MC-153/10	Length: 1.00 m - Weight: 0.570 kg
MC-153/30	Length: 3.00 m - Weight: 1.720 kg
MC-153/60	Length: 6.00 m - Weight: 3.460 kg

MC-155/05	Length: 0.5 m - Weight: 0.380 kg
MC-155/10	Length: 1.00 m - Weight: 0.760 kg
MC-155/20	Length: 2.00 m - Weight: 1.520 kg
MC-155/30	Length: 3.00 m - Weight: 2.280 kg
MC-155/60	Length: 6.00 m - Weight: 4.560 kg
MC-155/80	Length: 8.00 m - Weight: 6.080 kg

Overhead lines systems

Consumer units system

Jumper cables

Jumper cable with insulated jumper clamps

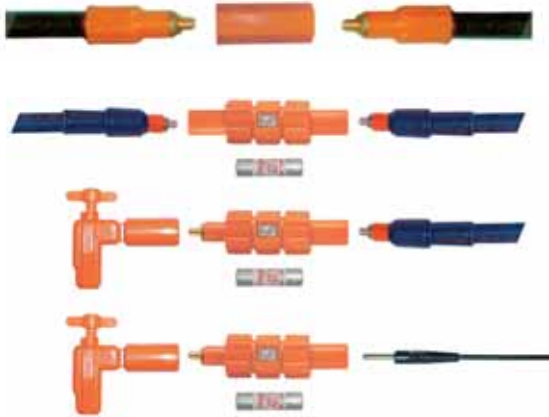

Reference		Size (mm)	Weight (g)
MC-121	Junction for shunt M8	Hexa. 22 L60	0.055
MC-122	Fuse holder for shunt	Ø 35 L125	0.130
MC-123	Fuse holder for shunt	Ø 35 L125	0.140
MC-124	Fuse holder for clamps	Ø 35 L125	0.140

Threaded adapter

Cylindrical body diameter 10 mm to fits on panel network thread. Total length 50 mm.



MC-181

MC-181	4 adapters for short-circuiting - M12 Weight: 0.05 kg
MC-182	4 adapters M8 Width: 50 x 10 mm - Weight: 0.027 kg
MC-183	4 adapters M12 Width: 50 x 17 mm - Weight: 0.048 kg

Tap off box

The tap off box allows on each side to connect 3 by pass jumpers type MC-153/... is delivery equipped with six removable fittings type MC-156/1 and an insulating wrench. This item in conjunction with by pass jumpers allows to shunt a tap off box by means of a second tap off box. Current rating 200 A.



MC-156	40 x 80 x 158 mm
MC-156/1	Spare part
MO-237-D	Triangular spanner with T handle

Jumper cable with insulated jumper clamps

2 clamps MC-120
Spring tightening. Connector for 8 mm cable Ø.
Tightening capacity: 12 mm (diameter - flat).
Rated insulation: 1500 V. Rating 5 (kA/1s).
Continuous rating 75 A. 1 insulated cable 25 mm² section.



Reference	Cable length (m)	Weight (kg)
MC-120/15	1.50	0.850
MC-120/50	5.00	1.950
MC-120/100	10.00	4.000

Shunt Telescopic probe

This probe is completely insulated through the end, and includes a retractable shroud containing a 10 mm diameter copper braided stem that connects to device terminals and network connector boards. The female screw socket allows attachment to shunt cables. Nominal current: up to 250 A.



MC-126	Connector with insulated probe 1.5 to 16 mm In 60 A - 65 x 185 x 29 - 0.130
MC-126/1	Connector with insulated probe 10 to 70 mm In 100 A - 65 x 185 x 29 - 0.166



MC-150	Ø 33 mm L 180 mm - Weight: 0.160 kg
--------	-------------------------------------

Jumper connecting box with fuse

The shunt for collective channeling is a box used to make sure, before proceeding to the replacement of/removing a molten fuse situated on a channeling, that the defect which brought about the molten is eliminated. This box is used with a fuse when the (nominal) assigned intensity of the channeling is < 100 A and with 2 fuses when this intensity is included between 100 A and 200 A. It can also be used to open a circuit in load, for example to change a damaged accessory such as a pin.



MC-116	Shunt for collective channeling from 30 to 200 A
--------	--

Other connecting box: consult us.

ISOMIL™ 2

1000 V
IEC60900 EN60900

The new range of bimaterial insulated tools for live working up to 1000 Volts according to IEC 60900 standard.

Each ISOMIL tool is controlled and tested to 10000 volts. This ensured by strict quality control procedures.

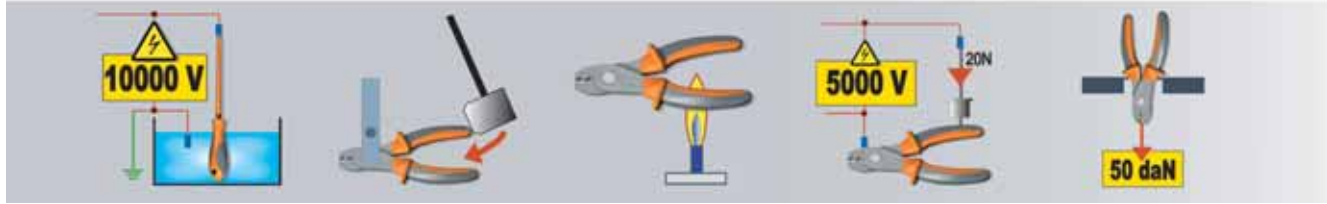

Flat blade screwdrivers

Chrome - molybdenum vanadium steel blade.



Reference	Characteristics	Weight (g)
MO-72003	Blade 3 x 100 mm	40
MO-72004	Blade 3.5 x 100 mm	43
MO-72005	Blade 4 x 100 mm	58
MO-72006	Blade 5.5 x 125 mm	76
MO-72007	Blade 6.5 x 150 mm	112
MO-72009	Blade 8 x 175 mm	171



POZIDRIV screwdrivers

Chrome - molybdenum vanadium steel blade.



Reference	Characteristics	Weight (g)
MO-72040	n°0 head 3 x 60 mm	37
MO-72042	n°1 head 4.5 x 80 mm	58
MO-72044	n°2 head 6 x 100 mm	91
MO-72046	n°3 head 8 x 150 mm	170



Low voltage

Universal plier

Special steel, chrome mat finished.

Reference	Length (mm)	Cutting capacity	Weight (g)
MO-72102	180	For copper and aluminium Ø max (mm): 2.5	255



Bent snipe nose plier

Special steel, chrome mat finished.

Reference	Length (mm)	Cutting capacity	Weight (g)
MO-72142	160	For copper and aluminium Ø max (mm): 2.5	140



Flat nose plier

Special steel, chrome mat finished.

Reference	Length (mm)	Weight (g)
MO-72132	160	140



Round nose plier

Special steel, chrome mat finished.

Reference	Length (mm)	Weight (g)
MO-72122	160	140



Side cutter

Special steel, chrome mat finished.

Reference	Length (mm)	Cutting capacity	Weight (g)
MO-72162	160	For copper and aluminium Ø max (mm): 4.0	212



Cable cutter

Special steel, chrome mat finished.

Reference	Length (mm)	Cutting capacity	Weight (g)
MO-72200	160	For copper and aluminium Ø max (mm): 5.0	238



Wire stripping plier

Special steel, chrome mat finished.

Reference	Length (mm)	Cutting capacity	Weight (g)
MO-72172	160	For copper and aluminium Ø max (mm): 5.0	166



Water pump plier

Special steel.

Reference	Length (mm)	Weight (g)
MO-72155	250	347



Screwdrivers kit

Reference	Composition
KIT-23	MO-72004 Flat blade screwdriver 3.5 x 100 mm
	MO-72006 Flat blade screwdriver 5.5 x 125 mm
	MO-72009 Flat blade screwdriver 8 x 175 mm
	MO-72042 POZIDRIV screwdriver n°1 4.5 x 80 mm
	MO-72044 POZIDRIV screwdriver n°2 6 x 100 mm



Pliers kit

Reference	Composition
KIT-27	MO-72102 Universal plier 180 mm
	MO-72155 Water pump plier 250 mm
	MO-72172 Wire stripping plier 160 mm
	MO-72142 Bent snipe nose plier 160 mm
	MO-72200 Cable cutter 170 mm



Intervention kit

Reference	Composition
KIT-24	MO-72004 Flat blade screwdriver 3.5 x 100 mm
	MO-72006 Flat blade screwdriver 5.5 x 125 mm
	MO-72009 Flat blade screwdriver 8 x 175 mm
	MO-72042 POZIDRIV screwdriver n°1 4.5 x 80 mm
	MO-72044 POZIDRIV screwdriver n°2 6 x 100 mm
	MO-72172 Wire stripping plier 160 mm
	MO-72142 Bent snipe nose plier 160 mm
	MO-72200 Cable cutter 160 mm



Complete intervention kit

Reference	Composition
KIT-25	MO-72004 Flat blade screwdriver 3.5 x 100 mm
	MO-72006 Flat blade screwdriver 5.5 x 125 mm
	MO-72009 Flat blade screwdriver 8 x 175 mm
	MO-72042 POZIDRIV screwdriver n°1 4.5 x 80 mm
	MO-72044 POZIDRIV screwdriver n°2 6 x 100 mm
	MO-72102 Universal plier 180 mm
	MO-72155 Water pump plier 250 mm
	MO-72172 Wire stripping plier 160 mm
	MO-72142 Bent snipe nose plier 160 mm
	MO-72200 Cable cutter 160 mm



Screwdrivers

Pliers

Cutters and pliers

Wrenches, spanners and sockets

Tool sets

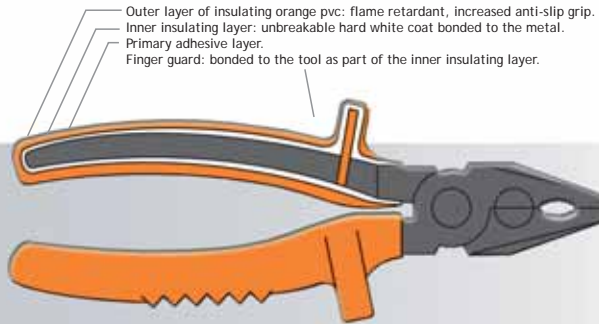

Complete range of insulated tools for live working up to 1000 Volts according to IEC 60900 standard. Each ISOMIL tool is controlled and tested to 10000 volts. This ensured by strict quality control procedures.

Phase tester insulated screwdriver

Phase detection from 127 V A.C.
 Maximum voltage use: 1000 V.
 Signaling by intermittent lighting through ultra high intensity diode.
 Works with an unremovable lithium battery (life time guarantee 3 years).
 Frequency: 50/60 Hz.



CE



Patented

Reference	Characteristics	Weight (g)
MO-65222	Flat blade 4 x 85 mm	65

Flat blade screwdrivers

Chrome - molybdenum vanadium steel blade.



Reference	Characteristics	Weight (g)
MO-65203	Blade 3 x 100 mm	33
MO-65204	Blade 3.5 x 100 mm	37
MO-65205	Blade 4 x 100 mm	46
MO-65206	Blade 5.5 x 125 mm	75
MO-65207	Blade 6.5 x 150 mm	94
MO-65209	Blade 8 x 175 mm	165
MO-65211	Blade 10 x 200 mm	195

POZIDRIV screwdrivers

Chrome - molybdenum vanadium steel blade.



Reference	Characteristics	Weight (g)
MO-65240	n°0 head 3 x 60 mm	25
MO-65242	n°1 head 4.5 x 80 mm	50
MO-65244	n°2 head 6 x 100 mm	75
MO-65246	n°3 head 8 x 150 mm	150
MO-65248	n°4 head 10 x 200 mm	230

PHILLIPS screwdrivers

Chrome - molybdenum vanadium steel blade.



Reference	Characteristics	Weight (g)
MO-65230	n°0 head 3 x 60 mm	25
MO-65232	n°1 head 4.5 x 80 mm	50
MO-65234	n°2 head 6 x 100 mm	75
MO-65236	n°3 head 8 x 150 mm	150
MO-65238	n°4 head 10 x 200 mm	230

Universal pliers

Special steel, oil-hardened. Burnished head.

Reference	Overall length (mm)	Weight (g)
MO-66001	160	210
MO-66002	180	260
MO-66003	200	300
MO-66005*	250	510

* New England style



MO-66005

Flat nose pliers

Special steel, oil-hardened. Burnished head.

Reference	Overall length (mm)	Weight (g)
MO-66300	145	115
MO-66302	160	160



Round nose pliers

Special steel, oil-hardened. Burnished head.

Reference	Overall length (mm)	Weight (g)
MO-66202	160	150



Bent snipe nose pliers

Chrome-vanadium steel. Burnished head.

Reference	Overall length (mm)	Weight (g)
MO-66402	160	160
MO-66404	200	185



Long nose pliers with side cutter

Special steel, oil-hardened. Burnished head.

Reference	Overall length (mm)	Weight (g)
MO-66102	160	145



Plug pliers for preinsulated pin terminals

Chrome-vanadium steel for pin terminals 2.8/5/6.35 mm.

Reference	Overall length (mm)	Weight (g)
MO-66105	200	200



Waterpump pliers

Chrome-vanadium steel. Burnished head.

STANDARD

Reference	Overall length (mm)	Weight (g)
MO-66502	250	410



BOX JOINT PLIERS

Reference	Overall length (mm)	Weight (g)
MO-66505	250	405



Side cutters

Special carbon steel, oil-hardened. Burnished head.

Reference	Overall length (mm)	Cutting capacity (mm)		Weight (g)
		Soft 80 kg/mm ²	Hard 140 kg/mm ²	
MO-67101	140	Ø 2	Ø 1	150
MO-67102	160	Ø 2.5	Ø 1.5	180
MO-67103	180	Ø 3	Ø 2.5	210



End cutting pliers

Special carbon steel, oil-hardened. Burnished head.

Reference	Overall length (mm)	Cutting capacity (mm)		Weight (g)
		Soft 80 kg/mm ²	Hard 140 kg/mm ²	
MO-67401	140	Ø 2	Ø 1	165
MO-67402	160	Ø 3	Ø 2	210
MO-67404	200	Ø 4	Ø 3	450



Cable cutter

Chrome-vanadium forged steel oil-hardened.

Reference	Overall length (mm)	Cutting capacity (mm)	Weight (g)
MO-67500	170	Maximum Ø 4	420



Cable cutters

Chrome-vanadium forged steel oil-hardened.

Reference	Overall length (mm)	Cutting capacity (mm)	Weight (g)
MO-67501	170	Maximum Ø 15	285
MO-67502	230	Maximum Ø 20	520



MO-67501



MO-67502

Ratchet cable cutters

For copper and aluminium cables only. Treated forged steel blade.

Reference	Cutting capacity	Weight (g)
MO-67599	Ø 32 mm/180 mm ² Cu 250 mm ² Al	900
MO-67600	Ø 38 mm/240 mm ² Cu 300 mm ² Al	950
MO-67601	Ø 55 mm/300 mm ² Cu 450 mm ² Al	975



MO-67599



MO-67600

Frontal ratchet cable cutter

For copper and aluminium only. Treated forged steel blade.

Reference	Cutting capacity	Weight (g)
MO-67611	Ø 32 mm 180 mm ² Cu 250 mm ² Al	900



Hacksaw

Protected hard forged steel. Two blade positions. Flush and 90° cutting supplied. Delivered with 2 blades.

Reference	Blade length (mm)	Overall length (mm)	Weight (g)
MO-64502	300	450	780



Screwdrivers

Pliers

Cutters and pliers

Wrenches, spanners and sockets

Tool sets

Stripping pliers for L.V. cables

Aluminium casting plier.
To strip L.V. twisted cables.

Reference	Overall length (mm)	Stripping capacity	Weight (g)
MO-67304	220	from 16 to 150 mm ²	470



Stripping pliers for L.V. cables

Aluminium casting plier. To strip L.V. cables.

Reference	Overall length (mm)	Stripping capacity (mm ²)	Weight (g)
MO-67305	265	From 16 to 150	650
MO-67306	270	From 50 to 240	670



Wire stripping pliers

Chrome vanadium steel. Burnished head.

Reference	Overall length (mm)	Capacity (mm ²)	Weight (g)
MO-67302	160	0.6 to 10	170



Electrician's scissors

Stainless steel blades.
Softgrip handles.
Adjustable screw joint.
Non insulated tool.

Reference	Overall length (mm)	Weight (g)
MO-72100	145	62



Stripping knives

Delivered with pouch.

Reference	Blade length (mm)	Overall length (mm)	Weight (g)
MO-61001	62 (Straight)	190	110
MO-61002	50 (Curve)	190	110



Adjustable spanner

Special steel, oil-hardened.

Reference	Overall length (mm)	Maximum capacity (mm)	Weight (g)
MO-69002	210	24	295
MO-69003	250	28	450
MO-69004	310	34	550
MO-69005	385	43	1350



Reversible hexagonal ratchet handle

Special steel, oil-hardened.

Reference	Size (mm)	Weight (g)
MO-69210	10	160
MO-69213	13	190
MO-69216	16	350
MO-69217	17	370
MO-69218	18	380
MO-69219	19	390



Combination wrench

Special steel sockets.

Reference	4 hexagonal sockets	Weight (g)
MO-68701	6-8-10-12 mm/150 x 150 mm	225
MO-68702	8-10-12-14 mm/150 x 150 mm	260
MO-68703	7-9-11-13 mm/150 x 150 mm	250
MO-68704	8-10-13-17 mm/150 x 150 mm	260



Right angle hexagonal key wrench

Chrome-vanadium steel.

Reference	Hexagonal head	Weight (g)
MO-69903	3 mm/83 x 123 mm	30
MO-69904	4 mm/84 x 124 mm	40
MO-69905	5 mm/84 x 126 mm	50
MO-69906	6 mm/85 x 126 mm	70
MO-69908	8 mm/87 x 128 mm	110
MO-69910	10 mm/87 x 130 mm	150
MO-69912	12 mm/90 x 132 mm	240



Open end spanners

Chrome-vanadium steel.

Reference	Size (mm)	Weight (g)	Reference	Size (mm)	Weight (g)
MO-68008	8	40	MO-68020	20	185
MO-68009	9	40	MO-68021	21	200
MO-68010	10	45	MO-68022	22	220
MO-68011	11	50	MO-68023	23	250
MO-68012	12	60	MO-68024	24	260
MO-68013	13	80	MO-68025	25	280
MO-68014	14	100	MO-68026	26	300
MO-68015	15	110	MO-68027	27	340
MO-68016	16	120	MO-68028	28	360
MO-68017	17	140	MO-68029	29	400
MO-68018	18	160	MO-68030	30	500
MO-68019	19	170	MO-68032	32	570

Reference	Characteristics	Weight (g)
MO-68008/19	8 open end spanners set 8/10/11/12/13/ 14/17/19 mm	685



Cranked ring wrench

Chrome-vanadium steel.

Reference	Size (mm)	Weight (g)	Reference	Size (mm)	Weight (g)
MO-68107	7	35	MO-68120	20	240
MO-68108	8	40	MO-68121	21	260
MO-68109	9	45	MO-68122	22	260
MO-68110	10	50	MO-68123	23	270
MO-68111	11	65	MO-68124	24	280
MO-68112	12	80	MO-68125	25	300
MO-68113	13	100	MO-68126	26	360
MO-68114	14	120	MO-68127	27	400
MO-68115	15	150	MO-68128	28	440
MO-68116	16	180	MO-68129	29	480
MO-68117	17	190	MO-68130	30	500
MO-68118	18	195	MO-68132	32	540
MO-68119	19	200			



Hexagonal spanner with T handle

Chrome steel. length 130 mm

Reference	Size (mm)	Weight (g)
MO-68610	10	145
MO-68613	13	185
MO-68614	14	220



Sockets wrench sets

Chrome steel.



MO-69524

MO-69308/23

MO-69543

Sockets 3/8" (9.53 mm)-6 sided

Reference	Characteristics (mm)	Weight (g)
MO-69306	Socket 6	25
MO-69307	Socket 7	30
MO-69308*	Socket 8	30
MO-69309	Socket 9	30
MO-69310*	Socket 10	35
MO-69311	Socket 11	35
MO-69312*	Socket 12	35
MO-69313*	Socket 13	45
MO-69314*	Socket 14	45
MO-69315	Socket 15	50
MO-69316	Socket 16	55
MO-69317*	Socket 17	60
MO-69318	Socket 18	65
MO-69319*	Socket 19	70
MO-69321*	Socket 21	85
MO-69322*	Socket 22	90
MO-69323*	Socket 23	100
MO-69513*	Reversible ratchet	600
MO-69523*	Extension 130	124
MO-69533	Extension 250	270
MO-69542	T wrench 130	220
MO-69543	T wrench 200	380
MO-69308/23	complete sockets set in plastic box 410 x 120 x 75	1250

Sockets 1/2" (12.7 mm)-12 sided

Reference	Characteristics (mm)	Weight (g)
MO-69408*	Socket 8	60
MO-69410*	Socket 10	60
MO-69411	Socket 11	60
MO-69412*	Socket 12	70
MO-69413*	Socket 13	70
MO-69414*	Socket 14	70
MO-69415	Socket 15	75
MO-69416	Socket 16	75
MO-69417	Socket 17	80
MO-69418	Socket 18	80
MO-69419*	Socket 19	85
MO-69420	Socket 20	90
MO-69421*	Socket 21	100
MO-69422*	Socket 22	100
MO-69423*	Socket 23	115
MO-69424	Socket 24	130
MO-69430	Socket 30	160
MO-69514*	Reversible ratchet	600
MO-69524*	Extension 125	250
MO-69534	Extension 250	435
MO-69544	T wrench 300	520
MO-69408/23	complete sockets set in plastic box 410 x 120 x 75	1500

* Sockets composing the sets

* Sockets composing the sets

Screwdrivers

Pliers

Cutters and pliers

Wrenches, spanners
and sockets

Tool sets

Special sockets wrench sets

Chrome steel.



Reference	Characteristics (mm)	Weight (g)
MO-69813	Socket 13 mm - 1/4"	45
MO-69317	Socket 17 mm - 3/8"	60
MO-69840	Extension 1/4" x 3/8"	60
MO-69512	Reversible ratchet - 1/4"	200
MO-69813/17	Complete sockets set in plastic box 230 x 170 x 45	365

Reference	Characteristics (mm)	Weight (g)
MO-69810	Socket 10 mm - 1/4"	35
MO-69813	Socket 13 mm - 1/4"	45
MO-69317	Socket 17 mm - 3/8"	60
MO-69840	Extension 1/4" x 3/8"	60
MO-69512	Reversible ratchet - 1/4"	200
MO-69810/17	Complete sockets set in plastic box 230 x 170 x 45	500

Sockets 3/8" Long series

65 mm length. Chrome steel.



Reference	Socket (mm)	Weight (g)
MO-69610	10	75
MO-69613	13	80
MO-69614	14	100
MO-69616	16	115
MO-69617	17	125
MO-69618	18	140
MO-69619	19	160
MO-69621	21	190

Sockets 3/8" U.S Standard

Chrome steel.



Reference	Socket	Weight (g)
MO-69735	3/8"	25
MO-69736	7/16"	30
MO-69737	1/2"	35
MO-69738	9/16"	35
MO-69739	5/8"	42
MO-69740	11/16"	50
MO-69741	3/4"	55
MO-69742	13/16"	60

6 sided male hex Key / Socket 3/8"

Steel.



Reference	Socket (mm)	Weight (g)
MO-69393	3	45
MO-69394	4	55
MO-69395	5	60
MO-69396	6	65
MO-69397	7	70
MO-69398	8	70
MO-693100	10	80

Insulated torque wrench 3/8"

Capacity: 8 to 54 Nm (ibF Ft: 5-40).

Linear graduation, english and french scales (ibF Ft and Nm).

Length: 325 mm.

Tolerance: 4%.



Reference	Characteristics	Weight (g)
MO-69050	8 to 54 Nm	790

Tool bag

For intervention works, strong waterproof, canvas reinforced bottom, large capacity of storage, shoulder strap.



Reference	Characteristics	Weight (Kg)
M-87370	440 x 330 x 160 mm	1 100

Tool bag

Black grained leather with handle. The interior includes: a pocket, a separation which forms a tool tray and a fold-down tool tray.



Reference	Characteristics	Weight (Kg)
MO-34	410 x 280 x 150 mm	3 200

Insulated tool kits

For the most common operations, CATU proposes 4 kits of ISOMIL handtools.

Reference	Composition
KIT-03	MO-65242 Pozidriv screwdriver* N°1 4.5 x 80 mm
	MO-65244 Pozidriv screwdriver N°2 6 x 100 mm
	MO-65204 Flat blade screwdriver 3.5 x 100 mm
	MO-65206 Flat blade screwdriver 5.5 x 125 mm
	MO-65209 Flat blade screwdriver 8 x 175 mm

Reference	Composition
KIT-07	MO-66002 Universal pliers overall length 180 mm
	MO-66502 Water pump pliers overall length 250 mm
	MO-67302 End stripping pliers overall length 160 mm
	MO-66402 Bent snipe nose pliers overall length 160 mm
	MO-67500 Cable cutter overhall length 170 mm

Reference	Composition
KIT-04	MO-65242 Pozidriv screwdriver* N°1 4.5 x 80 mm
	MO-65244 Pozidriv screwdriver N°2 6 x 100 mm
	MO-65204 Flat blade screwdriver 3.5 x 100 mm
	MO-65206 Flat blade screwdriver 5.5 x 125 mm
	MO-65209 Flat blade screwdriver 8 x 175 mm
	MO-67302 End stripping pliers overall length 160 mm
	MO-66402 Bent snipe nose pliers overall length 160 mm
MO-67500 Cable cutter overhall length 170 mm	

Reference	Composition
KIT-05	MO-65242 Pozidriv screwdriver* N°1 4.5 x 80 mm
	MO-65244 Pozidriv screwdriver N°2 6 x 100 mm
	MO-65204 Flat blade screwdriver 3.5 x 100 mm
	MO-65206 Flat blade screwdriver 5.5 x 125 mm
	MO-65209 Flat blade screwdriver 8 x 175 mm
	MO-66002 Universal pliers overall length 180 mm
	MO-66502 Water pump pliers overall length 250 mm
	MO-67302 End stripping pliers overall length 160 mm
	MO-66402 Bent snipe nose pliers overall length 160 mm
	MO-67500 Cable cutter overhall length 170 mm



Low voltage complete set

Complete equipment for live line (L.V.) interventions.



MO-510-03-EX	Tool bag not included (MO-34)	
Personal equipment		
MO-11001	1 safety glasses	MO-69903 1 right angle hexagonal key wrench 3 mm
CG-98	1 working gloves	MO-69904 1 right angle hexagonal key wrench 4 mm
Voltage detector		
MS-911-EX	1 voltage multitester	MO-69906 1 right angle hexagonal key wrench 6 mm
Insulating		
CG-05-B	1 rubber gloves size B	MO-751 1 insulating folding rule
CG-36	1 carrying bag for rubber gloves	MO-69003 1 adjustable spanner 250 mm
MP-42/16	1 insulating mat	MO-66002 1 universal pliers 180 mm
MP-26-A	10 insulating caps	MO-66202 1 round nose pliers 160 mm
MP-35/12	1 insulating blanket	MO-66502 1 water pump pliers 250 mm
MP-39	10 wood clamps for insulating blanket	MO-67102 1 side cutter 160 mm
MP-32/15	6 line protectors	MO-69308/23 1 sockets 3/8" wrench set with 10 sockets: 8, 10, 12, 13, 14, 17, 19, 21, 22, 23
MP-19	5 insulated adhesive tapes	MO-65205 1 flat blade screwdriver 4 x 100
Insulated tools		
MO-61001	1 stripping knife	MO-65207 1 flat blade screwdriver 6,5 x 150
MO-67502	1 cable cutter 230 mm	MO-65209 1 flat blade screwdriver 8 x 175
MO-68008/19	1 open end spanners set with 8, 10, 11, 12, 13, 14, 17, 19 mm open end spanners	MO-65232 1 Phillips screwdriver n° 1
		MO-65234 1 Phillips screwdriver n° 2
		MO-65236 1 Phillips screwdriver n° 3

Intervention kit for electricians

MO-38510	Composition:	
M-87370	1 Tool bag	MO-65244 Pozidriv screwdriver N°2 6 x 100 mm
CG-05-C	1 Pair of insulated gloves	MO-66002 Universal pliers overall length 180 mm
MO-11001	1 Safety glasses	MO-66502 Water pump pliers overall length 250 mm
AL-230	1 Safety padlock	MO-67302 End stripping pliers overall length 160 mm
MO-65204	Flat blade screwdriver 3.5 x 100 mm	MO-66402 Bent snipe nose pliers overall length 160 mm
MO-65206	Flat blade screwdriver 5.5 x 125 mm	MO-67500 Cable cutter overall length 170 mm
MO-65209	Flat blade screwdriver 8 x 175 mm	
MO-65242	Pozidriv screwdriver* N°1 4.5 x 80 mm	



The world

of electrical safety



OIL & GAS

Offshore installations, shipbuilding, heavy industry



Your major supplier for
all your electrical safety equipment needs



Just contact us !

CATUTM

Medium voltage



From 1kV to 52kV

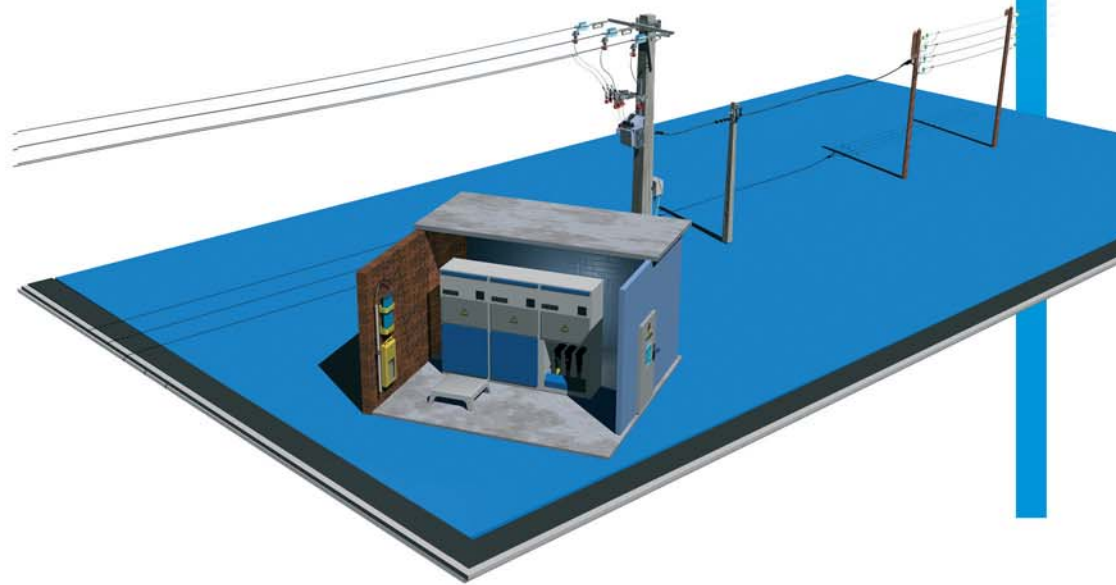

Equipment guide	54
Personal protective equipment	58
Substation equipment	67
Voltage detectors	79
Short-circuiting and earthing systems	84
General tools	91
Earth rods	96

Examples of usual applications

Overhead line work from pole

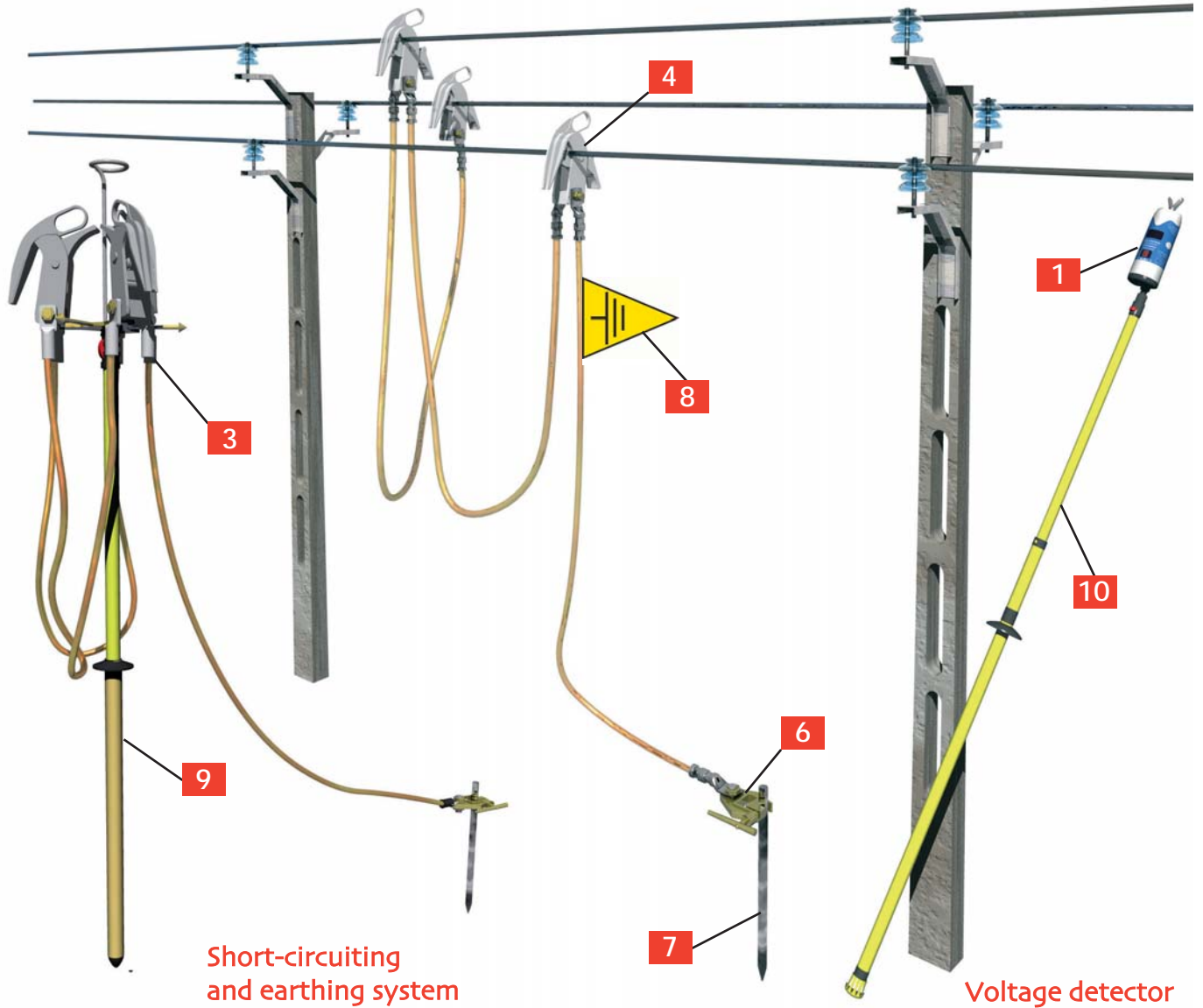

Voltage detectors and phase comparators

1	Electronic voltage detectors IEC or standard	References: CC-875 serie	Page: 79
2	Single pole phase comparator	Reference: CL-7 serie	Page: 83

Short-circuiting Systems

3	IEC short-circuiting and earthing systems: Three-phase crossarm networks (work from pole)	References: MT-6613 serie	Page: 85
4	Clamps and spare parts		Page: 86
5	Short-circuiting and earthing systems: Mid-span horizontal configurations (Work from ground)	References: MT-512/.. serie	Page: 87

APPLICATIONS

Before intervention select the right personal protective equipment

Overhead line work from ground

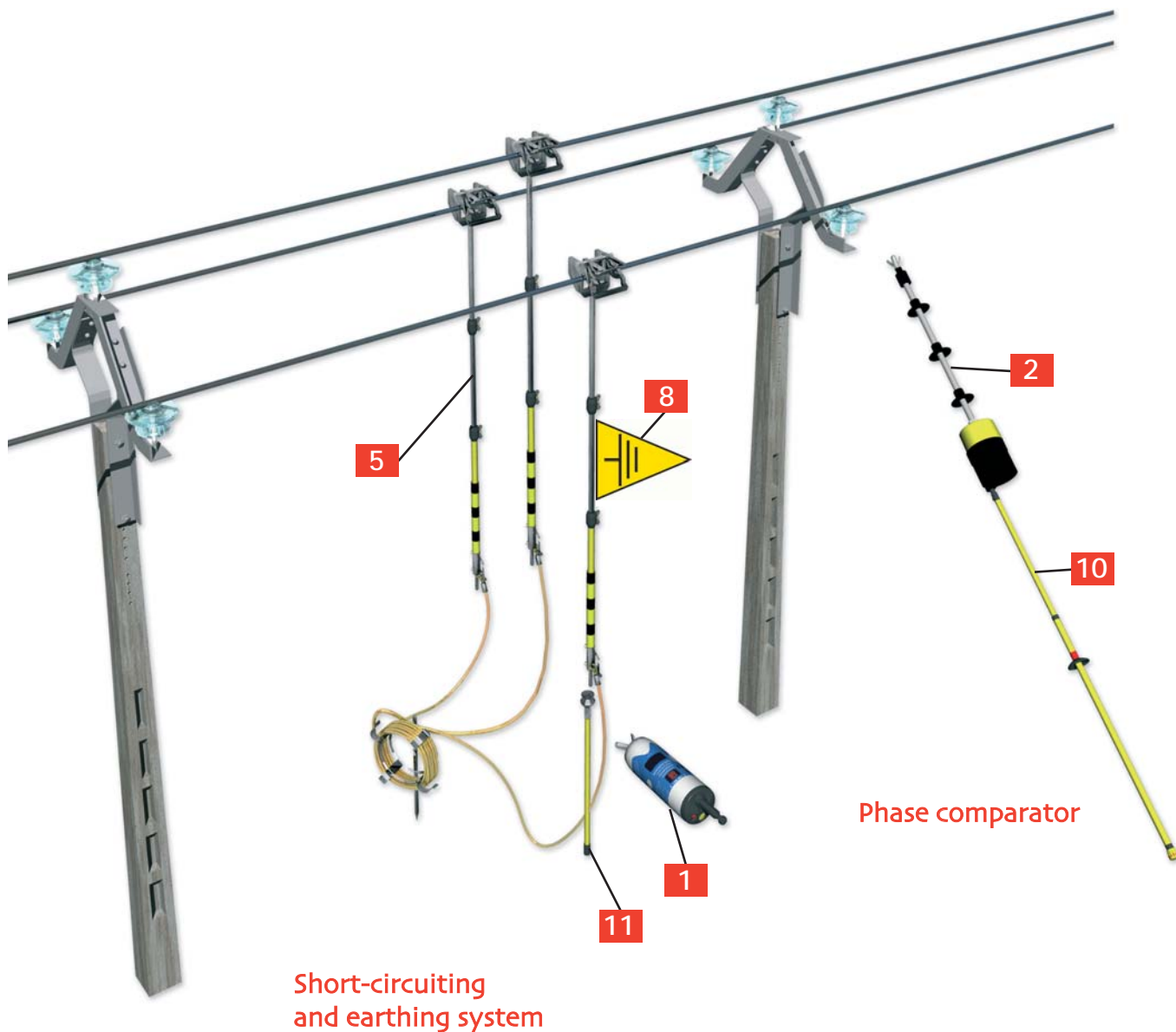

Short-circuiting and earthing system

Phase comparator

Medium voltage

Earth Clamps, rod and flags

6	Earth Clamps	References: MT-840/1, MT-843	Page: 86
7	Earth rods	References: MT-650, MT-652/2	Page: 86
8	Earth Flags	References: AL-58, AL-60	Page: 70

Insulating sticks

9	Insulating Sticks IEC For short-circuiting systems and Voltage detectors	References: CM-4, CM-7, CM-4000	Pages: 88
10	Insulating sticks IEC for voltage detectors	References: CE-4-21, CE-75	Page: 81
11	Insulating sticks for short circuiting system MT-512	Reference: MT-531	Page: 87

Examples of usual applications

Substation with Bare conductors

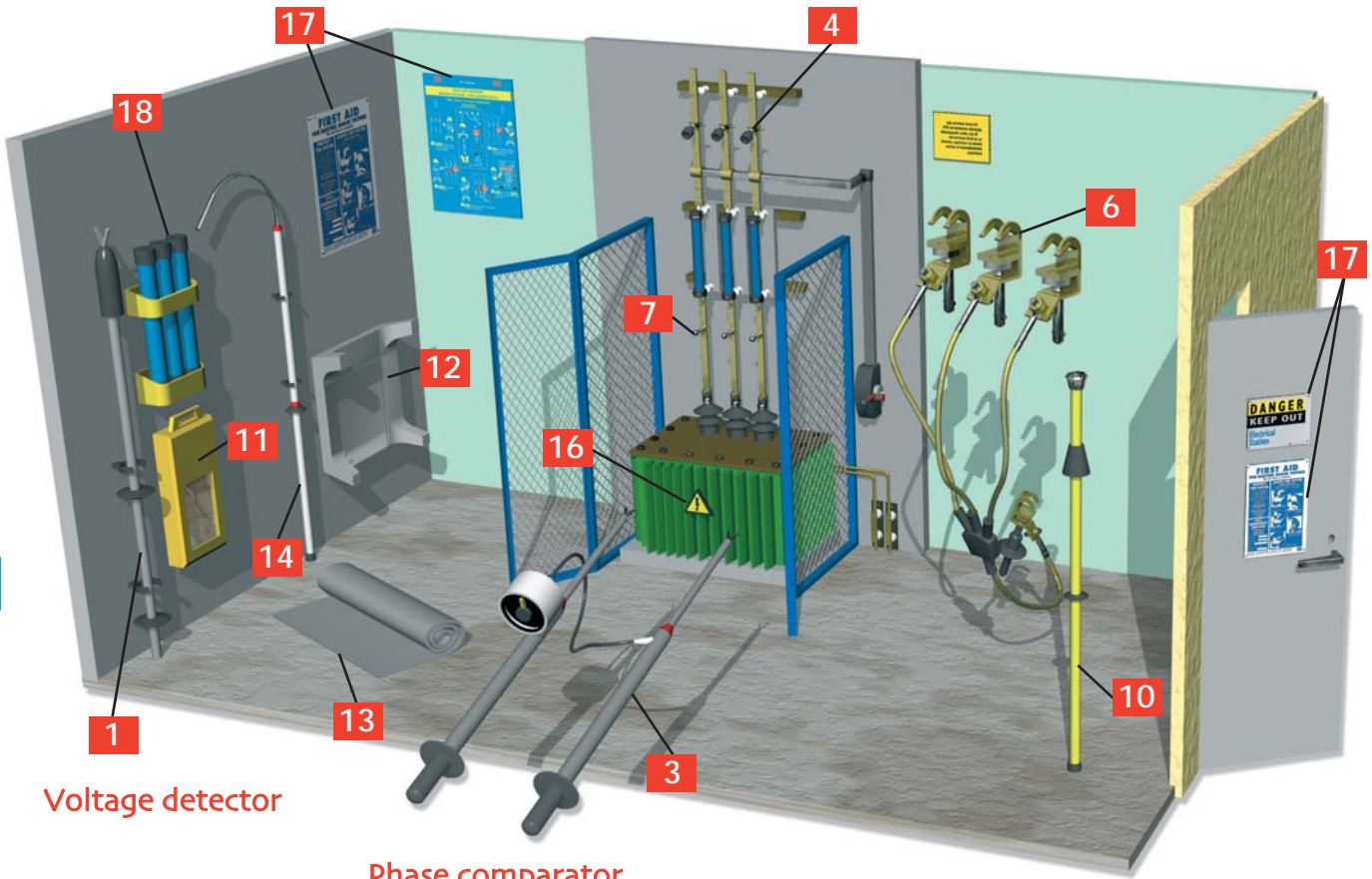

Voltage detector

Phase comparator

Short-circuiting and earthing system

Voltage detectors and phase comparators

1	Voltage detectors for indoor use 5-40 kV	References: CL-4, CL-2 series	Page: 76
2	Voltage detector for separable connectors	Reference: CC-151-K	Page: 76
3	Phase comparators two poles or single pole	References: CL-5, CL-8, CL-7 series	Pages: 82/83
4	Permanent luminous indicator	Reference: CL-40010	Page: 76
5	Integrated systems VIS VDS	References: CL-495, CL497, CL-498	Page: 77

Short-circuiting Systems

6	Short-circuiting system for MV substations: For installation on permanent fixed points For installation on bare conductors	References: MT-1910/MT-1920 References: MT-5805/MT-9801	Page: 72 Page: 72
7	Fixed points	References: MT-2950/MT-3950 series	Page: 72
8	Short-circuiting system for switchgear: For 250 A separables connectors For 400 A separables connectors	Reference: MT-8612 Reference: MT-8614	Page: 75 Page: 75

Before intervention select the right personal protective equipment

Substation with switchgear and metalclad switchgear

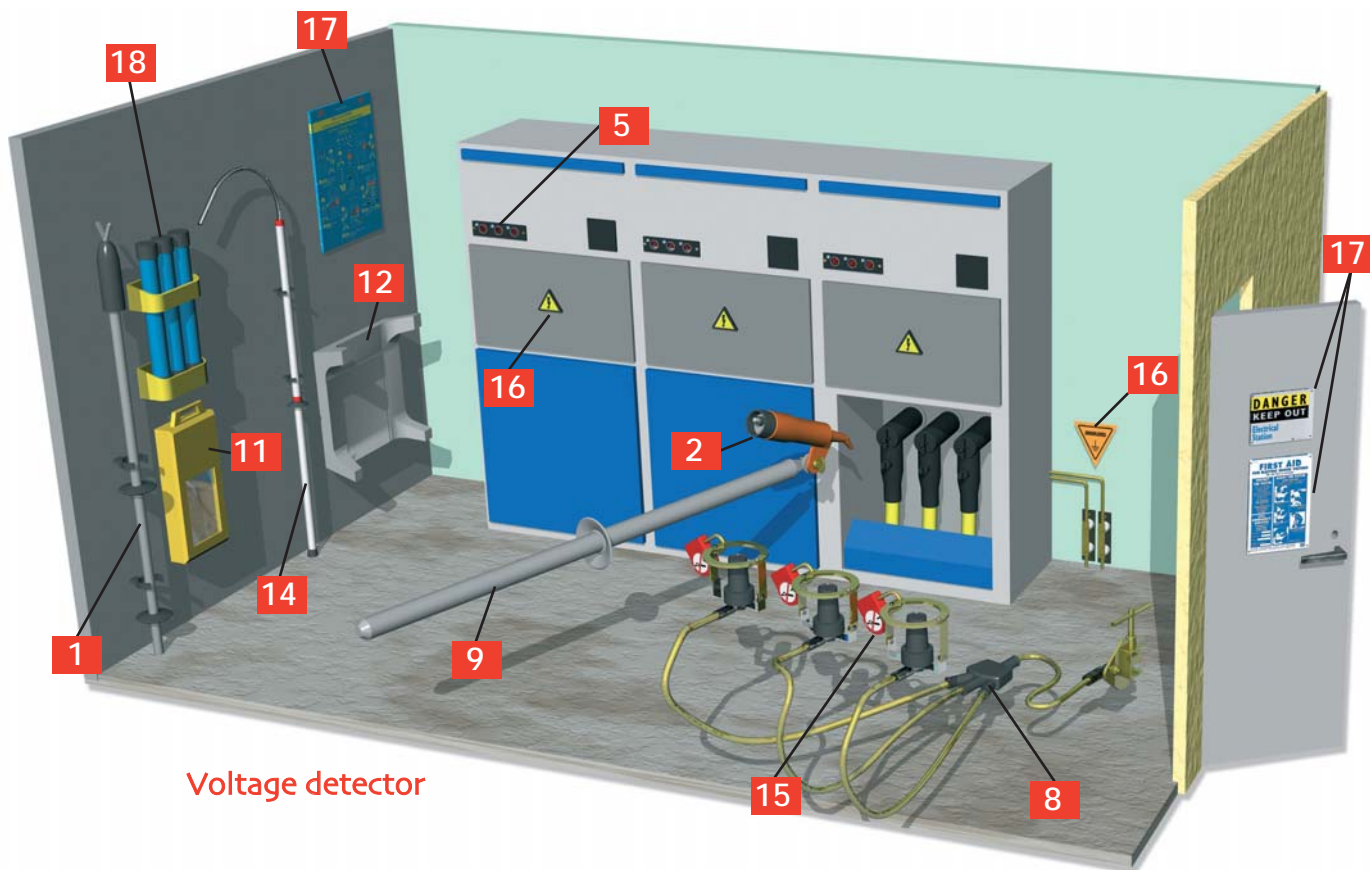

Voltage detector

Short-circuiting and earthing system

Insulating sticks

9	Insulating stick for CC-151-K voltage detector	Reference: CC-45-K	Page: 76
10	Insulating sticks for substations use IEC-61235	References: CF-5-40/CE-4-21...	Page: 81

Protective equipment

11	Insulating rubber gloves 26500 V with storage box	References: CG-30/CG-35/1	Page: 60
12	Insulating Platform 24000 V	Reference: CT-7-25/1	Page: 61
13	Insulating mat 26.5 kV	Reference: MP-42/11	Page: 61
14	Rescue stick 45 kV	Reference: CS-45	Page: 71

Warning signs and accessories

15	Safety padlock	Reference: AL-230/..	Page: 67
16	Warning signs in aluminium	References: AM-49/1, AM-344-GB	Page: 69
17	Specialised signs	References: AP-510-GB/AM-20-GB	Page: 69
18	Fuse holder	Reference: CI-23	Page: 71

Head and eyes protection

Insulating rubber gloves

Insulating mats and platforms

Arc flash equipment

Equipment for working on pole

Safety glasses

Protection against UV radiation and ejections of solid particles. Grilamid frame in orange Softflex. Anti-scratch, anti-impact and anti-chemical product treatments. Caution: Do not use for welding operations.

EN 166/EN 170
CE



MO-11000 Clear lenses, delivered in pouch

MO-11001 Tinted lenses, delivered in pouch

Overglasses

Polycarbonate overglasses. Protection against UV radiation and ejections of solid particles. Caution: Do not use for welding operations.

EN 166/EN 170
CE



MO-11010 Clear lenses

MO-11011 Green tinted lenses

ABS helmet

Electrically insulating helmets for use on voltage installations. Safety industrial helmet, safety helmet for electrical use, especially designed to maximize wearer's comfort. Standard sizes 53 to 63. Leather trim 21 cm along the inside for added comfort. Multiple adjustments for a perfect fit - headband: adjustable in 3 mm increments. Built-in cushion for optimum ventilation. Safety chin strap: fastenings to shell tear resistant. Weight: 0.300 kg.

EN 397
EN 50365
ANSI Z89.1:2003
Class E 20 kV
CE



MO-182/1-B White

MO-182/1-R Red

Polycarbonate helmet

Polycarbonate helmet. Shock and wear resisting, comfortable. Adjustable size from 53 to 63 cm. Weight: 0,465 Kg.

EN 397
CE



MO-183-BL White, single size, adjustable

MO-183-RL Red, single size, adjustable

Face shield

Face shield adjustable on MO -182 helmet. 100% UV protection. Weight: 0.170 kg. Caution: Do not use for welding operations.

EN 166/EN 170
CE



MO-184 Single size, adjustable by rubber band

Helmet with built-in face shield

Panoramic face shield in non-scratch and anti-mist polycarbonate. Chinstrap (with Velcro fastening) Head fit adjustment by milled wheel. Single size: 0.270 kg.

EN 166/EN 170/EN 397
EN 50365
CE



MO-185-BL White

MO-185-R Red

MO-185-J Yellow

MO-185-B Blue

M-881622 Spare face shield for MO-185

Head and eyes protection

Insulating rubber gloves

Insulating mats and platforms

Arc flash equipment

Equipment for working on pole

Bag for helmet and face shield

Cloth cover for transport and protection of helmets and face shields
MO-182, MO-183, MO-184, MO-185-BL, MO-186.



M-87384

Black colour

Headlamp with adjustable focus

Can be carried either on the head or any type of helmet. **CE**
Lighting control and beam by switches.
Range: 30 meters.
Adjustable lamp height angle.
Sealed against rain.
Powered by 4 batteries LR 6.
Autonomy: 6 hours.
Standard bulb 4.8 V/0.3 A.



MS-118

Headlamp - Weight: 0.187 kg

M-95-865

Halogen bulb (sold by set of 5 units)
5.2 V 0.5 A

M-95-864

Hooks set for helmet

LED's Headlamp (3 LED's)

Can be carried either on the head or any kind of helmet. **CE**
- Lighting by 3 high performance LEDs.
- 3 lighting levels.
- Adjustable lamp height angle.
- Very light, waterproof IP65.
- Range: 10 to 15 meters.
- Powered by 3 batteries LR03 (AAA).
- Autonomy: 80 hours.



MS-121

Delivered with batteries and a carrying bag
Weight: 0.09 Kg

M-95-864

Hooks set for helmet

LED's headlamp (5 LED's)

LED's Headlamp (5 LED's). **CE**
Can be carried on the head or any kind of helmet.
Lighting by 5 high performance white new generation LED's - 3 lighting levels + 1 flash mode + 1 red lighting.
IPX6.
Powered by four batteries LR06 (AA).
Range : 30 meters.
Autonomy : 100 hours.



MS-127

Delivered with batteries and a carrying bag
Weight: 226 g

M-95-864

Hooks set for helmet

Intrinsically safe ATEX LED's Headlamp

Ex II 2GD EEx ia IIC T4 **CE**
Can be carried either on the head or any kind of helmet.
- Lighting by 3 high performance White LEDs.
- 2 lighting levels (High: 3 LEDs on or low: 1 LED on).
- Adjustable lamp height angle.
- Very light, ABS body.
- ATEX certified Categorie 2 (Zone 1)
N° TRL03ATEX21005X.
- Range: 10 to 15 meters.
- Powered by 3 batteries LR03 (AAA).
- Autonomy: 150 hours.
- Strap: cloth or silicone rubber (for helmet).



MS-126

Delivered with batteries - Weight: 0,125Kg

M-95-864

Hooks set for helmet

Insulating rubber gloves

Insulating rubber gloves conform to international IEC-60903 standard. To satisfy the requirements of this standard, they are subjected to dielectrical, mechanical resistance and ageing tests. The acceptance levels for mechanical tests are stricter. The tests are especially aimed at checking the tensile strength and elongation at break, the mechanical puncture test and tension set. Our gloves are made of latex especially treated to obtain high dielectric characteristics; they are individually tested and delivered in sealed plastic bags.



IEC-60903
CE

Reference	Class	Voltage (V)	Thickness (mm)	Designation	Weight (g)
CG-15 (*)	1	7500	1.5	latex	270
CG-20 (*)	2	17000	2.3	latex	450
CG-20 (*)-AM	2	17 000	2	Two colors latex rolled edge	450
CG-30 (*)	3	26500	2.9	latex	560
CG-30 (*)-AM	3	26500	2.7	Two colors latex rolled edge	560

* References to be completed by size A, B, C, D
Correspondence with standard sizes: A = 8, B = 9, C = 10, D = 11

Pneumatic glove tester

For compulsory control of gloves before use. Checking is done by inflating and immersing in water.



CG-117 140 x 150 x 160 mm - Weight: 0.600 kg

Rubber gloves storage box with window

To be placed in high voltage stations. Insulating material, shock resistant, yellow colour. Transparent window (enables to check gloves presence). Bottle of talc included. Attachment: 4 holes 3.5 mm dia., centre distances 155 x 345 mm. U.V. protection window.



CG-35/1 60 x 210 x 460 mm - Weight: 0.730 kg

Overgloves

Used as outer glove. Silicon grain leather, very flexible. Large protective cuff in chrome tanned hide. Adhesive strap.



EN 388
CE

CG-99 (*) Weight: 0.170 kg * Add size: C, D

Undergloves

Cotton undergloves To be used with insulating rubber gloves.



CE

CG-80 ()** ** H: men / F: women

Carrying bag

Made from reinforced waterproof fabric for transport of rubber gloves in vehicles and tool boxes. Rear loop for belt and snaps.



CG-36 60 x 180 x 400 mm - Weight: 0.120 kg

Head and eyes protection

Insulating rubber gloves

Insulating mats and platforms

Arc flash equipment

Equipment for working on pole

Working gloves

Handling leather and cotton gloves. Docker type.



EN 388
CE

CG-97-C

Single size (C = 10)

Insulating boots

Made from elastomer canvas support, very flexible and resistant. Anti-perforation stainless steel sole and shell. Anti-slip sole. Protection against step and touch hazardous potential gradients.



EN 345

MV-135*

60 x 210 x 460 mm - Weight: 0.730 kg

* Add sizes: 39-40/41-42-43/44-45-46/47.

Insulating platform (indoor models)

Moulded insulating material, one-piece. Top 50 x 50 cm.



Reference	Rated insulation (V)	Height (mm)	Weight (kg)
CT-7-25/1	24000	220	3.7
CT-7-40/1	40000	260	3.8

Insulating platform (outdoor models)

Solid plate with moulded insulating material 52 x 52 cm, thickness 40 cm. Feet with rubber tips.



Reference	Rated insulation (V)	Number of skirts per foot	Height (mm)	Weight (kg)
CT-9-25	24000	2	350	6.00
CT-9-45	45000	3	435	6.50

Insulating mats

The matting is manufactured of elastomer compounds with slip-resistant surface. High quality dielectrical rubber.

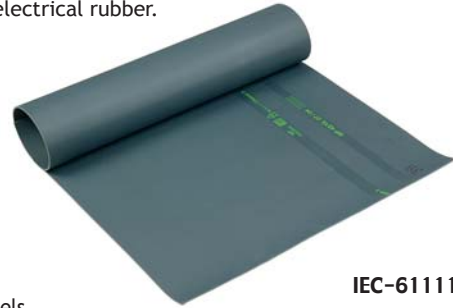

IEC-61111 

Individual models.

Reference	Thickness (mm)	Class	Network Voltage (kV)	Dimensions (m)
MP-42/11	3	3	≤ 26.5	1 x 1
MP-42/16	3	3	≤ 26.5	0.6 x 1
MP-42/66	3	3	≤ 26.5	0.6 x 0.6

For placing in front of panels.

Reference	Thickness (mm)	Class	Network Voltage (kV)	Dimensions (m)
MP-60/03-5	3	3	≤ 26.5	0.6 x 5
MP-60/03-10	3	3	≤ 26.5	0.6 x 10
MP-100/03-5	3	3	≤ 26.5	1 x 5
MP-100/03-10	3	3	≤ 26.5	1 x 10
MP-60/05-5	5	4	≤ 36	0.6 x 5
MP-60/05-10	5	4	≤ 36	0.6 x 10
MP-100/05-5	5	4	≤ 36	1 x 5
MP-100/05-10	5	4	≤ 36	1 x 10

Bags for insulating mats

Specially designed for carrying and protecting insulating mats. Equipped with a shoulder strap and a plastic window for instructions and storage identification.



MP-01

For MP-42/16 and MP-42/66 - Length: 70 cm

MP-02

For MP-42/11 - Length: 110 cm

Multi-pockets electrician bag

Specially designed for carrying and protecting insulating mats, face shield and controllers. Equipped with several pockets.



M-87386

65 x 15 x 25 cm

Head and eyes protection

Insulating rubber gloves

Insulating mats and platforms

Arc flash equipment

Equipment for working on pole

In many countries regulations have been established to protect workers from electrical shock and flash hazards in specific areas within which arc flash protection is required. These equipment must be used with insulating gloves and leather overgloves. Equipment up to 100 cal/cm² on request.

Arc flash face shield kit (10cal/cm²)

Composition of the kit:

- 1 Face shield with chin cup 10cal/cm², absorbs > 99.9% of harmful UV radiation, 70% light transmission, tested to ASTM F2178 specifications
- 1 ABS helmet electrically insulated EN397, EN 50365, ANSI Z89.1, 20kV.
- 1 carrying bag for face shield and helmet



KIT-ARC-01

Weight: 2.1 kg

Arc flash jacket kit (11cal/cm²)

Composition of the kit:

- 1 Face shield with chin cup 10cal/cm², absorbs > 99.9% of harmful UV radiation, tested to ASTM F2178 specifications
- 1 ABS helmet electrically insulated EN397, EN 50365, ANSI Z89.1, 20kV.
- 1 safety glasses EN 166/EN 170
- 1 arc flash protective jacket 11cal/cm² (size L*), ASTM F1506 and NFPA 70E Standards
- 1 carrying bag for face shield and helmet
- 1 all kit carrying bag



KIT-ARC-02

Weight: 4.15 kg

Arc flash protective coverall kit (11cal/cm²)

Composition of the kit:

- 1 Face shield with chin cup 11cal/cm², absorbs > 99.9% of harmful UV radiation, tested to ASTM F2178 specifications
- 1 ABS helmet electrically insulated EN397, EN 50365, ANSI Z89.1, 20kV.
- 1 safety glasses EN 166/EN 170
- 1 arc flash protective Hood (15 cal/cm²)
- 1 protective coverall 11cal/cm² (size L*), ASTM F1506 and NFPA 70E Standards
- 1 carrying bag for face shield and helmet
- 1 all kit carrying bag



KIT-ARC-03

Weight: 4.03 kg

Arc flash protective hood kit (40cal/cm²)

Composition of the kit:

- 1 arc flash protective hood with an integrated face shield 40cal/cm², ASTM F2178 and NFPA 70E Standards
- 1 arc flash protective coat 40cal/cm², (size L*), ASTM F1506 and NFPA 70E Standards
- 1 arc flash protective bib overall 40cal/cm², (size L*), ASTM F1506 and NFPA 70E Standards
- 1 ABS helmet electrically insulated EN397, EN 50365, ANSI Z89.1, 20kV.
- 1 safety glasses EN 166/EN 170
- 1 carrying bag for face shield and helmet
- 1 all kit carrying bag



KIT-ARC-04

Weight: 6.7 kg

* Size US: L
Other size on request.

Head and eyes protection

Insulating rubber gloves

Insulating mats and platforms

Arc flash equipment

Equipment for working on pole

Pro electric full body fall arrest harness

2 fall arrest attachment point: dorsal and sternal. Automatic buckles of the belt and leg loops. Elastic shoulder straps. Padded leg loops. A work positioning belt, with a comfortable and lightweight pad. 2 buckles of work positioning Belt. Leg loops and shoulder straps adjustable. Polyamide straps. Tools holders. 3 sizes : S, M, XL. Delivered in a protective bag with a users manual. Weight: 2.7 kg.



EN 358
EN 361
CE

MO-563(*)

* add size: S/M/XL
S = small M = medium XL = large

Pro electric full body fall arrest harness

4 fall arrest attachment point : one dorsal point, two sternal points by two metallic D rings, a sternal point by strap. A ventral attachment point for a descender and / or lanyard. Automatic buckles of leg loops. Padded leg loops. A work positioning belt, with a comfortable and lightweight pad. 2 buckles of work positioning Belt. Leg loops and shoulder straps adjustable. Polyamide straps. Tools holders. 3 sizes : S, M, XL. Delivered in a protective bag with a users manual. Weight: 2.9 kg.



EN 358
EN 361
EN 813
CE

MO-564(*)

* add size: S/M/XL
S = small M = medium XL = large

Full body fall arrest harness

2 fall arrest attachment point : dorsal and sternal. A work positioning belt, with a comfortable and lightweight pad. 2 buckles of work positioning Belt. Leg loops and shoulder straps adjustable. Polyamide straps. Unique size. Delivered in a protective bag.



EN 358
EN 361
CE

MO-71

Weight: 1.9 kg

Equipped rope straps with lever stretcher

Equipped with adjuster. Hooks to belt with rapid link.



EN 358
CE

MO-52-L

Length: 4 m - Weight: 1 kg

Anti-fall grip

The safety block runs freely on its rope but can be automatically locked in case of a sudden downward drop. Must be used only with special 15 mm Ø rope delivered with the device.



EN 353-3
CE

MO-68/10

With 10 m of rope - Weight: 2.300 kg

MO-68/15

With 15 m of rope - Weight: 3.250 kg

Double safety descent device

Articulated stainless steel cam. Aluminium housing. High-resistance handle. Operates with 9-12 mm diameter lanyard. Ideal for evacuation. Lets you regulate descent.



EN 361
CE

MD-02

Weight: 0.32 Kg

Tether rope with energy absorber

Tether rope in polyamide Ø14 mm.



EN 355
CE

MO-5200

Length: 1.50 m

MO-5201

Length: 2.00 m

Double tether rope with energy absorber

Double tether rope with energy absorber Equipped with 2 steel snap hooks with automatic locking and 1 steel snap hook with screwing locking



EN 355
CE

MO-54010

Length: 1.20 m - Weight: 1.4 kg

Head and eyes protection

Insulating rubber gloves

Insulating mats and platforms

Arc flash equipment

Equipment for working on pole

Snap hooks (stainless steel)



MO-54

EN 362
CE

MO-54

Locks with threaded ring - Opening: 15 mm
100 x 58 mm - 0.154 kg



MO-55/1

EN 362
CE

MO-55/1

Locking by screwing ring on a spring loaded mobile catch; an additional catch is provided to prevent the rope from slipping in the carabiner - 155 x 75 mm - 0.140 kg

Snap hooks (aluminium alloy) zical



MO-54000

EN 362

MO-54000

Oval snap hook - Opening: 15 mm
Individually tested - Weight: 0.071 kg
110 x 58 mm



MO-54004

CE

MO-54004

D-shaped snap hook with automatic locking
Opening: 23 mm - Individually tested
Weight: 0.087 kg - 120 x 72 mm

Fall arrester - retractable type

Designed for lineman safety. Quick acceleration causes instant locking. Corrosion protected steel shell. Integrated braking mechanism and dissipating element. Self locking mechanism and automatic tensioning and return facility. Galvanized cable Ø 4 mm. Strength: 1 200 daN. Delivered with a screw crab. Max. length: 10 m.



EN 360

MO-591002

Weight: 7.00 kg

Snap hook with double safety latch



EN 362
CE

Opening: 50 mm
Body in steel
Fingers in stainless steel
Resistance: 20 kN.

MO-54002

Weight: 0.390 Kg

Tether rope equipped with a tension device

The tether rope is intended to ensure that operators are held in position when working at a height. This tether rope must be associated with a harness belt. Ends sewn to form an attachment and protected with a plastic girdle. Static resistance: 15 kN. Polyamide Ø 15 mm.



EN 358
CE

MO-56009

Weight: 1.425 kg - Length: 3 m

MO-56010

Weight: 1.600 kg - Length: 5 m

Safety rope with wear tell tales

Rope: 14 PEPT multi-filament (15 mm diam.)
Two-colour safety rope, 100% polyester made of 3 white strands with black central thread (wear telltale).
Buckle: Polyamide central lug attaches to snap-hook of belt.



EN 354
CE

MO-052

Safety rope only - Length: 4 m - 0.76 kg

Lanyard

Synthetic fibre ropes - 10 mm. Loops spliced at both ends. Delivered without snap hook.



EN 354
CE

MO-53

Length: 1.50 m - Weight: 0.125 kg

Head and eyes protection

Insulating rubber gloves

Insulating mats and platforms

Arc flash equipment

Equipment for working on pole

Anti fall device with automatic release strap

Winder with self-locking strap.
Length: 2 m.
Equipped with shock absorber.
Allows 2 m of movement autonomy around anchoring point.



EN 360

MO-591000 Weight: 1.160 kg

Constraint tie

Tie in polyamide.

EN 795
CE



MO-52031 Length: 0.8 m - Weight: 0.100 kg

MO-52033 Length: 1.20 m - Weight: 0.135 kg

MO-52034 Length: 1.50 m - Weight: 0.150 kg

Snap hook with stick adapter

Reference	Characteristics	
MO-54005	Opening: 50 mm	Weight: 0.500 kg
CE-5-90-C	Length: 9 m max.	Weight: 4 kg

* Other length, see page 89.



Working on pole kit



Reference	Use
KIT-HAUT-01-(*)	To go up a pole with insulating ladders
KIT-HAUT-02-(*)	To go up a pole with spliced ladders
KIT-HAUT-03-(*)	To go up a catenary
KIT-HAUT-04-(*)	To go up on a pylon
KIT-HAUT-05-(*)	To go up on a roof
KIT-HAUT-06-(*)	To go up using a nacelle

Composition	KIT-HAUT-					
	01-(*)	02-(*)	03-(*)	04-(*)	05-(*)	06-(*)
Harness MO-563	■	■	■			
Harness MO-564				■		
Harness MO-71					■	■
Tether rope MO-52020	■					■
Double tether rope MO-54010		■		■	■	
Constraint tie MO-52034	■	■				
Constraint tie MO-52031				■(2)		
Tether rope with tension device MO-56009	■	■	■	■	■	
Anti-fall grip MO-68/15	■	■	■	■		
Snap hook MO-54	■	■				
Carrying bag M-87-295	■	■	■	■	■	■

(*) add size : M or XL
order example : KIT-HAUT-02-XL.

Head and eyes protection

Insulating rubber gloves

Insulating mats and platforms

Arc flash equipment

Equipment for working on pole

Insulating ladders

A complete range with top quality features: Insulation between two steps: 30000 V (test performed after immersion in water for 24 hours). High mechanical resistance to bending and twisting. Good resistance/weight ratio. High fire resistance. High resistance against bad weather and corrosive elements. Lateral risers in polyester/glass fiber rectangular section 70 x 25 mm. Aluminium alloy rungs with square 29 x 29 mm section and anti-slip coating.



EN 131
CE

Insulating 2 section extension ladders, hand operated

Reference	Folded length	Extended length	Number of rungs	Weight (kg)
MP-514/2	2.41 (m)	4.09 (m)	2 x 8	13.9
MP-515/2	2.97 (m)	5.21 (m)	2 x 10	17

Insulating 2 section extension ladders, rope and pulley operated

MP-506/2	3.53 (m)	6.05 (m)	2 x 12	20
MP-508/2	4.66 (m)	8.30 (m)	2 x 16	31
MP-510/2	5.78 (m)	10.26 (m)	2 x 20	38



Forged steel climbers for round wooden poles

Hard forged steel - Leather belts with cast buckles. Delivered by pair.

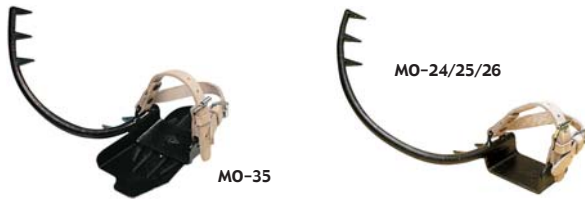

MO-24	Ø 20 cm - 2.6 kg - Pair of climbers
MO-25	Ø 25 cm - 2.8 kg - Pair of climbers
MO-26	Ø 30 cm - 3.0 kg - Pair of climbers
MO-35	Ø 35 cm - 3.2 kg - Pair of climbers

Mechanical climbers for round and hexagonal concrete poles

Manual locking
Adaptable to the pole diameter
For poles Ø 140 to 300 mm.



MO-16-A	Pair of climbers - Weight: 6.5 Kg
----------------	-----------------------------------

Mechanical climbers for rectangular shaped concrete poles

Automatic locking of jaws by elastic cord.
Sole in aluminium alloy, high resistance, with leather belts and steel buckle.
Wear plate placed on sole arm.
Mobile drum on axis can be removed; processed steel rollers.
High resistance aluminium alloy rack, used for clamping onto poles 14 to 42 cm wide.



Spare parts:
MO-17-01: pair of elastic cords
MO-17-02: pair of wear plates
MO-17-03: blade roller
MO-17-04: pair of runners

MO-17-A	Pair of climbers - Weight: 9 kg
----------------	---------------------------------

Climbers for H profile metallic poles

Hard forged steel.
Delivered by pair.



MO-23	Pair of climbers - Weight: 5.10 kg
--------------	------------------------------------

Padlocks, warning signs and delineators

Safety equipment & lamps

Short-circuiting & earthing systems

Voltage detectors and V.I.S / V.D.S

Padlocks

Padlocks with warning signs

Brass ring bow 50 or 70 mm.
Diameter of the ring bow 4 or 6 mm.



Reference	Ring bow (mm)	Ø (mm)	Weight (kg)
AL-230-(*)-EX	50	6	0.170
AL-230-S-(*)-EX	70	6	0.190
AL-230-Z-EX	50	6	0.170
AL-230-S-Z-EX	70	6	0.190
AL-240-(*)-EX	50	4	0.170
AL-240-S-(*)-EX	70	4	0.190
AL-240-Z-EX	50	4	0.170
AL-240-S-Z-EX	70	4	0.190

* Add n° of key: 111 or 222
"00" n° standard key: n° of key upon request
Z: random n° of key

Marking

For indelible writing on the warning signs and padlocks, our ALU-SCRIPT™ markers are ideal.



AS-404

4 markers in assorted colours (red, black, blue and green)

Safety locking badge

Fit with multiple locking apparatus AL-202
White letters on red aluminium
Fixing with 1 hole Ø 10 mm.



AM-467-GB

Ø 80 mm

Handle with 6 padlocks

Handle of moulded plastic for holding up to six padlocks.
Compartment with transparent cover for key storage.



Reference	Weight (kg)	Handle with 6 padlocks
AL-236-111-EX	1.150	AL-230-111-EX
AL-236-S-111-EX	1.210	AL-230-S-111-E
AL-236-222-EX	1.150	AL-230-222-EX
AL-236-S-222-EX	1.210	AL-230-S-222-EX

Multiple locking apparatus

Holds up to four padlocks and a sign.



AL-200



AL-202

AL-200

100 x 60 x 10 mm - Weight: 0.150 kg

AL-202

165 x 50 x 12 mm - Weight: 0.200 kg

Handle for 10 and 30 padlocks

PVC.
Shock resistant.
Ivory colour.
With holes Ø 9 mm.



AL-207/10

For 10 padlocks - Weight: 0.06 kg

AL-207/30

For 30 padlocks - Weight: 0.130 kg

Self adhesive warning signs

Complete range of self adhesive, warning signs conditioned in box of 20, 30 or 50 units.



Reference	Dimensions	Characteristics	Quantity/box
AT-41/025	25 mm side	self adhesive PVC	50
AT-41/05	50 mm side	self adhesive PVC	30
AT-41/1	100 mm side	self adhesive PVC	20
AT-49/025	25 mm side	self adhesive PVC	50
AT-49/05	50 mm side	self adhesive PVC	30
AT-49/1	100 mm side	self adhesive PVC	20
AT-50/025	25 mm side	self adhesive PVC	50
AT-50/053	50 mm side	self adhesive PVC	30
AT-50/1	100 mm side	self adhesive PVC	20
AT-51/025	25 mm side	self adhesive PVC	50
AT-51/05	50 mm side	self adhesive PVC	30
AT-51/1	100 mm side	self adhesive PVC	20
AT-52/05	50 mm side	self adhesive PVC	30
AT-52/1	100 mm side	self adhesive PVC	20
AT-53/05	50 mm side	self adhesive PVC	30
AT-53/1	100 mm side	self adhesive PVC	20
AT-54/05	Ø 50 mm	self adhesive PVC	30
AT-54/1	Ø 100 mm	self adhesive PVC	20
AT-55/05	Ø 50 mm	self adhesive PVC	30
AT-55/1	Ø 100 mm	self adhesive PVC	20
AT-56/05	Ø 50 mm	self adhesive PVC	30
AT-56/1	Ø 100 mm	self adhesive PVC	20
AT-57/05	Ø 50 mm	self adhesive PVC	30
AT-57/1	Ø 100 mm	self adhesive PVC	20
AT-58/05	Ø 50 mm	self adhesive PVC	30
AT-58/1	Ø 100 mm	self adhesive PVC	20
AT-59/05	Ø 50 mm	self adhesive PVC	30
AT-59/1	Ø 100 mm	self adhesive PVC	20
AT-60/05	Ø 50 mm	self adhesive PVC	30
AT-60/1	Ø 100 mm	self adhesive PVC	20
AT-61/05	Ø 50 mm	self adhesive PVC	30
AT-61/1	Ø 100 mm	self adhesive PVC	20
AT-62/05	Ø 50 mm	self adhesive PVC	30
AT-62/1	Ø 100 mm	self adhesive PVC	20
AT-63/05	Ø 50 mm	self adhesive PVC	30
AT-63/1	Ø 100 mm	self adhesive PVC	20
AT-66/1	100 mm side	self adhesive PVC	10



"Customize your labels! On request"

Available on request: Self adhesive rigid plastic warning signs. High Quality, strong sticking on every surfaces: concrete, painted wall, metal, wood, plastic, glass.

Padlocks, warning signs and delineators

Safety equipment & lamps

Short-circuiting & earthing systems

Voltage detectors and V.I.S / V.D.S

Saving kits

Substation signs

Warning signs

Reference	Type	Dimensions	Characteristics
AM-41/1*	aluminium	100 mm side	black on yellow fixing: 3 holes Ø 4.5 mm
AM-41/2	aluminium	200 mm side	black on yellow fixing: 3 holes Ø 4.5 mm
AM-49/1*	aluminium	100 mm side	black on yellow fixing: 3 holes Ø 4.5 mm
AM-49/2	aluminium	200 mm side	black on yellow fixing: 3 holes Ø 4.5 mm
AM-344-GB	aluminium	100 mm side	black letters on yellow fixing: 3 holes Ø 4.5 mm
AM-345-GB	aluminium	100 mm side	black letters on yellow fixing: 3 holes Ø 4.5 mm
AM-344/05	aluminium	50 mm side	
AM-344	aluminium	100 mm side	

*Pack of 10 units.

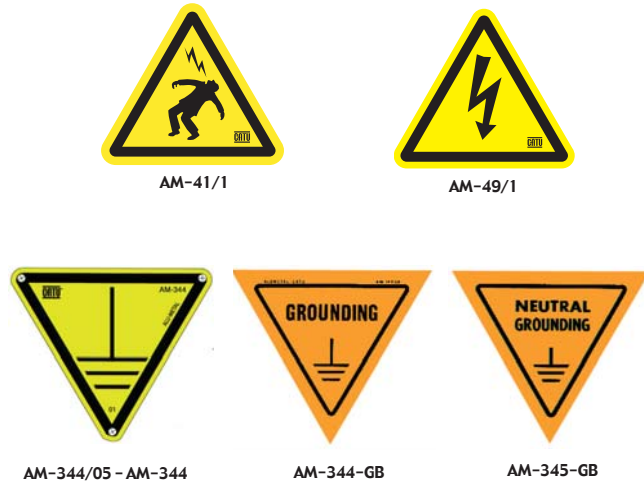

Specialized signs

Reference	Type	Dimensions	Characteristics
AM-20-GB	aluminium	350 x 250 mm	blue letters on plain aluminium
AM-20-RM	aluminium	350 x 500 mm	blue letters on plain aluminium
AM-61-GB	aluminium	150 x 200 mm	
AM-61-RM	aluminium	150 x 200 mm	
AM-215-RM	aluminium	350 x 250 mm	black on yellow SF6 warning
AM-282/2-RM	aluminium	200 x 60 mm	
AM-7002	aluminium	300 x 200 mm	black on yellow
AM-33/3	aluminium	Ø 300 mm	red-black on alu
AM-34/2	aluminium	Ø 200 mm	red-black on alu
AM-32/3	aluminium	Ø 300 mm	
AP-510-GB	plastic	420 x 297 mm	golden rules
AP-951/2	plastic	200 x 200 mm	red on white



Other models, please consult us!



AP-951/2



AM-33/3



AM-34/2



AM-32/3



AM-61-GB



AM-61-RM

Warning sign

Attachment: one hole Ø 10 mm.
Marking for indelible writing: see page ??.



AP-499/1

Reference	Type	Ø (mm)
AP-499/1	plastic	100

Warning flags

Brightly colored ribbon.



AL-53

Reference	Dimensions (mm)	Fixing
AL-53	650 x 350	on handle

Grounding flags



AL-60

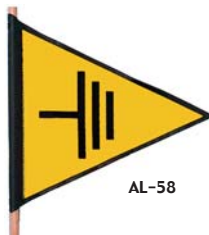

AL-58

AL-58	Fixing on handle; for work site
AL-60	Fixing on earthing cable; for immediate identification in open-type switchgears possible inscription: 0 to 99 (by using ALU-SCRIPT markers)

Safety boundary post

For temporary installation.
Used with tough link chain delineators (AL-32/05)
Removal Foot.
Ø 50 mm.
Height: 0.9 m.



AL-316



AL-318

AL-316	Red and white - Weight: 4.2 kg
AL-318	Black and yellow - Weight: 4.2 kg

Chain delineators

Polyamide chains.



AL-31/25



AL-32/05

AL-31/25	Red and white - Length: 25 m
AL-31/05	Red and white - Length: 5 m
AL-32/05	Black and yellow - Length: 5 m
AL-31	Opening ring for AL-31/25

Delineators

Brightly colored ribbon.
Snap hook on one ribbon end and another on spool.
A ring on spool brakes ribbon at desired length.
wide: 50 mm
length: 20 m.



AL-62-A



AL-63-A

AL-62-A	Red ribbon
AL-63-A	Yellow ribbon

Padlocks, warning signs and delineators

Safety equipment & lamps

Short-circuiting & earthing systems

Voltage detectors and V.I.S / V.D.S

Saving kits

Intervention kits



CG-35/1



CG-30 (IEC 60903)



CI-23



CT-7-25/1

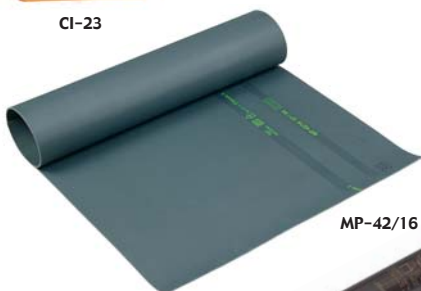

MP-42/16



MP-20

CS-45

Composition of the kits

Reference	Composition	Characteristics	Dimensions
CG-30-C	Insulating rubber gloves	26 500 V max	size 10
CG-35/1	Rubber gloves storage box with window		60 x 210 x 460 mm
CI-23	Fuse holder		90 x 240 x 260 mm
CS-45	Rescue stick	45 kV	1.65 m
CI-06-D	Wall mounted supports	Delivered with CS-45	
CT-7-25/1*	Insulating platform	24 000 V max	500 x 500 x 220 mm
MP-42/16**	Insulating MAT	≤ 26,5 kV	0.6 x 1 mm

KIT-01*

Intervention kit with insulating platform

KIT-10**

Intervention kit with insulating mat delivered with a protective P.V.C. container

Safety lamps

For MV indoor substations.



CD-122



CD-124

CD-122

Halogen lamp - Automatic switch on in case of power break
Adjustable flood beam - power beam: 5.5 W
Operates: 3 hours - Weight: 1.2 kg

CD-124

Delivered with a wall mounted support
Bulb: 6 W/12 W
Operates: 1 hour (12 W), 2 hours (6 W)
Rechargeable on 230 V 50/60 Hz
3 positions switch: Off, 6 W, 12 W
100 x 190 x 220 mm - Weight: 1.9 kg

Intrinsically safe ATEX torch light

 II 2GD EEx ibe IIC T4 or T6.
Zone 1 and 2 - 21 and 22.

- Simple optical system.
- Power supply by 1.5 V LR20 batteries (x3).
- Bulb P13, 559 - 3.7 V - 0.3 A.
- IP 66.



CD-103

Torchlight Ø 50 x 244 mm - Weight: 0.250 kg

MS-115-1

Bulb for CD-103 (ordering by 5)

Double optical systems.

 II 2GD EEx ibe IIC T6 or T4 or T3.
Zone 1 and 2 - 21 and 22.

Protection mode (suitable for all areas and gases).

Appropriate certificates for Merchant Marine and VERITAS.

Power supply by 1.5 V LR20 batteries (x2).

Fixed light or intermittent optical signals.

IP 66/68.



CD-104

Dimensions: 230 x 90 x 90 mm - Weight: 400 g

Intrinsically safe ATEX LED's Headlamp

 II 2GD EEx ia IIC T4. CE

Can be carried either on the head or any kind of helmet.

- Lighting by 3 high performance White LEDs.
- 2 lighting levels (High: 3 LEDs on or low: 1 LED on).
- Adjustable lamp height angle.
- Very light, ABS body.
- ATEX certified Categorie 2 (Zone 1)
N° TRL03ATEX21005X.
- Range: 10 to 15 meters.
- Powered by 3 batteries LR03 (AAA).
- Autonomy: 150 hours.
- Strap: cloth or silicone rubber (for helmet).



MS-126

Delivered with batteries - Weight: 0,125Kg

M-95-864

Hooks set for helmet

IEC short-circuiting and earthing systems for MV substations

These equipment are intended for connection: to permanent fixed points or to bare conductors. They consist of 3 contact clamps.

IEC-61230

1 short-circuit earthing connection set consisting of 3 extra-flexible copper cables with silicone sheath, L = 1.5 m each. 1 trifurcation connector earthed by an extra-flexible copper cable with silicone sheath, L = 2.5 m. 1 earthing clamp. 1 plastic case (M-78665).

Installation on permanent fixed points

Installation on bare conductors



Plastic case
M-78665 included



Plastic case
M-78665 included



MT-1910
MT-1920

CE-5-40-E



MT-5805

CF-4-21-C

Reference	MT-1910	MT-1920
Icc (kA/1s)	20	30
Installation on fixed points	Ø 20 mm MT-2951 range	Ø 25 mm MT-3951 range
Composition	3 clamps MT-1911-E 1 MT-1911	3 clamps MT-1921-E 1 MT-1921
Connection set	3 cables 95 mm ² 1 earth cable 35 mm ²	3 cables 150 mm ² 1 earth cable 50 mm ²
Sticks**	CF-5-40-E	CF-5-40-E

** Stick to be ordered separately

For earthing systems to your own specifications, please see page 119.

Reference	MT-5805	MT-9801
Icc (kA/1s)	20	10
Conductors (mm)	● Ø 5-35 ■ 16-40 ■ 5-35	● Ø 5-16 ■ 0-16 ■ 40-16 ● Ø 5-28
Composition	3 clamps MT-815-C 1 earth clamp MT-840/1	3 clamps MT-817-C 3 clamps MT-814/2 1 earth clamp MT-840/1
Connection set	3 cables 95 mm ² 1 earth cable 35 mm ²	3 cables 50 mm ² 1 earth cable 25 mm ²
Sticks**	CE-4-21-C	CE-4-21-C

Padlocks, warning signs and delineators

Safety equipment & lamps

Short-circuiting & earthing systems

Voltage detectors and V.I.S / V.D.S

Saving kits

Clamps for MV installations and substations

Attachment (C-Type)

Hexagonal end-fitting. A circumferential braking system prevents the clamp from turning under the weight of the cable. Separates by simple pulling.

Earth cable connection

With a crimped lug (12 mm Ø hole).

Material

Aluminium alloy except MT-814, MT-1911 and MT-1921: copper-aluminium bronze.

Reference	Weight (kg)	Dimensions (mm)	Conductors (mm)	Test current (kA/1s)
MT-812-C	0.320	35 x 79 x 143	• Ø 5-16 — 0-16	21
MT-813-C	0.330	35 x 79 x 169	• 40 x 16	21
MT-814/2	0.660	85 x 56 x 192	• Ø 5-28	14.5
MT-817-C	0.330	30 x 90 x 140	• Ø 5-16 — 40 x 16	21
MT-814/3	0.620	85 x 56 x 195	• Ø 18-33	14.5
MT-815-C	0.650	44 x 108 x 173	• 5-35	30
MT-815-E			— 16-40	
MT-815-S			• 5-35	
MT-815-S1			— 16-40	
MT-1911-E MT-1911-S1	0.580	For permanent fixed point Ø 20 mm and round conductors Ø 8 to 18 mm		20
MT-1921-E MT-1921-S1	0.69	For permanent fixed point Ø 25 mm and round conductors Ø 10 to 25 mm		30



Earth clamps

Copper aluminium bronze earth clamps.

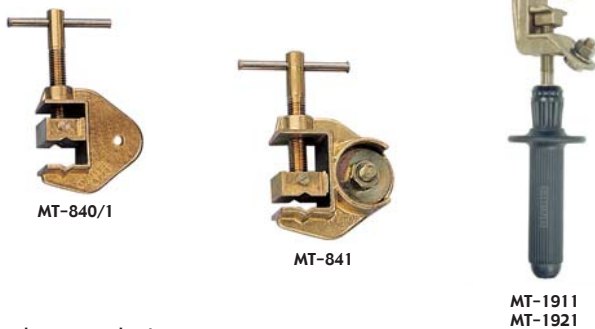

For bare conductors.

Reference	Weight (kg)	Connection	Conductors (mm)
MT-840/1	0.48	Connector: TO-08 - 35 mm ²	• Ø 6-25 — 0-25
MT-841	0.48	Connector: ≤ 50 mm ²	• Ø 6-25 — 0-30

For fixed point.

Reference	Weight (kg)	Connection conductors (mm)
MT-1911	0.58	Spheric fixed points MT-2951 Ø 20 mm Round conductors Ø 8 to 18 mm
MT-1921	0.69	Spheric fixed points MT-3951 Ø 25 mm Round conductors Ø 10 to 25 mm

Fixed points



For flat conductors.

Reference	Sphere dimension	Weight (g)	Fixing
MT-2951	Ø 20 mm	130	Thread: M 12
MT-2951/1	Ø 20 mm	180	Bolt: M 12 - L = 35 mm
MT-2951/2	Ø 20 mm	200	Bolt: M 12 - L = 45 mm
MT-2950/35*	Ø 20 mm	247	Bolt: M 12 - L = 35 mm
MT-3951	Ø 25 mm	240	Thread: M 12
MT-3952	Ø 25 mm	240	Thread: M 16
MT-3951/1	Ø 25 mm	300	Bolt: M 12 - L = 45 mm
MT-3952/1	Ø 25 mm	350	Bolt: M 16 - L = 45 mm
MT-3950/35*	Ø 25 mm	300	Bolt: M 16 - L = 35 mm

* = not IEC

Insulating sticks for substation use

Telescopic sticks for voltage detectors and earthing systems for use in dry and wet conditions

Telescopic stick contains 2 elements made of resin polyester/glass fiber foam filled tube, which slide together and are equipped with a push button lock. **IEC-61235** ⚠

Reference	Rated insulation (kV)	Ø (mm)	Overall length (m)		Weight (kg)
			folded	extended	
CE-4-21*	90	41/32	1.15	2.00	1.50

* Add end-piece C, K or E

Fixed length stick for use in dry and wet conditions

Manufactured from 36 mm dia. elements, with single 100 dia. skirts, light and rigid, shock resistant. **IEC-61235** ⚠

Reference	Rated insulation (kV)	Ø (mm)	Overall length (m)	Weight (kg)
CF-5-40*	40	36	1.50	1.15

* Add end-piece C, K or E

Standard stick for use in dry conditions

Reference	Rated insulation (kV)	Ø (mm)	Overall length (m)	Weight (kg)
CF-3-72*	72.5	36	1.50	0.88

* Add end-piece C, K or E

Short length clamp stick

IEC-61235 ⚠

Reference	Ø (mm)	Overall length (m)	Weight (kg)
MG-115/1-S	32	1.50	2.40

Wall mounted supports

For sticks and voltage detectors. Plastic. Delivered with wood screws.

Reference	Top	Bottom
CI-06-D	Ø 28-30 mm	Ø 36 mm max.
CI-10-D	Ø 28-36 mm	Ø 58 mm max.
CI-12-D	Ø 28-30 mm	Ø 58 mm max.



CE-4-21-C



CF-5



CF-3



MG-115/1-S



Top



Bottom

Padlocks, warning signs and delineators

Safety equipment & lamps

Short-circuiting & earthing systems

Voltage detectors and V.I.S / V.D.S

Saving kits

Earthing and short-circuiting systems for 250 A separable connectors

Rating = 12.5 kA/1s

Equipment consisting of:

3 terminals, each fitted with a "handarff device" for locking.

1 terminal connecting kit, with double-crimped connectors

• 3 copper cables, 70 mm² section, length ~ 0.70 m

• 1 copper cable, section 35 mm², length ~ 2 m

• 1 earthing clamp MT-840/1

3 padlocks AL-230-S.

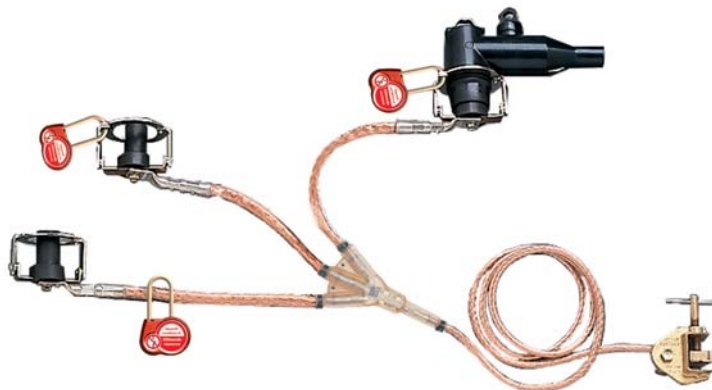

MT-8612

Delivered in metal box
620 x 195 x 150 mm - Weight: 7.6 kg

Earthing and short-circuiting systems for 400 A separable connectors

Rating = 12.5 kA/1s

Equipment consisting of:

3 terminals, each fitted with a bolted stirrup for locking.

1 terminal connecting kit, with double-crimped connectors

• 3 copper cables, 70 mm² section, length ~ 0.40 m

• 1 copper cable, section 35 mm², length ~ 2 m

• 1 earthing clamp MT-840/1

3 padlocks AL-230-S.



MT-8614

Delivered in metal box 480 x 340 x 195 mm
Weight: 13.5 kg

Voltage tester for M.V. separable connectors



CC-151-K

For details see page 76.

Voltage tester for M.V. separable connectors

Check the absence of voltage on the capacitive terminals of plug-in M.V. bushings.
 Sensor in the form of a bent finger enabling removal and reinstallation of the terminal insulating cover.
 Signal via beeping and bright red flashing of electro-luminescent diodes.
 Built-in function test via the "TEST" button which covers the entire device.
 Permanent stand-by state.
 Power supply: four 1.5 V, R-6 batteries.
 Mounting on insulating stick via a universal end.



CC-151-K

Tester in rigid case with batteries
 70 x 100 x 165 mm - 0.70 kg

CC-45-K

Special 45 kV insulating stick
 L = 1.25 m - 0.6 kg

Voltage detector

For indoor use
 Built-in device for checking operation of the led's indicator via a piezo-electric generator.
 High-brightness led's indicator.
 Sturdy thermo-plastic moulded case providing.
 Pivoting contact electrode enabling wire contact at any angle.
 Telescopic insulating stick.

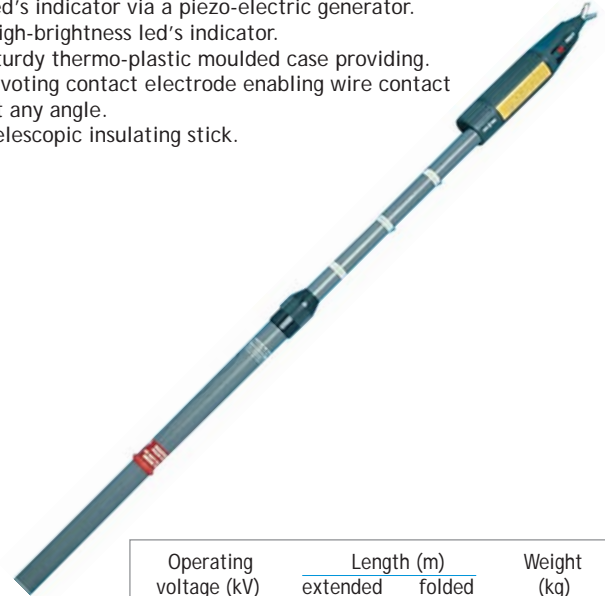

Operating voltage (kV)	Length (m)		Weight (kg)
	extended	folded	
5-40	1.26	0.85	0.95

CL-4-41/2

Delivered in a waterproof fabric case with strap - Weight: 0.95 kg

Permanent luminous indicator

Permanently installed on bus bars, luminous indicator signals the presence of voltage at a glance.
 Single-pole 5 to 75 kV indicators.
 Signaling the presence of voltage by 7 electroluminescent diodes.
 For indoor use.



CL-40010

For round 5 to 20 mm Ø wires and 1 to 20 mm flat bars

Voltage detector "compact serie"

For indoor use
 This compact serie voltage detector is designed to be carried easily by operators.
 Voltage presence is indicated by a high-brightness LED's indicator.
 Built-in device for checking of the LED's indicator by a piezotest generator.
 Equipped with a telescopic handle.

Delivered in holster.



Reference	Operating voltage (kV)	Extended	Folded	Weight (kg)
CL-2-5/36-2	5-36	0.7	0.3	0.4
CL-2-10/30-2	10-30	0.7	0.3	0.4

*Electronic type detectors can also be used.
 Please refer pages 79/80/82.*

Padlocks, warning signs and delineators

Safety equipment & lamps

Short-circuiting & earthing systems

Voltage detectors and V.I.S / V.D.S

Saving kits

We can deliver complete set with foot capacitance, head capacitance and wirings to your own specifications. Please consult us.



Integrated voltage indicating system (V.P.I.S)



IEC 61958 

Indicates the voltage presence on M.V. cubicles by being installed on the capacitive dividers. Voltage of use behind capacitive dividers: $V < 1000$ V. Light threshold: 90 V. Signalling: 3 neons. Attachment: male/female plugs.

CL-495-3

Packaging: vinyl cover
Dimensions: 130 x 30 mm

Integrated voltage detecting system (V.D.S)



IEC 61243-5 

Indicates the voltage presence on M.V. cubicles by being installed on the capacitive dividers. Voltage of use behind capacitive dividers: 1000 V (between phase and earth). Light threshold: 70/90 V. Input impedance: 36 MΩ. Signalling by 3 red diodes.

CL-497-00

Packaging: vinyl cover
Dimensions: 146 x 30 mm

Interface for integrated voltage detecting system (V.D.S)



IEC 61243-5 

Indicates the voltage presence on M.V. cubicles by being installed on the capacitive dividers. For High impedance detecting systems Input impedance: 36/43 MΩ. Voltage indication by 4 mm standard sockets on the front of the indicator.

CL-498-00

Packaging: vinyl cover
Dimensions: 146 x 30 mm



Sound phase comparator

IEC 61243-5 



The MX-404 sound phase comparator checks the concordance between 2 phases. The comparator's operation is indicated by: Emission of an audible signal when there is discrepancy between the two phases. Absence of an audible signal when there is no discrepancy between the two phases. Power supply: 9V type 6LR battery.

MX-404

Delivered in a storage box
Dimensions: 145 x 80 mm

Separable voltage detecting system (V.D.S)

IEC 61243-5 



CL-499/101

This device enables to check the absence or presence of voltage on three phases (L1, L2, L3). HR high impedance. Voltage max: 1080 V rms. 50/60 Hz. Voltage presence: red flashing LED > 1 Hz. Fits in CL-498 devices.

CL-499/101

Delivered in plastic bag

Life saving kits for M.V. substations

Wall mounted KIT

In case of an electrical accident, quick response is essential: seconds gained or lost can decide the life or death of a victim.

Our life saving equipment is designed to make all necessary materials immediately available to rescue personnel.

It includes:

- 1 rescue telescopic stick
- 1 voltage detector with flexible antenna contact (with autotest)
- 1 cable cutter with insulated handles
- Forged steel blades maximum opening: 30 mm
- 1 insulating platform, 24 kV high voltage
- Insulating gloves, insulating boots
- Safety instructions on the plastic board
- 1 talcum powder can.



Compact carrying KIT

This compact kit is designed especially to be carried in a vehicle for safety electrical intervention. Made in two part (of moulded material: PEHD), the case is also on its red part, an insulating platform.

Composition of the kit:

- 1 insulating platform
- 1 telescopic insulating stick
- 1 voltage detector with autotest
- 1 rescue hook
- 1 insulated cable cutter
- 1 pair of insulating gloves
- 1 pair of insulating boots
- 1 talcum powder can
- 1 safety instructions and safety first aid posters
- 1 adhesive tape (black and yellow).



CZ-54-R	Wall mounted panel 0.84 x 0.745 x 0.27 m 21 kg - With instructions in English - 24kV
CZ-54-MR	Same as CZ-54-R With instructions in English/Arabic - 24kV
CZ-55-R	Same as CZ-54-R except use tension: 36 kV
CZ-55-MR	Same as CZ-55-R With instructions in English/Arabic - 36kV

CZ-53-R	710 x 570 x 240 mm - Weight: 18.5 kg with instructions in English - 25kV
CZ-53-MR	Same as CZ-53-R with instructions in English/Arabic - 25kV
CZ-53-R/2	Same as CZ-53-R except use tension: 36 kV
CZ-53-MR/2	Same as CZ-53-R/2 With instructions in English/Arabic - 36kV

Rescue stick

Insulating stick ended by a large hook in order to rescue quickly an electrified victim in case of accident.

CS-45	Length: 1.65 m - Rated insulation: 45 kV Delivered with wall mounted supports.
--------------	---



IEC voltage detectors

Standard voltage detector

Insulating sticks for voltage detectors

Phase comparators

IEC electronic Voltage Detectors, "Compact serie" for indoor and outdoor use

Ultimate technology of voltage detector "Head Capacitive Technology"

IEC-61243-1
 CE

Compact and light

It offers:

- a wide band (10/36 kV)
- a universal application (50/60 Hz)

Voltage presence is indicated by:

- red flashing LED (very bright -visible at more than 20 m in direct lighting)
- powerful rated audible signal > 60 dB(A)/2 m

Operating check:

By pressing the TEST button, correct operation is indicated as follows :

- a red LED flashes on
- sound signal

(during and after this test, the timed green LED lights up. While remaining on, it indicates the good working order of the detector)

Characteristics:

- Detectors have unitary adjustment and are checked by routine test
- Dielectrically tested on substation bars (bridging test)
- Precise and stable operating threshold
- Reduced sensitivity to induced voltages
- Reduced sensitivity to interference field
- High environmental resistance (impacts, vibrations, moisture)

Use from 50 to 60 Hz

Temperature conditions: class N (IEC-61243-1 standard)

Storage and operation: -25/ +55 °C

Robust housing

Power supply: 1 x 9V alkaline battery type 6LR61

Contact electrodes fitted to the housing by screwing and are easily interchangeable

End fittings:

C = hexagonal 12 mm, for hexagonal end-fitting sticks

K = universal, for universal end-fitting sticks

Weight of the detector: 420 g

Size of the detector: Ø 59 x 270 mm

Packaging: unit supplied complete in a case with batteries and contact electrodes

Total weight: 1100 g

Total size: 340 x 275 x 83 mm

Recommended stick:

CE-4-21. See page 81.



Medium voltage

Frequency 50/60 Hz

Reference	Operating voltage (KV)
CC-875-10/36*	10-36
CC-875-11/33*	11-33

* Specify type of mounting when ordering: C or K.

For other voltages, please consult us.

Standard electronic voltage detector for indoor and outdoor use

With a precise and absolutely stable operating threshold, the DETEX ELECTRONIC DETECTORS offer users maximum safety on MV lines and installations.

Double signalling

- Voltage presence is indicated by both:
- extremely bright red flashing LED's (visible at more than 50 meters even in unfavourable light),
 - powerful rated audible signal > 60 dB/2 m.

Checking

By pressing the test button, the operator checks that the detector is working properly. When the test button is released, a timed green LED lights, indicating both the detector is operational and the self testing of the unit continues.

Continuous monitoring conditions

High reliability

- Tropicalized: -25 / +55 °C.
- housing made from polycarbonate with high mechanical properties and dielectric strength.

Removable electrode

Power supply

- four 1.5 V batteries type LR 6.

End fittings:

- "C" for hexagonal sticks.
- "K" for universal sticks.

Weight

500 g with batteries.

Packaging

Units supplied complete in a case with batteries and two contact electrodes (straight and V-shaped) - 390 x 90 x 90 mm
Weight: 0.800 kg.

Recommended sticks:

CE-4-21. See page 81.



CC-363-C

CC-363-K

Reference	Operating voltage (Ph/ph - kV)
CC-363*	5-36

* Specify type of mounting when ordering: C or K.

CC-365-101	Flag/Vee contact electrode
C-92-492	Contact electrode for installations L = 310 mm, insulated on 300 mm

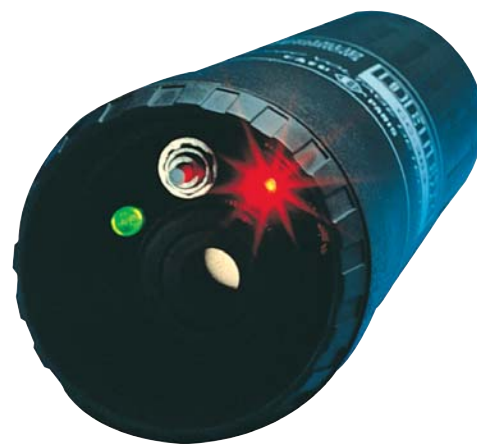
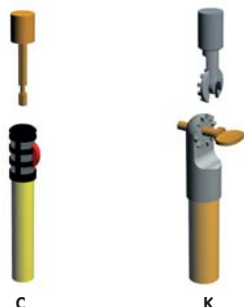

For other voltages, please consult us.

IEC voltage detectors

Standard voltage detector

Insulating sticks for voltage detectors

Phase comparators

Telescopic sticks for voltage detectors

Telescopic stick contains 2 elements made of resin polyester/glass fiber foam filled tube, which slide together and are equipped with a push button lock. **IEC-61235** 

Reference	Rated insulation (kV)	Ø tube (mm)	Overall length (m)		Weight (kg)
			folded	extended	
CE-4-21*	90	41/32	1.15	2.00	1.50

* Specify type of mounting when ordering: C or K.

Telescopic sticks for voltage detectors

Contains 2 elements: ****IEC-60855** 
 A yellow lower element made of resin polyester/glass fiber foam filled 41 mm diameter base tube.
 An upper orange element made of glass fiber/resin epoxy foam filled of 32 mm diameter (**).

Reference	Rated insulation (kV)	Ø tube (mm)	Overall length (m)		Weight (kg)
			folded	extended	
CE-75*	75	41/32**	1.15	2.00	1.20

* Specify type of mounting when ordering: C or K.

Extension for insulating sticks

Extension with a male end-piece. **IEC-61235** 

Reference	Length (m)	Weight (Kg)
CM-7-10-A	1.00	1.10



Medium voltage

Connection adaptors see page 91.

Unlike single-pole voltage detectors, two-pole testers may detect differences in voltage between any two points of an installation. Essentially used for phase balance operations, they may also be used for two-pole detection operations and H.V. fuse checking.

Two-pole Phase comparators for indoor use

The DETEX CL-8-36 detect differences in voltage between any two points of an installation indicated by LED's. It also enables assessment of the order of magnitude of the residual voltage induced by nearby live lines or circuits, and thus differentiates it from the one provided directly from a high voltage source.

Wide range of voltages: 2 to 36 kV.

High luminosity.

Compact: 0.62 m with probes dismantled.

High dielectric quality insulating material.

Two 1.25 m elements with removable probes, connected via a high-insulation lead.

Max. use distance: 2.25 m (with probe extenders).

Operation testing: with a checking device.



CL-8-36

CL-8-36 tester in plastic case
150 x 195 x 650 mm - Weight: 7.5 kg

CL-8-36/1

CL-8-36 tester with two probe extenders
0.550 m - cable, length: 2.87 m delivered
in plastic case 150 x 195 x 650 mm
Weight: 7.8 kg

ACCESSORIES

C-92-20

Spare 0.550 m probe

CL-8-05

Probe extenders 0.550 m

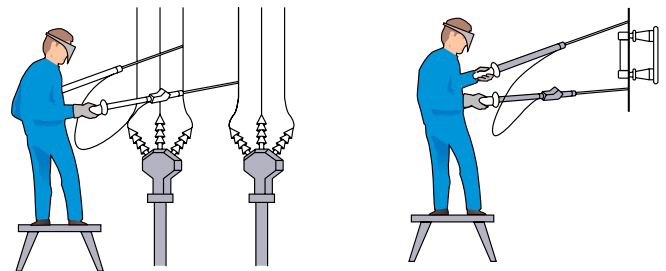

Checking for phase matching

Checking a H.V. fuse

PIEZOTEST™ Separate testing device for phase comparator

Piezo-electric generator activated via a handle mechanism providing a high frequency voltage. Metal contact at the tip of the device. This contact may receive the "banana" plug of the extension lead to facilitate testing on very long detectors. Earth socket at the base of the unit receiving a plug for making closed-circuit tests.



CL-1-05

In case, with lead - 190 x 32 x 65 mm
Weight: 0.300 kg

IEC voltage detectors

Standard voltage detector

Insulating sticks for voltage detectors

Phase comparators

Single pole phase comparator for indoor and outdoor use

Frequency and voltage phase memory.
 Integrated TEST push-button.
 Orange LED = indication that frequency and voltage are in memory.
 Green LED = phasing indication.
 Red LED = non-phasing indication.
 Powered by a 6 LR 61 9 V battery.
 Delivered in carrying case.

IEC-61481



Reference	Voltage (kV)	Length of antenna (m)
CL-7-06/18*	6-18	0.85
CL-7-10/30*	10-30	0.85
CL-7-10/30-1*	10-30	1.15
CL-7-12/36*	12-36	1.20

* Please specify type C or K when ordering.

For other voltages, please consult us.

Two-pole phase comparator for indoor and outdoor use

Precise indications provided by the galvanometer needle;
 dials are calibrated according to voltage.
 Assessment of the voltage value on testers/measurers.
 Complete function testing:

- built-in, with TEST push-button (battery supplied).

Consists of two elements connected by a high-insulation lead.
 Removable handles.
 Device delivered in metal case.
 140 x 250 x 850 mm - 7.5 kg.



Reference	Voltage (kV)	Dial scale (kV)	Observations
Phase tester			
CL-5-33-GB	11-33	11-33 A.C/D.C	straight and angled antennae
CL-5-36	5-36	5-10-15-20-25-30-36 A.C/D.C	straight antennae
Tester-measurer			
CL-5-03	0.75-3	0.75-1-1.25-1.5-3 A.C/D.C	straight antennae

Copper and aluminium cables

Copper cables

Extra flexible braided multi-strand cables.

- A** Transparent PVC sheath, with cable section identification.

IEC-61230 Δ

- B** Transparent silicon sheath according to IEC-61230. Resistant to temperature variations (-40 °C to +70 °C) with double IEC triangle marked on cable section.



A	B IEC-61230 Δ	Rating (kA/1s)	Cable		Section (mm ²)
			Weight (kg/m)	\varnothing (mm)	
M-24-10		2	0.105	4.5	10
M-24-16	M-24-16-S	3.5	0.156	5.6	16
M-24-25	M-24-25-S	6	0.275	7.5	25
M-24-30		7	0.330	8	30
M-24-35	M-24-35-S	8	0.386	9	35
M-24-40		10	0.440	9.5	40
M-24-50	M-24-50-S	12	0.545	10	50
M-24-70	M-24-70-S	16	0.768	12	70
M-24-75		20	0.800	12	75
M-24-95	M-24-95-S	20	1.000	14	95
M-24-120	M-24-120-S	30	1.280	17	120
M-24-150	M-24-150-S	40	1.630	19	150

Aluminium cables

Extra flexible braided multi-strand cables.

Transparent PVC sheath, with cable section identification.



Reference	Rating (kA/1s)	Cable		Section (mm ²)
		Weight (kg/m)	\varnothing (mm)	
M-28-50	7.0	0.170	11.5	50
M-28-70	10.0	0.240	13.4	70
M-28-120	17.5	0.430	19.00	120
M-28-150	20.0	0.510	21.00	150

Jumper cables realisation specially manufactured items



Quotations in accordance with faisability.
For all details:
Tel.: 33 142314624 / www.catuelec.com

Copper cables only:
Heating curves (Gut & Grundberg method)

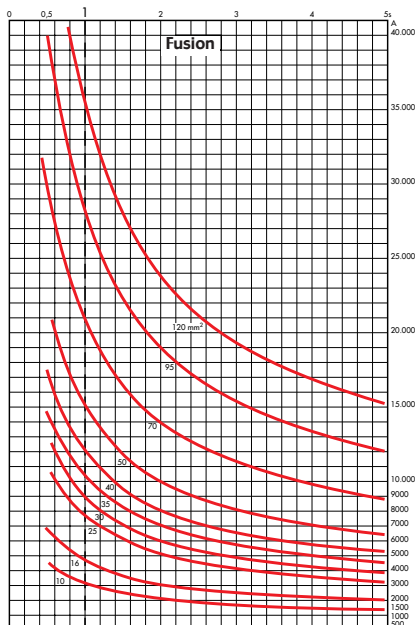

Copper cables only:
Heating curves - 300 °C

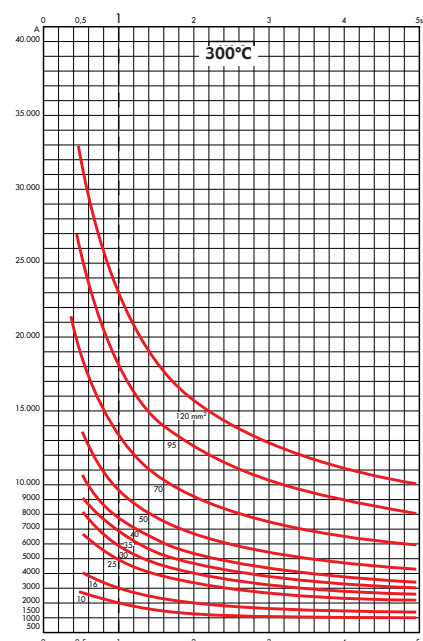

Cables

Overhead line systems

Insulating sticks

Specific sticks and bags

Underground systems

IEC-61230

In the context of the IEC-61230 international standard, CATU offers and answers to your needs with a large range of short-circuiting and earthing systems for substations and lines. These equipments are fitted with silicone-sheathed cables and double-crimped lugs at both ends: crimped once to the cable itself and once to the cable envelope.

This type of connection has been mechanically tested by simultaneous traction and twisting, followed by a proofing test in a soda bath. Before the short-circuiting tests, all components of this equipment are subjected to a cycle in a saline mist, to provide artificial ageing.

IEC short-circuiting and earthing systems (three-phase crossarm networks)

MT-613 clamps are automatic contact clamps. They are put into position from above the conductor, using the clamp dispenser head MT-635/1-C, which gives remarkable rapidity and ease of handling. Removal is carried out by pulling down the clamp, which revolves around the conductor by means of the pig tail fixed in the centre of the clamps dispenser head.

Characteristics	MT-6613	MT-6613/1
Rating	8 kA/1s	25 kA/0.5s 17.5 kA/1s
Connection copper cable between clamps (mm ²)	35	95
Earth connection copper cable (mm ²)	16	35
For conductors Ø (mm)	5 to 30	5 to 30
Recommended sticks**	CE-4-21-C (P. 74)	CF-5 serie (P. 88) CM-4400 serie (P. 88)

Earth rod - 1 m:

MT-650/MT-652/10 or MT-652/15 to be ordered separately.

** To be ordered separately.

IEC-61230 



Reference	Rating	Equipment composition
MT-6613	8 kA/1s	<ul style="list-style-type: none"> - 3 automatic contact clamps MT-613 - Connection cables 35 mm², max. gap between clamps: 2.75 m - 1 clamp dispenser head MT-635/1-C - 1 spool with earthing cable connection MT-640-S - 1 carrying bag M-87295
MT-6613/1	25 kA/0.5s 17.5 kA/1s	<ul style="list-style-type: none"> - 3 automatic contact clamps MT-613 - Connection cables 95 mm², max. gap between clamps: 2.75 m - 1 clamp dispenser head MT-635/1-C - 1 earthing cable connection 15 x 35 mm² - 1 earthing clamp MT-840/1 - 1 carrying bag M-87295

For earthing systems to your own specification please see page 119.

Short-circuiting automatic contact clamps

Aluminium alloy.

Reference	Rating	For conductors Ø (mm)
MT-613	25 kA/0.5s or 17.5 kA/1s	5 to 30
MT-613/1	10 kA/1s	5 to 30
MT-613/2	8 kA/1s	5 to 30



MT-613



MT-613/1
MT-613/2

Clamp dispender heads

Copper aluminium alloy.

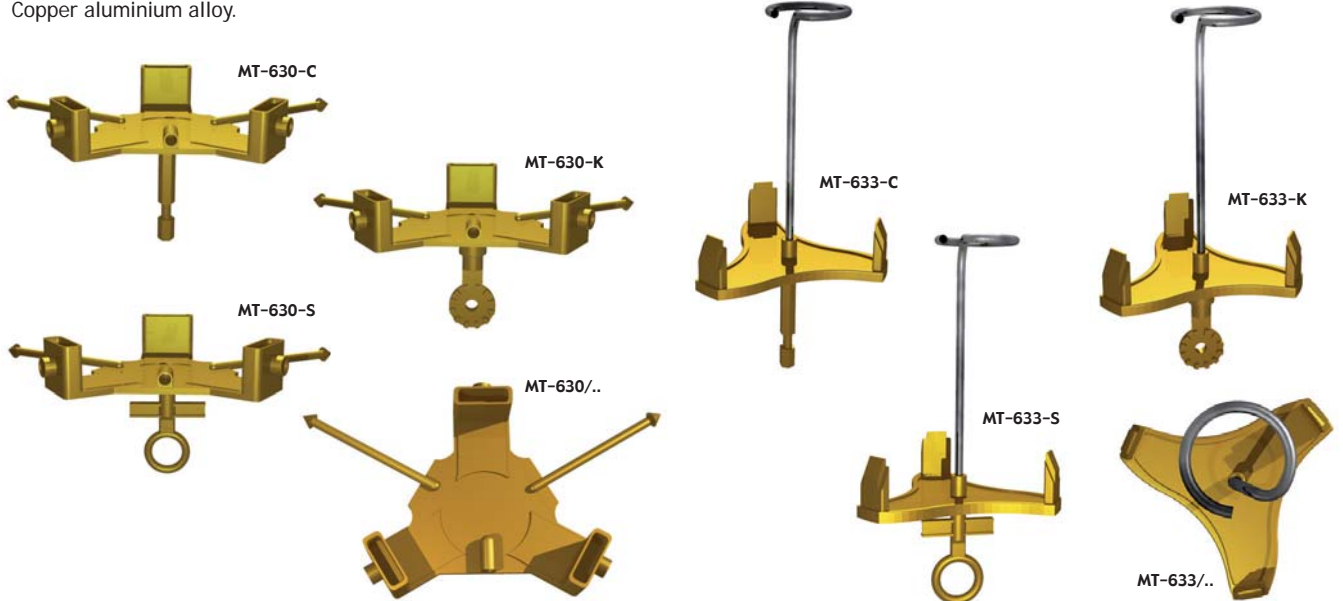

For MT-613 clamp

Reference	Head for 3 clamps	Head for 4 clamps	With pigtail hook
MT-630-C	<input checked="" type="checkbox"/>	<input type="checkbox"/>	<input type="checkbox"/>
MT-630-K	<input checked="" type="checkbox"/>	<input type="checkbox"/>	<input type="checkbox"/>
MT-630-S	<input checked="" type="checkbox"/>	<input type="checkbox"/>	<input type="checkbox"/>
MT-635/1-C/K/S	<input checked="" type="checkbox"/>	<input type="checkbox"/>	<input checked="" type="checkbox"/>
MT-634-C/K	<input type="checkbox"/>	<input checked="" type="checkbox"/>	<input type="checkbox"/>

For MT-613/1 and 613/2 clamps

Reference	Head for 3 clamps	Head for 4 clamps	With pigtail hook
MT-633-C	<input checked="" type="checkbox"/>	<input type="checkbox"/>	<input checked="" type="checkbox"/>
MT-633-K	<input checked="" type="checkbox"/>	<input type="checkbox"/>	<input checked="" type="checkbox"/>
MT-633-S	<input checked="" type="checkbox"/>	<input type="checkbox"/>	<input checked="" type="checkbox"/>
MT-634/1-C/K	<input type="checkbox"/>	<input checked="" type="checkbox"/>	<input checked="" type="checkbox"/>

Earth rod

Reference	Characteristics	Length (m)
MT-652/10	Screw ground rod.	1
MT-652/15	Screw ground rod.	1.50
MT-650	Hexagonal section rod.	1



MT-652/10



MT-650

Earth clamp

Copper aluminium bronze earth clamps.



MT-840/1



MT-843

Reference	Weight (kg)	Conductors (mm)
MT-840/1	0.48	● Ø 6-25 ■ 0-25
MT-843	0.95	● Ø 6-35 ■ 0-35

Spool with earthing connection

Spool with cable and earth clamp.

IEC-61230

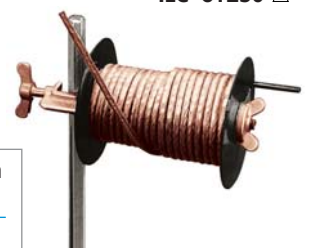

Reference	Silicone cable (mm ²)	Length (m)
MT-640-S	16	16
MT-641-S	16	25

Cables

Overhead line systems

Insulating sticks

Specific sticks and bags

Underground systems

Short-circuiting and earthing systems (mid-span horizontal configurations, work from ground)

Icc	Connecting cables	For conductors
8 kA/1s	35 mm ²	3-22 mm Ø

Installed from the ground on conductors up to 10.50 m.
Self locking contact clamp: powerful conductor clamping and very good performance at short-circuiting, does not slide.

PELICAN 2

- Easier installation features.
- More rigid metallic stick.
- Lower tube 30.6 mm dia.
- Upper tube 16 mm dia.
- Re-inforced insulated stick (36 mm dia.).
- Antisliding gripping area on the insulated stick: improves operator's grip.

Self locking clamp



Absence of spring increases reliability, facilitates cleaning and removal.

Used to check voltage absence beforehand



With a CC-375 IEC or CC-875 IEC series detector. Attached with a flag use contact electrode to one of the metallic stick.

Packaging

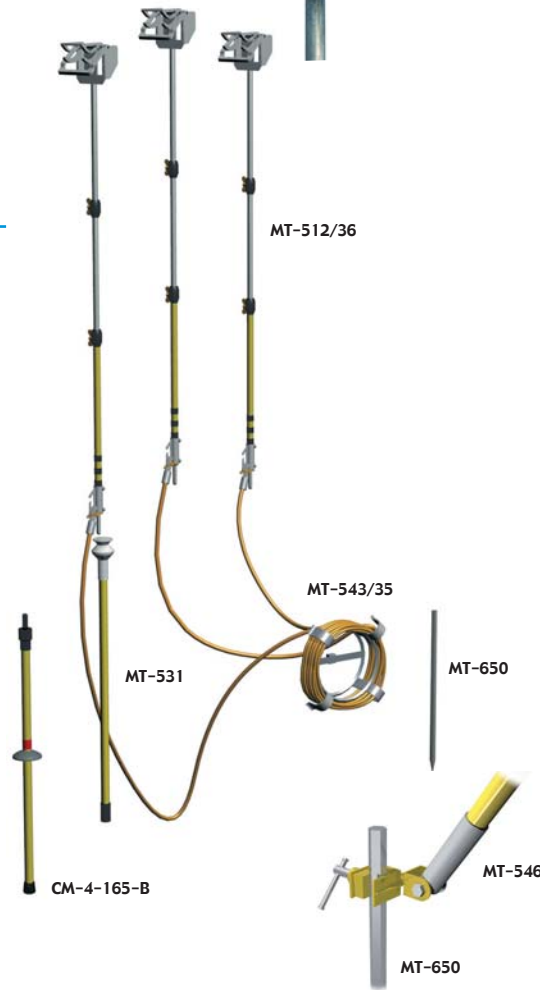

Equipment composition

Reference	Icc (kA/1s)	Composition
MT-508/36	8	3 telescopic metallic sticks 3 elements MT-512/36 - L = 6.00/2.37 m - 2.4 kg 1 insulated stick MT-531 2 elements 1.65 m Reel for 3 cables 10 m x 35 mm ² with earth connect. for attachment to stick - MT-543/35 1 earth rod 1 m MT-650 1 bag M-87127 : 2.50 x 0.30 x 0.15 - 10.5 kg
MT-508/46	8	3 telescopic metallic sticks 4 elements MT-512/46 - L = 5.10/1.62 m - 2.1 kg 1 insulated stick MT-531 2 elements 1.65 m 1 insulated intermediate stick element 1.65 m CM-4-165-B Reel for 3 cables 10 m x 35 mm ² with earth connect. for attachment to stick - MT-543/35 1 stick lifter MT-546 1 earth rod 1 m MT-650 1 bag M-87-208 : 1.70 x 0.30 x 0.20 m - 11.3 kg with separate parts: - cable reel 0.42 x 0.42 x 0.14 m - 13.2 kg - rod - 2.2 kg

Insulating sticks for short-circuiting and earthing systems

IEC-60855

These 39 mm dia. elements are assembled using a new safety bayonet system connector in aluminium alloy. They allow construction of a large variety of custom made sticks that meet the most varied conditions of application. Calibrated lengths of 1 to 3 meters (with fraction of 0.50 m) permit a huge number of applications.

This range thus allows a stick-length limitation in case of space requirements and carrying capabilities.

For common applications a serie of complete sets including 2 or 3 elements are made to give simple solutions for working distance from 2 to 6 meters.

Reference	Complete stick length (m)*	Complete stick length (m)**	Insulating length (m)	Weight (kg)
Basic elements				
CM-4410	1.13		0.7	1.25
CM-4415	1.63		1	1.70
CM-4420	2.13		1.2	2.70
CM-4425	2.63		1.5	3.20
Intermediate elements				
CM-4410-I	1.165		0.9	1.20
CM-4415-I	1.665		1.4	1.60
CM-4420-I	2.165		1.9	2.50
CM-4425-I	2.665		2.4	3.00
Terminal elements				
CM-4410-*	1.115	1.21	0.9-1	0.90
CM-4415-*	1.615	1.71	1.4-1.5	1.30
CM-4420-*	2.115	2.21	1.9-2	2.10
CM-4425-*	2.615	2.71	2.4-2.5	2.60
Intermediate elements with rain skirts				
CM-4400-J	0.36			0.95

* Add end piece C, K, E.

• With the smallest end fitting.
 •• With the biggest end fitting.

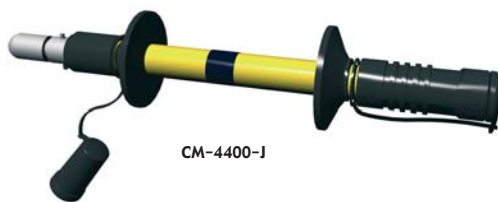

CM-4400-J

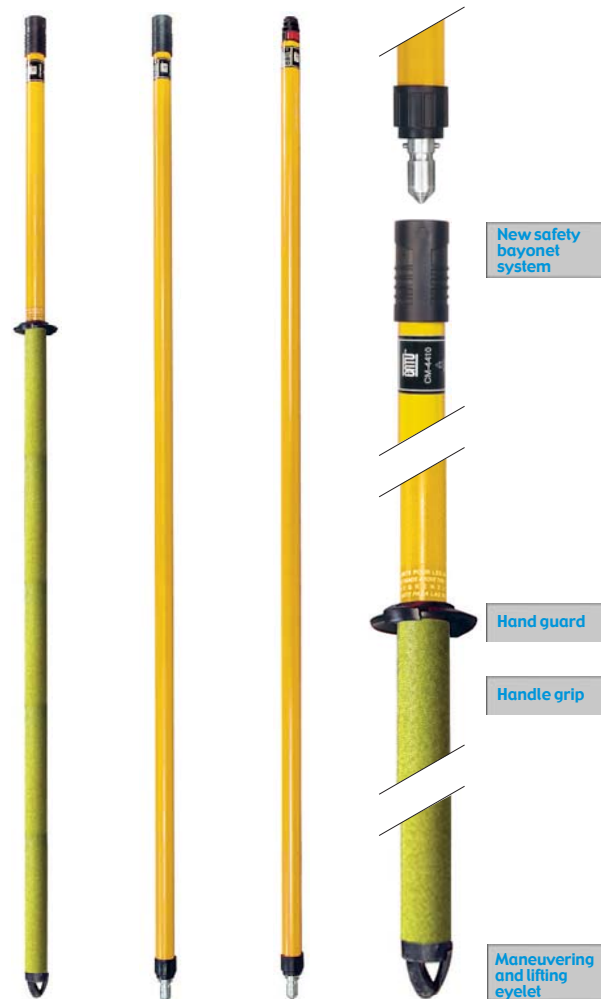

Sticks with rain skirts, C, K or E terminals

Epoxy reinforced fibre-glass insulating Ø 36 mm.
 Shock resisting polycarbonate rain skirts Ø 100 mm, height 90 mm.

CEI-61235

Reference	Length (m)	Rain skirt number	Weight (kg)
CF-5-40*	1.50	1	1.150
CF-5-90*	2.00	1	1.550

* Add end piece C, K, E.

Stick covers

Strong waterproof fabric, strap for carrying for CM-4 and CM-7.

Reference	Elements length (m)	Overall dimensions (m)
CM-3-03	1.75	0.575 x 1.950
CM-3-04	2.00	0.575 x 2.450
CM-3-05	2.50	0.575 x 2.950
CM-3-06	3.00	0.575 x 3.400



Cables

Overhead line systems

Insulating sticks

Specific sticks and bags

Underground systems

Clampsticks

For operations carried out on dead line networks.
Clamp stick for M.V. systems.
Cylindrical tubular rod Ø 32 mm in laminated epoxy glass fiber foam-filled.
Test voltage: 100 kV applied for 1 min, between alternate electrodes 30 cm away from one another.
Plastic control rod reinforced with glass fibre Ø 10 mm.
Rack-system operating handle, with 3 positions.
Suspension hook on the upper part.
Protective cap on the lower part.

Standard clampsticks

Reference	Length (m)	Weight (Kg)
MGS-100-S	2	2.8
MGS-103-S	3.80	4.3



MGS-103-S

Telescopic measuring stick

8 telescopic sections of insulated polyester glass, graduated and operated by a push-button mechanism.
Upper portion made of high voltage "live working tool" quality orange epoxy glass.
Direct reading at the top of the 1st section of the stick.
Max. length: 12 m
Folded length: 1.50 m - 3.3 kg.



MO-832

Max. length: 12 m - For use on L.V., M.V., H.V. lines 220 kV max.

Telescopic and disconnect telescopic sticks

Sections made of reinforced high density electrical grade fiber glass.
Top sections insulated with fire retardant polyurethane foam core.
Tip section: triply reinforced to eliminate breakages.
Universal head adaptable to standard fit or accessories, K end-pieces.
Test: 100 kV/30 cm - 5 minutes.

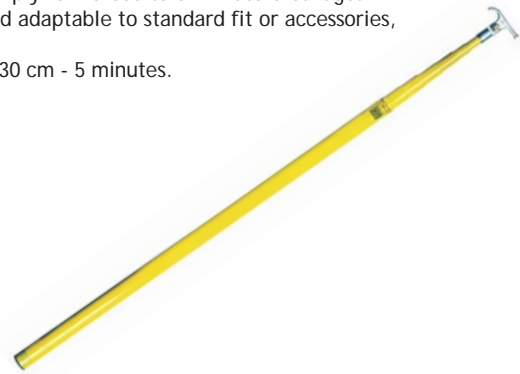

CE-5-50-(*)

Max. length: 5 m - Weight: 2.50 kg

CE-5-60-(*)

Max. length: 6 m - Weight: 3.00 kg

CE-5-70-(*)

Max. length: 7 m - Weight: 3.50 kg

CE-5-90-(*)

Max. length: 9 m - Weight: 4.00 kg

CE-5-105-(*)

Max. length: 10.50 m - Weight: 5.50 kg

* add the end-piece reference C or K.

Measuring stick

Consisting of 2 elements of epoxy resin and glass fiber composite material, 0.80 m thick, with alternating red and white 10 cm sections.



MG-208-K

Weight: 0.520 kg

Stick bags

Strong waterproof fabric, strap for carrying.



Reference	Max. stick length (m)
CM-1-10	1.20
CM-1-15	1.63
CM-1-20	2.20

Medium voltage

Short-circuiting and earthing systems for underground cables

Cable testing stick

Enables piercing of cable insulation and shielding, earthing up to 50 kV.
 Double bezel cutting blade - Capacity: 70 mm dia.
 Cable-guide with protecting guide.
 0.60 m insulating sleeve with 0.80 m extender.
 Ratchet type operating handle.
 Woven copper earth wire 70 mm² x 2.50 m with earth clamp.

MP-211 Total length: 1.60 m - Weight: 8.75 kg



Insulating blanket

Must be placed over the piercing point. 0.90 x 0.90 m with 50 mm Ø hole in the centre for inserting the sleeve.

MP-212 Dimensions: 0.9 x 0.9 m



For Railways and Urban Transport applications
 please ask for our specific catalogue

CATUTM
 Railway division

Connection adaptors for insulating sticks

	C	K	E	S	A or B							
	<p>hexagonal</p>	<p>universal</p>	<p>bayonet</p>	<p>clamp-stick</p>	<p>"MAJOR" Serie CM-4/CM-6/CM-7</p>							
Accessories	<p>C</p>		<p>K</p>		<p>E</p>							
Connection adaptors	<p>CI-7-C</p>	<p>CI-3-C</p>	<p>CI-6-C</p>	<p>CI-5-C</p>	<p>CI-3-K</p>	<p>CI-4-K</p>	<p>CI-6-K</p>	<p>CI-7-K</p>	<p>CI-5-K</p>	<p>CI-3-E</p>	<p>CI-7-E</p>	<p>CI-4-E</p>
Sticks	<p>E</p>	<p>AB</p>	<p>K</p>	<p>S</p>	<p>AB</p>	<p>C</p>	<p>K</p>	<p>E</p>	<p>S</p>	<p>AB</p>	<p>K</p>	<p>C</p>

With this range any accessory can be attached to any stick by using connection adaptors. Other models, please consult us.

Medium voltage

Sticks accessories

Tensioning equipment

Handling and uncoiling blocks

Manoeuvring hook



CM-02-C



CM-02-K

CM-02*

Bronze-copper nickel aluminium
Weight: 0.120 kg

* Add end-piece C, E or K.

Conductor brushes

Pivoting - 95 x 90 x 64 mm - Weight: 0.090 kg.



MG-206-AK

Moulded red colour body with card.
Reserved for aluminium conductors.

MG-206-CK

Moulded red colour body with card.
Reserved for copper conductors.

Pivoting - 110 x 110 x 70 mm - Weight: 0.250 kg.



MG-354



MG-352

MG-352-K

Moulded orange colour body with card.
Reserved for aluminium conductors.

MG-352-VK

Moulded green colour body with card.
Reserved for copper conductors.

MG-353-R

Orange spare brush for MG-353-V.
For hand brushing use.

MG-353-V

Green spare brush for MG-353-V.
For hand brushing use.

MG-354-K

Round brush - Ø 58 x 100 mm
Weight: 0.250 kg

MG-355

Spare brush for MG-354-K.

Diameter gauge

For conductors 3 to 16 mm Ø.
Entirely insulated material 270 x 35 x 12 mm.
Delivered in bag.



MD-535-K

Weight: 0.090 kg

Pig tail hook

Bronze end piece.
Spiral rod of corrosion-proof steel.



MG-207-K

K end-pieces steel - 120 x 65 x 60 mm
Weight: 0.210 kg

MG-207-S

S end-pieces steel - 250 x 65 x 60 mm
Weight: 0.280 kg

Cleaning brushes



MD-12-C



MD-10-C



MD-14-C

MD-10-C

Concave brush with two rows of
perpendicular bristles
100 x 125 x 170 mm - 0.500 kg

MD-12-C

Round head brush Ø 175 x 228 mm
0.500 kg

MD-14-C

Adjustable hinged round head brush
Ø 175 x 328 mm - 0.500 kg

Trimmer and pruning saw



MD-40-B



MD-42-B

MD-40-*

Trimmer, maximum capacity Ø 45 mm
(for branches up to 28 mm depending on
tree species) - 375 x 240 x 60 mm - 1.200 kg

MD-42-B

Pruning saw on rigid frame, 34 cm blade
125 x 610 x 60 mm - 1.100 kg

M-92-28

Replacement blade

* Add end-piece B or K.

Fuse puller

All parts in metal protected against
corrosion. Jaws sheathed with plastic.
Capacity : up to Ø 70 mm.



CM-04-K

Overall dimensions: 230 mm x 80 mm

Sticks accessories

Tensioning equipment

Handling and uncoiling blocks

Automatic come-along clamp

For non-insulated conductors: alloy, ACSR, alu, steel.

Characteristics

Steel body - mild bronze jaws.

Field on use

Overhead network.

Working method

Distance method.

Function use

The AUTOMATIC COME-ALONG CLAMPS are used to produce an anchoring on a line conductor in view of:

- moving it lengthwise
- locking it in position
- alternating its mechanical tension.



Reference	Ø (mm)		Max. working load (daN)	Jaws length (mm)	Max. length (mm)	Weight (kg)
	mini	max.				
MO-339/02	5.54	13.97	3636	127	400	2.84
MO-339/03	13.46	18.8	3636	140	450	3.52

Automatic come-along

For alu, alu alloy or ACSR.

Reference	Ø cable (mm)	Working load (daN)	Weight (kg)
MO-332/09-D	2.6-9.4	800	1.000
MO-332/14-D	6.4-14.3	1500	1.300
MO-332/13-E	5-13.2	2500	2.600
MO-332/18-E	12.7-18.8	3500	4.000
MO-332/22-E	17-22.5	3500	4.000



Insulated cables.

Reference	Ø cable (mm)	Working load (daN)	Weight (kg)
MO-331/13-P	6-13.5	600	1.000
MO-331/22-P	17-22	400	1.000
MO-331/38-P	33-38	800	3.775



Come-along

Not suitable for alu conductors.



Reference	Clamping capacity Ø (mm)	Weight (kg)
MO-337/06	1-8	0.300

Adjustment "Come-along"

Tightening by cam jaw.

For copper and aluminium conductors.



Reference	Clamping capacity Ø (mm)	Weight (kg)
MK-08	2-18	0.300
MK-15	7-15	0.550
MK-20	14-18	0.600

“TIRFOR” and “JOCKEY” winches

System traction produced by jaws which reproduces movement of hands pulling on cord, thus making it possible to enter an unlimited cable length.



Reference	Type	Maximum force (daN)**	Requirements (cm)	Weight without cable (kg)	Cable weight (kg)
ML-05/10	Jockey J-5	500	31 x 21.5 x 5.5	4	2.5
ML-08/20*	T-508	800	42 x 25 x 9.9	6.6	7
ML-16/20*	T-516	1 600	53 x 31.5 x 12.7	13.5	12.5
ML-32/20*	T-532	3 200	63.1 x 35.7 x 14.8	24	26

*Equipment delivered with 20 m cable equipped with hook.

**The first number indicates the maximum authorized lifting load.

“TIRVIT” mechanical adjusters

The conductor to be adjusted is directly clamped between two cam jaws which alternately approach and move away from each other by lever manoeuvring. Very simple, sturdy and reliable, the Tirvit is the ideal apparatus for tightening up small and medium section lines. It is equipped with a chain and handle for fixed anchoring.



Reference	Force (daN)	Clamping capacity Ø (mm)	Total - Length (m) - lever		Weight (kg)
MK-40	400	2-8	0.680	0.540	4.000
MK-60	600	7-15	0.780	0.630	5.200
MK-100	1 000	14-18	0.875	0.700	6.200

Parallel jaws “Come-along”

Reference	Conductor size		Safe load (daN)	Weight (kg)
	Ø (mm)	section (mm ²)		
MO-331/06-A	8.5	25-35	1 000	0.800
MO-331/09-A	12	50-70	1 700	1.100
MO-331/12-A	16	95-120	3 000	1.800
MO-331/04-B	1-4	1-16	500	0.270
MO-331/08-B	3-8	6-35	1 000	0.800
MO-331/10-B	5-10	16-70	1 700	1.100
MO-331/16-B	8-16	50-150	3 000	1.900
MO-331/26-B	8-26	90-400	4 000	3.700
MO-331/13-P	For insulated cable. Capacity Ø 3.5 to 14 mm - 800 daN			

For bare cables (material: forged steel).
References are followed by the index A or B to indicate:
A - Suitable for use with aluminium conductors (including all aluminium alloys),
B - Suitable for use with copper or steel conductors.



Uncoiling block

For bare cables.
Made entirely from aluminium alloy.
Pivoting safety hook. Full wheel rigger.
Ring with greaser.
Safety catch.

For insulated cables.
Single piece body made of aluminium alloy. Nylon strap (length 1.5 m) firmly attached to the body equipped with automatic ratchet tightener.
Maximum load of use: F1: 800 daN, F2: 400 daN, F3: 120 daN.

Reference	Utilisation	Groove bottom diameter (mm)	Capacity (mm)	Maximum load (daN)	Hook capacity (mm)	Weight (kg)
MO-375/150	Bare cables	160	22	1 000	25	1.55
MO-375/250	Bare cables	250	38	1 000	25	2.1
MO-375/300	Bare cables	300	36	1 500	25	2.85
MO-375/400	Bare cables	400	80	2 000	NC*	15.0
MO-375/600	Bare cables	600	80	3 000	NC*	24.5
MO-375/800	Bare cables	800	100	5 000	NC*	35.5
MO-371/01	Insulated cables	140	80	800	24	1.5
MO-371/100	Bracket with strap for MO-371/01		-	800	-	2.2

* NC : not communicated.



MO-375/...

MO-371/100



MO-371/01

Opening block

For elevation handling, single block and tackle and return block.
Can also be used as uncoiling block.
Aluminium alloy - block assembled on needle bearings.
Block Ø at groove bottom: 114 mm.
Maximum rope Ø: 16 mm.
Permissible load on rope strands: 250 daN.
Hook opening: 33 mm.

MO-308 Weight: 3 kg

For other models, please consult us.



Ratchet lift-chain hoists

Precise: 1.3 to 0.3 mm travel.
Aluminium alloy body and lever.
360° short lever used without large effort.
Chain can enter from all angles.
Three position selector:
up - down - free chain.
Safety factor > 5.



Reference	Maximum lifting load (kg)	Overall width (mm)	Weight (kg)	
			run 1.50 m	run 5.00 m
MO-431/07	750	84	7.00	-
MO-435/07	750	84	-	10.35
MO-431/15	1 500	108	11.00	-
MO-435/15	1 500	108	-	15.80
MO-431/30	3 000	115	20.00	-

Guying equipment

Used whenever pole stability is doubtful. Hinged jaw device installed, from the ground, at a 6 to 8 m height using connectable rods. Guy wires fixed on jaws and staked to the ground by rods ensure pole stability. Forged hot galvanised steel jaws, test load: 1 000 daN. Control rod 6 m in elements of 1.20 m, aluminium alloy. Set of ropes: 3 guy wires 11 or 15 m + a strap with centre ring - with heart shaped thimble and snaps. 3 steel anchoring rods, 1 m.

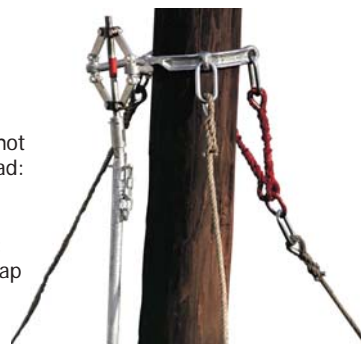

MP-315

Guying equipment with 15 m guy wires in metallic box 480 x 340 x 200 mm and control rod + rods with carrying belt - 26.5 kg

MP-311

Guying equipment with 11 m guy wires in metallic box 480 x 340 x 200 mm and control rod + rods - 22 kg

The rod is, in most cases, the most practical, effective and reliable earth connection means.

Highly effective: for a given contact surface area, the linear type electrode provides, both theoretically and practically, the least earth resistance. Furthermore, it enables the most moist and conductive layers to be reached.

Easy and quick to install, it requires no earth work. Even inside industrial buildings, it is often possible to install an earth rod exactly where required by breaking through a small area of the floor.

Accessible and testable connection: the use of an inspection box makes it possible to leave the head of the rod and its connection unburied and to periodically test it and measure its resistance.

Self connectable rods

The lower end of each rod is equipped with a point used both for driving into the earth and for connection; the upper pierced end receives (without the sleeve) the point of the previous rod. Use a rivetting head so as not to damage the upper end when driving in.

Connectable rods

Conical slide-in provides perfect assembly stability. For deep earth connections.

Copper/steel (350 µm coating) earth rods

Reference	Type	Ø (mm)	Length (m)	Weight (kg)	Connection
TP-1610-R	standard (1)	14.2 Unit 16	1.0	1.200	
TP-1615-R	standard (1)	14.2 Unit 16	1.5	1.800	
TP-1620-R	standard (1)	14.2 Unit 16	2.0	2.400	
TP-1910-R	standard	17.3 Unit 19	1.0	2.000	
TP-1915-R	standard	17.3 Unit 19	1.5	2.800	
TP-1920-R	standard	17.3 Unit 19	2.0	3.600	
TR-116-10	self connectable	14.2 Unit 16	1.0	1.100	TO-3-16/19
TR-116-15	self connectable	14.2 Unit 16	1.5	2.000	TO-2-16 TS-1601
TR-119-10	self connectable	17.3 Unit 19	1.0	1.800	TO-3-16/19
TR-119-15	self connectable	17.3 Unit 19	1.5	2.750	TO-2-19 TS-1901
TR-119-20	self connectable	17.3 Unit 19	2.0	3.500	
TR-1610	connectable (2)	14.2 Unit 16	1.0	1.250	TO-3-16/19
TR-1615	connectable (2)	14.2 Unit 16	1.5	1.900	TO-2-16 TS-1601
TR-1620	connectable (2)	14.2 Unit 16	2.0	2.500	TS-1602 TS-1603
TR-1910	connectable (2)	17.3 Unit 19	1.0	1.950	TO-3-16/19
TR-1915	connectable (2)	17.3 Unit 19	1.5	1.850	TO-2-19
TR-1920	connectable (2)	17.3 Unit 19	2.0	3.750	TS-1901
					TS-1902 TS-1903



- (1) Delivered completed with connection.
- (2) Sleeves and spikes have to be ordered separately.



Connectors

Reference	Rod Ø max. (mm)	Conductors section max. (mm²)	Type
TO-2-16	16	40	Copper
TO-2-19	19	40	
TO-3-16/19	19	40	Copper aluminium alloy
TS-1601	14	95	Copper aluminium alloy
TS-1901	19	95	

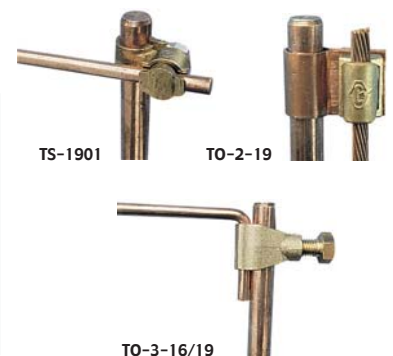

Earth rods

Connectors

Earthing clip

Earth tester

Earthing clip

Interconnects to earth every metallic part of installations.

Reference	Conductors section (mm ²)	Crimping capacity on pipe (Ø mm)
COL-8/32	1 x 2.5 to 2 x 6	8-32
COL-32/100	1 x 2.5 to 2 x 16	32-100



MX-430-M earth tester

The MX-430-M allows for the measurement of earth resistance and earth specific resistivity and also the spurious voltages caused by grounding parasitic voltage presence.

This equipment is suitable for fast and easy measurement of the grounding resistance in home, industrial buildings, substations,...

- Wide range of measurement from 0.01 Ω to 20 KΩ
- High visibility 3 1/2 digit display with direct readings, even under sunlight
- Supplied with a rechargeable internal battery. A smart charger is microprocessor-controlled and can be powered from the mains by a power plug provided source or from a 12 V car battery.

Technical features

- Application: measurement of grounding resistances (with 3 earth rods), earth resistivity (with 4 earth rods) and spurious voltage presence
- Range of measurement: 0 - 20 Ω; 0-200 Ω; 0-2000 Ω and 20 KΩ
- Voltmeter: voltmeter function in AC range as a conventional voltmeter 0-200 V AC
- Operation frequency: 1470 Hz
- Current in and out put power: less than 0,5 W and the out put current is limited to less than 15 mA (peak to peak)
- Operation temperature: -10°C / +50°C
- Storage temperature: -25°C / +65°C
- Humidity: 95% RH (without condemnation)
- Accessories included:
 - Connection wire to supply the charger with a 12 V battery
 - Battery charger 220-240 V
 - Storage bag



MX-430-M 221 x 189 x 99 mm - Weight: 2 kg

Accessories (measurement kit) MX-433-T

- 1 storage bag
- 4 earth rods copper plated steel
- 1 x 5 meters black cable
- 1 x 40 meters red cable
- 2 x 20 meters cable (1 blue and 1 green)
- 1 x 5 meters green cable to connect to the grounding system
- 1 hammer

MX-433-T 570 x 220 x 160 mm - Weight: 7.7 kg



LIVE WORKING TOOLS



Since the second world war, CATU has worked in close co-operation with EDF to research and develop safety equipment and practices for use on low and high voltage networks, initially in France and now worldwide.

Utilities would be better off efficiency of their networks by avoiding outages, whatever the costs. With the increasing recognition of EDF-Serect worldwide, CATU is fast becoming a major supplier in liveline working equipment. All the tools meet the specifications of the International Electrotechnical Committee (IEC).

CATU tools have a liveline life of around 20 years.

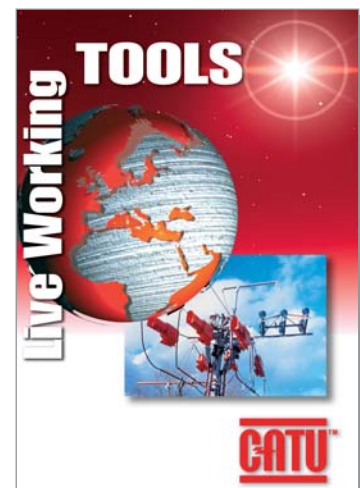

Catalogue available upon request.

High voltage



Above 52kV

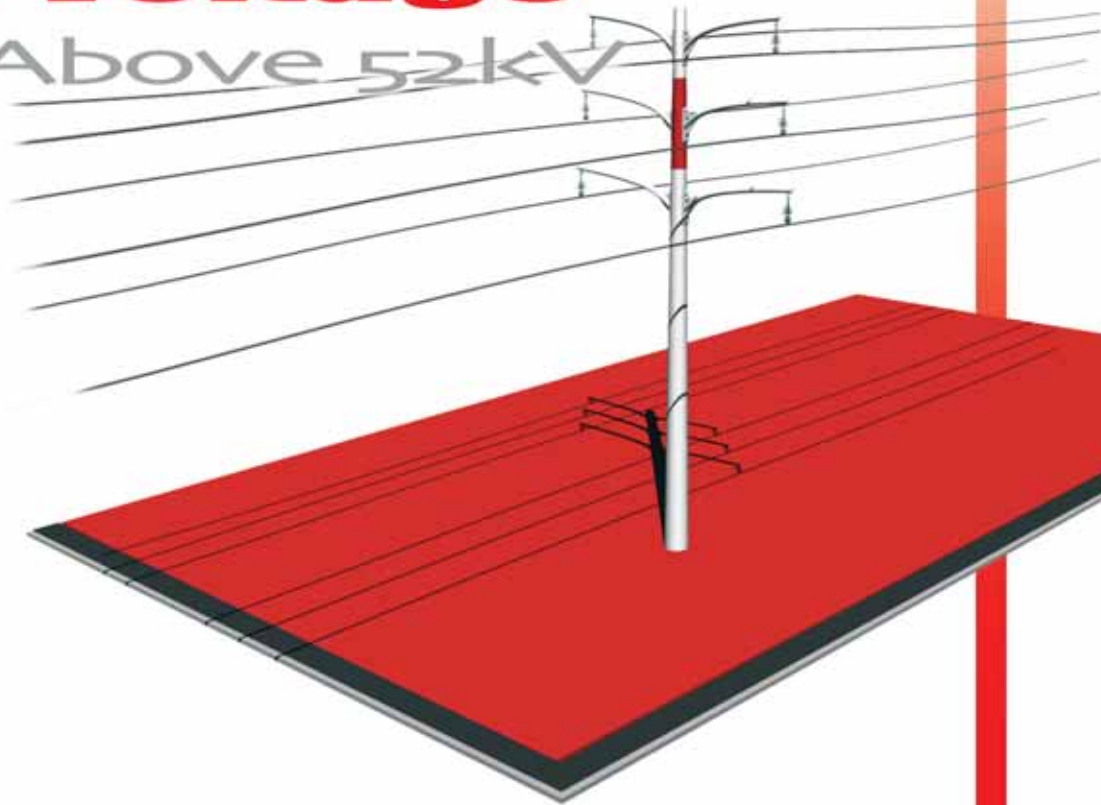

Equipment guide

100

Personal protective equipment

102

Safety padlocks and warning signs

110

Voltage detectors

113

Short-circuiting and earthing systems

115

High voltage

Examples of usual applications

Overhead line (work from pole)

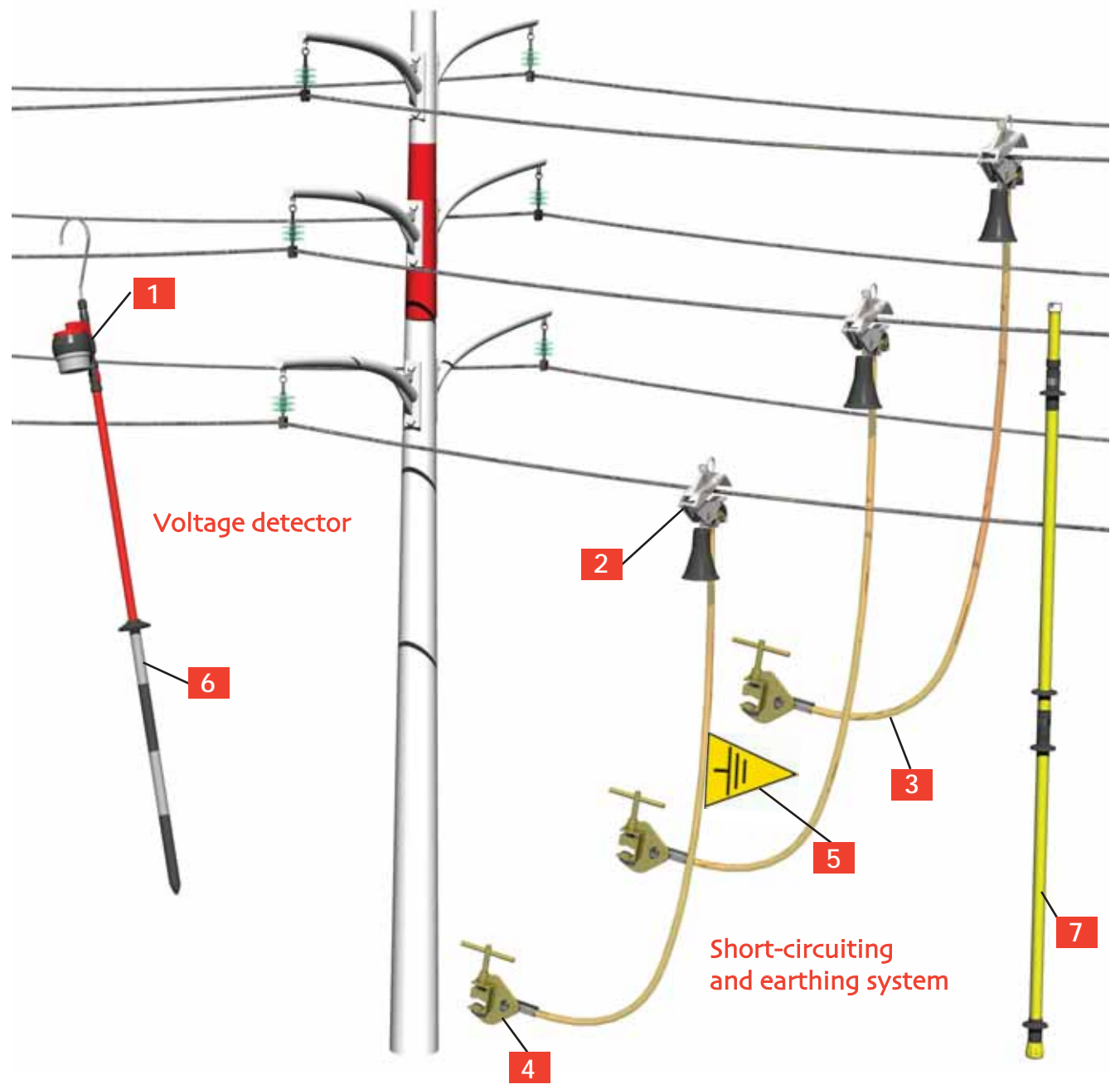

High voltage

Voltage detectors

1	Electronic voltage detectors IEC or standard	References: CC-245 serie	Page: 113
----------	--	--------------------------	-----------

Short-circuiting Systems

2	Clamps manoeuvrable by insulating sticks	References: MT-730 serie	Page: 115
3	Cables (copper)	References: M-24-... series	Page: 117

Before intervention select the right personal protective equipment

Substation line (work from ground)

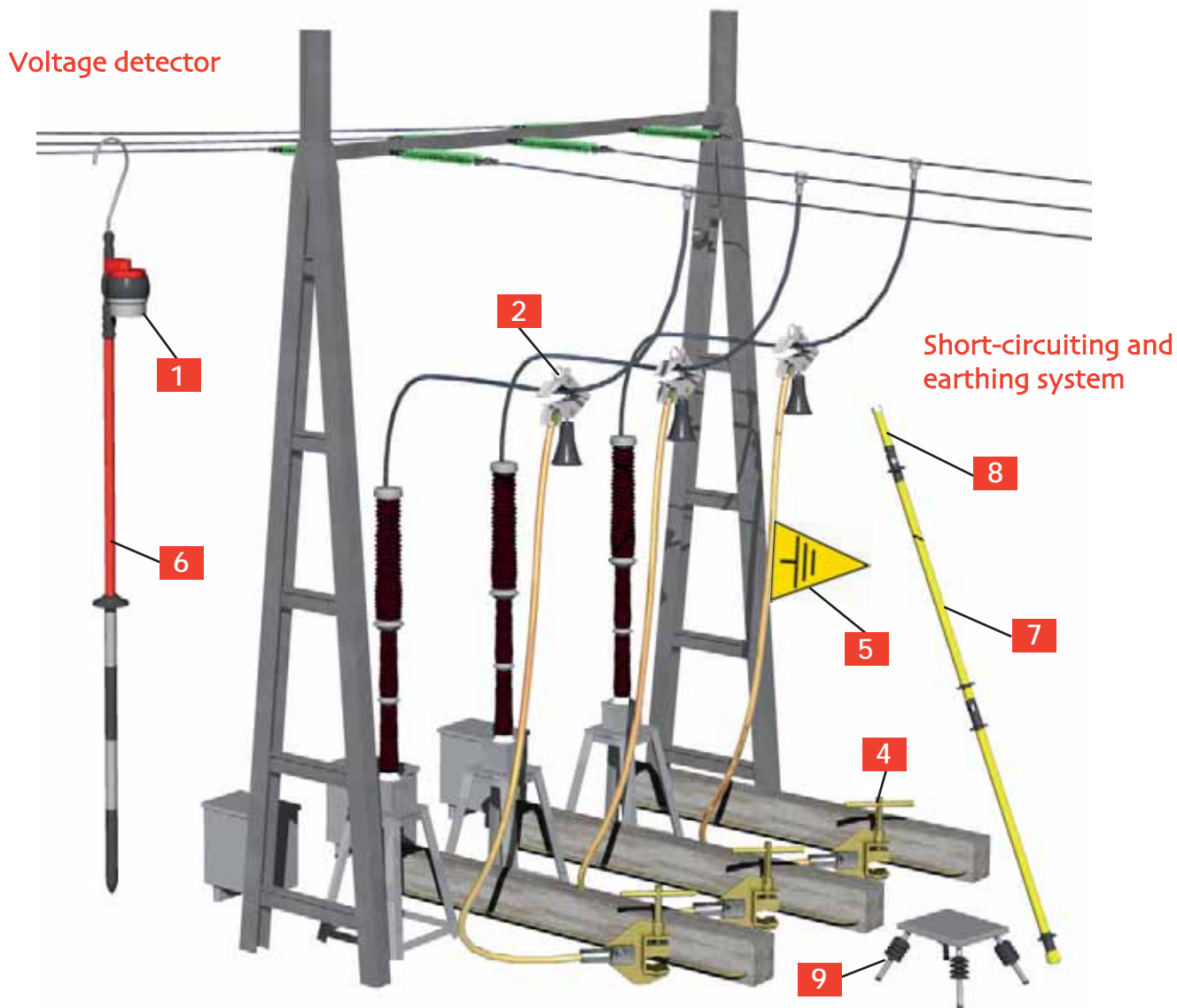

Earth Clamps and flags

4	Earth Clamps	References: MT-847, MT-843	Page: 116
5	Earth Flags	References: AL-58, AL-60	Page: 112

insulating sticks

6	Insulating Sticks IEC For short-circuiting systems and Voltage detectors	References: CM-4000 serie	Page: 114
7	Insulating sticks for short circuiting and earthing system	References: CM-6 serie	Page: 116
8	Connection adaptors	References: CI... serie	Page: 115

insulating platform

9	Insulating platform outdoor use	References: CT-9-63	Page: 105
----------	---------------------------------	---------------------	-----------

Safety glasses

Protection against UV radiation and ejections of solid particles. Grilamid frame in orange Softflex. Anti-scratch, anti-impact and anti-chemical product treatments. Caution: Do not use for welding operations.

EN 166/EN 170
CE



- MO-11000** Clear lenses, delivered in pouch
- MO-11001** Tinted lenses, delivered in pouch

Overglasses

Polycarbonate overglasses. Protection against UV radiation and ejections of solid particles. Caution: Do not use for welding operations.

EN 166/EN 170
CE



- MO-11010** Clear lenses
- MO-11011** Green tinted lenses

ABS helmet

Electrically insulating helmets for use on low voltage installations. Safety industrial helmet, safety helmet for electrical use, especially designed to maximize wearer's comfort. Standard sizes 53 to 63. Leather trim 21 cm along the inside for added comfort. Multiple adjustments for a perfect fit - headband: adjustable in 3 mm increments. Built-in cushion for optimum ventilation. Safety chin strap: fastenings to shell tear resistant. Weight: 0.300 kg.

EN 397
EN 50365 Δ
ANSI Z89.1:2003
Class E 20 kV
CE



- MO-182/1-B** White
- MO-182/1-R** Red

Face shield

Face shield adjustable on MO -182 helmet. 100% UV protection. Weight: 0.170 kg. Caution: Do not use for welding operations.

EN 166/EN 170
CE



- MO-184** Single size, adjustable by rubber band

Helmet with built-in face shield

Panoramic face shield in non-scratch and anti-mist polycarbonate. Chinstrap (with Velcro fastening) Head fit adjustment by milled wheel. Single size: 0.270 kg.

EN 166/EN 170/EN 397
EN 50365 Δ
CE



- MO-185-BL** White
- MO-185-R** Red
- MO-185-J** Yellow
- MO-185-B** Blue
- M-881622** Spare face shield for MO-185

Polycarbonate helmet

Polycarbonate helmet. Shock and wear resisting, comfortable. Adjustable size from 53 to 63 cm. Weight: 0,465 Kg.

EN 397
CE



- MO-183-BL** White, single size, adjustable
- MO-183-RL** Red, single size, adjustable

Headlamp with adjustable focus

Can be carried either on the head or any type of helmet.
Lighting control and beam by switches.
Range: 30 meters.
Adjustable lamp height angle.
Sealed against rain.
Powered by 4 batteries LR 6.
Autonomy: 6 hours.
Standard bulb 4.8 V/0.3 A.



LED's Headlamp (3 LED's)

Can be carried either on the head or any kind of helmet.
- Lighting by 3 high performance LEDs.
- 3 lighting levels.
- Adjustable lamp height angle.
- Very light, waterproof IP65.
- Range: 10 to 15 meters.
- Powered by 3 batteries LR03 (AAA).
- Autonomy: 80 hours.



MS-118

Headlamp - Weight: 0.187 kg

M-95-865

Halogen bulb (sold by set of 5 units)
5.2 V 0.5 A

M-95-864

Hooks set for helmet

MS-121

Delivered with batteries and a carrying bag
Weight: 0.09 Kg

M-95-864

Hooks set for helmet

LED's headlamp (5 LED's)

LED's Headlamp (5 LED's).
Can be carried on the head or any kind of helmet.
Lighting by 5 high performance white new generation LED's - 3 lighting levels + 1 flash mode + 1 red lighting.
IPX6.
Powered by four batteries LR06 (AA).
Range : 30 meters.
Autonomy : 100 hours.



MS-127

Delivered with batteries and a carrying bag
Weight: 226 g

M-95-864

Hooks set for helmet

Intrinsically safe ATEX LED's Headlamp

II 2GD EEx ia IIC T4
Can be carried either on the head or any kind of helmet.
- Lighting by 3 high performance White LEDs.
- 2 lighting levels (High: 3 LEDs on or low: 1 LED on).
- Adjustable lamp height angle.
- Very light, ABS body.
- ATEX certified Categorie 2 (Zone 1)
N° TRL03ATEX21005X.
- Range: 10 to 15 meters.
- Powered by 3 batteries LR03 (AAA).
- Autonomy: 150 hours.
- Strap: cloth or silicone rubber (for helmet).



MS-126

Delivered with batteries - Weight: 0,125Kg

M-95-864

Hooks set for helmet

Insulating rubber gloves

Insulating rubber gloves conform to international IEC-60903 standard. To satisfy the requirements of this standard, they are subjected to dielectrical, mechanical resistance and ageing tests. The acceptance levels for mechanical tests are stricter. The tests are especially aimed at checking the tensile strength and elongation at break, the mechanical puncture test and tension set. Our gloves are made of latex especially treated to obtain high dielectric characteristics; they are individually tested and delivered in sealed plastic bags.



IEC-60903

Reference	Class	Voltage (V)	Thickness (mm)	Designation	Weight (g)
CG-30 (*)	3	26500	2.9	latex	560
CG-30 (*)-AM	3	26500	2.7	Two colors latex rolled edge	530
CG-40 (**)	4	36000	3.6	latex	800
CG-40 (**)-AM	4	36000	3	Two colors latex rolled edge	650

* References to be completed by size B or C. Correspondence with standard sizes: B = 9, C = 10, D = 11.
 ** References to be completed by size C or D.

Pneumatic glove tester

For compulsory control of gloves before use. Checking is done by inflating and immersing in water.



CG-117 140 x 150 x 160 mm - Weight: 0.600 kg

Undergloves

Cotton undergloves To be used with insulating rubber gloves.



CG-80 ()** ** H: men / F: women

Rubber gloves storage box with window

To be placed in high voltage stations. Insulating material, shock resistant, yellow colour. Transparent window (enables to check gloves presence). Bottle of talc included. Attachment: 4 holes 3.5 mm dia., centre distances 155 x 345 mm. U.V. protection window.



CG-35/1 60 x 210 x 460 mm - Weight: 0.730 kg

Overgloves

Used as outer glove. Silicon grain leather, very flexible. Large protective cuff in chrome tanned hide. Adhesive strap.



EN 388

CG-99 (*) Weight: 0.170 kg * Add size: C, D

Carrying bag

Made from reinforced waterproof fabric for transport of rubber gloves in vehicles and tool boxes. Rear loop for belt and snaps.



CG-36 60 x 180 x 400 mm - Weight: 0.120 kg

Working gloves

Handling leather and cotton gloves. Docker type.



EN 388

CG-97-C Single size (C = 10)

Head and eyes protection

Insulating rubber gloves

Insulating mats and boots

Equipment for working on pole

Insulating mats

The matting is manufactured of elastomer compounds with slip-resistant surface. High quality dielectrical rubber.



Reference	Thickness (mm)	Dimensions (m)
MP-60/10-5	10	0.6 x 5
MP-60/10-10	10	0.6 x 10
MP-100/10-5	10	1 x 5
MP-100/10-10	10	1 x 10

Insulating platform (outdoor model)

Solid plate with moulded insulating material 52 x 52 cm, thickness 40 cm. Feet with rubber tips.



Reference	Rated insulation (V)	Number of skirts per foot	Height (mm)	Weight (kg)
CT-9-63	63 000	4	515	7.00

Rescue sticks

Insulating sticks ended by a large hook in order to rescue quickly an electrified victim in case of accident.



CS-90*	Length: 2.05 m - Rated insulation: 90 kV
CS-225*	Length: 2.45 m - Rated insulation: 225 kV

* Delivered with wall mounted supports.

Insulating platform (indoor model)

Solid plate with moulded insulating material 52 x 52 cm, thickness 40 cm. Feet with rubber tips.



Reference	Rated insulation (V)	Height (mm)	Weight (kg)
CT-7-63	63 000	340	3.35

Head and eyes protection

Insulating rubber gloves

Insulating mats and platforms

Equipment for working on pole

High voltage

Pro electric full body fall arrest harness

2 fall arrest attachment point: dorsal and sternal. Automatic buckles of the belt and leg loops. Elastic shoulder straps. Padded leg loops. A work positioning belt, with a comfortable and lightweight pad. 2 buckles of work positioning Belt. Leg loops and shoulder straps adjustable. Polyamide straps. Tools holders. 3 sizes : S, M, XL. Delivered in a protective bag with a users manual. Weight: 2.7 kg.



EN 358
EN 361
CE

MO-563(*) * add size: S/M/XL
S = small M = medium XL = large

Pro electric full body fall arrest harness

4 fall arrest attachment point : one dorsal point, two sternal points by two metallic D rings, a sternal point by strap. A ventral attachment point for a descender and / or lanyard. Automatic buckles of leg loops. Padded leg loops. A work positioning belt, with a comfortable and lightweight pad. 2 buckles of work positioning Belt. Leg loops and shoulder straps adjustable. Polyamide straps. Tools holders. 3 sizes : S, M, XL. Delivered in a protective bag with a users manual. Weight: 2.9 kg.



EN 358
EN 361
EN 813
CE

MO-564(*) * add size: S/M/XL
S = small M = medium XL = large

Full body fall arrest harness

2 fall arrest attachment point : dorsal and sternal. A work positioning belt, with a comfortable and lightweight pad. 2 buckles of work positioning Belt. Leg loops and shoulder straps adjustable. Polyamide straps. Unique size. Delivered in a protective bag.



EN 358
EN 361
CE

MO-71 Weight: 1.9 kg

Equipped rope straps with lever stretcher

Equipped with adjuster. Hooks to belt with rapid link.



EN 358
CE

MO-52-L Length: 4 m - Weight: 1 kg

Anti-fall grip

The safety block runs freely on its rope but can be automatically locked in case of a sudden downward drop. Must be used only with special 15 mm Ø rope delivered with the device.



EN 353-3
CE

MO-68/10 With 10 m of rope - Weight: 2.300 kg
MO-68/15 With 15 m of rope - Weight: 3.250 kg

Double safety descent device

Articulated stainless steel cam. Aluminium housing. High-resistance handle. Operates with 9-12 mm diameter lanyard. Ideal for evacuation. Lets you regulate descent.



EN 361
CE

MD-02 Weight: 0.32 Kg

Tether rope with energy absorber

Tether rope in polyamide Ø14 mm.



EN 355
CE

MO-52020 Length: 1.50 m
MO-52021 Length: 2.00 m

Double tether rope with energy absorber

Double tether rope with energy absorber Equipped with 2 steel snap hooks with automatic locking and 1 steel snap hook with screwing locking



EN 355
CE

MO-54010 Length: 1.20 m - Weight: 1.4 kg

Head and eyes protection

Insulating rubber gloves

Insulating mats and platforms

Equipment for working on pole

Snap hooks (stainless steel)



MO-54

EN 362
CE

MO-54

Locks with threaded ring - Opening: 15 mm
100 x 58 mm - 0.154 kg



MO-55/1

EN 362
CE

MO-55/1

Locking by screwing ring on a spring loaded mobile catch; an additional catch is provided to prevent the rope from slipping in the carabiner - 155 x 75 mm - 0.140 kg

Snap hooks (aluminium alloy) zical



MO-54000

EN 362

MO-54000

Oval snap hook - Opening: 15 mm
Individually tested - Weight: 0.071 kg
110 x 58 mm



MO-54004

CE

MO-54004

D-shaped snap hook with automatic locking
Opening: 23 mm - Individually tested
Weight: 0.087 kg - 120 x 72 mm

Fall arrester - retractable type

Designed for lineman safety. Quick acceleration causes instant locking. Corrosion protected steel shell. Integrated braking mechanism and dissipating element. Self locking mechanism and automatic tensioning and return facility. Galvanized cable Ø 4 mm. Strength: 1 200 daN. Delivered with a screw crab. Max. length: 10 m.



EN 360

MO-591002

Weight: 7.00 kg

Snap hook with double safety latch



EN 362
CE

Opening: 50 mm
Body in steel
Fingers in stainless steel
Resistance: 20 kN.

MO-54002

Weight: 0.390 Kg

Tether rope equipped with a tension device

The tether rope is intended to ensure that operators are held in position when working at a height. This tether rope must be associated with a harness belt. Ends sewn to form an attachment and protected with a plastic girdle. Static resistance: 15 kN. Polyamide Ø 15 mm.



EN 358
CE

MO-56009

Weight: 1.425 kg - Length: 3 m

MO-56010

Weight: 1.600 kg - Length: 5 m

Safety rope with wear tell tales

Rope: 14 PEPT multi-filament (15 mm diam.)
Two-colour safety rope, 100% polyester made of 3 white strands with black central thread (wear telltale).
Buckle: Polyamide central lug attaches to snap-hook of belt.



EN 354
CE

MO-052

Safety rope only - Length: 4 m - 0.76 kg

Lanyard

Synthetic fibre ropes - 10 mm.
Loops spliced at both ends.
Delivered without snap hook.



EN 354
CE

MO-53

Length: 1.50 m - Weight: 0.125 kg

Anti fall device with automatic release strap

Winder with self-locking strap.
Length: 2 m.
Equipped with shock absorber.
Allows 2 m of movement autonomy around anchoring point.

EN 360



MO-591000 Weight: 1.160 kg

Constraint tie

Tie in polyamide.

EN 795
CE



MO-52031	Length: 0.8 m - Weight: 0.100 kg
MO-52033	Length: 1.20 m - Weight: 0.135 kg
MO-52034	Length: 1.50 m - Weight: 0.150 kg

Working on pole kit



Reference	Use
KIT-HAUT-01-(*)	To go up a pole with insulating ladders
KIT-HAUT-02-(*)	To go up a pole with spliced ladders
KIT-HAUT-03-(*)	To go up a catenary
KIT-HAUT-04-(*)	To go up on a pylon
KIT-HAUT-05-(*)	To go up on a roof
KIT-HAUT-06-(*)	To go up using a nacelle

Composition	KIT-HAUT-					
	01-(*)	02-(*)	03-(*)	04-(*)	05-(*)	06-(*)
Harness MO-563	■	■	■			
Harness MO-564				■		
Harness MO-71					■	■
Tether rope MO-52020	■					■
Double tether rope MO-54010		■		■	■	
Constraint tie MO-52034	■	■				
Constraint tie MO-52031				■(2)		
Tether rope with tension device MO-56009	■	■	■	■	■	
Anti-fall grip MO-68/15	■	■	■	■		
Snap hook MO-54	■	■				
Carrying bag M-87-295	■	■	■	■	■	■

(*) add size : M or XL
order example : KIT-HAUT-02-XL.

Head and eyes protection

Insulating rubber gloves

Insulating mats and platforms

Equipment for working on pole

Insulating ladders

A complete range with top quality features: Insulation between two steps: 30000 V (test performed after immersion in water for 24 hours). High mechanical resistance to bending and twisting. Good resistance/weight ratio. High fire resistance. High resistance against bad weather and corrosive elements. Lateral risers in polyester/glass fiber rectangular section 70 x 25 mm. Aluminium alloy rungs with square 29 x 29 mm section and anti-slip coating.



EN 131
CE

Insulating 2 section extension ladders, hand operated

Reference	Folded length	Extended length	Number of rungs	Weight (kg)
MP-514/2	2.41 (m)	4.09 (m)	2 x 8	13.9
MP-515/2	2.97 (m)	5.21 (m)	2 x 10	17

MP-506...

MP-514...

Insulating 2 section extension ladders, rope and pulley operated

MP-506/2	3.53 (m)	6.05 (m)	2 x 12	20
MP-508/2	4.66 (m)	8.30 (m)	2 x 16	31
MP-510/2	5.78 (m)	10.26 (m)	2 x 20	38

Services

- Technical assistance
- Training
- Flexible workshop

Ask our specialist

+33 1 42 31 46 24

philippe.monteillet@catuelec.com

High voltage

Padlocks with warning signs

Brass ring bow 50 or 70 mm.
Diameter of the ring bow
4 or 6 mm.



Reference	Ring bow (mm)	Ø (mm)	Weight (kg)
AL-230-(*)-EX	50	6	0.170
AL-230-S-(*)-EX	70	6	0.190
AL-230-Z-EX	50	6	0.170
AL-230-S-Z-EX	70	6	0.190
AL-240-(*)-EX	50	4	0.170
AL-240-S-(*)-EX	70	4	0.190
AL-240-Z-EX	50	4	0.170
AL-240-S-Z-EX	70	4	0.190

* Add n° of key: 111 or 222
"00" n° standard key: n° of key upon request
Z: random n° of key

Marking

For indelible writing on the warning signs and padlocks, our ALU-SCRIPT™ markers are ideal.



AS-404	4 markers in assorted colours (red, black, blue and green)
--------	--

Safety locking badge

Fit with multiple locking apparatus AL-202
White letters on red aluminium
Fixing with 1 hole Ø 10 mm.



AM-467-GB	Ø 80 mm
-----------	---------

Handle with 6 padlocks

Handle of moulded plastic for holding up to six padlocks.
Compartment with transparent cover for key storage.



Reference	Weight (kg)	Handle with 6 padlocks
AL-236-111-EX	1.150	AL-230-111-EX
AL-236-S-111-EX	1.210	AL-230-S-111-E
AL-236-222-EX	1.150	AL-230-222-EX
AL-236-S-222-EX	1.210	AL-230-S-222-EX

Multiple locking apparatus

Holds up to four padlocks and a sign.



AL-200



AL-202

AL-200	100 x 60 x 10 mm - Weight: 0.150 kg
AL-202	165 x 50 x 12 mm - Weight: 0.200 kg

Handle for 10 and 30 padlocks

PVC.
Shock resistant.
Ivory colour.
With holes Ø 9 mm.



AL-207/10	For 10 padlocks - Weight: 0.06 kg
AL-207/30	For 30 padlocks - Weight: 0.130 kg

Padlocks

Warning signs

Delineators

Substation signs

Warning signs

Reference	Type	Dimensions	Characteristics
AM-41/1*	aluminium	100 mm side	black on yellow fixing: 3 holes Ø 4.5 mm
AM-41/2	aluminium	200 mm side	black on yellow fixing: 3 holes Ø 4.5 mm
AM-49/1*	aluminium	100 mm side	black on yellow fixing: 3 holes Ø 4.5 mm
AM-49/2	aluminium	200 mm side	black on yellow fixing: 3 holes Ø 4.5 mm
AM-344-GB	aluminium	100 mm side	black letters on yellow fixing: 3 holes Ø 4.5 mm
AM-345-GB	aluminium	100 mm side	black letters on yellow fixing: 3 holes Ø 4.5 mm
AM-344/05	aluminium	50 mm side	
AM-344	aluminium	100 mm side	

*Pack of 10 units.



AM-41/1

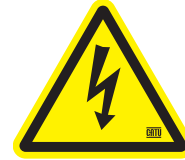

AM-49/1



AM-344/05 - AM-344



AM-344-GB



AM-345-GB

Specialized signs

Reference	Type	Dimensions	Characteristics
AM-20-GB	aluminium	350 x 250 mm	blue letters on plain aluminium
AM-20-RM	aluminium	350 x 500 mm	blue letters on plain aluminium
AM-61-GB	aluminium	150 x 200 mm	
AM-61-RM	aluminium	150 x 200 mm	
AM-215-RM	aluminium	350 x 250 mm	black on yellow SF6 warning
AM-282/2-RM	aluminium	200 x 60 mm	
AM-7002	aluminium	300 x 200 mm	black on yellow
AM-33/3	aluminium	Ø 300 mm	red-black on alu
AM-34/2	aluminium	Ø 200 mm	red-black on alu
AM-32/3	aluminium	Ø 300 mm	
AP-510-GB	plastic	420 x 297 mm	golden rules
AP-951/2	plastic	200 x 200 mm	red on white

Other models, please consult us!



AM-20-GB



AM-20-RM



AM-510-GB



AM-215-RM



AM-282/2-RM



AM-7002



AM-61-GB



AM-61-RM



AP-951/2



AM-33/3



AM-34/2



AM-32/3

Warning sign

Attachment: one hole Ø 10 mm.
Marking for indelible writing: see page ??.



AP-499/1

Reference	Type	Ø (mm)
AP-499/1	plastic	100

Warning flags

Brightly colored ribbon.



AL-53

Reference	Dimensions (mm)	Fixing
AL-53	650 x 350	on handle

Grounding flags

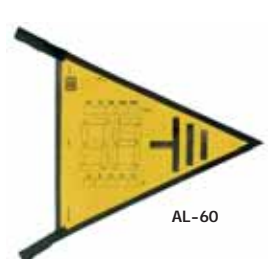

AL-60



AL-58

AL-58	Fixing on handle; for work site
AL-60	Fixing on earthing cable; for immediate identification in open-type switchgears possible inscription: 0 to 99 (by using ALU-SCRIPT markers)

Safety boundary post

For temporary installation.
Used with tough link chain delineators (AL-32/05)
Removal Foot.
Ø 50 mm.
Height: 0.9 m.



AL-316

AL-318

AL-316	Red and white - Weight: 4.2 kg
AL-318	Black and yellow - Weight: 4.2 kg

Chain delineators

Polyamide chains.



AL-31/25



AL-32/05

AL-31/25	Red and white - Length: 25 m
AL-31/05	Red and white - Length: 5 m
AL-32/05	Black and yellow - Length: 5 m
AL-31	Opening ring for AL-31/25

Delineators

Brightly colored ribbon.
Snap hook on one ribbon end and another on spool.
A ring on spool brakes ribbon at desired length.
wide: 50 mm
length: 20 m.



AL-62-A



AL-63-A

AL-62-A	Red ribbon
AL-63-A	Yellow ribbon

63 to 550 kV electronic voltage detectors for indoor and outdoor use

Designed to give users maximum safety, the DETEX detectors of the CC-245 Series are the result of the most modern developments in electronic research. They offer a number of important properties and advantages.

Double signalling

Voltage presence indicated at the same time by:

- 4 extremely bright red flashing electro-luminescent diodes (visible at more than 50 meters even in direct lighting),
- a powerful rated acoustic signal (60 dB/2 m).

Checking

Satisfactory operation of the unit is indicated:

- When pressing the test button, by:
 - the red diodes flashing,
 - the acoustic signal sounding.
- When releasing the TEST button, by:
 - timed green up diodes lighting.

As long as they light, the unit continues its self-testing and the detector is fully operational.

High specifications

- Detectors are adjusted, tested and controlled one by one.
- Remarkably resistant to impacts, vibrations, extreme temperatures, humidity and sudden changes in the atmosphere (condensation, freezing).

- Precise and stable operating threshold. IEC-61243-1
- Insensitivity to induced voltages by limiting the operating voltage range.
- Robust housing made from polycarbonate with high mechanical properties and dielectric strength.
- The contact electrodes are simply screwed to the housing and are therefore easily interchangeable.

Power supply

- One 9 V battery type 6 LR 61.

End fittings:

- "C" for hexagonal sticks.
- "K" for universal sticks.

Weight

650 g (with battery).

Packaging

Units supplied complete with battery and electrode in a rigid synthetic case with handle.

- Recommended sticks: CM-4000 serie. See page 114.

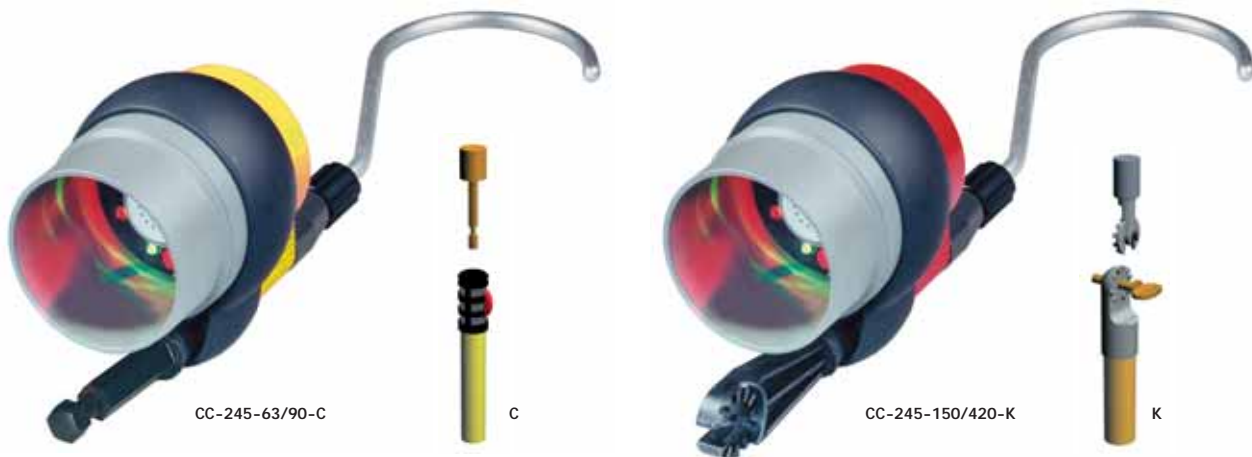

Reference	Operating voltage (Ph/Ph-kV)	Contact electrode Ø mm	Body colour	Freq. (Hz)
FRENCH STANDARD NETWORKS				
CC-245-63/90...*	63-90	120	Yellow	50
CC-245-225/420...*	225-420	200	Red	50
BRITISH STANDARD NETWORKS				
CC-245-66/132-K	66-132	200	Red	50
OTHER MODELS				
CC-245-60/150-K	60-150	120	Red	50
CC-245-63/150-K	63-150	120	Red	50
CC-245-90/225-K	90-225	120	Red	50
CC-245-150/420-K	150-420	200	Red	50
CC-245-225/550-K	225-550	200	Red	50

* Please specify type of mounting when ordering: C or K.

For other voltages, or 60 Hz Frequency detectors (CC-246 Serie) please consult us.

Insulating sticks for voltage detectors and earthing systems

IEC-60855

These 39 mm dia. elements are assembled using a new safety bayonet system connector in aluminium alloy. They allow construction of a large variety of custom made sticks that meet the most varied conditions of application. Calibrated lengths of 1 to 3 meters (with fraction of 0.50 m) permit a huge number of applications.

This range thus allows a stick-length limitation in case of space requirements and carrying capabilities.

For common applications a serie of complete sets including 2 or 3 elements are made to give simple solutions for working distance from 2 to 6 meters.

CM4000

Complete stick with end pieces and hell

Reference	Complete stick length (m)*	Complete stick length (m)**	Insulating length (m)	Weight (kg)
Basic elements				
CM-4610	1.13		0.08	1.35
CM-4615	1.63		0.33	1.80
CM-4620	2.13		0.33	2.80
CM-4625	2.63		0.83	3.30
Intermediate element				
CM-4610-I	1.165		0.8	1.30
CM-4615-I	1.665		1.3	1.70
CM-4620-I	2.165		1.8	2.60
CM-4625-I	2.665		2.3	3.10
Terminal elements				
CM-4610-*	1.115	1.21	0.78	1.00
CM-4615-*	1.615	1.71	1.28	1.40
CM-4620-*	2.115	2.21	1.78	2.20
CM-4625-*	2.615	2.71	2.28	2.70
Fixed length sticks				
CM-4115-*	1.575	1.675	0.82	1.35
CM-4120-*	2.075	2.175	1.07	1.80
CM-4125-*	2.575	2.675	1.32	2.80
CM-4130-*	3.075	3.175	1.82	3.30
Intermediate elements with rain skirts				
CM-4600-J	0.36			0.95

* Add end piece C, K, E.

• With the smallest end fitting.
 •• With the biggest end fitting.



Set of sticks

Complete sets of sticks for standard applications. IEC-60855

Reference	Working distance (m)	Composition
CM-4220*	2	2 elements: CM-4610+CM-4610-*
CM-4230*	3	2 elements: CM-4615+CM-4615-*
CM-4240*	4	2 elements: CM-4620+CM-4620-*
CM-4345*	4.5	3 elements: CM-4615+CM-4615-I+CM-4615-*
CM-4360*	6	3 elements: CM-4620+CM-4620-I+CM-4620-*

* Add end piece C, K, E.

For cables < 95 mm² CM-4000 serie is recommended.

Carrying and storage stick case

Case especially designed for Ø 39 mm new range sticks. Carrying capacity: 3 elements.



CM-3000 480 x 330 x 120 mm - Weight: 1.2 kg

Clamps

Insulating sticks and earth clamps

Fixed points and cables

Accessories

HV and EHV clamps manoeuvrable by insulating stick

Body in aluminium alloy with trapezoidal threaded screw. Interposed elastic washers in the clamping system improve efficiency and insure a higher withstand in case of electrodynamic shock. Manoeuvring by CM-6 insulated stick of appropriate length and characteristics.

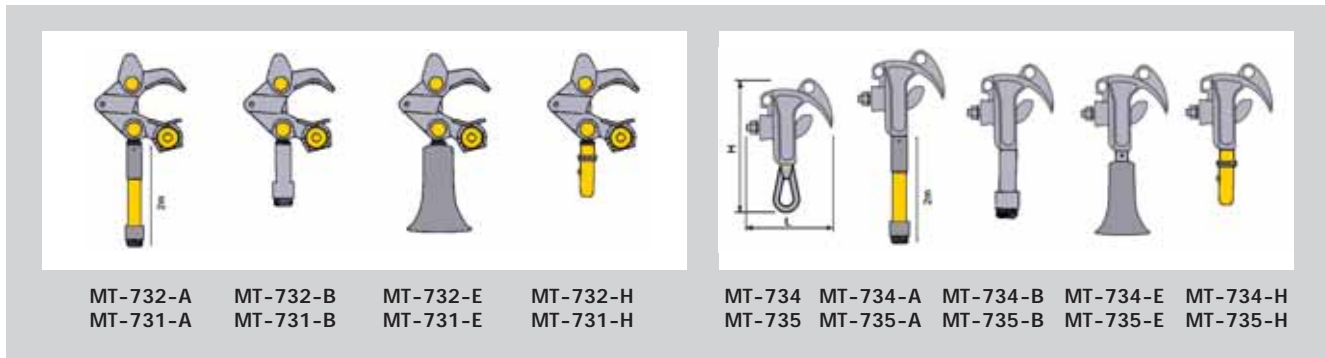

Reference	Clamping capacity (Ø mm)	Test current (kA/1s)	Copper connection			Weight (Kg)	Dimensions (mm) h x L x thickness
			Copper cables (mm ² max.)	Contact range width (mm)	Stud or hole		
MT-731*	5-60	40	150	45	M 12	1.45	200 x 200 x 50
MT-732*	40-120	40	150	45	M 12	1.45	200 x 200 x 50
MT-734*	5-40	40	150	40	M 12	0.8	145 x 125 x 52
MT-735*	15-60	40	150	40	M 12	0.8	195 x 135 x 45
MT-737*	20-120	40	150	40	M 12	1.35	340 x 200 x 55

* Add type of connection A - B - E - H.

Attachment of MT-734/MT-735 clamps with MT-717-3-B hook.

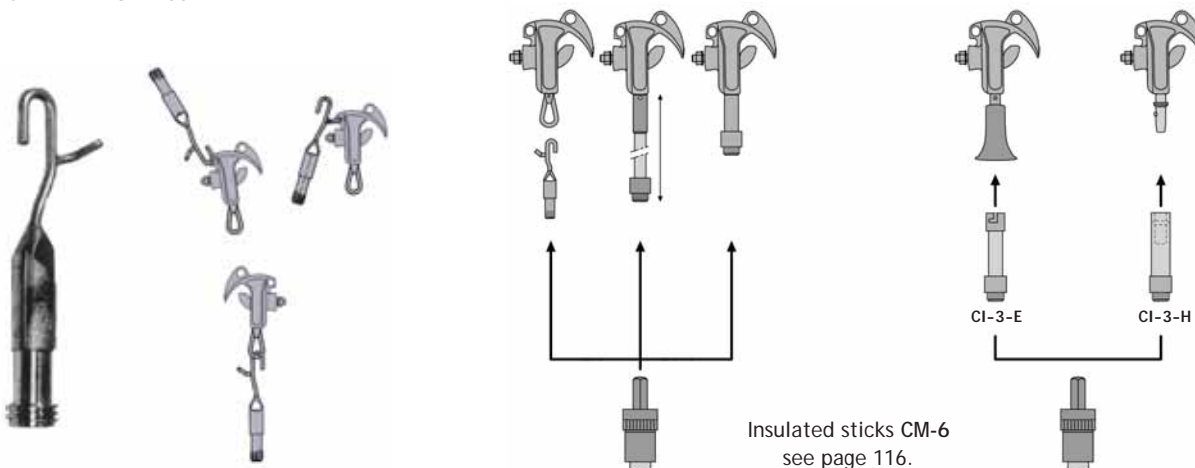

Insulated sticks CM-6 see page 116.

Insulating sticks for short circuiting and earthing systems

- 46 mm dia. single type elements, yellow colour, with superior characteristics, they are connected between them without any prior order of assembly.
- These elements allow "long length" assemblies which can support short-circuit systems with large cross-section cables.
- Shockproof guard and pole end cap.

Reference	Length (mm)	Weight (Kg)
CM-6-15	1.5	2.40
CM-6-20	2.0	3.20
CM-6-25	2.5	4.00
CM-6-30	3.0	4.80



For cables ≥ 95 mm² CM-6 series is recommended.

Earth clamps

Copper aluminium bronze earth clamps.

Reference	Test current	Dimension (mm) Weight (kg)	Connection	Clamping capacity (mm)
MT-843	40 kA/1 s	45 x 106 x 165 0.95	hole: Ø 13 mm	• Ø 6-35 - 0-35
MT-847	30 kA/0.5 s	45 x 106 x 170 1.00	hole: Ø 13 mm	- 0-25
MT-852	40 kA/1 s	70 x 125 x 155 1.40	hole: Ø 13 mm	Fixed points
MT-853	40 kA/1 s	65 x 130 x 135 1.00	hole: Ø 13 mm	Fixed points



Clamps

Insulating sticks
and earth clamps

Fixed points
and cables

Accessories

Adjustable fixed points

For large vertical or oblique heavy duty conductors.

Reference	Rating insulation (kA/1s)	Weight (kg)	Dimensions L x W x T (mm)	Conductors Type	Conductors Ø (mm)	Description
MT-790	30	1.400	255 x 105 x 50	copper	12-60	arm Ø 18 mm
MT-792	30	0.855	270 x 105 x 60	aluminium	12-60	arm Ø 20 mm
MT-797	20	1.200	240 x 170 x 60	aluminium	60-120	arm Ø 20 mm



Copper and aluminium cables

Copper cables

Extra flexible braided multi-strand cables.

A Transparent PVC sheath, with cable section identification.

IEC-61230

B Transparent silicon sheath according to IEC-61230. Resistant to temperature variations (-40 °C to +70 °C) with double IEC triangle marked on cable section.



A	B	Rating (kA/1s)	Cable		Section (mm ²)
			Weight (kg/m)	Ø (mm)	
M-24-70	M-24-70-S	16	0.768	12	70
M-24-75		20	0.800	12	75
M-24-95	M-24-95-S	20	1.000	14	95
M-24-120	M-24-120-S	30	1.280	17	120
M-24-150	M-24-150-S	36	1.630	19	150

Aluminium cables

Extra flexible braided multi-strand cables.

Transparent PVC sheath, with cable section identification.



Reference	Rating (kA/1s)	Cable		Section (mm ²)
		Weight (kg/m)	Ø (mm)	
M-28-70	10.0	0.240	13.4	70
M-28-120	17.5	0.430	19.00	120
M-28-150	20.0	0.510	21.00	150

Jumper cables realisation specially manufactured items



Quotations in accordance with faisability.
For all details:
Tel.: 33 142314624 / www.catuelec.com

Earthing kit support

Welded steel assembly with galvanization surface treatment.
Writing zone available.



MT-895 230 x 230 x 150 mm - Weight: 0.9 kg

Rope operated clamp

Description
V-shaped aluminium body.
Spring operated swinging jaw with pre-set.

Operation
Attachment and removal is carried out from the ground or from the cross-arm, using a rope passed previously over the conductor to be earthed.
- Attachment: the clamp is pulled up by the rope. Pulling on the rope triggers the spring and closes the jaw.
- Removal: pulling on the rope attached to the hinged saddles causes the clamp to pivot and free the jaw.

For conductors reached from the ground:
- up to 10 m: by using MT-709-B reel launcher placed on a CM-6 SERIE Stick (see page 96) that passes the rope over the conductor;
- up to 20 m: by using a MF-60 wire projector. This projector fires an arrow carrying a braided nylon wire which sets the rope. The clamp is then fixed to the rope and attached onto the conductor.
• Earthing cable with ranger (mm²): 2 x 120.
• Cable connection crimped log hole: M 12.



Reference	Clamping capacity (Ø mm)	Rating insulation (kA/1s)	I asymmetrical (A)	Dimensions (mm) h x L x thickness	Weight (Kg)
MT-701/1	12-48	30	72	195 x 120 x 175	2.00

Cable-launcher projector

Used to fire the insulating rope for setting the MT-701/1 clamp, this wire-projector may also be used for checking the absence of voltage from the ground by throwing a very light fuse wire over the conductor (in case of voltage, arcing will occur to warn the operator).

- MF-60 Wire-projector
- MF-61 Spare arrow
- MF-62 Spool of 30 m of fuse wire
- MF-63 Spool of 100 m of fuse wire
- MF-66 Spool of 30 m of nylon lead



Reel launcher and insulated rope reel

This device contains a shaft on which the rope reel is engaged, and a spring system which triggers the ejection of the reel when it comes in contact with the conductor. To be fixed on a MAJOR SERIE Stick, depending on the height of the conductor to be reached.



- MT-709-B Aluminium alloy launcher - Weight: 0.310 kg
- MT-708/40 Special quality nylon on shock proof reels; equipped with 2 snaps. Rope Ø 6 mm - Length: 40 mm

Short-circuiting and earthing systems carrying bags

Strong water proof canvas. Reinforced bottom.

- M-87-53 380 x 250 - Height: 400 mm - Weight: 2 kg
- M-87-153 380 x 250 - Height: 600 mm - Weight: 2.5 kg
- M-87-295 550 x 300 x 300 mm - Weight: 2 kg



High voltage



DISTRIBUTED BY:



Group Sicame

www.catuelec.com

10/20 Avenue JEAN-JAURES • B.P.2 • 92222 BAGNEUX CEDEX (FRANCE)

Phone: + 33 1 42 31 46 00 • Fax: + 33 1 42 31 46 34