

Table of Contents



XIT6000-CA

3/8" Tie-Lok® Tool

Table of Contents	Page
Warranty & Safety Guidelines	3
Parts Identification	4-6
Air Supply Requirements	7-8
Tool Overview	8
Setup and Assembly Instructions	9-12
Remote Operations Fixturing Tips	13-14
Operating Instructions	15
Operating Tips	16
Troubleshooting	17-21
Preventative Maintenance	22-29
Tension Cylinder Pressure Monitoring System	30-36
Tool Calibration Procedure	37-38

Warranty & Safety Guidelines



XIT6000-CA
3/8" Tie-Lok® Tool

Warranty:

For Warranty information visit the following URL

www.BAND-IT-IDEX.com/Warranty.html

Safety Guidelines

- Read this manual and become familiar with the tool before installing any clamps.
- Protective eyewear should be worn when connecting and disconnecting the tool to compressed air sources and during operation.
- Wear appropriate gloves for handling steel while operating this tool, applying stainless steel clamps and removing scrap clamp tail.
- Clamp tensioning can be immediately stopped by releasing the tool trigger system.
- When applying clamps, care should be taken to insure fingers and loose clothing are not in the way of the clamp being applied.
- Never attempt to clamp objects which have a potential to burst, shatter or otherwise cause bodily harm.
- Disconnect air supply and electrical power prior to maintenance and disassembly of tool components.
- Liquids or lubricants should never be put into the air lines.

Parts Identification



XIT6000-CA 3/8" Tie-Lok® Tool

Production tools will experience wear of specific parts. Preventative maintenance, including regular cleaning and lubrication, will reduce the replacement frequency of these parts. To maximize life, use synthetic gel lubricant containing Teflon. See (pages 22-29) for tool maintenance. When repairing tools, threaded fasteners should be secured using a small amount of Loctite, Red – High strength.

Part #	Replacement Parts Description	Quantity per Tool
I19691	Knife Assembly	1
I13887	Knife Pin	1
I17687	Knife Pin Access Screw	2
I19787	Blade	1
I20487	Blade Pin	1
I20387	Tension Pin	1
I18487	Tension Gripper	1
A38487	Gripper Spring	2
I19187	Tension Block	1
I16387	Lubricant (synthetic gel lubricant containing Teflon)	

Note- Parts and part numbers are subject to change. Please have tool model and serial #'s available when calling the factory for service assistance.

Parts Identification



XIT6000-CA 3/8" Tie-Lok® Tool

XIT6000-CA Tool Body

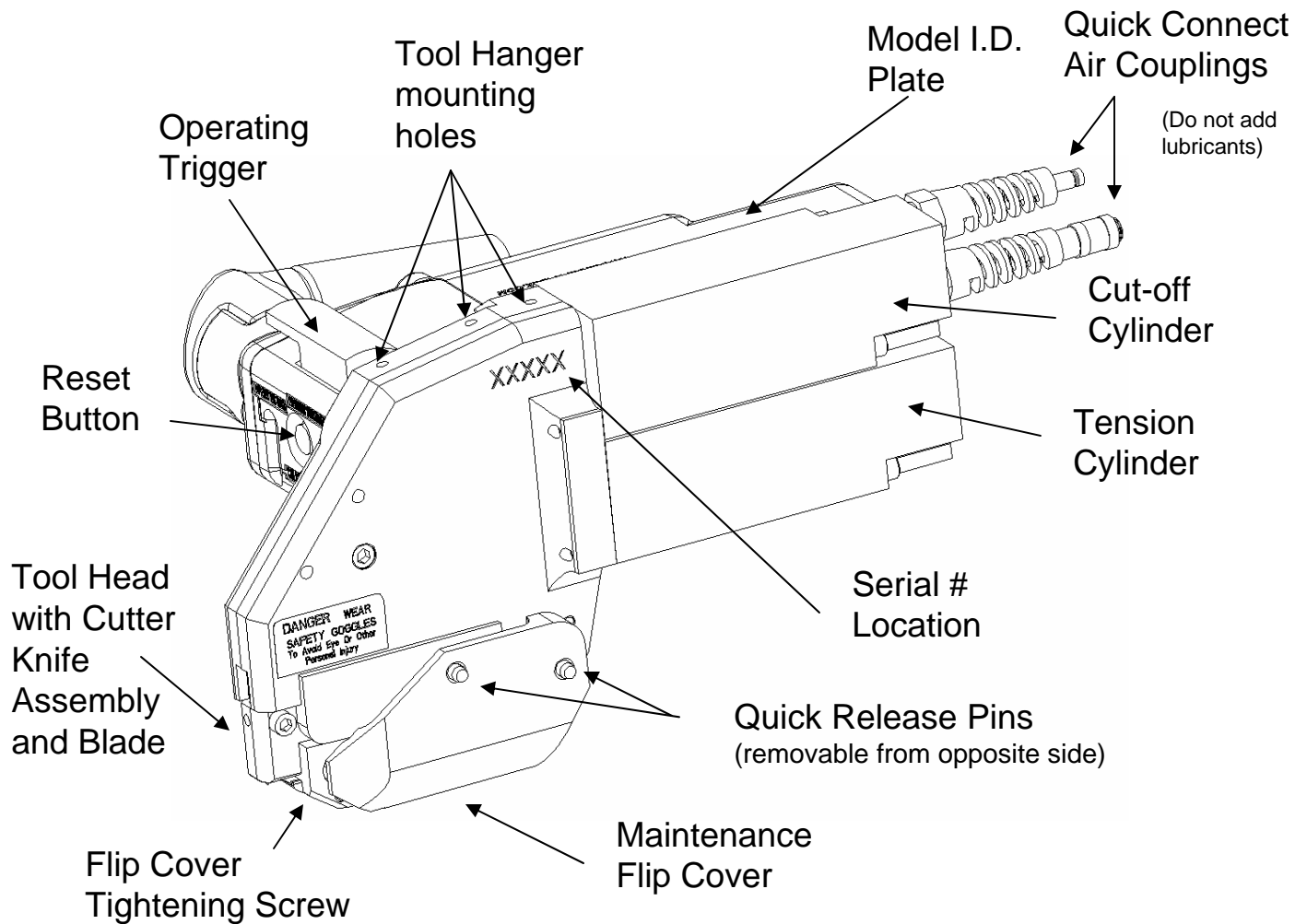

Important: Before disassembling tool, be sure to shut-off air supply on the Air Controller Module. Unplug the data cable going to the tool.

Parts Identification



XIT6000-CA

3/8" Tie-Lok® Tool

Air Controller Module

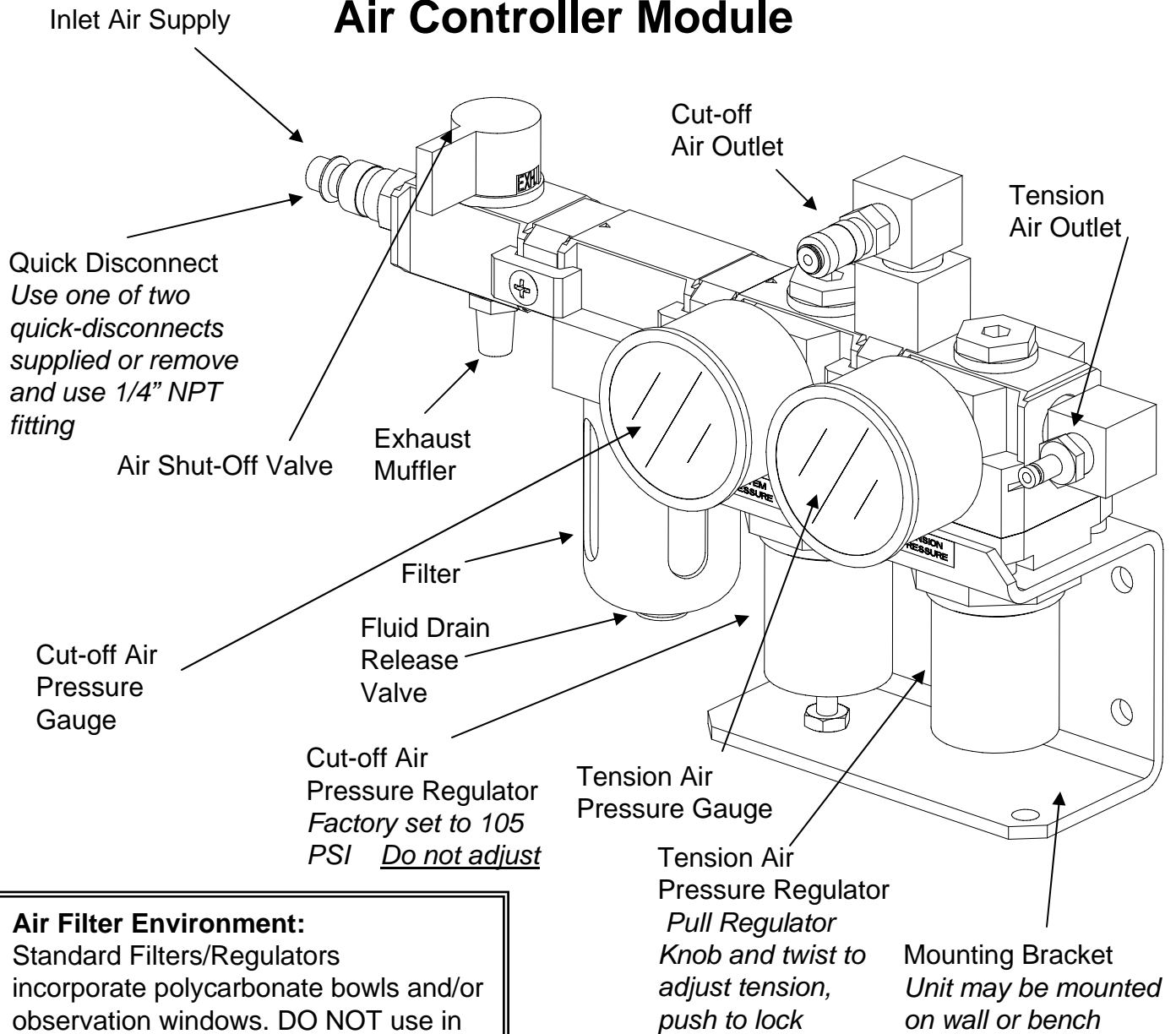

Air Filter Environment:
Standard Filters/Regulators incorporate polycarbonate bowls and/or observation windows. DO NOT use in an environment that will expose the above mentioned components to synthetic fluids, organic solvents, chemicals, cutting lubricants, thread lock solutions or similar materials.

Note: Air Controller Module must be mounted and operated in a horizontal position.

Air System Requirements



XIT6000-CA 3/8" Tie-Lok® Tool

The XIT6000-CA is a pneumatic tool that needs a clean and dry supply of air to operate. For proper tool performance, the air requirements at the inlet to the BAND-IT Air Controller Module of the XIT6000-CA must be:

Item	Min	Max
Inlet Supply Pressure (PSI)	100	140
Inlet Supply Air Flow (SCFM)	1.5	
Particle Size In Air Supply (microns)		5
Air Moisture Content		20% RH
Tension Pressure Settings (PSI)	60	75
Cut-off Pressure Setting (PSI)	100	110

*The BAND-IT Air Controller Module includes a filter to meet these requirements.

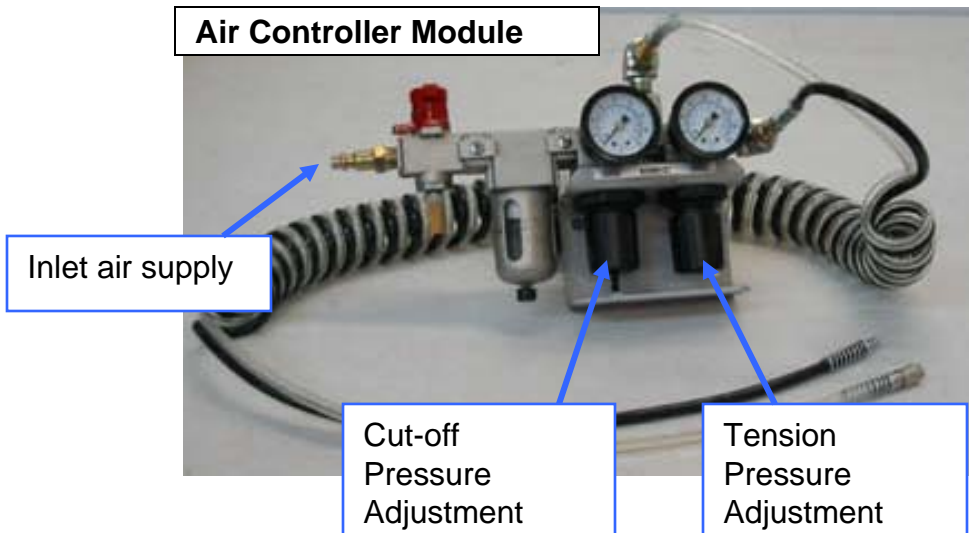



Pneumatic System:

The pneumatic valves and cylinders all have seals or o-rings that wear out. Once the o-rings in the cylinders begin to wear, air is allowed to pass by the pistons in the cylinders, which can affect the performance of the tool and cause the calibration of the tool to drift. The cylinders are permanently lubricated, but premature wear can be caused by debris in the air lines or the presence of water and oil, which can break down the lubrication. The 4-way valves in the tool can be affected by debris and oil in the air lines that cause the valve to stick and not operate as is necessary. Over time, the mechanical linkages in the tool will also begin to wear. This wear will cause some drift in the calibration of the tool, but does not have the same effect of wear in the air system.

To address the potential problems associated with the air supply, BAND-IT recommends the use of an Air Booster System. In addition to filtering and drying the air, it will also maintain a steady pressure of 100 -110 PSI assisting the proper function of the tool.

Tool Function:

The XIT6000-CA tool functions by using an incoming supply of air to actuate a mechanical linkage. The linkage connects to a gripping system that outputs a force on the band portion of the Tie-Lok ties. The output of the tool varies depending upon the air pressure supplied to the tool. If the pressure is increased, the output force increases.

During the tension cycle the tool will continue to pull up or tension the band until the appropriate tension is reached. The tool stops tensioning when the pressure in the tension cylinder equals the inlet tension pressure coming from the air controller module. After the tool has pulled tensioned the tie, the tool switches over to the cutoff cycle. At this point in the cycle the gripping system maintains the force on the tie and a knife is actuated down which forms a dimple and cuts the band.

Equipped with the tool, there is a tension cylinder pressure monitor (Red/Green Light Data Acquisition) that measures the air pressure in the tension cylinder when the tool switches over to cut-off. The pressure is captured from the tension cylinder immediately before cutoff, while the tension force is being held in the band. The electronics of the tool takes this pressure reading and calculates a number for the output force based upon an equation. This equation is derived from a capability study of a normal XIT6000-CA tool fitted with a M28090 calibration device (see Tool Calibration, **page 37**) at the initial build of the tool.

Setup & Assembly Instructions



XIT6000-CA 3/8" Tie-Lok® Tool

The XIT6000-CA shipping container includes: Air Controller Module, XIT6000-CA tool body, coiled air line, owner's manual, tool kit and Tension Cylinder Pressure Monitoring Device kit.

Initial Setup - Pneumatics

- Connect the tool body to the Air Controller Module using the included Coiled Hose Assembly. The hose assembly includes both a clear and black hose. Each hose end includes a female and male fitting, arranged to prevent reversing of connections.
- Connect Air Controller Module to air source (assure air supply meets requirements on **page 7**) and turn RED Shut-off Valve counter clockwise to pressurize tool (supply position).
- Make sure *Cut-off Air Pressure Gauge* located on the left side of the module reads a pressure of 100 PSI min/ 110 PSI max.
- The *Tension Air Pressure Gauge* monitors the tension applied to the clamp tail. Air pressure at the Tension Gauge should be 60-75 PSI for BAND-IT 3/8" Tie-Lok® Ties.

Initial Setup – Electronics

Refer to **pages 30- 36** of this manual for setup and operating instructions for the Tension Cylinder Pressure Monitoring System.

Setting the Tool Air Pressure

The air pressure supplied to the XIT6000-CA tool should be adjusted so that the output force of the tool falls between 333-368 lbs. To correctly set the air pressure from the air controller module going to the tool, attach the calibration device (**page 37**) and hook up the air supply. Activate the tool by depressing the trigger. When the tool stops moving, read the display on the calibration device. If the force on the readout is not within the Ford Engineering Specification of 333-368 lbs, adjust the tension air pressure between 60-85 psi and repeat this test until the force is within range. Press the tool reset button to release the force and remove the calibration device. If the tool cannot be adjusted into this range by varying the pressure between 60-75 psi, then the tool is either out of calibration or is not working properly and should be returned to BAND-IT.

Setup & Assembly Instructions



XIT6000-CA
3/8" Tie-Lok® Tool

Handle adjustment:

- Using 1/4" hex key (supplied), adjust the Support Arm/Handle to ergonomically match the operators hand.
- Be sure not to adjust the Handle too far outward (beyond interlocking legs) or the handle will not function properly or provide support to the operator.



Hanger Support Instructions:

1. A steel hanger can be utilized for supporting the tool with a counterbalance. Full weight of tool should not be supported by a single hole.
2. A hanger can be installed (as shown) into one of the three supplied threaded holes. To prevent internal damage, only 1/8" of the hanger threads should be threaded into the hole.
3. Secure the hanger against the tool body with a lock nut as shown. This will prevent movement of the hanger during tool operation.
4. Use a light application of Loctite, Red, high-strength, on threads of hanger prior to installation.

Hanger Mount

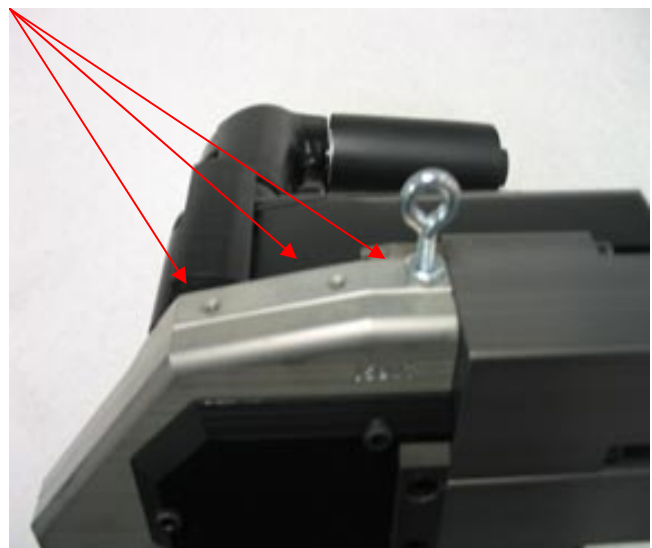

Setup & Assembly Instructions



XIT6000-CA 3/8" Tie-Lok® Tool

Fixture Locating Points

Three additional fixture mounting holes are available to assist with mounting the XIT6000-CA. Thread size is #10-32 for each of the holes. Usable thread depth is .400" for two of the three fixture holes. One hole is utilized to attach and lock the tool body halves together. This hole may also be used for fixturing, provided the #10-32 cap screw is replaced with a similar threaded screw with appropriate thread length secure the two halves together in addition to fixturing.

Fixture Mounting Locations

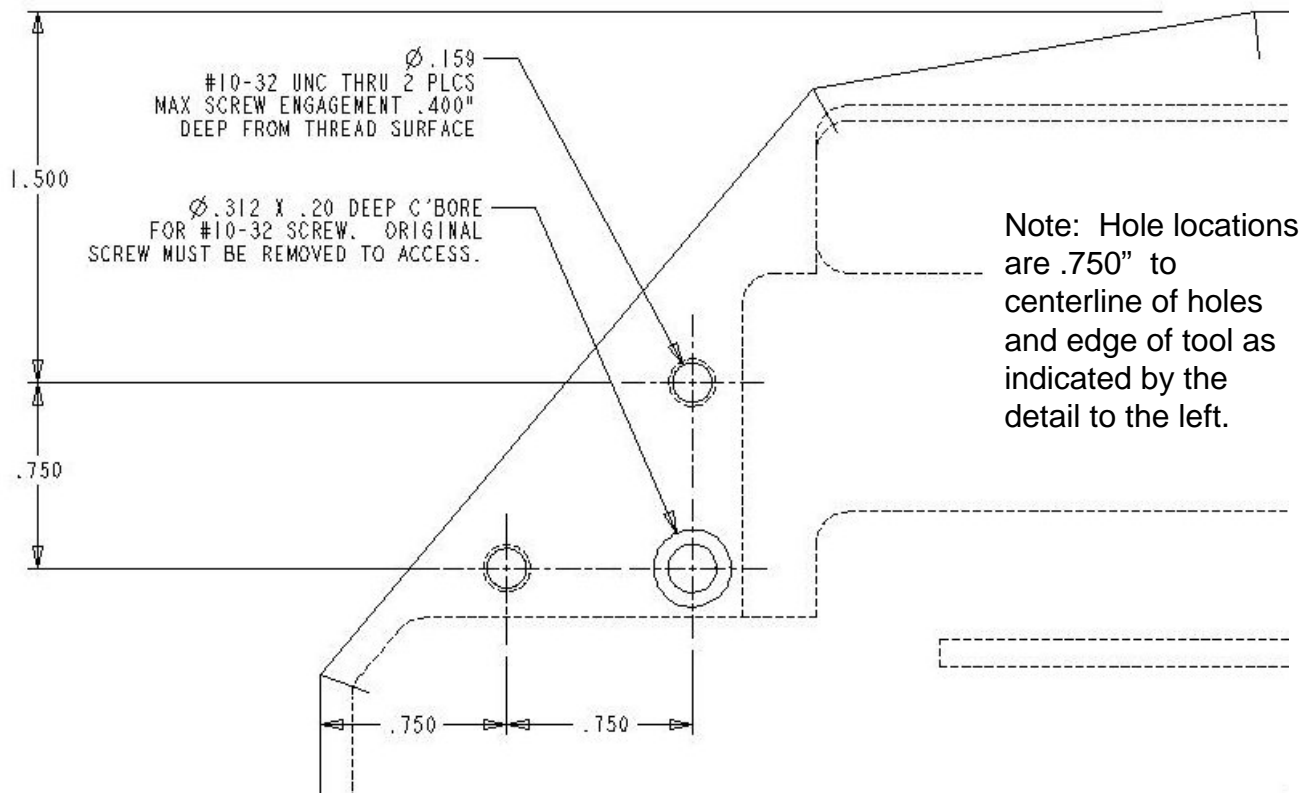
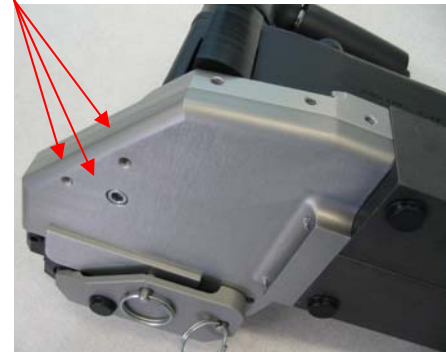

Setup & Assembly Instructions



XIT6000-CA 3/8" Tie-Lok® Tool

Part of insuring that the tool is producing a strong lock is making sure that it approaches the application correctly and is fixtured to allow repeatability of application. The tool should approach the surface of the wheel tangent to the point on the wheel where the buckle of the band is to be applied. The tool should be allowed to float 1/8" – 1/4" above the surface of the wheel to allow the buckle to move to the proper position for cut-off. Once the tool begins tensioning, the band will pull the tool down to the surface of the wheel.

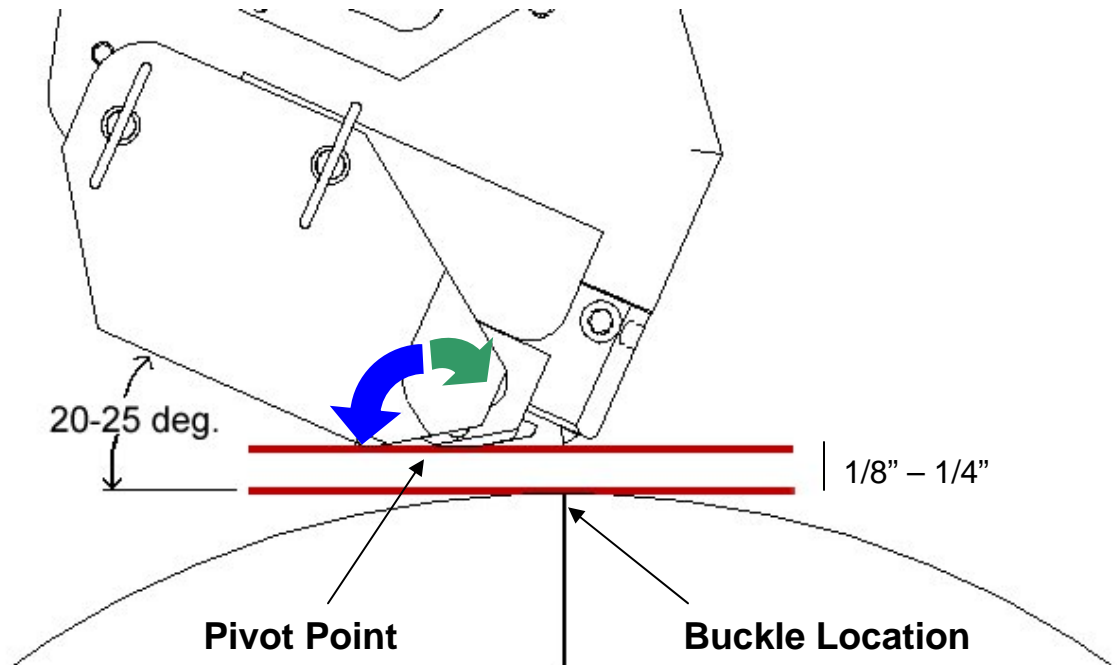

As the band is tensioning, the tool may rotate clockwise up to 5 degrees about the pivot point (Green Arrow). During the cut-off cycle, the tool must be allowed to rotate counter-clockwise up to 35 degrees (Blue Arrow). Because of this movement, **BAND-IT recommends that the tool be mounted in a fixture that will provide adequate rotation during both cycles.**

XIT6000 Orientation Requirements:

- The XIT6000-CA-XX tool has a number of Tool/Clamp/Object Being Clamped orientation requirements that must be followed in order to reach an acceptable end result.
- In concept, the fixture maker should attempt to replicate the natural human wrist/elbow/shoulder motions that would occur when operating the tool in the hand-held configuration, allowing the tool to float along a plane through the entire Tension (pull-up) and Cut-Off (lock) process.
- **The tool MUST:**
 - Be permitted to adjust spatially to permit the clamp being applied to achieve optimal attachment force(s).
 - Contact the object being clamped at the tool's natural optimal point without restricting or forcing.
- **Suggestions Include:**
 - The tool fixture should be able to accommodate some longitudinal rotational movement, i.e. "wrist like", at the final moment of applied tension. The purpose being, to allow the tool freedom of movement to orient itself in its best natural orientation as relates to the clamp and the object-being-clamped.
 - A home or neutral position should be established at the optimal final position with +/- 10-12½ degrees of rotational freedom being allowed from the pivot point.
 - The tool fixture should be able to accommodate some extensive movement, i.e. "elbow like", during the tension phase to allow the tool to be "pulled" up to the object being clamped.
 - Deviations from accommodating the natural inclination of the tool/clamp/object being clamped, may negatively impact the integrity of the final assembly. The clamp should fully rest upon the object being clamped at the time of final tension and cut-off. If the tool can not reach the object being clamped and attempts to cut-off, the clamp and/or lock may not form optimally.
 - Attention MUST be paid to the plane angle of the applied clamp at the prescribed position per FORD ES 6L2A 1A176 A_.

Remote Operation & Fixturing Tips Supplement



XIT6000-CA

3/8" Tie-Lok® Tool

XIT6000 Configured for Remote Actuation:

- The XIT6000-CA - 11 has trigger option 1 and is a modified version of the base unit XIT6000-CA - 01. The XIT6000-CA-01 is manually operated via the incorporated thumb actuation lever. The XIT6000-CA-11 is configured to allow remote operation via palm button or other device permitting the tool to be incorporated into the customer's fixture or assembly process.
- The modification consists of deactivating the thumb lever actuation switch and installing a twin-coiled 10-ft X 1/8" O.D. hose to accomplish the same task via the use of a remote actuation device such as a palm button or other device that can provide a pneumatic signal to pilot the tension control valve.
- Various actuation devices can be incorporated based upon end user requirements. Basic schematic for 2-way & 3-way valves included below. The valve should be set up in the normally closed mode and upon opening the circuit a supply of air is provided.
- The customer is responsible for incorporating this tool into their process, BAND-IT is available to provide advice and recommendations.

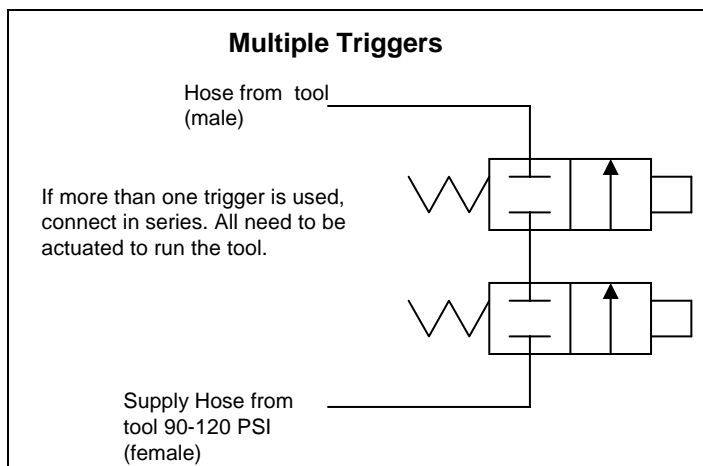
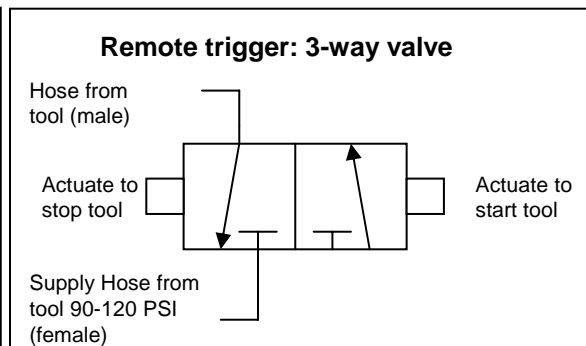
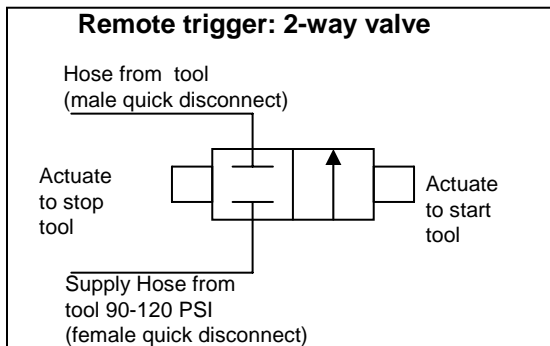

Connect the 2 hoses extending from the tool to the ports of the valve. As the hoses are not marked, they may need to have their connection on the valve reversed if the remote trigger does not start the tool.

Tie Installation:

When installing a tie, a random visual check to verify the presence of a dimple after the tie has been applied is recommended. The dimple is the locking element of an installed band. The XIT6000-CA forms a dimple into the band with the punch. By controlling and monitoring the items that are needed to form a good lock, an operator can help insure that the band will be applied correctly without having to inspect every assembly.

These items are:

- Adequate air pressure and volume (see **page 6,7**)
- Setting the tool air pressure (see **page 7,9**)
- Following recommended PM Schedule (see **page 24**)
- Checking the Tool Punch Height (see **page 25**)
- Proper tool calibration (see **page 37**)
- Fixture mounting the tool properly (see **page 11-14**)

For best performance and to extend tool life:

- Follow preventative maintenance and parts replacement instructions (**page 24**) at appropriate service intervals.
- Do not remove factory applied lubrication from inside tool or use degreaser.
- Do not spray any lubricant or cleaner into the Quick Connect Air Couplings.
- Use nominal recommended tension setting (listed on **page 7-9**). Higher pressure may not result in a tighter clamp, but increases the likelihood of clamp tail jamming and premature worn parts.
- Do not over-tighten Knife Pin Access. Over tensioning of these screws may result in stripping screw threads.
- For maintenance beyond what is described in this manual, consult BAND-IT.

Operating Instructions



XIT6000-CA 3/8" Tie-Lok® Tool

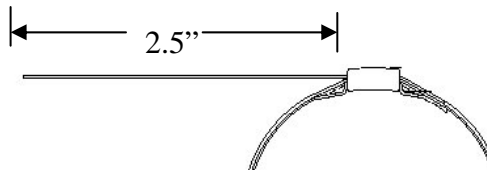

1. Insert clamp tail into tool as shown. Clamp tail length extending into tool must be at least 2.5" (6.4 cm) long. The head of the tool should rest against the buckle. **Note - Do not activate tool while inserting clamp tail. This can cause clamp tail to jam in the Tension Block Assembly.**



2a. Begin tensioning clamp by pushing and holding down operating trigger

b. Band should be applied to a uniform solid surface allowing the buckle adequate support during the clamp locking and clamp tail cut-off operation.



3. While tensioning clamp, hold tool slightly tipped forward. This will assist proper clamp installation. Continue to hold down operating trigger until tool completely tensions and cuts off clamp. Release trigger after cut off.



4. After clamp is completed, clamp tail scrap must be removed from tool. Clamp tail scrap is not ejected automatically. Tool is now ready for next clamp.

Tool Fails to Fully Tension Clamp:

Failure to fully tension the clamp can be caused by a variety of factors. The two most common factors are: incorrect tension pressure and problems in the Tension Block Assembly.

- Check tension pressure setting on Tension Pressure Gauge of Air Controller Module. Adjust pressure per the settings in the **Setup & Assembly Instructions** section found on (pages 9-12).
- After air pressure settings are verified or corrected, if failure to fully tension clamps continues, evaluate the clamp tail dimple pattern. If elongated dimples are present, the problem may be with the Tension Block.

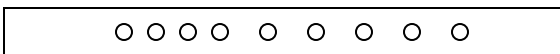

*Normal clamp tail
dimple pattern.*

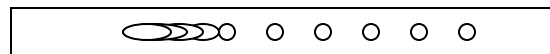

*Clamp tail dimple pattern indicates
problem in the tension block
assembly.*

- If a problem is indicated, follow the instructions on **page 23** to remove the tension block assembly.
- Examine the Tension Block components for excess lubrication. Refer to lubrication instructions on **pages 23, 26 - 28**.
- If dirt or debris is visible, follow the cleaning instruction on **page 23**.
- Examine the Tension Block and Gripper for wear (see below).
- If wear is indicated, follow the instructions on **page 23** to replace the worn parts.

Tool fails to cut off clamp tail:

- The Inlet Air Pressure may be low. Check air supply to Air Controller Module. Cut-off Pressure Gauge should indicate 100 PSI minimum, 110 PSI maximum. See **pages 7-8** for air supply requirements.
- The scrap clamp tail from the previous clamp may not have been removed. Press the Reset Button to release the tension on the clamp and remove the scrap clamp tail.
- The Cutter Blade or Knife may be worn. See below for Cutter Blade inspection and replacement.

• **Note:** The Flip Cover Tightening Screw is factory tensioned to a torque value of 12 -15 inch pounds and will need to be retensioned after the quick release pins are reinstalled upon completion of maintenance. Over tightening of screw can result in the quick release pins to bend. This would then make them hard to remove or insert.

Cutter Blade inspection and replacement:



1. Loosen the Flip Cover Tightening Screw (**see note above**) to remove both Quick Release Pins as shown.

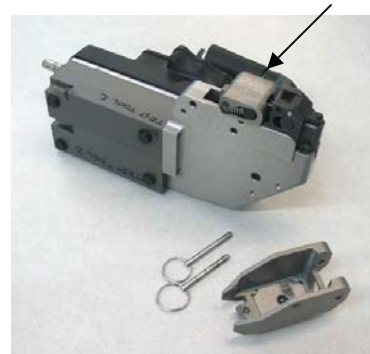

2. Remove Flip Cover and Tension Block Assembly for cleaning and lubrication.



3. Remove the Cutter Blade Pin and Cutter Blade. The Cutter Blade has two working edges and can be rotated 180° to use the second edge prior to replacement.

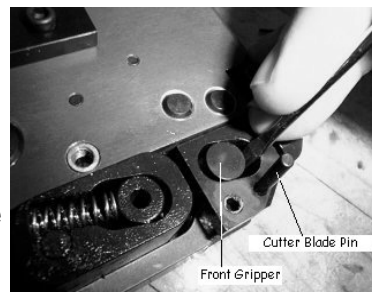

4. When installing the Cutter Blade Pin, use a small screwdriver to push the front gripper toward the back of the tool.

Trouble Shooting Matrix



XIT6000-CA

3/8" Tie-Lok® Tool

Symptom	Probable cause	Recommended Fix	Page
Tool will not tension properly (i.e. slipping, slow etc.)	Rear tension block slipping, therefore tool does not reach cut off tension.	Remove and inspect gripper block assembly. Replace as required.	23
	Front gripper slipping	Remove and inspect front gripper and gripper guide arm. Replace if worn.	*
	Dirty front and rear gripper interfaces	Remove and clean contact surfaces.	23
	Air leaks when trigger is not activated	Listen for air leaks. Check red valve , Air lines, and replace as required. No air leaks allowed. Remove and replace as required or contact BAND-IT.	29
	Worn flip cover and tool body	Inspect inside of flip cover and bottom of tool body for excessive wear. Replace flip cover as required. For tool body wear contact BAND-IT for evaluation.	28
	Water or oil in pneumatic lines.	Purge pneumatic lines and red four way valve assembly. Install a desiccant air dryer or similar which meets tool set up requirements (see manual).	*
	Tool cutting before full tension applied.	Verify timing. If required, remove right side body and adjust timing valve. Replace if damaged.	29
Tool will not cut off clamp tail	Premature release of trigger	Hold trigger down until tool completes cut off cycle	15
	Fluctuating facility air pressure	Verify facility air pressure meets tool set up requirements (see manual). Air booster system might be required.	7,8
	Worn knife/blade	Remove and replace knife and blade. Refer to maintenance schedule.	22
	Timing valve adjustment	Verify timing. If required, remove right side body and adjust timing valve. Replace if damaged.	29
	Rear tension block slipping, therefore tool does not reach cut off tension.	Remove and inspect gripper block assembly. Replace as required.	23
	Coiled hose line has air leak	Verify no air leaks in coiled hose assembly. Remove and replace as required.	7,8
	Front gripper slipping	Remove and inspect front gripper and gripper guide arm. Replace if worn.	*
	Red four way valve malfunction	Remove clean and inspect. Replace as required.	*
	Worn blade pin or housing	Remove and replace blade pin and/or housing.	18

Trouble Shooting Matrix



XIT6000-CA

3/8" Tie-Lok® Tool

Symptom	Probable cause	Recommended Fix	Page
Tool will not cut off clamp tail - Continued.	Linkage components damaged, causing interference	Remove tool left side body and verify linkage mechanism. Remove and replace damage as required or contact BAND-IT.	26,27,28
	Cut-off cylinder seal damaged or leaking	Remove left side tool body and verify seal integrity	*
	Cut off pneumatic air leak	Verify Coiled Hose Assembly is free of air leaks. Remove handle cover and inspect for leaks on gray anodized valve assembly and red valve assembly. Inspect for leaks in pneumatic system.	*
	Water or oil in pneumatic lines.	Purge pneumatic lines and red four way valve assembly. Install a desiccant air dryer or similar equipment which meets tool requirements (see manual).	7
	Screws holding Cutter Knife Pin too long or loose	Verify proper length screws and Cutter Knife Pin seated properly.	22
	Coiled hose line is reversed (i.e. cut off pressure is actually going to tension cylinder.	Verify coiled hose air line from right side of control module enters bottom fitting on tool.	6,7
Loose clamp after cut-off	Improper tool use	Verify operator properly trained and familiar with tool manual.	8,15,16
	Tension setting too low	Adjust Air Controller Module's tension setting per instructions.	7
	Improper buckle location or application	Locate buckle on smallest radius area. Buckle must be supported underneath during application. Contact BAND-IT for application verification / recommendation.	12,14,16
	Tool cuts clamp tail before reaching full tension.	Verify timing. If required remove right side handle and adjust Timing Valve. Replace if damaged.	29
	Worn Cutter Knife/ Cutter Blade	Remove and replace Cutter Knife and Cutter Blade. Refer to maintenance schedule.	18
	Air leaks when trigger is not activated	Listen for air leaks. Check red valve, Air lines, and replace as required. No air leaks allowed. Remove and replace as required or contact BAND-IT.	Contact BAND-IT for assistance
Tool will not operate when trigger is depressed	Control Module air pressure valve is in "off" position.	Rotate Control Module valve to open position. Verify gauges read air pressure.	6
	Pinched coil hose line	Loosen fitting on coiled hose assembly where it enters tool body.	7
	Kinked or pinched air line	Remove right side handle and inspect air lines. Remove and replace as required.	29
	Tension piston interference with hanger screw holes.	Loosen Hanger Screw on top of tool. Thread engagement cannot exceed .125 in.	10
	Quick disconnect fittings not positively engaged.	Disconnect and firmly reconnect.	6,7

Trouble Shooting Matrix



XIT6000-CA

3/8" Tie-Lok® Tool

Symptom	Probable cause	Recommended Fix	Page
Tool will not operate when trigger is depressed	Control Module air pressure valve is in "off" position.	Rotate Control Module valve to open position. Verify gauges read air pressure.	6
	Pinched coil hose line	Loosen fitting on coiled hose assembly where it enters tool body.	5
	Kinked or pinched air line	Remove right side handle and inspect air lines. Remove and replace as required.	29
	Tension piston interference with hanger screw holes.	Loosen Hanger Screw on top of tool. Thread engagement cannot exceed .125 in.	10
Clamp will not insert into tool	Control Module air pressure valve is in "off" position.	Rotate Control Module valve to open position. Verify gauges read air pressure.	6
	Clamp tail inside tool	Remove clamp tail, if jammed remove maintenance/flip cover and remove clamp material.	15,18
	Knife is in forward position.	Remove or replace knife. Verify missing and or damaged linkage.	22,26
	Wrong clamp type for	Verify proper tool for selected clamp.	9
Handle will not adjust	Handle nut is damaged/misaligned.	Remove handle assembly and inspect nut/housing for damage. Replace as required.	10

* = for additional assistance, contact BAND-IT



The XIT6000-CA requires preventative maintenance as indicated below. The “Clamps Installed” column indicates how many clamps can be installed between each servicing.

Tool Preventative Maintenance:

The tool has some wear components that must be checked and replaced on a certain schedule. BAND-IT has developed a Preventative Maintenance (PM) schedule to help facilitate these requirements. An excerpt from this PM Schedule is shown below. If tools are experiencing difficulties during function or there audible air leaks coming from inside the handle, the tool should be returned to BAND-IT-IDEX, Inc. for servicing.

Preventative Maintenance Schedule

Clamps Installed	Maintenance Item	Maintenance Action
12,500	Tension Block Assembly	Clean & Re-Lubricate
12,500	Flip Cover	Clean & Re-Lubricate
25,000	Mechanical Linkage	Clean & Re-Lubricate
25,000	Tool Head	Clean & Re-Lubricate
25,000	Cut-off Blade	Rotate (page 18)
25,000	Cut-off Knife Assembly	Replace
25,000	Front Gripper	Clean, re-lubricate, and inspect for multiple broken teeth
50,000	Cut Off Blade	Replace
50,000	Tension Block Assembly	Replace Assembly
50,000	Front Gripper	Replace gripper

Knife Assembly Replacement:



A) Remove Cutter Blade as described on **page 18**.

B) Remove the Knife Pin Access Screws. These are special length screws.

Important: When repairing tools, threaded fasteners should be secured using Loctite, Red - high strength.

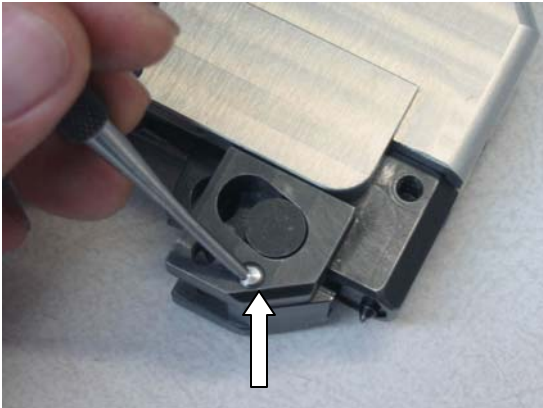

To remove Cutter Knife Pin the Knife Assembly must be in its uppermost position indicated by the Cutter Knife Pin in line with the access hole. If not aligned, connect the tool to the Air Controller Module. Open the Air Shut-off Valve to momentarily pressurize the tool. Close the valve and disconnect the tool from the Air Controller Module. Then push out the Cutter Knife Pin with a piece of wire (for example, a bent paper clip).



Once the pin is removed, grasp the Knife Assembly with a pair of needle-nose pliers and pull out of tool head. Examine for wear and replace if needed.

Re-install all parts in reverse order. After the Maintenance Flip Cover is installed and Quick Release Pins are in place, apply tension to the Maintenance Flip Cover Tightening Screw, torque to 12-15 inch pounds.

Tension Block Assembly Maintenance:

Remove the Maintenance Flip Cover by loosening the Maintenance Cover Tightening Screw on the Maintenance Flip Cover and removing both Quick Release Pins as shown on **page 18**.

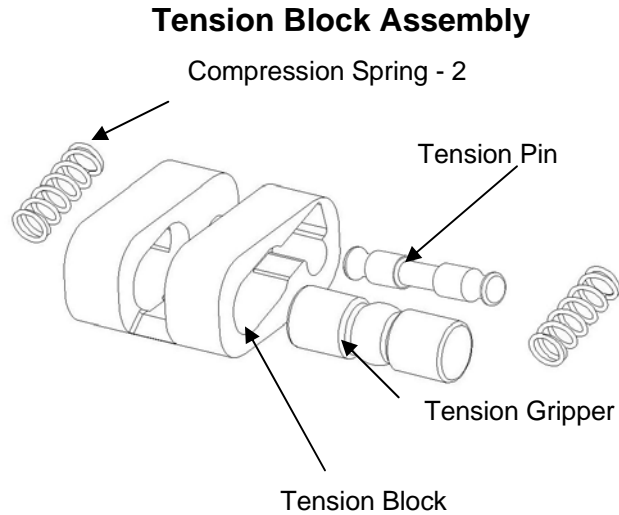
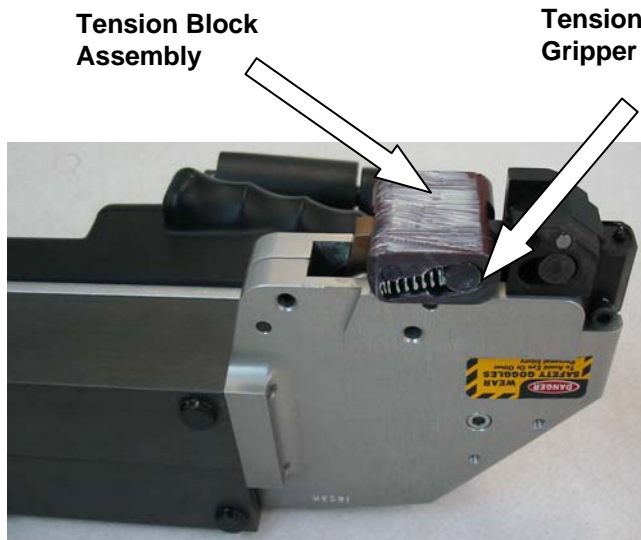

Tension Block Assembly, inspection and parts replacement:

Disassembly:

- Lift and remove the Tension Block Assembly from the notch on the Tension Arm.
- Push out the Gripper. remove the loose Gripper Springs.
- Push out the Gripper Pin.

Inspection:

- Inspect and replace the Tension Block if worn.
- Inspect and replace the Tension Gripper if worn.
- Inspect and replace the Gripper Pin if worn.

Reassembly:

- Lubricate the Gripper surfaces as shown on **page 28**.
- Install the Gripper in the Tension Block.
- Lubricate the Tension Pin surfaces as shown on **page 28**.
- Install the Gripper Pin in the Tension Block.
- Reinstall the Gripper Springs.
- Reinstall the Tension Block Assembly. Be careful to engage the Tension Block Pin with the notch on the Tension Arm.
- Lubricate the Maintenance Flip Cover as described on **page 28**.
- Reinstall the Maintenance Flip Cover and insert Quick Release Pins.
- Tension the Flip Cover Tightening Screw (12-15 in-lbs) to complete reassembly.

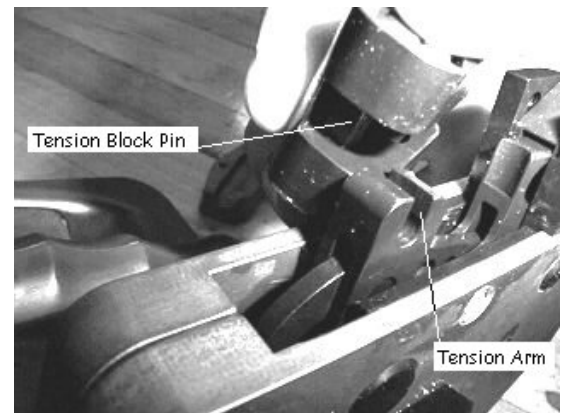

Tool Punch Height:

The punch can be checked for excessive wear and damage by measuring the height it extends above the knife surface. To do this follow the directions listed below.

1. Pinch the line coming from the tension regulator on the controller module and depress the tool trigger. This will activate the cut-off and extend the knife assembly.
2. Thoroughly clean the punch tip and knife surface so that both are free of debris.
3. Measure the height that the punch sticks out above the surface of the knife.
4. When the punch height drops below .120" (3.18mm), or shows evidence of chipping, replace the punch and/or knife.

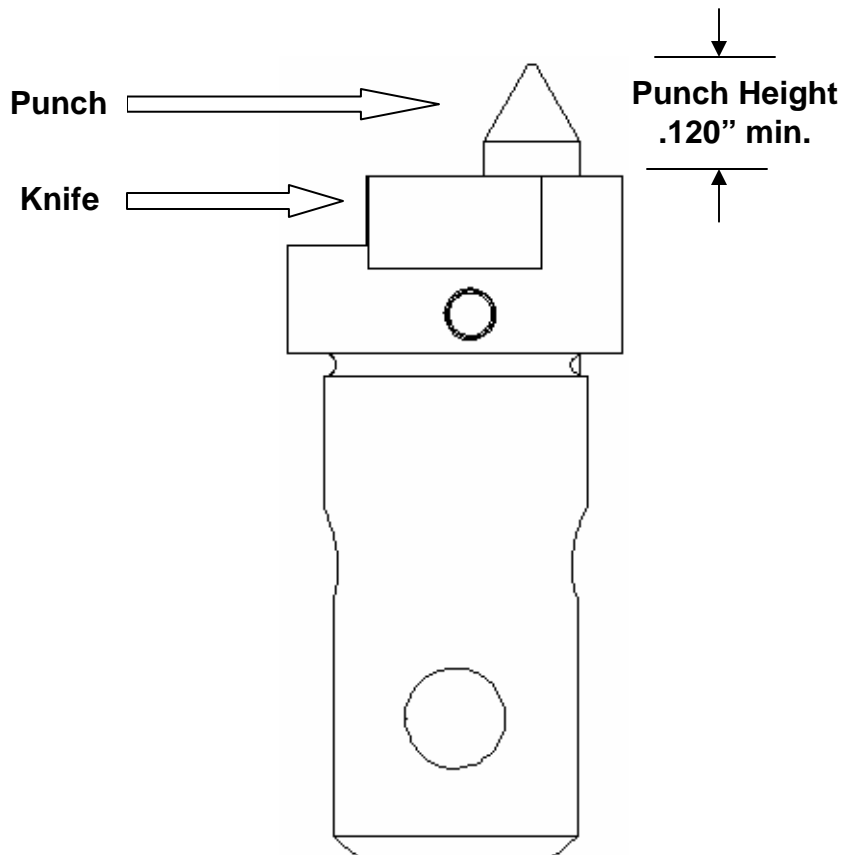

- Remove the Maintenance Flip Cover. Examine all moving parts and linkages for wear.
- Using an air nozzle, gently clean the parts of any dirt and metal filings in the tensioning cavity.
- Using cotton swabs or a short bristled brush, continue to wipe away any foreign debris and purge once again with the air nozzle.
- After thoroughly cleaning all moving parts, re-lubricate all surfaces. Following are lubrication instructions.
- For mechanical parts lubrication use a synthetic gel lubricant containing Teflon.

Procedure for disassembly to clean and lubricate the mechanical linkage points

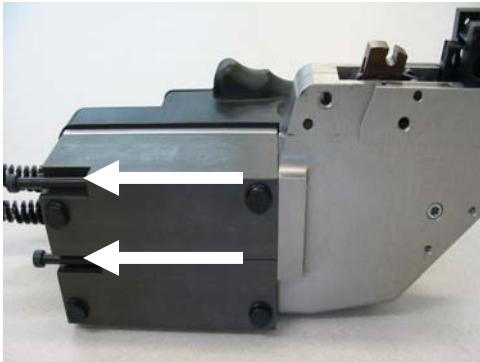

- 1) Remove the two screws located at the back of the cylinders. Remove third screw holding the side bodies together. Holding the tool in place, gently lift the side cover exposing the mechanical linkage. This side cover is a close fit and may require a slight rocking motion to separate the cover from the tool.



- 2) a) Examine the linkage for over-all condition such as dirt, metal filings, liquid contamination and lubrication.
b) Examine the upper cylinder (tension cylinder), for evidence of air leaks, noted by residue around the piston.
- 3) Clean tool cavity, including tool body, linkage, and already removed tool cover.

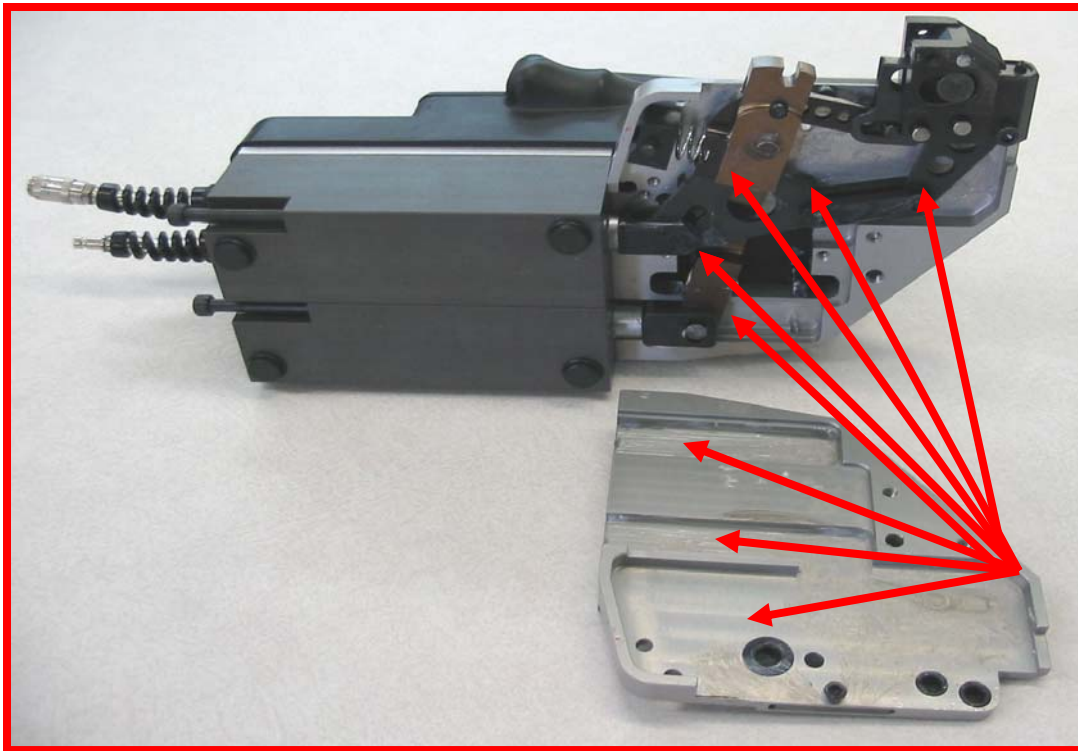

- 4) Lubricate the removed cover as shown with red arrows above. Also, lubricate the tool body, linkage and Tension Block Assembly as shown on **page 28**.
- 5) Inspect all mechanical linkage for lubrication, proper placement and refit cover.
- 6) Secure the tool side cover by inserting and tensioning (2) #10 – 32 X 4" length cap screws through the Cylinder Housing and into the Cover. Apply a light dab of red Loctite thread loc to one or two threads to prevent loosening during operation.

Lubrication – Follow recommended intervals – Use a synthetic gel lubricant containing Teflon for the internal parts as shown and described. Lubricate all pivot points and internal surfaces of maintenance flip cover with a light coating of the lubricant.

Caution – Excessive amounts of lubricant may result in gripper slippage, requiring a full repeat of cleaning process.

Lightly lubricate all points indicated with red arrows.

Maintenance Flip Cover every 12,500 cycles



Tool mechanics every 25,000 cycles

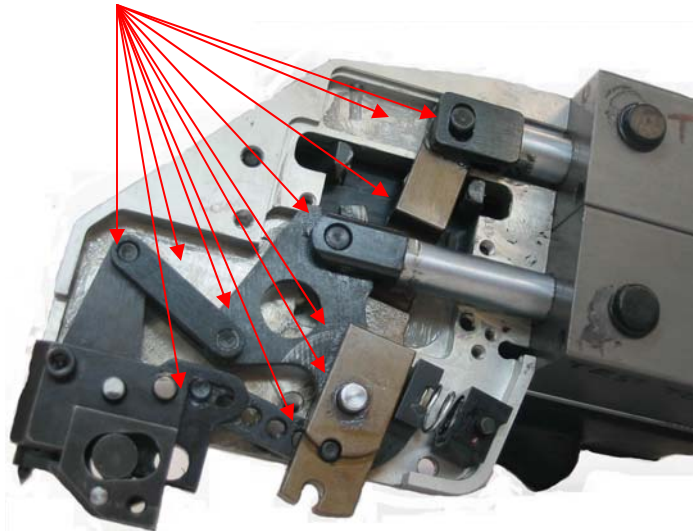

After the Maintenance Flip Cover is cleaned, lubricated, installed and Quick Release Pins are in place, apply tension to the Maintenance Flip Cover Tightening Screw. Torque to 12-15 inch lbs. Refer to pages 5, 18.

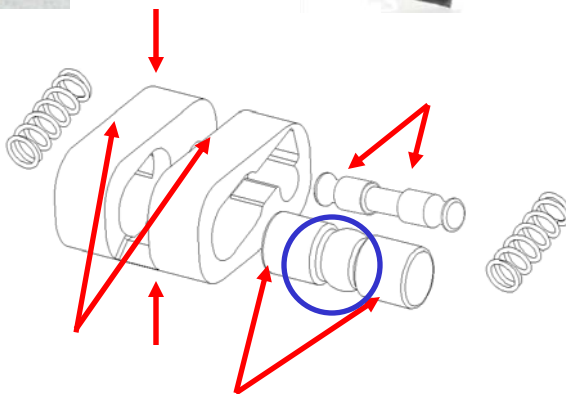

Tension Block Assembly every 12,500 cycles

Note: Ensure no lubrication is present in the center of Gripper. (indicated by the blue circle)

Procedure to adjust the timing of the clamp tail cut-off:



Additional information on timing, **page 31**.

The Timing Valve will be affected over time by contaminants in the air system. Moisture, dirt particles, oil and solvents can cause blockage or fluctuations in the tool performance.

Cut-off timing set too fast will not allow the clamp to achieve the desired tension before switching to the cut-off function causing a loose clamp. Cycle should be .9 – 1.3 seconds.

Cut-off timing set too slow may slow production and cause operator to twist the tool during application. This may damage tool.

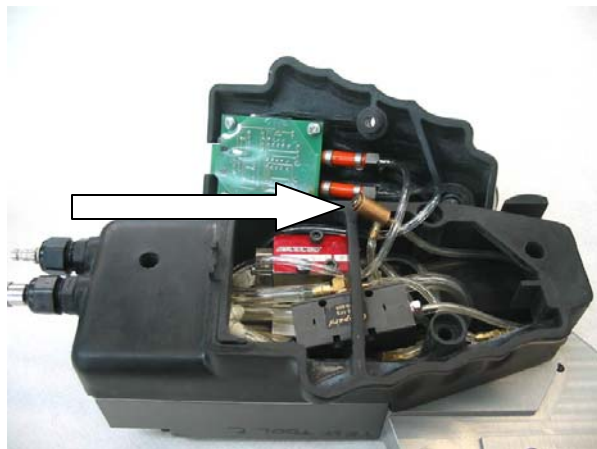

Procedure:

- 1) Remove the two cap screws in the Handle Cover with a 9/64" hex key. Remove cover and lay aside. Cap screws are of different length, note their position during their removal.
- 2) The Brass Needle Valve used to adjust timing is highlighted in view to the left.
- 3) To adjust: Hold the valve in position being careful not to kink tubing inside tool. Start by gently turning the Adjusting Valve Screw clockwise until snug. Back out the Adjusting Screw counterclockwise 1 1/2 turns. This should be the proper setting, yielding a .9-1.3 second delay.
- 4) To test and verify proper adjustment: Connect the tool to the Air Control Module, then turn supply valve on. Gently kink the coiled air supply tube connected to the bottom Quick Connect Air Coupling (top photo), then activate the Tool Trigger. This action causes the tool to cut off, allowing the timing to be reviewed. Adjusting the Timing Screw in by 1/2 turn will slow the tool's cut-off action. Adjusting the Timing Screw out by a half turn increases the speed of the cut-off activation. Repeat this entire step until timing is set at a .9 – 1.3 second delay. **Caution: Setting timing to less than .9 may result in loose clamps.**
- 5) See **page 34** for alternative procedural information.

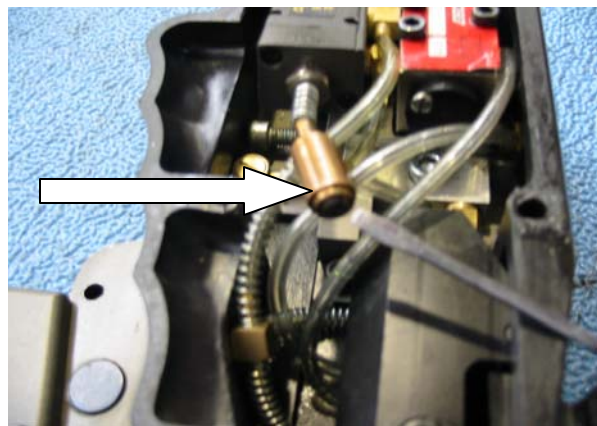

Tension Cylinder Pressure Monitoring System



XIT6000-CA 3/8" Tie-Lok® Tool



The Tension Cylinder Pressure Monitoring System provides an indication, but not confirmation, of clamp tail tension by transmitting a pressure reading from the Tension Cylinder via a Pressure Transducer. The transducer signal is recorded when the Cut-off Cylinder begins to move. The Cut-off Cylinder begins to move when the tool has reached maximum tension. The force applied by the tension cylinder is calculated from the transducer signal. The Monitoring System also provides a gateway to pass the number of completed cycles of both the tension and cutoff cylinders to the data collection device. Data, in ASCII format, from the Monitoring System is sent via an RS-232 serial port to a Data Collection Device (not part of the monitoring system).

The Tension Cylinder Pressure Monitoring System consists of: 1) Breakout Box with reset switch, one each green, red, and yellow LEDs, RS232 port, Data Connector, Power Input, and Signal Output (9V Out, 3.5mm phono jack) 2) 9VDC Power Supply 3) RS232 Cable, approx. 10 ft length 4) 15 foot Data Cable.

Initial Set Up:

- Secure the Breakout Box away from shock and vibration.
- Connect the Serial Cable from the Breakout Box to the Data Collection Device, (e.g. Computer)
- Connect the 8 wire, Ethernet Cable to the receptacles on both the tool and Breakout Box.
- If desired, the "9V Out" signal output on the Breakout Box can be connected to a customer supplied device. The signal could be used to shut off air supply to the tool should the monitoring system indicate force is out of range.
- Plug the 9VDC power supply into a 120VAC 60Hz wall outlet and the cable to the power connector on the Breakout Box.
- The green LED indicator on the Breakout Box should be lit indicating the system is ready to monitor the Tension Cylinder pressure.
- If the yellow LED indicator is lit this indicates the tool has not been detected. Insure the Data Cable is connected and routed away from sources of electrical noise.
- For information on data capture, refer to **page 32**.
- To verify tool cut-off timing, refer to **pages 29, 34**.

Tension Cylinder Pressure Monitoring System



XIT6000-CA 3/8" Tie-Lok® Tool

Operation:

- When the system calculates a force outside the predetermined range the red LED will be lit, error message will be appended to output data string, and the voltage at the "9V Out" signal output will change from 9 VDC to 0 VDC. This condition could be caused by: tension pressure set incorrectly, an air leak in the tool, cut-off timing set too short, or low air supply volume to the tool.
- Correct the problems as required and cycle the tool by installing a clamp or using the M28090 device. If the red LED is still lit, continue to look for and correct problems related to the air system.
- Note: Pushing the Reset Button on the Breakout Box will clear an error, return the LED to green, and reset the voltage at the signal output to 9 VDC. This is not normally needed, unless the 9V out directly controls a shutoff device to the tool. See **page 35** for additional means to reset the tool.
- When the breakout box first detects a connected tool, it will output the tool information: Total number of cycles and tool serial number.

Example of Data Output:

Program: X75301 *Revision: C

Clamp #	PSI	LBF	Tool #	Error
30			11111	
31	69.0	359	11111	
32	64.8	337	11111	
33	58.1	302	11111	LOW
34	72.7	378	11111	HIGH

- The suggested operating range is 333-368 LBF.
- LBF = The calculated force applied to the clamp tail +/- 15 LBF.
- **Example:**
- Clamp number 33 shows a low output and clamp number 34 shows a high output for this example.
- Clamp number 30 shows output when tool is first connected.
- ***Note:** Tool display should be Revision C. Earlier versions can be easily upgraded, contact BAND-IT Engineering.
- Actual ASCII output, items in [] are output only if an error is detected: (cycle number) 9 (Pressure) 9 (Force) 9 (serial number) [9 (error)] 10 13

Tension Cylinder Pressure Monitoring System



XIT6000-CA 3/8" Tie-Lok® Tool

Data Capture:

The XIT6000-CA Tension Cylinder Pressure Monitoring System can be used with many Data Capturing Devices including any computer with Windows operating software.

- Any properly equipped tool will work with any XIT6000 data breakout box. The tool's serial #, clamp count and settings remain with the tool and will be detected by any breakout box.
- Any software or hardware that can read the stated format can be used to collect data as it is sent from the tool.
 - (i.e. Hyper Terminal provided with Windows (Windows2000: Start – Programs – Accessories – Communications - Hyper Terminal). In settings, use the serial port the tool is connected to instead of a phone number. Under "Connect using:" select the port, typically COM1 or COM2. Using settings listed under specifications.)
- Updates or customizations to the XIT6000-CA program can be sent to the customer using a single executable file, no other software is required. Contact BAND-IT Engineering at 800-525-0758.

Specifications:

- Power: 110 VAC to 9 VDC wall supply adapter (6 ft wire provided)
- Pressure range: will detect 25 to 125 PSI
- Output: 9-pin RS-232 serial (approx 10 ft cable provided)
- Serial settings:
 - o 2400 Baud
 - o 8 bit
 - o No parity
 - o 1 stop bit
 - o ASCII formatted data
 - o No flow control
- Data format: Data columns (clamp number, PSI, estimated LBF and error if any) separated by tabs, each record separated by line feed / carriage return, (hard return)
- Data is sent at each clamp installation cycle
- Accuracy:
 - o PSI: +/- 1.0
 - o LBF: +/- 15

Trouble Shooting Guide for the Tension Cylinder Pressure Monitoring System:

No data output: Is power connected? Is the tool connected with a 8 wire Ethernet cable? Is the breakout box connected using a RS-232 serial cable? Null modem cables will NOT work with this device. Check all tool and device settings including pinched air lines inside tool housing and short cut-off timing adjustments. Some computer systems' ports, to which the Breakout Box is connected may be in use by another program. Close the program or try another port.

Data output is garbled: Check the settings on the data capture device. Maximum cable length can be 25 feet between breakout box and tool, maximum cable length between the breakout box and data capture location can be 50 feet. (For longer serial cable run, we suggest the use of a serial line amplifier).

Data output is garbled, or has false tool detection errors: Check for damaged cables. Check cable routing, this system can be affected by outside interference. Keep cable away from AC lines and other electrical noise generating sources.

Tool cycles, but no tool data is output: If the breakout box sends the header strings, but not tool data, *make sure the air lines inside tool handle are not pinched*. This can be verified by loosening the 2 handle screws and re-cycling the tool. Verify timing is properly adjusted, refer to **page 29**. Verify the cable connections and settings are correct and the tool is operating at correct tension cylinder pressure. This may indicate damage to the Ethernet cable, pressure transducers or the circuitry inside the tool.

Tool cycles and system reads normal reading and lighting but clamp is loose: Refer to this XIT6000-CA manual. See air pressure settings, cleaning, lubrication, preventative maintenance, parts replacement sections. Tool user is responsible for ensuring clamp application.

Cut-off Timing Verification Procedure

1. This procedure requires the use of the M28090 Calibration Device.
2. This procedure requires the programmed Breakout Box to be -REV B- or later. If the display on your tool is an earlier version, contact BAND-IT Engineering for a free upgrade to the latest revision. See page 30, "Example of Data Output"
3. Prepare tool by connecting the M28090 Calibration Device per instructions included with the device.
4. To switch the breakout box over to check cut-off timing, press and hold the reset button on the break out box 3-4 seconds. When the button is released, the green LED will begin flashing and the display will read "**Ready to check timing: Press Trigger**"
5. Press the trigger on the XIT Tool. The breakout box will output the measured cut-off timing.
Examples:
"Timing OK! Time = 1.01 sec"
"Warning! Time = .91 sec"
"Timing Error! Time = .80 sec"
6. The green LED will light and remain solid if the timing is well within the suggested range. The yellow LED will light if the timing is approaching the limits of the suggested range; timing is OK, but may need to be adjusted soon. The Red LED will light if the timing cycle is set too short or too long. Follow instructions on **page 29** for adjustments and re-check.
7. Press the reset button on the XIT6000 tool and the breakout box will reset, flashing the green LED and be ready to check the timing again.
8. To switch from timing check mode to normal program operation, press and hold the reset button on the breakout box for 3-4 seconds.

Note: The program will not switch into or out of timing mode unless it detects an attached tool.

Connections and Pinouts:

1. Data cable connection between tool and breakout box:

8-pin, 15 ft long, CAT5e cable provided. This cable carries both 12 VDC and 5 VDC power, and 5 digital lines. Using a cable longer than 25 ft will degrade the signal and may cause the tool to incorrectly report pressure readings.

Only connect the breakout box to the tool. *Never* connect either the tool or breakout box to any other device. Damage may occur to device, breakout box, or tool.

Before connecting the cable to the tool and breakout box, check for debris inside both connectors. On rare occasions, debris inside the connectors will cause a short, possibly damaging the electronics.

2. Serial connection:

9-pin, approx 10 ft long, straight RS232 serial cable provided. *Do not* use a null modem cable. (pins 1, 8 and 9 are inactive)

Pin 2: Data is sent on this pin in ASCII format

Pin 3: Not needed for normal operation. This pin is used to reprogram the breakout box and needs to be connected for program updates.

Pin 4: This pin controls the breakout box reset and programming. Changing the state of the this pin from low to high will force a reset on the Breakout box. If needed, this can be used to clear errors.

Pins 6 and 7: Connected internally

See Figure for Pin Assignments:

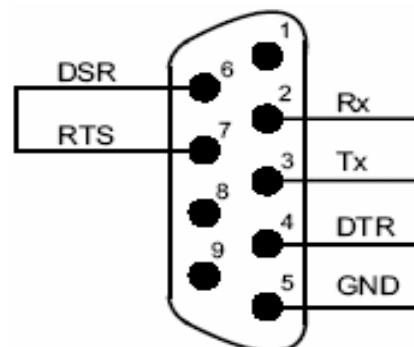

3. 9V signal out:

3.5mm mono jack provided on breakout box.

Maximum current: 100 mA

Tension Cylinder Pressure Monitoring System



XIT6000-CA 3/8" Tie-Lok® Tool

(Example of data collection using a Windows XP Operating System)

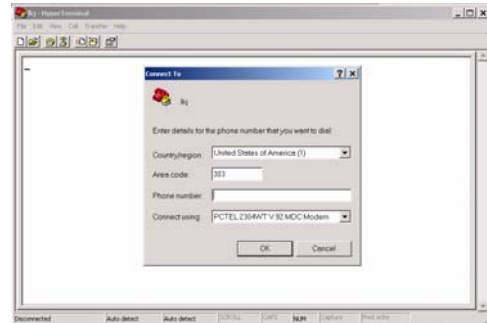
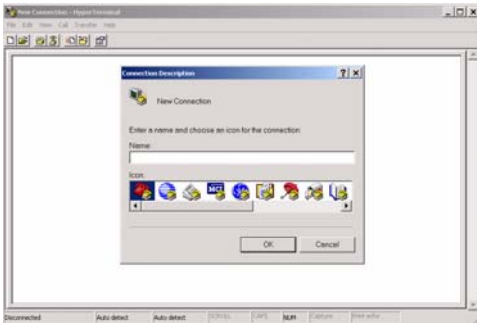

1. Begin with Start Menu: \Programs\ Accessories\Communications\HyperTerminal
2. Type a connection name.
3. Click OK

4. "Connect to" dialog box appears
5. In the "Connect Using" text box, choose COM1, Click OK

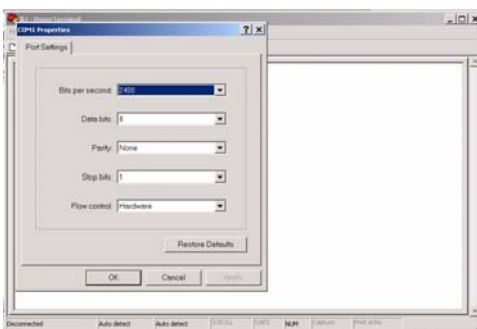

6. Properties dialog box appears
7. Port Settings should be:
 - Bits per second (2400)
 - Data bits (8)
 - Parity (None)
 - Stop bits (1)
 - Flow control (NONE)

8. Hook up control box, two lines of header information will appear on the screen: Program / clamp, etc. Upon connection, the current clamp information and tool serial # will appear. Tool is now ready.
9. To capture data- click Transfer, then click Capture Text, enter a file name and location, then click Start. ***NOTE!** *Data will not be saved unless "stop" is selected from this same menu.

Click OK

To check the cut-off delay timing, hold down the reset button on the breakout box for 3 seconds. You will see "Ready to check timing" appear on the screen. Activate the tool and it will display the delay duration in decimals of seconds. Hold down reset button for 3 seconds to return to main menu. See page 34.

Tool Calibration



XIT6000-CA 3/8" Tie-Lok® Tool

BAND-IT's use of the word calibration refers to the tool's electronic output being checked against a load measuring device. This is to insure that the electronic calculation of the output force based on the supply pressure is still matched up with the actual output force of the tool. To measure the actual output of the tool, BAND-IT has developed a Calibration Device (M28090). Call BAND-IT for more information.

The Calibration Device is installed onto the tool in place of the flip cover. The tension block of the tool presses up against the load cell on the calibration device when the trigger of the tool is depressed, allowing the tension force to be captured. The force is displayed on the readout. The direction of the tension force is shown by the white arrow. See the M28090 manual for further information.

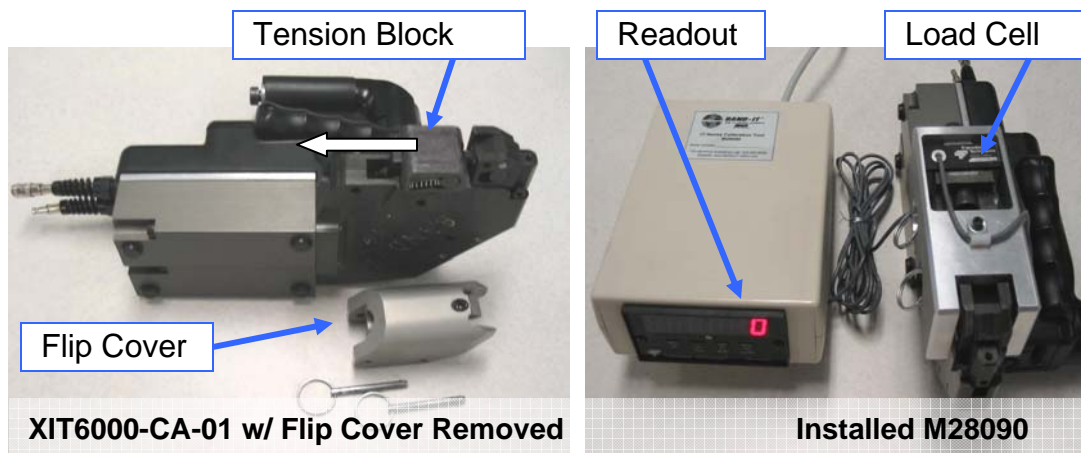

To check the calibration of the tool, attach the M28090 calibration device at the tool's regular location. This will ensure that the data represents the performance of the tool under normal operating conditions.

Once the M28090 is attached to the tool, hook up the air supply and actuate the trigger. The M28090 will then display the tension force in the tool. The target tension force of this calibration is 351 lbf, so the Tension Air Pressure of the Air Controller Module will have to be adjusted (ensuring it remains within 60 to 75 psi) between tool cycles until the target of 351 lbf is achieved. The tool may have to be reset and actuated several times before the target point is reached.

Tool Calibration



XIT6000-CA 3/8" Tie-Lok® Tool

Once the target tension force is attained, the value on the computer display screen should be within ± 15 lbf of the M28090 readout. Operation of the tool can begin if the difference between the 2 readings is less than 15 lbf and within specifications (Ford Engineering Specification of 334 to 368 lbf). These readings must be repeatable. If the difference between the 2 readings is greater than 15 lbf, the tool needs to be sent to BAND-IT-IDEX, Inc. for repair. Over a period of time, the 2 readings are likely to drift apart, but they must remain within 15 lbf.

Once calibration is complete, press the tool reset button to release the force and then remove the calibration device. Be sure to clean and lubricate the maintenance cover before reinstalling the cover on the tool and inserting the Quick Release Pins shown on **page 5**.

BAND-IT-IDEX, Inc.
A Unit of IDEX Corporation

4799 Dahlia Street Denver, CO 80216-3070 USA

P: 1-800-525-0758 F: 1-800-624-3925



WWW.CABLEJOINTS.CO.UK
THORNE & DERRICK UK
TEL 0044 191 490 1547 FAX 0044 477 5371
TEL 0044 117 977 4647 FAX 0044 977 5582
WWW.THORNEANDDERRICK.CO.UK