

Warning: Always wear safety glasses when operating tool.

UL2000, UL4000, UL9000, UL9010 Ultra-Lok Tools:

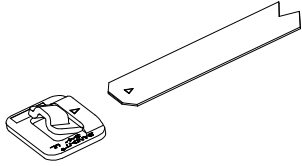

1. Break off an Ultra-Lok Free-End tie from the roll. Slide the buckle onto band with indented arrows pointing in same direction and same side up. Slide buckle all the way onto band until it comes to a stop between the two buckle dimples at opposite end of tie.

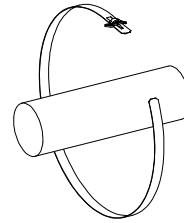

2. wrap tie around object to be clamped. Insert the tie through buckle once for single-wrap or twice for double-wrap.



3. If desired, you may pre-form a clamp in the same fashion as step 2.

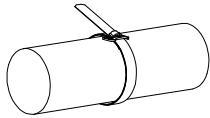

4. Position the tie on the object you are clamping. Pull the wrapped tie hand-tight.

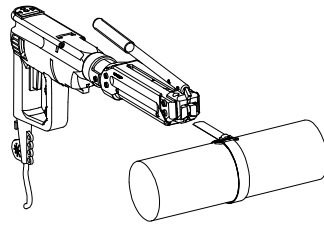

Prepare Band-It Ultra-Lok tool for operation as described in owners manual. With cut-off handle down as shown, insert clamp tail into tool head slot.

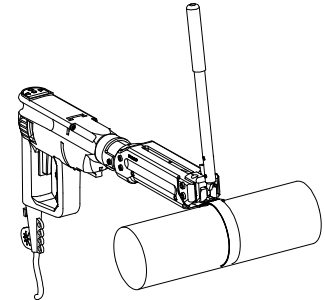

5. Operate tool until proper tension has been applied. Lift the cut-off handle to cut tail off and form a lock. Excess band can be removed by pulling out from rear of tool or reversing the drill.

6. Completed clamp should appear as shown.

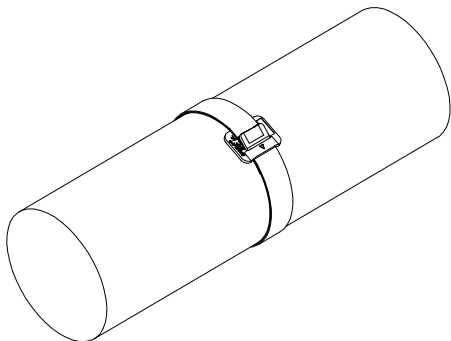

Tap down buckle for proper function

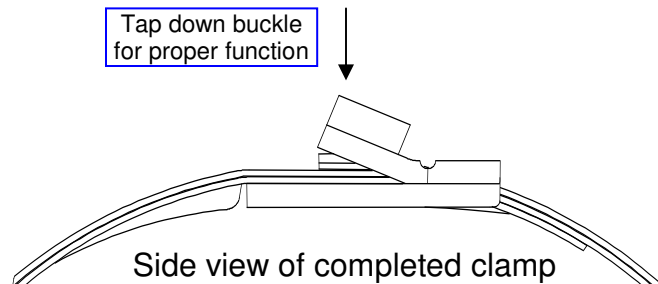

Inspect buckle on completed clamp and tap down buckle shroud.

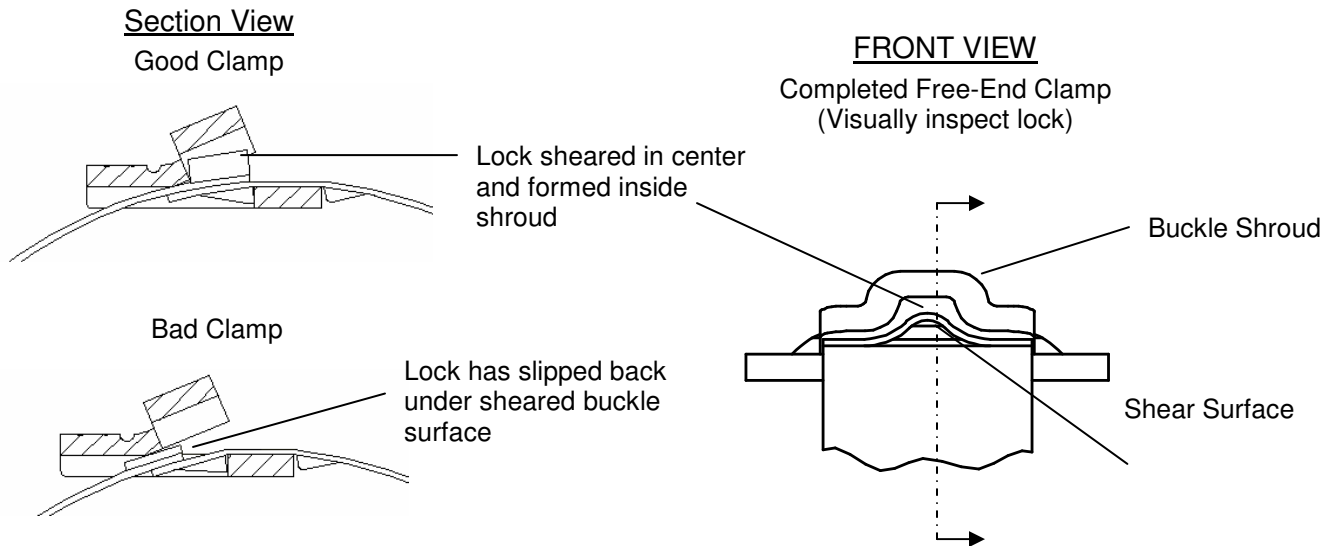

Important: Visually inspect lock formed in band as shown. If lock has slipped under the sheared surface of the buckle, remove clamp and install a new one at reduced tension by lowering the drill clutch torque setting.

Band and Buckle Totes:

If band end is not accessible, rotate roll band diameter through handle until end snaps into opening.

Line up 4 tabs on outside of buckle box with 4 slots in tote. Press into tote.

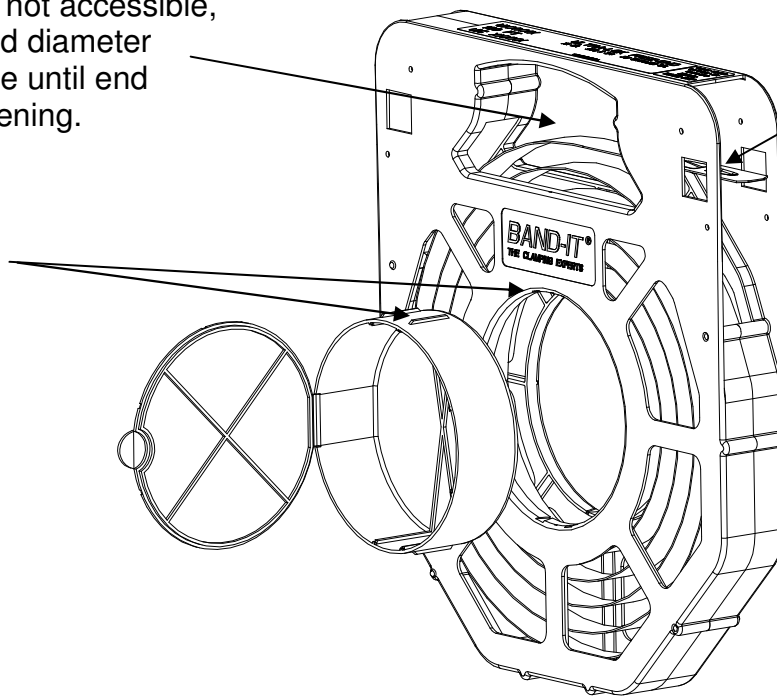

Warning:
For safety purposes, retract band until end is between tote side walls.