

Introduction:

The T30069 Center Punch Tool installs BAND-IT 3/8" and 5/8", 201 Stainless Steel and Galvanized Carbon Steel clamps.

Table of Contents:

1. Introduction & Safety Practices
2. Operating Instructions
3. Tool Assembly
4. Repair Parts List
5. 3/8" Adapter & Warranty

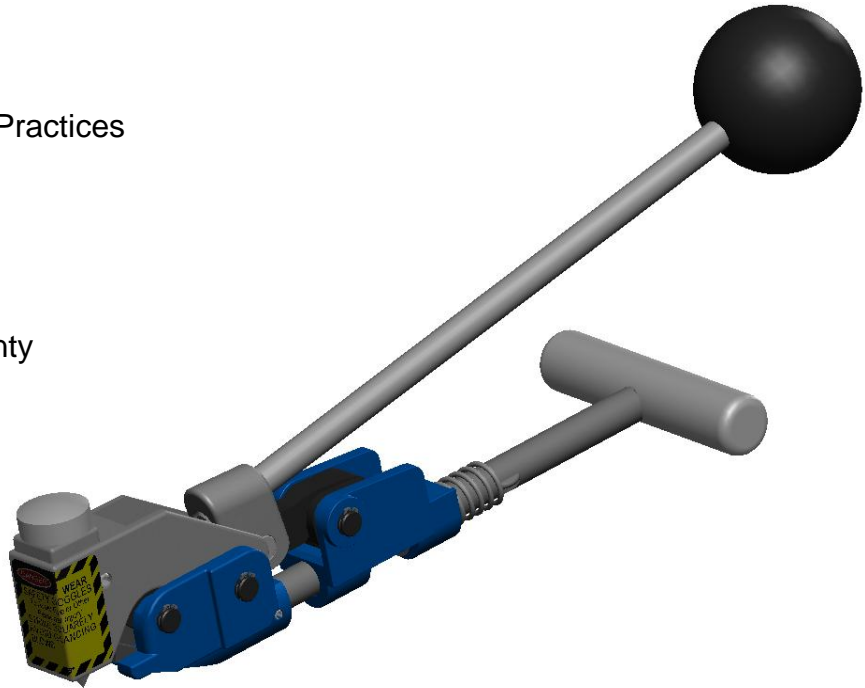

Safety Practices:

1. Read this manual and become familiar with the tool before use.
2. Protective eyewear should be worn during use.
3. Wear appropriate gloves for handling steel.
4. When applying clamps, care should be taken to insure fingers are not in contact with the clamp during installation.
5. Never attempt to clamp objects which have the potential to burst, shatter or otherwise cause bodily harm.
6. Do not use tool on live electrical sources.

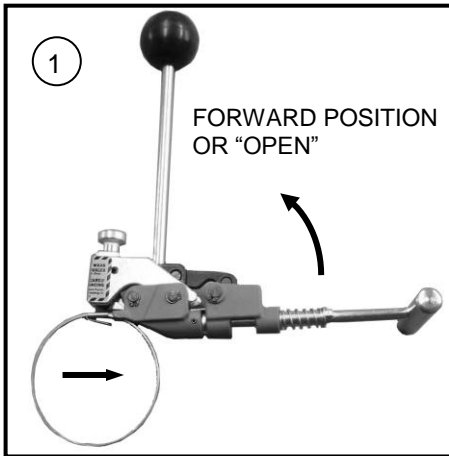

LOAD CLAMP

Push tension handle all the way forward. Insert BAND-IT Center Punch clamp tail and push all the way into tool.

Tool Tip: To apply 3/8" wide clamps, use S03289 adapter kit. See attached instructions for 3/8" adapter.

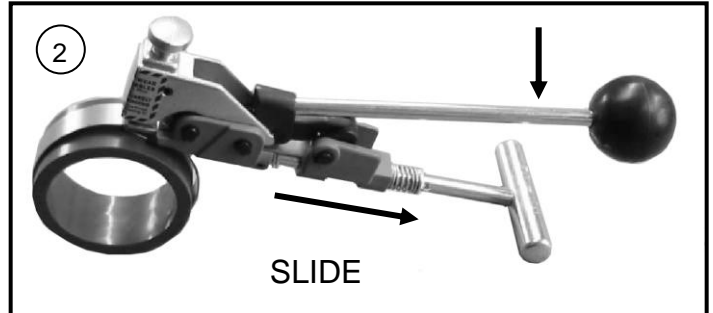

TIGHTEN CLAMP

Tighten the clamp with short downward strokes. Tension handle should be in down position at completion of tightening clamp.

Note: Do not lift tension handle too high as it may open up buckle pusher, resulting in improper clamp application.

If clamp tension needs to be released before locking, move handle forward and move slide back against spring. This raises pulling dog and releases clamp tension.

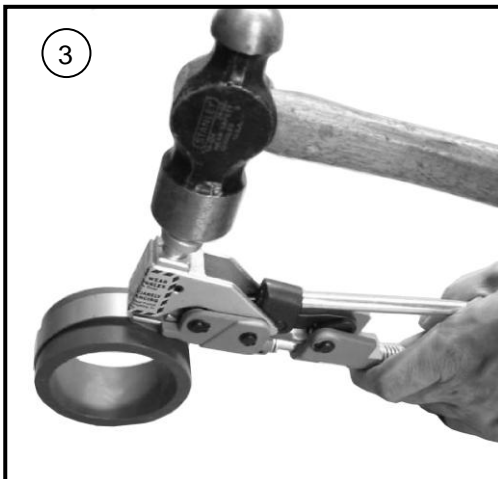

LOCK CLAMP

Holding tension handle down, lock clamp by hitting punch at least twice with 2 lb. Mallet.

Note: Only use genuine BAND-IT Center Punch clamps. Disregarding this may result in substandard clamps or tool failure. BAND-IT CP clamps are made out of Type 201 Stainless Steel or Galvanized Carbon Steel material with a stainless steel buckle for added strength.

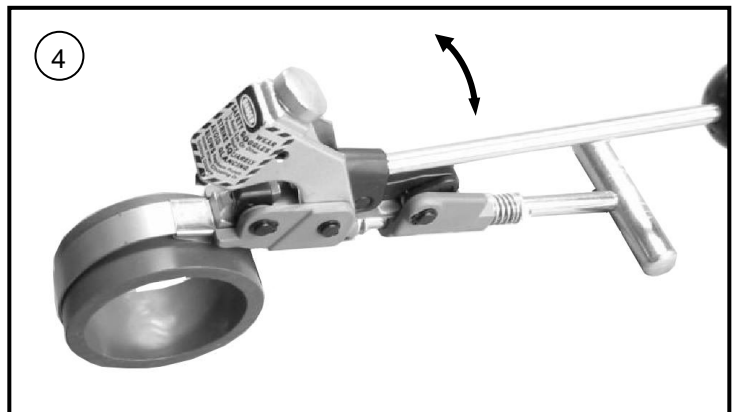

REMOVE CLAMP TAIL

Hold work-piece and pivot the tool back and forth to break off clamp tail. Remove tail from tool by operating tension handle. When tail has moved through holding dog, raise tension handle and pull tail free.



REPAIR PARTS LIST FOR T300

| NO. | PART NUMBER | DESCRIPTION |
|-----|-------------|---|
| 1 | A04987 | COMPRESSION SPRING, 5/8" DIA. |
| 2 | C09787 | SPRING PIN, 1/8" DIA. |
| 3 | J64287 | HEAD SPRING PIN |
| 4 | S03289 | ADAPTER INSERT TO INSTALL 3/8" WIDE CENTER PUNCH CLAMPS (OPTIONAL) |
| 5 | S05777 | BUCKLE PUSHER |
| 6 | S05887 | HOLDING DOG |
| 7 | S06887 | PIN, PULLING/HOLDING DOG |
| 8 | S06987 | PIN, HEAD PIVOT |
| 9 | S08387 | RETAINING RING, 5/16" DIA. |
| 10 | S19087 | PUNCH |
| 11 | T25287 | PUNCH HOLDER |
| 12 | T25587 | RETAINING BALL, 5/32" DIA. |
| 13 | T25987 | DECAL, DANGER |
| 14 | T26487 | SPRING, HOLDING DOG |
| 15 | T26787 | DOWEL PIN, 5/16" DIA. |
| 16 | T27040 | SLIDE |
| 17 | T27187 | PULLING DOG |
| 18 | T27288 | LINK |
| 19 | T27488 | HEAD |
| 20 | T27988 | TENSION HANDLE ASSEMBLY |
| 21 | T28687 | SLIDE BAR AND TENSION HANDLE ASSEMBLY |
| 22 | T28740 | NOSE |
| - | T28088 | HEAD ASSEMBLY INCLUDES: HEAD SPRING PIN, DANGER DECAL, HEAD, PUNCH, RETAINING BALL, AND PUNCH HOLDER |
| - | T28888 | NOSE AND SLIDE ASSEMBLY INCLUDES: NOSE, SLIDE, COMPRESSION SPRING, HEAD SPRING PIN, AND SLIDE BAR AND TENSION HANDLE |
| - | T32190 | PUNCH KIT INCLUDES: PUNCH, PUNCH HOLDER AND RETAINING BALL |
| - | T32290 | GRIPPER KIT INCLUDES: PULLING DOG, COMPRESSION SPRING X 2, RETAINING RING X 3 AND HOLDING DOG |

3/8" Adapter & Warranty



T30069
CP Hand Tool

1. To convert T300 center punch tool, rotate head back to expose buckle pusher and nose of tool.
2. Press down on the lobe at the rear of the buckle pusher to raise the front portion for insertion of adapter between the buckle pusher and the nose.
3. Seat the adapter against the buckle pusher with the post of the adapter hooked at the rear of the triangle shapes of the buckle pusher. Release the pressure on the buckle pusher lobe to secure the adapter into place. Rotate the head forward. The tool is now ready to use.
4. Repeat instructions 1 and 2 to remove adapter.

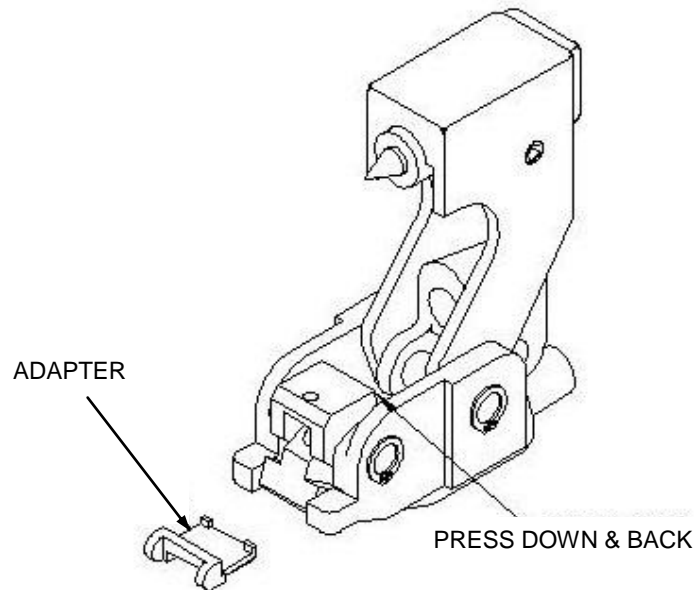

Warranty:

For Warranty information, visit the following URL

www.BAND-IT-IDEX.com/Warranty.html