

Installation Instructions



J93099 Cutter Blade Kit

J93099 Kit Installation Instructions for Cutter blade and Backing Plate

Components of this kit are a dimensionally matched set. You may have parts that look similar, but they are different dimensionally if received before May 1st, 2004. Parts received before May 1st, 2004 should be discarded.

1. Remove old cutter blade screws, cutter blade and backing plate and discard.
2. See illustrations to determine the correct positions for component assembly.
3. Hold cutter blade and backing plate together, insert screws and tighten to 8-14 ft-lbs.
4. Choose the correct length bolts supplied in this kit for your tool. Fully tensioned bolts should flush or extend beyond the cutter blade ¼" max.

Operating Tip: Keep the bolts tight (8-14 ft-lbs.). A loose bolt may cause cracking or premature wear of the cutter blade and/or backing plate. This could result in improper clamp tensioning, locking, and cutting.

Operating Tip: Keep the leading edges of the cutter blade and backing plate free of metal shavings. Metal shavings will result in clamp band gouging during tensioning. **Clean and hone the leading edges by hand. Do not use power tools. Honing should polish surfaces, not remove material.**

BAND-IT-IDEX, Inc.
A Unit of IDEX Corporation
4799 Dahlia Street
Denver, CO 80216-3070 USA
P: 1-800-525-0758
F: 1-800-624-3925

www.BAND-IT-IDEX.com

Page 1 of 2

Document # P15488 Rev. D
© Copyright
BAND-IT-IDEX, Inc. 2007
All rights reserved

Installation Instructions



J93099 Cutter Blade Kit

J93099 Kit Installation Instructions for Cutter blade and Backing Plate

Components of this kit are a dimensionally matched set. You may have parts that look similar, but they are different dimensionally if received before May 1st, 2004. Parts received before May 1st, 2004 should be discarded.

1. Remove old cutter blade screws, cutter blade and backing plate and discard.
2. See illustrations to determine the correct positions for component assembly.
3. Hold cutter blade and backing plate together, insert screws and tighten to 8-14 ft-lbs.
4. Choose the correct length bolts supplied in this kit for your tool. Fully tensioned bolts should flush or extend beyond the cutter blade ¼" max.

Operating Tip: Keep the bolts tight (8-14 ft-lbs.). A loose bolt may cause cracking or premature wear of the cutter blade and/or backing plate. This could result in improper clamp tensioning, locking, and cutting.

Operating Tip: Keep the leading edges of the cutter blade and backing plate free of metal shavings. Metal shavings will result in clamp band gouging during tensioning. **Clean and hone the leading edges by hand. Do not use power tools. Honing should polish surfaces, not remove material.**

BAND-IT-IDEX, Inc.
A Unit of IDEX Corporation
4799 Dahlia Street
Denver, CO 80216-3070 USA
P: 1-800-525-0758
F: 1-800-624-3925



WWW.CABLEJOINTS.CO.UK
THORNE & DERRICK UK
TEL 0044 191 490 1547 FAX 0044 477 5371
TEL 0044 117 977 4647 FAX 0044 977 5582
WWW.THORNEANDDERRICK.CO.UK

Page 1 of 2

Document # P15488 Rev. D
© Copyright
BAND-IT-IDEX, Inc. 2007
All rights reserved

Installation Instructions



J93099 Cutter Blade Kit

Hand Tools

Air Tools

1-3/4" long – S750, S100
2" long – S350

CAUTION: To prevent breakage, backing plate must be installed flush with cutter blade.

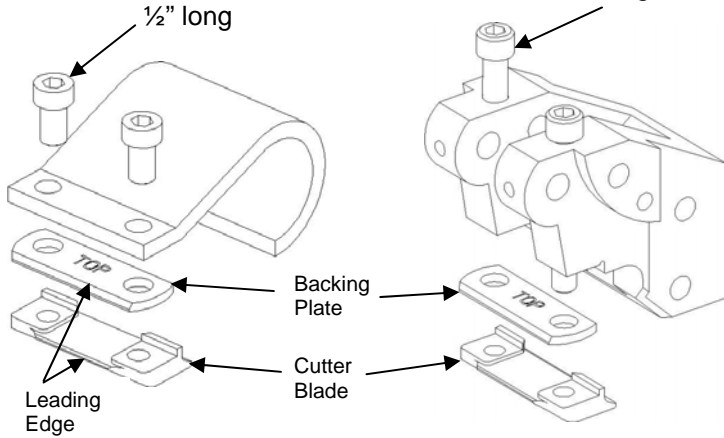

CORRECT

INCORRECT

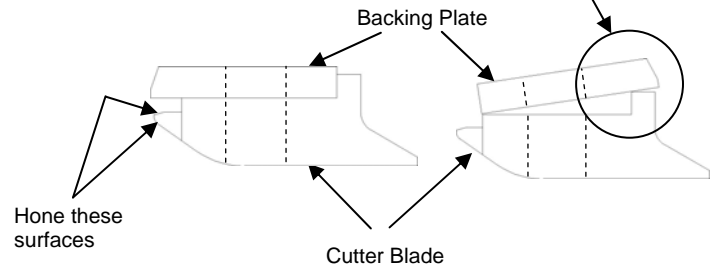

Rough edges on clamp band are indication of need to hone cutter blade.

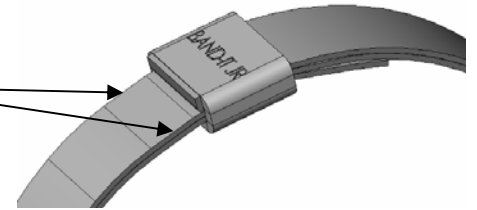

Installation Instructions



J93099 Cutter Blade Kit

Hand Tools

Air Tools

1-3/4" long – S750, S100
2" long – S350

CAUTION: To prevent breakage, backing plate must be installed flush with cutter blade.

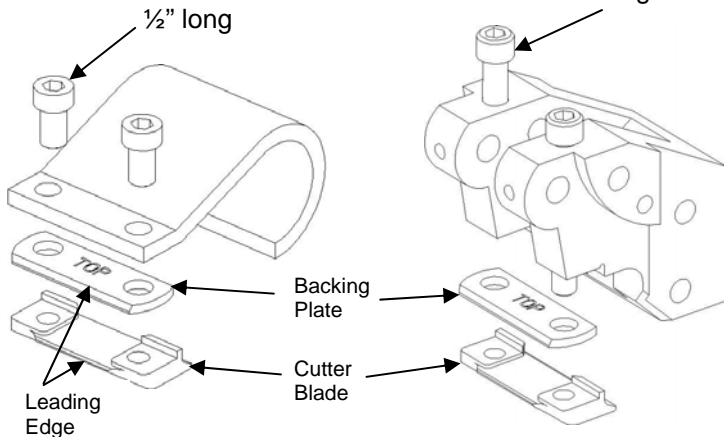

CORRECT

INCORRECT

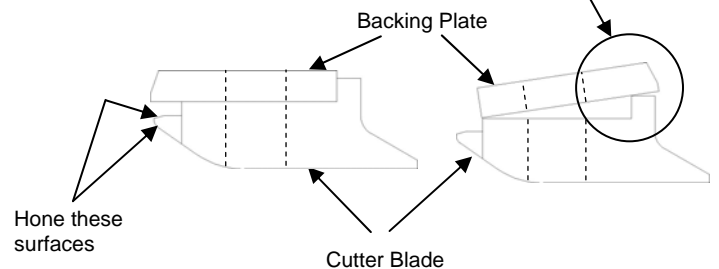

Rough edges on clamp band are indication of need to hone cutter blade.

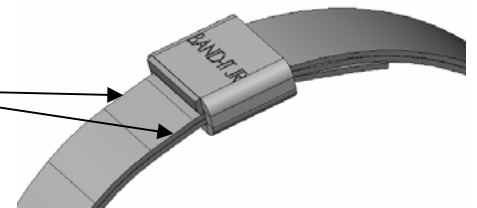

WWW.CABLEJOINTS.CO.UK
THORNE & DERRICK UK
TEL 0044 191 490 1547 FAX 0044 477 5371
TEL 0044 117 977 4647 FAX 0044 977 5582
WWW.THORNEANDDERRICK.CO.UK