

BAND-IT TENSION LIMITER

THE TENSION LIMITER IS AN ACCESSORY FOR THE BAND-IT C001 AND C002 TOOLS. IT CAN ALSO BE USED ON A C001 IN CONJUNCTION WITH A JUNIOR ADAPTOR. IT ALLOWS USERS OF THESE MANUAL TOOLS TO APPLY CLAMPS CONSISTENTLY WITH THE PROPER TENSION. THE TENSION LIMITER IS SET ONCE FOR A CERTAIN TYPE AND SIZE OF CLAMP. AS SUCCESSIVE CLAMPS ARE TIGHTENED, A PIN POPS OUT WHEN THE SAME FORCE IS ATTAINED, INDICATING THAT THE CLAMP IS TIGHT, BUT PREVENTING OVER TIGHTENING.

THE DEVICE IS ADJUSTABLE FOR BAND AND JUNIOR CLAMPS FROM 1/4" X .020 TO 3/4" X .030. THE UNIQUE TENSION LIMITER IS EASY TO OPERATE AND VERY REPEATABLE. IT WAS DESIGNED AS AN ANSWER TO MANY USER REQUESTS. IT PROVIDES CONSISTENCY AND REPEATABILITY IN AN AGE WHEN SAFETY AND LIABILITY ARE PRIME CONCERNS.

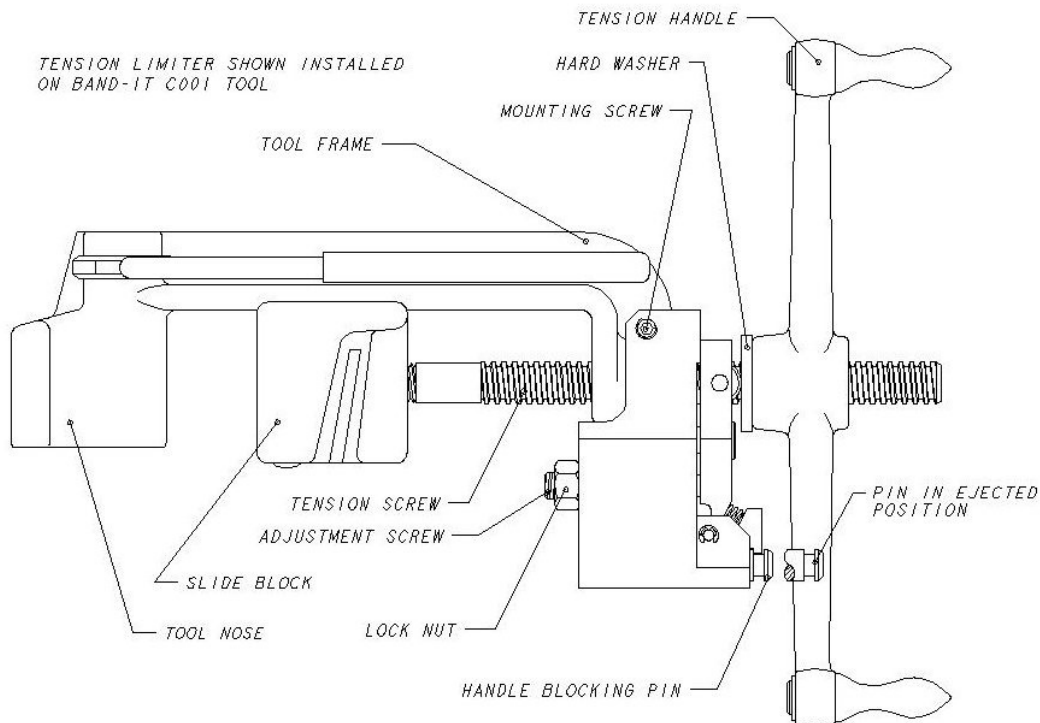

SEE INSTRUCTIONS ON REVERSE SIDE

PAT. NO. 5129350

Refer to website for warranty information: <http://www.band-it-idex.com/warranty.html>



WWW.CABLEJOINTS.CO.UK
THORNE & DERRICK UK
TEL 0044 191 490 1547 FAX 0044 477 5371
TEL 0044 117 977 4647 FAX 0044 977 5582
WWW.THORNEANDDERRICK.CO.UK

INSTALLATION:

1. REMOVE TENSION HANDLE AND THRUST BEARING FROM BAND-IT OR JUNIOR TOOL (THE THRUST BEARING IS NOT USED WITH TENSION LIMITER).
2. SLIDE THE TENSION LIMITER OVER THE TENSION SCREW WITH SLOT ON TENSION LIMITER ENGAGING RIB ON TOOL FRAME. SLIDE HARDENED WASHER OVER TENSION SCREW AND REINSTALL TENSION HANDLE. HARDENED WASHER MUST BE USED IN PLACE OF THRUST BEARING.
3. TURN TENSION HANDLE UNTIL SLIDE BLOCK PULLS AWAY FROM TOOL NOSE. SECURE TENSION LIMITER ONTO TOOL FRAME BY TIGHTENING BOTH SET SCREWS LOCATED ON SIDES OF TENSION LIMITER. TO INSURE PROPER SEATING OF TENSION LIMITER, PULL SLIDE BLOCK TOWARDS NOSE WHILE TIGHTENING SCREWS (USE 1/8" ALLEN WRENCH). AFTER INSTALLATION IS COMPLETED, MAKE SURE SLIDE BLOCK AND TENSION SCREW MOVES FREELY.

SETTING OF TOOL:

NOTE - TENSION LIMITER MUST BE SET UP FOR EACH SIZE AND TYPE OF BAND. AFTER IT IS SET, IT WILL APPLY ALL SUBSEQUENT CLAMPS WITH THE SAME TENSION. THE POINT WHERE THE MATERIAL STARTS TO STRETCH OR BREAK MAY VARY (ALL WITHIN BAND-IT'S STRICTLY MAINTAINED SPECIFICATIONS). THIS MAY REQUIRE RE-SETTING THE TENSION LIMITER.

1. LOOSEN JAM NUT AND TURN TENSION ADJUSTMENT SCREW CLOCKWISE WITH ALLEN WRENCH PAST THE POINT YOU WANT TO TIGHTEN THE CLAMP.
2. TIGHTEN THE CLAMP TO THE DESIRED TENSION. REMEMBER THAT A TIGHTER CLAMP KEEPS THE FITTING IN THE HOSE MORE SECURE, BUT EXCESSIVE TENSION COULD DAMAGE THE HOSE. IF IN DOUBT CONSULT THE HOSE OR FITTING MANUFACTURER OR CALL BAND-IT.

CAUTION: IMPROPERLY TIGHTENED CLAMPS MAY RESULT IN DANGEROUS HOSE ASSEMBLIES, WHICH COULD CAUSE INJURIES OR PROPERTY DAMAGE.

3. TURN ADJUSTMENT SCREW COUNTER-CLOCKWISE UNTIL PIN POPS OUT, STOPPING THE HANDLE. YOU NOW HAVE A ROUGH SETTING OF THE TENSION LIMITER.
4. REMOVE CLAMP AND RESET TOOL.
5. CHECK ADJUSTMENT AND FINE TUNE IT BY APPLYING A NEW CLAMP. TURN ADJUSTMENT SCREW CLOCKWISE TO INCREASE SETTING OR COUNTERCLOCKWISE TO DECREASE IT. WHEN YOU ARE SATISFIED WITH THE CLAMP TENSION PRODUCED, SECURE SETTING BY TIGHTENING LOCK NUT FIRMLY.

CAUTION: ABUSE OR USE OF A HOSE OUTSIDE MANUFACTURERS RECOMMENDED CONDITIONS, MAY CAUSE IT TO QUICKLY DETERIORATE AND BECOME A SAFETY HAZARD. THIS COULD RESULT IN SERIOUS INJURY OR PROPERTY DAMAGE. INSPECT AND TEST HOSE ASSEMBLIES FREQUENTLY. REPAIR OR REPLACE AT THE SLIGHTEST SIGN OF DAMAGE OR DETERIORATION.

SEE TOOL ILLUSTRATION ON REVERSE SIDE

PAT. NO. 5129350