



Introduction:

The C00369 Tool installs any BAND-IT Band of .030" thickness or less and 3/4" Giant Band of .044" thickness.

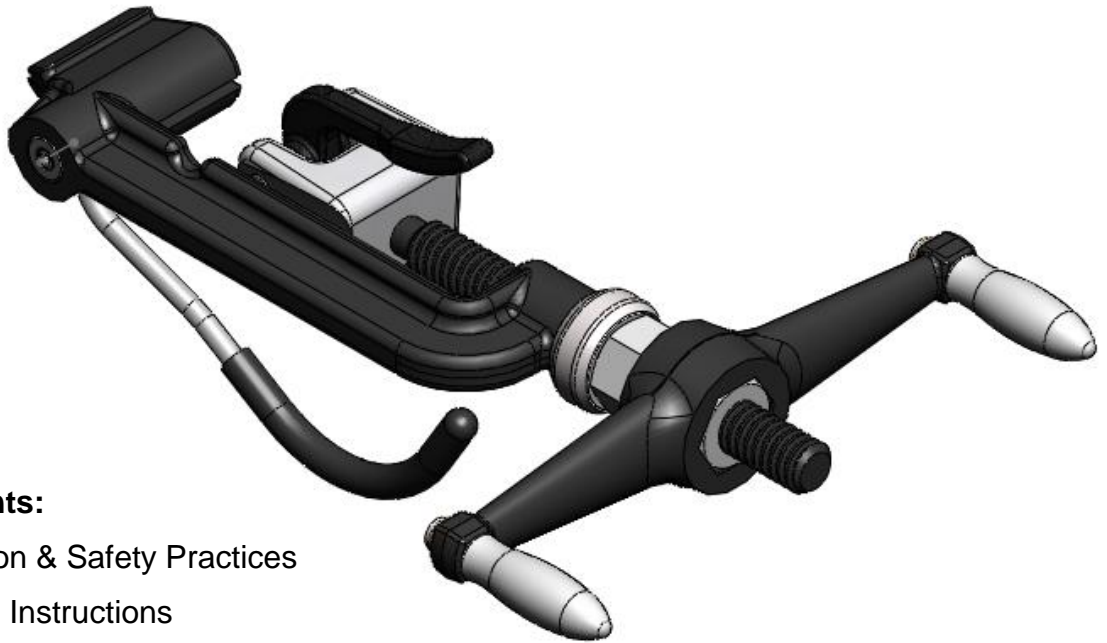

Table of Contents:

1. Introduction & Safety Practices
2. Operating Instructions
3. Tool Assembly Parts List
4. Cleaning & Warranty

Safety Practices:

1. Read this manual and become familiar with the tool before use.
2. Protective eyewear should be worn during use.
3. Wear appropriate gloves for handling steel.
4. When applying clamps, care should be taken to insure fingers are not in contact with the clamp during installation.
5. Never attempt to clamp objects which have the potential to burst, shatter or otherwise cause bodily harm.
6. Do not use tool on live electrical sources.

Operating Instructions



C00369 Heavy Duty Hand Tool

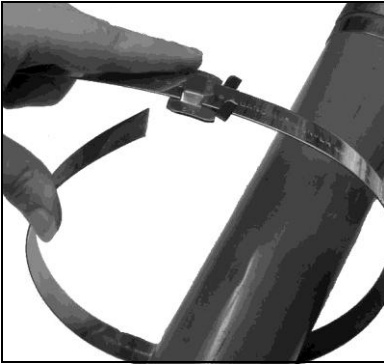

1. Slide buckle on band as shown. Bring tip of band around workpiece and again through buckle.

Note: Band may be used from bulk roll as this completely eliminates waste of band.



2. Insert band around workpiece again and through buckle. *Double wrapping develops much more radial compression than single wrapping.* Bend end of band under buckle.

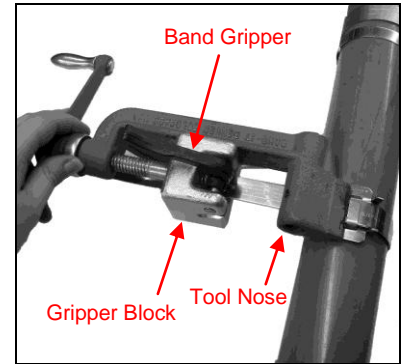

3. Place band in opening of tool nose and Gripper Block. Move into slot as far as possible, to avoid buckle sliding into Tool Nose. Tighten band clamp by turning the Tension Handle clockwise while holding Band Gripper tight against band. *NOTE: The spring load of the band gripper is not intended to secure and prevent the band from slipping during tension process.*



4. Place finger on BAND-IT Band at buckle bridge while tensioning. When you observe the band stops moving through the buckle, *maximum pressure is being exerted* around the workpiece. *Stop turning handle.*



5. *Roll tool over buckle, backing off with Tension Handle 1 - 1½ turns throughout entire rolling operation.* Failure to back off tension with tension handle throughout roll-over may result in breaking the band. There is no loss of tension as band released is used up in this process.

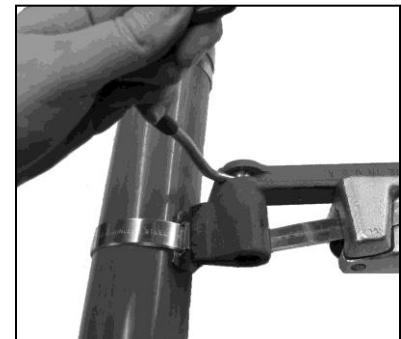

6. Rotate Cutting Handle forward to cut the band. When applying Giant Band clamps, prior to cutting off clamp, release Band Gripper and push Tool Nose away from buckle approx. ¼".

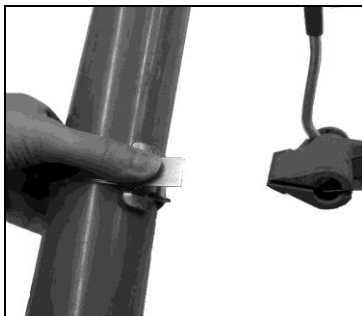

7. Remove tool, holding stub of band down.



8. Hammer down buckle ears to complete BAND-IT clamp.

Tool Assembly Parts List



C00369 Heavy Duty Hand Tool

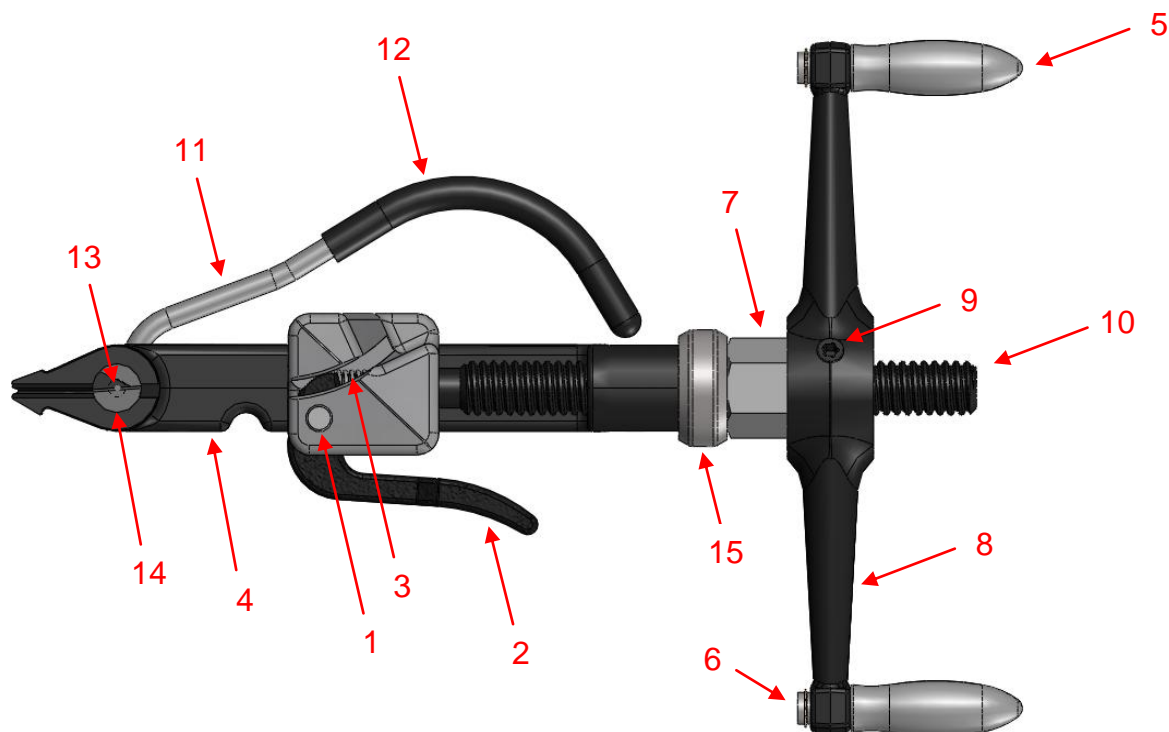

1. To assist in removing threaded parts, apply heat to soften locking compound.

2. When connecting item 13 (Set Screw) to item 14 (Cutter Bar), clean threads (male and female) of foreign matter, then apply one drop of medium strength locking compound (Loctite 242 or equiv.) onto male thread and connect parts together.

3. Kit # C01899 contains one each Band Gripper, one Gripper Spring and one Pin. Replace all parts as a set to maximize tool performance. Periodic cleaning of band gripper teeth will improve tool performance.

C00369 BAND-IT TOOL
REPAIR PARTS LIST

ASSY #	ITEM	DESCRIPTION	QTY
C01899	1	PIN, ECCENTRIC LEVER PIVOT	1
	2	BAND GRIPPER	1
	3	GRIPPER SPRING	1
C02187	4	TOOL FRAME	1
C04799	5	SPIN GRIP	2
	6	EXTERNAL RETAINING RING	2
	7	BUSHING, TENSION HANDLE	1
	8	TENSION HANDLE	1
C04986	9	SET SCREW, HALF DOG	1
C04986	10	TENSION SCREW, 5/8", LUBRICANT, FIN	1
C05887	11	CUTTER BAR HANDLE	1
	12	VINYL GRIP	1
	13	SET SCREW	1
	14	CUTTER BAR	1
C07086	15	THRUST BEARING	1

Gripper Cleaning Instructions:

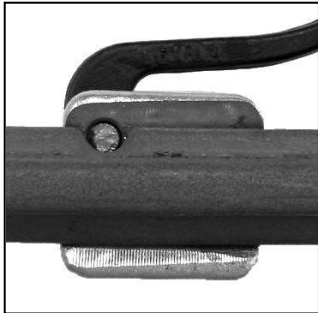

1. To remove Gripper, align Gripper Pin hole with notch in tool frame. Using a punch and hammer, punch Pin out of Slide Block.



2. Using a wire brush, clean all foreign matter from teeth.



3. To replace Pin, Gripper Spring must be seated in Tension Screw hole. Align Gripper hole with Slide Block hole and insert Pin using a hammer.

NOTE: Periodically apply food-grade white lubricant or equivalent to Tension Screw thread (item 10 on page 3) to prevent excessive wear.

If tool fails to securely grip tail of clamp, follow Gripper cleaning instructions above.

Refer to website for warranty information: <http://www.band-it-idex.com/warranty.html>



WWW.CABLEJOINTS.CO.UK
THORNE & DERRICK UK
TEL 0044 191 490 1547 FAX 0044 477 5371
TEL 0044 117 977 4647 FAX 0044 977 5582
WWW.THORNEANDDERRICK.CO.UK