

# Operating Instructions



WWW.CABLEJOINTS.CO.UK  
THORNE & DERRICK UK  
TEL 0044 191 490 1547 FAX 0044 477 5371  
TEL 0044 117 977 4647 FAX 0044 977 5582  
WWW.THORNEANDDERRICK.CO.UK

## C00269 JR. Hand Tool

### To Install a BAND-IT Junior Clamp:



Place BAND-IT tool in vise. Insert clamp in tool and grip end of band by Band Gripper Lever. **NOTE: The spring load of the band gripper is not intended to secure and prevent the band from slipping during the tension process.**

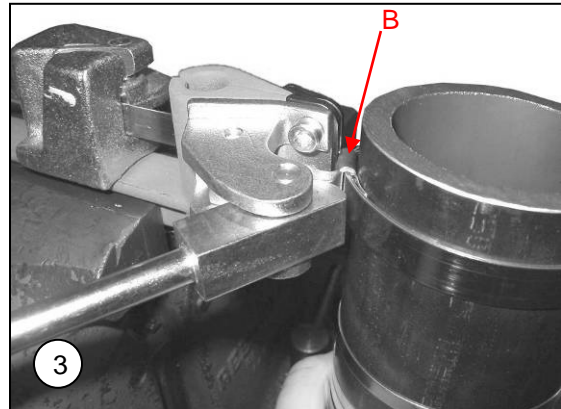

A. Roll hose over approximately 30°, BACKING OFF TENSION HANDLE ½ to 1 turn only through course of rollover, depending on type and size of hose.

B. Grip buckle with hook in nose by pushing cutter handle. Push cutter handle farther to cut the band completing BAND-IT JR. Clamp.



Insert hose in clamp. Take up clamp by turning the handle of BAND-IT TOOL clockwise while holding band gripper tight against band. To feel movement of band, place finger on BAND-IT BAND at buckle edge (shown by arrow) while tensioning with tool handle. When you no longer feel band moving through buckle, MAXIMUM PRESSURE HAS BEEN EXERTED BY BAND-IT BAND.

**NOTE: USE OF VISE IS OPTIONAL FOR BAND WIDTHS OF ½" OR LESS. WE STRONGLY SUGGEST SECURING THE TOOL IN A VISE FOR CLAMPS WIDER THAN ½".**

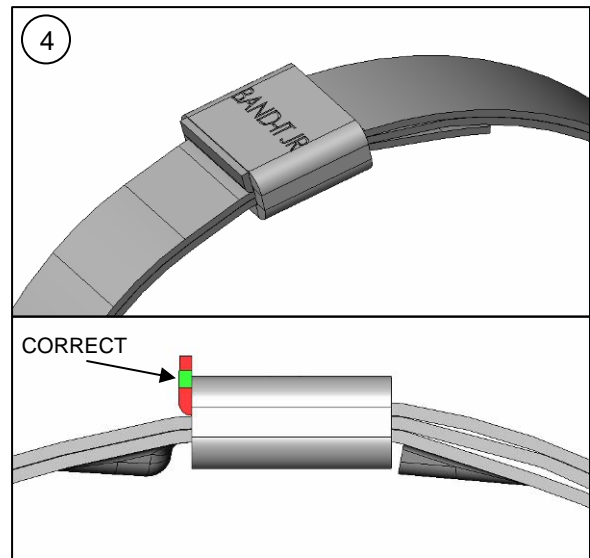

The finished BAND-IT JR. Smooth I.D. Clamp. Lip lock will be bent upward 90° and have a cut-off edge (shown in green) that is flush to the edge of the buckle. Edges shown in red are too high or too low and may result in lower lock strength or sharp edges.

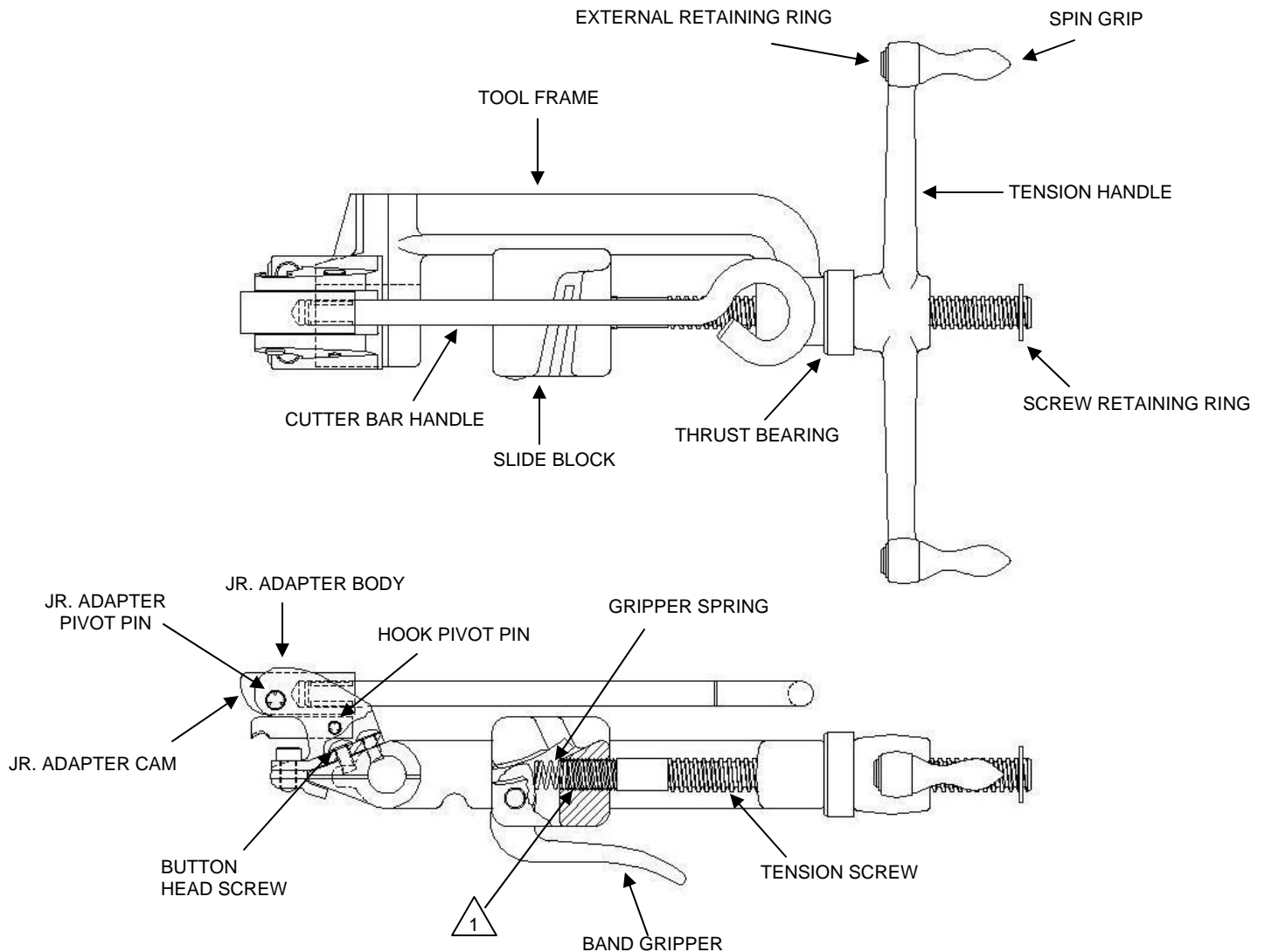

**NOTES:**

1. To assist in removing threaded parts, apply heat (softens locking compound).
2. When connecting the tension screw to the slide block, or button head screws to the JR. adapter body, clean threads (male and female) of foreign matter, then apply two drops of medium strength locking compound (Loctite 242 or equiv.) onto male threads and connect parts together.
3. Before using BAND-IT JR. tool check to see that the cutter blade and backing plate are fully tightened. Loose screws can cause breakage of cutter blade or backing plate. Use hex key provided with tool to tighten screws if needed.
4. Assemble tension handle, then attach retaining ring to tension screw in location shown. Place ring on groove, then push ring against a hard surface such as a table until it snaps securely in place.
5. Kit # C01899 contains one each of a C01887 band gripper, C03186 gripper spring and C01787 pin. Replace all parts as a set to maximize tool performance. Periodic cleaning of band gripper teeth will improve tool performance.

REPAIR PARTS LIST FOR C00269	
PART #	DESCRIPTION
C02240	TOOL FRAME
C01687	THRUST BEARING
C01387	SLIDE BLOCK
C00689	TENSION HANDLE AND SCREW KIT INCLUDES: SPIN GRIP, EXTERNAL RETAINING RING, SCREW RETAINING RING, AND TENSION HANDLE
C01899	GRIPPER ASSEMBLY KIT INCLUDES: GRIPPER, PIN, AND GRIPPER SPRING
J01499	HANDLE ASSEMBLY, JR. ADAPTER INCLUDES: JR. ADAPTER CAM AND HANDLE
J02299	BODY KIT, JR. ADAPTER INCLUDES: JR. ADAPTER BODY AND CAM PIVOT PIN
J93099*	CUTTER BLADE KIT INCLUDES: CUTTER BLADE, BACKING PLATE, SCREWS AND HEX KEY
J00587	SHEAR HOOK
J00987	HOOK PIVOT PIN
S48087	SCREW, BUTTON HD. #10-32 X 3/8 L

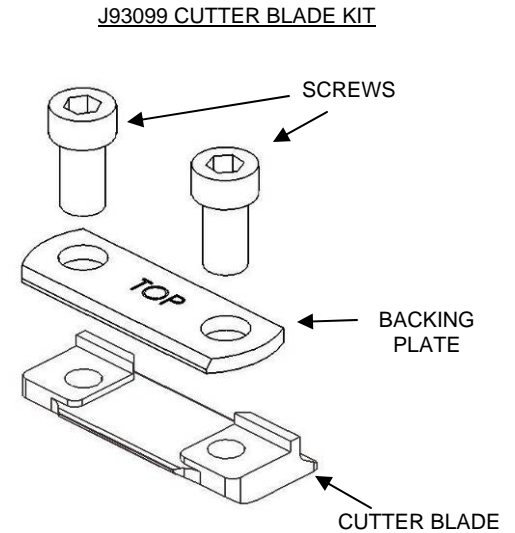

\*NOTE: Replacement cutter blade kit design may vary. Replace all parts as a kit.

Refer to website for warranty information: <http://www.band-it-idex.com/warranty.html>



WWW.CABLEJOINTS.CO.UK  
**THORNE & DERRICK UK**  
 TEL 0044 191 490 1547 FAX 0044 477 5371  
 TEL 0044 117 977 4647 FAX 0044 977 5582  
 WWW.THORNEANDDERRICK.CO.UK