



**BAND-IT**<sup>®</sup>  
THE CLAMPING EXPERTS

# Repair Parts List

## A94079 Ultra-Lok Tool



WWW.CABLEJOINTS.CO.UK  
**THORNE & DERRICK UK**  
 TEL 0044 191 490 1547 FAX 0044 477 5371  
 TEL 0044 117 977 4647 FAX 0044 977 5582  
 WWW.THORNEANDDERRICK.CO.UK

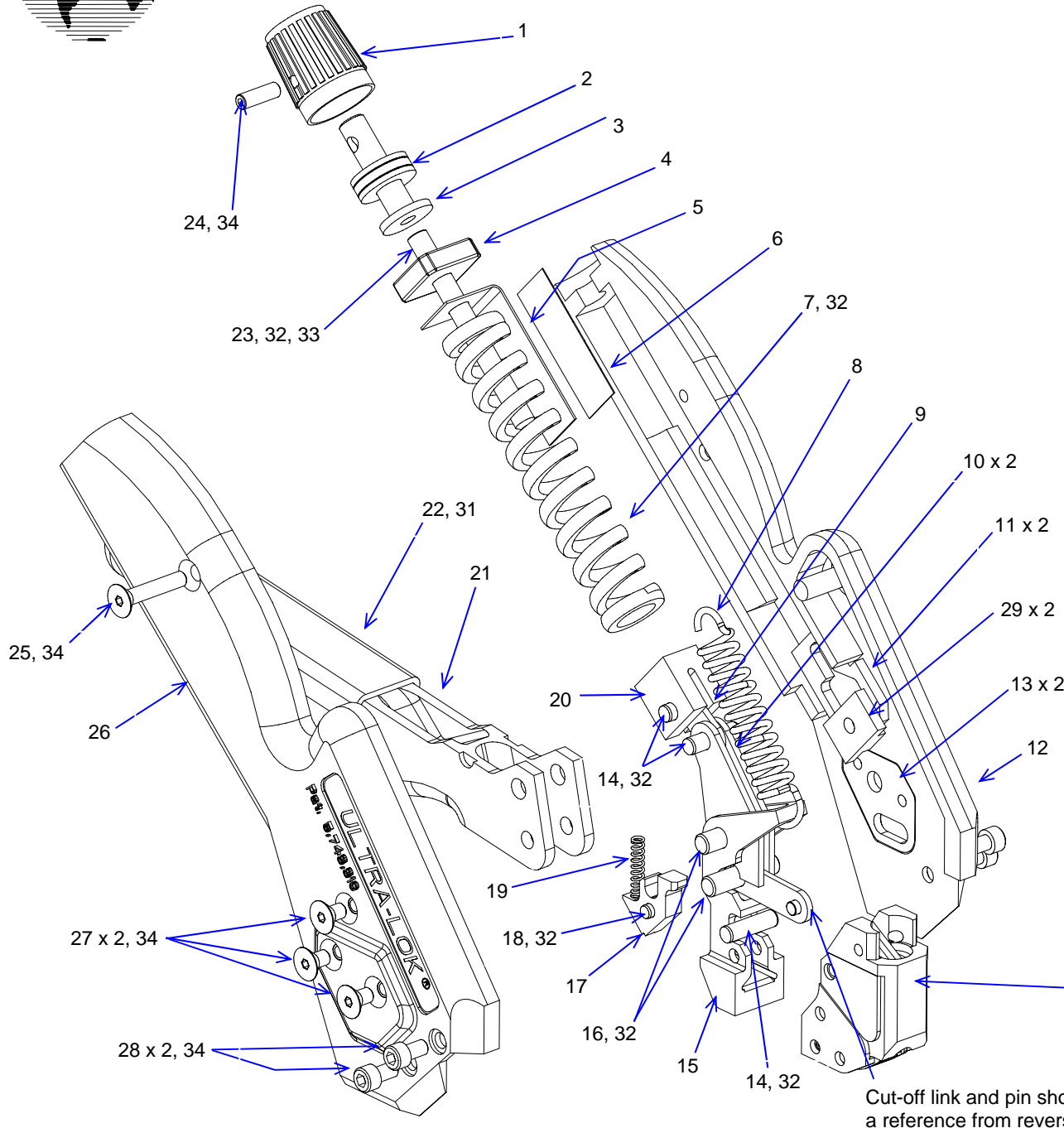

Item	Band-It #	Qty	Description
1	M53387	1	Knob, adjustment
2	M53287	1	Bearing, thrust (3 pieces)
3	A92577	1	Cap, tension
4	A93487	1	Block, tension
5	A93587	1	Indicator, tension
6	A92387	1	Decal, tension indicator
7	K02187	1	Spring, die
8	A91787	1	Spring, extension
9	A95487	1	Link, tension
10	A92267	2	Arm, tension
11	A95387	2	Plate, tension
12	K93487	1	Body, left, black
13	A91477	2	Plate, body
14	A73587	3	Pin, dowel, 5/32 x 9/16 lg
15	A91387	1	Lever, pull-up, front load
16	A94887	2	Pin, straight, 3/16 x .780 lg
17	A91187	1	Gripper, pull
18	K97487	1	Pin, .125 x .313 lg
19	A93887	1	Spring, 1/8 x 5/8, 25#
20	A92487	1	Plunger, tension
21	K97587	1	Handle
22	M50487	1	Grip, textured, green
23	A94487	1	Screw, set, #10-24 x 2.00 lg
24	A85687	1	Screw, set, #6-32 x 7/16 lg
25	A96087	1	Screw, flt-hd, #6-32 x 3/4 lg
26	K93587	1	Body, right, black
27	A91987	6	Screw, flt-hd, #6-32 x 1/4 lg
28	M54587	4	Screw, cap, #6-32 x 1/4 lg
29	K57887	2	Pad, centering
30			
31	-	-	Adhesive, cyanoacrylate
32	-	-	Grease, extreme pressure
33	-	-	Red Loctite (high strength)
34	-	-	Blue Loctite (med. Strength)

See list of tool head parts on reverse side

Cut-off link and pin shown as a reference from reverse side



**BAND-IT**<sup>®</sup>  
THE CLAMPING EXPERTS

# Repair Parts List A94079 Ultra-Lok Tool

Partial view of pull-up lever and spring shown as a reference from previous page

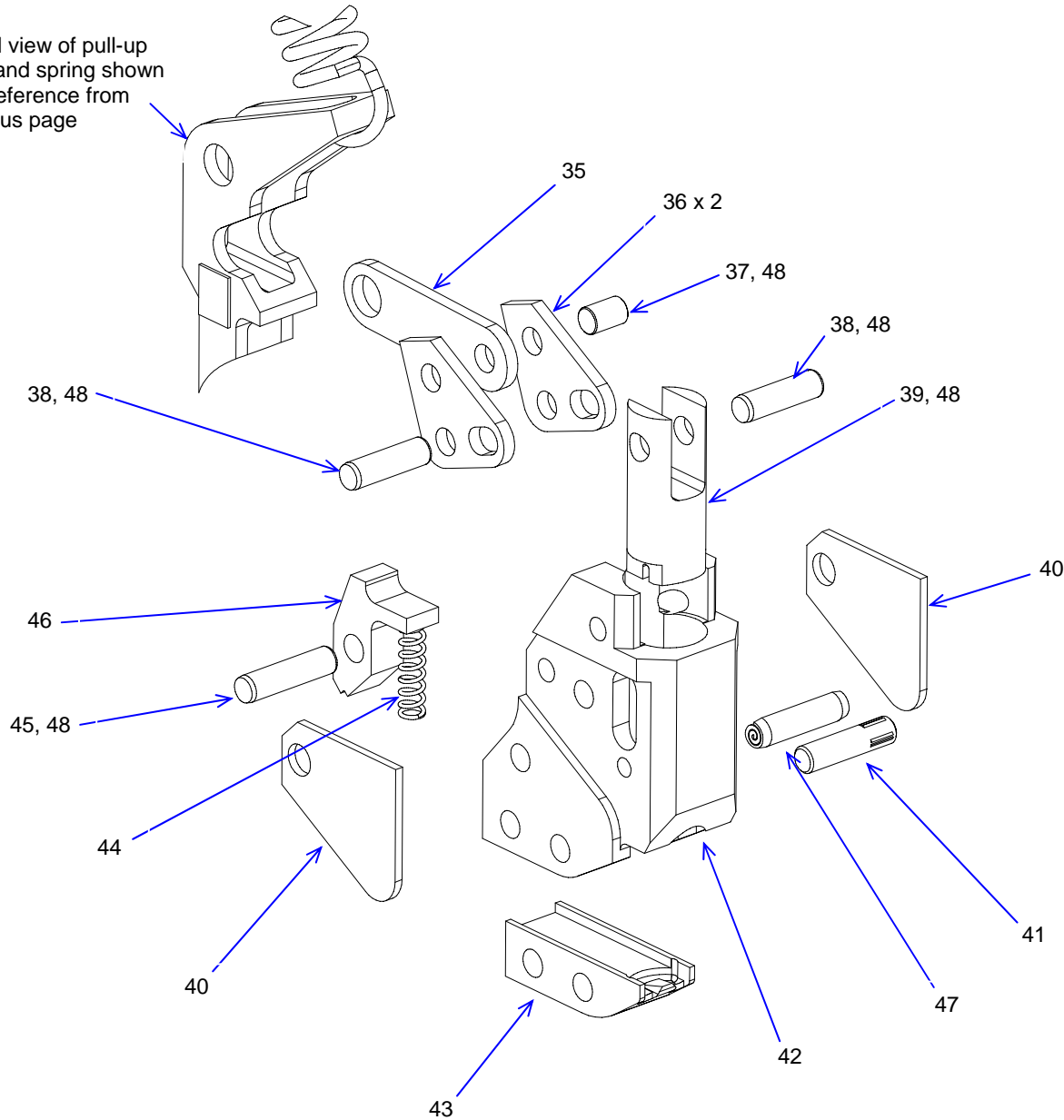

Item	Band-It #	Qty	Description
35	A92177	1	Link, cut-off
36	A94987	2	Lever, cut-off
37	A94687	1	Pin, straight, 1/8 x 3/16 lg
38	M01887	2	Pin, dowel, 1/8 x 7/16 lg
39	A92987	1	Knife, Ultra-Lok
40	A94187	2	Cover, head
41	A93977	1	Pin, Groove, 1/8 x 9/16 lg
42	A92677	1	Tool head
43	A92787	1	Blade, Ultra-Lok
44	C09587	1	Spring, 1/8 x 1/2, 13#
45	A84487	1	Pin, dowel, 1/8 x 1/2 lg
46	A91287	1	Gripper, hold
47	A90987	1	Pin, spiral, 1/8 x 1/2 lg
48	-	-	Grease, extreme pressure



**Warning:**

Always wear safety glasses when operating hand tool.

**Instructions:**

1. Turn tension adjustment knob until desired tension setting is displayed in tension indicator window. Space between numbers counts as one-half setting. See step 6.
2. Extend handle open to release gripping mechanism and insert clamp tail into tool through front load entry.
3. Squeeze handle repeatedly to tighten band around object. Be sure to release handle completely to use full pull-up stroke of tool. Buckle must be secure against the tool head. Once the preset tension has been reached, the handle will no longer release completely.
4. To cut-off excess clamp tail, squeeze handle one last time. Once the band is cut, the handle must be released to separate the tool from the clamp.
5. The tool must be reset by extending the handle out until it snaps into place. The tool will be ready to apply the next clamp.
6. Tension Setting Range:

.250 Smooth I.D. Ultra-Lok	0 – 8
.250 Smooth I.D. Tie-Lok	0 – 8
.250 Smooth I.D. Jr. single-wrap	0 – 8
.250 BAND-IT Band and A201 Buckle	0 – 8

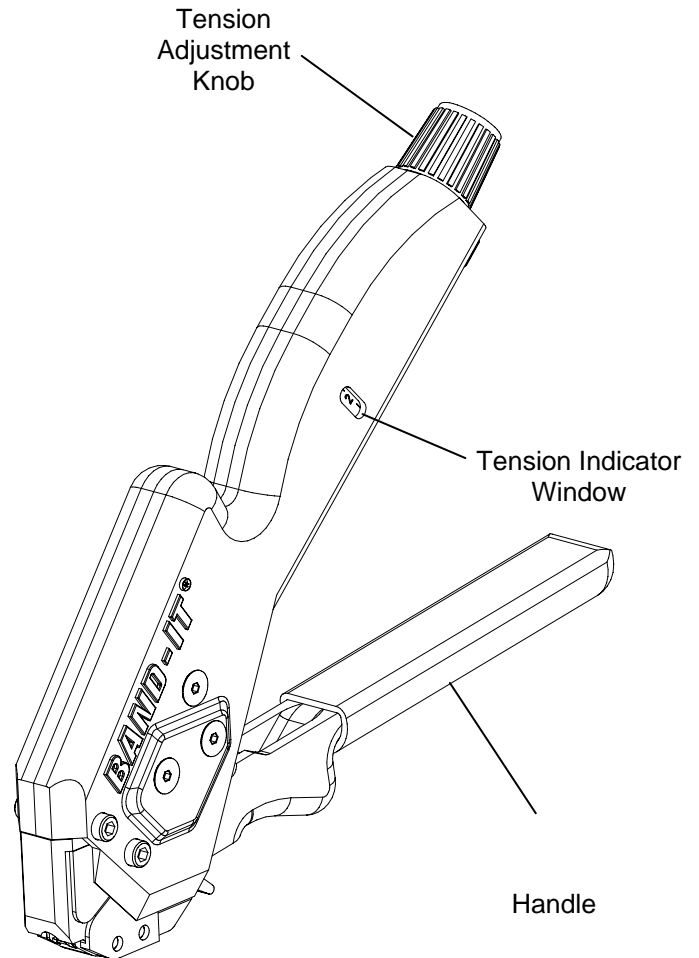



**BAND-IT**<sup>®</sup>  
THE CLAMPING EXPERTS

## Operating Instructions A94079 Ultra-Lok Tool Roll Band Application

- A. Turn adjustment knob until tension indicator is set to -0-.
- B. While holding handle all the way out from tool body, insert desired length of roll band into rear of tool head.
- C. Pull handle towards tool body until band is cut. Hold handle away from tool body. Pull band out from front of tool head.
- D. If making more than one clamp, repeat the above steps.

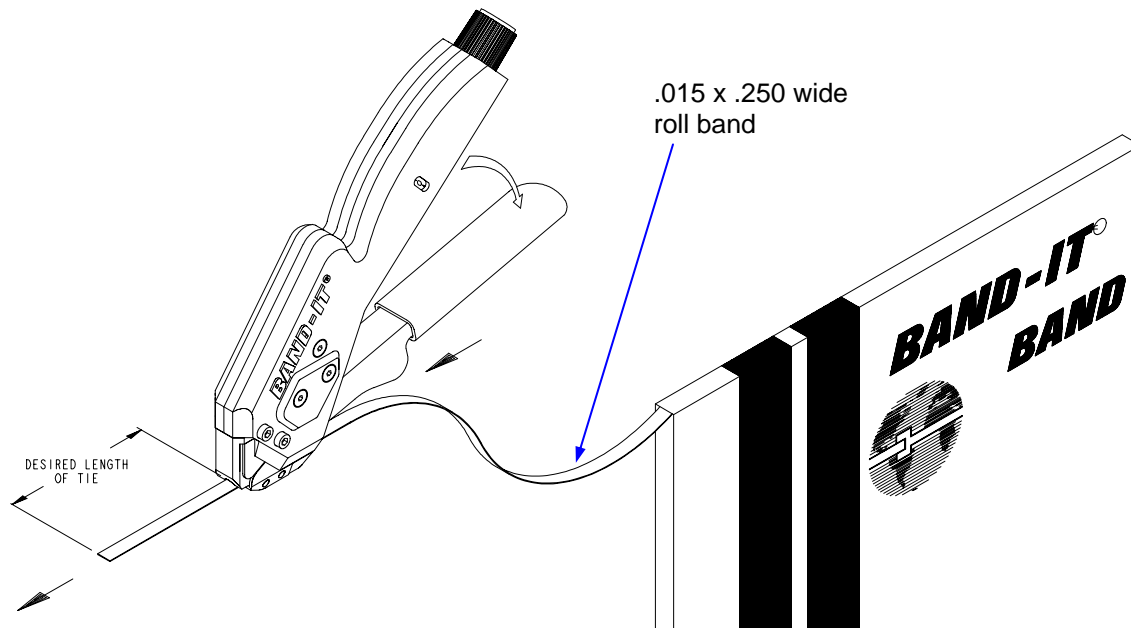

- E. Remove band from rear of tool head.
- F. Slide buckle onto band until it is up against the buckle stop formed by the tool. "BAND-IT" logo should be opposite the protrusion on the buckle stop.
- G. Slide other end of band through buckle to form a clamp.

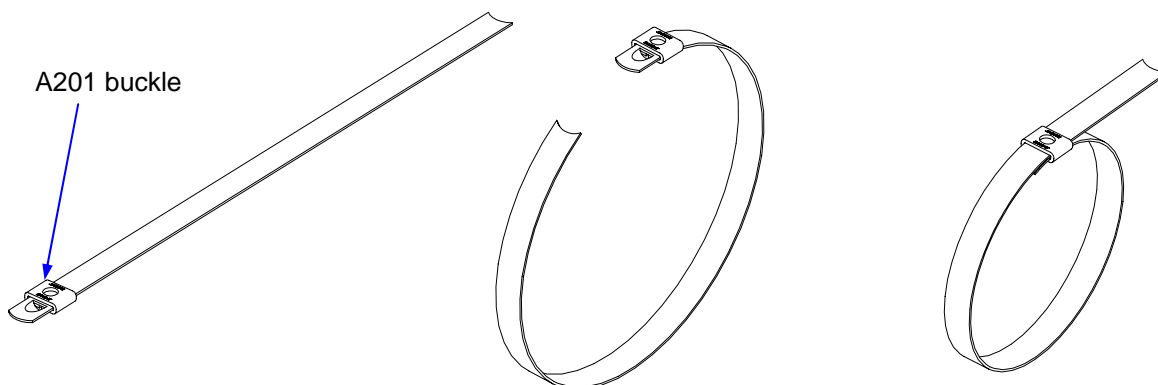

- H. Repeat steps 1 through 7 on the previous pages of this instruction sheet.
- I. To make another clamp after already clamping an object, do not force handle open, instead, position roll band behind the tool head and slowly move handle away from tool body until band passes through to desired length. Pull handle towards tool body until band is cut. Repeat E, F, G, H.

Note: if handle "snaps" out during step I, you must start over with step A.