

Indoor Voltage Transformer Fuses, WBP Outdoor Voltage Transformer Fuses, BRT

Catalogue 1YMB612070-en



1. FEATURES

- Unlimited breaking capacity
- Short-circuit current limiting
- Small dimensions.

2. APPLICATIONS

The WBP fuse-links are used to protect switchgear equipment against short-circuits in voltage transformers. Protection of switchgear equipment is very effective thanks to unlimited breaking capacity and short circuit current limitation. Thanks to very small dimensions WBP type fuse-links can be used in various types of switchgears, including flame-proof types.

3. ENVIRONMENTAL OPERATING CONDITIONS

The Type WBP... and BRT... Fuse-links can be operated under the following environmental conditions:
Table 1.

Temperature	Type of fuse-links			
	WBP		BRT	
	N3	T3	N1	T1
From -5°C to +40°C	From -5°C to +50°C	From -25°C to +40°C	From -10°C to +50°C	
Relative humidity of ambient air at a temperature: N - +20°C T - +30°C	to 80%	to 95%	to 100%	to 100%
Height of installation above the sea level	Up to 1000 m			

Designations:

- N - Normal climate
- T - Tropical wet and dry climate
- 1 - Outdoor installation
- 3 - Indoor installation

4. DESIGNATIONS AND VERSIONS

4.1 WBP indoor instrument transformer fuse-links numbering system

The numbering system for the WBP fuse-links has two alphanumeric sections as shown in the following diagram.



Indoor Fuse-link type	Rated Voltage
	6 - 7,2 kV
	10 - 12 kV
	20 - 24 kV
	30 - 36 kV

4.2 BRT outdoor instrument transformer fuse-links numbering system

The numbering system for the BRT fuse-links has two alphanumeric sections as shown in the following diagram.

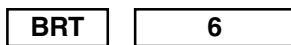

Outdoor Fuse-link type	Rated voltage
	6 - 7,2 and 12 kV
	15 - 17,5 and 24 kV
	30 - 36 kV

4.3 Indoor fuse-bases numbering system

The numbering system for indoor fuse-bases has two alphanumeric sections as shown in the following diagram.

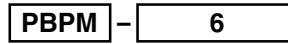

Fuse-base type	Rated voltage
	6 - 7,2 kV
	10 - 12 kV
	20 - 24 kV
	30 - 36 kV

4.4 Outdoor fuse-bases numbering system



Fuse-base type	Kind of fuse base	Rated voltage	Additional designation
		36 kV	
	I - hanging type		
	III - standing type		

The numbering system for outdoor fuse-bases have four double alphanumeric sections as shown in the following diagram.

A fuse-link when mounted on a fuse-base makes a complete fuse. For the available fuse-bases refer to Table 2.

5. CONSTRUCTION AND OPERATION

5.1 Construction and operation of fuse-links

A fuse-link consists of an insulation tube¹⁾ whose both ends are terminated with end caps. Fuse elements are made from specially profiled silver wire. The fuse elements are helically wound on the porcelain stick. The resistance of the fuse-links is acc. to table 2. The fuse interior is tightly filled with arc-quenching material, whose chemical composition and granularity have been appropriately chosen. The fuse-link is sealed at its both ends.

The fuse operation depends on automatic single-time interruption of fault current in the protected circuit by melting of its fuse element and quenching of the electric arc produced in the fuse-link interior. The fuse-links limit the peak value of short-circuit currents and hence effectively protect circuits from thermal and electromagnetic effects of short-circuits.

A fuse-link when mounted on its fuse-base makes a complete fuse. For the available-base refer to Table 2. Voltage transformers fuse links can be used as build-up version and in special bases with one contact installed on the voltage transformer and one on the post insulator.

5.2 Construction of the fuse-bases

The fuse-base consists of a steel beam fitted with protective-earthing terminal. There are two indoor or outdoor support insulators on the beam. Contacts are mounted on the upper side of insulator. The set of contacts consists of contact spring, compression spring, and terminals.

7. COMPLIANCE WITH STANDARDS

7.1 The fuse-links meet the requirements of the following standards:

- Polish Standard PN-77/E-06110
- British Standard BS:2692:1956
- Russian Standard GOST 2213; 1959

7.2 The fuse-bases meet the requirements of the following standards:

- Polish Standard PN-77/E-06110
- German Standard VDE 0670 Teil 4/3 1967
- International Standard IEC 282-1 of 1985

8. HOW TO ORDER

Order by specifying the product name, type symbol, rated value, rated current and quantity.

All additional demands which are not listed in this Catalogue should be agreed with the manufacturer by means of an Inquiry where the sources of requirements (regulations, standards, etc.) are to be specified.

6.1 Order example

1. Type WBP-6 fuse-link for a rated voltage of 7.2 kV and rated current of 0,7 A - 10 pcs
2. Type PBPM-6 Indoor fuse-base for a rated voltage of 7,2 kV - 20 pcs

¹⁾ Insulating tube is made from glass (WBP) or porcelain (BRT)

6. SPECIFICATIONS

6.1 Technical data of fuse-links

Table 2

Fuse-link Type	Rated Voltage	Frequency	Rated current	Rated Breaking Current	Rated Breaking Capacity	Overvoltages	Weight	Resistance		Fuse-base Type
	U _n							Min.	Max.	
	kV	Hz	A	kA	MVA	kV	Kg	Ω	Ω	
WBP-6	7,2	50 or 60	0,7	120	>1500	<23	0,12	42	52	PBPM-6
WBP-10	12		0,6	72		<38	0,16	62	72	PBPM-10
WBP-20	24		0,5	36		<75	0,20	135	165	PBPM-20
WBP-30	36		0,4	24		<112	0,25	225	275	PBPM-30
BRT-6	7.2 and 12	50 or 60	0,8	80 ²	>1000	<23	1,8	57	63	-
BRT-15	17.5 and 24			33 ³		<55	2,2	144	156	PBPN-24-1
BRT-30	36			16		<112	2,6	290	310	PBWMNI 36 w.II-1 PBWMNIII 36 w.II-1

The resistance are to be measured by an electrical bridge method or technical method using measuring instrument with accuracy class not worse than 0.5% at an ambient temperature of $t = 20^{\circ}\text{C} \pm 2^{\circ}\text{C}$.

²⁾ for U_n = 12 kV I_{ws} = 48 kA

³⁾ for U_n = 24 kV I_{ws} = 24 kA

Note: Due to the introduction of improvements, the right is reserved to modify the products.

Note: In case of installation of WBP fuses in closed housing and similar equipment characterised by heat exchange (stabilised ambient air temperature exceeds +40°C) the value of nominal current I_n should be reduced by 0.1 A.

6.2 Technical data of fuse-bases

Table 3

Type of fuse-base	Rated voltage	Frequency	Impulse withstand voltage of insulation		50 Hz withstand voltage of insulation		Type of fuse-link
	U _n		to earth	in pole	to earth	in pole	
	kV	Hz	kV	kV	kV	kV	
PBPM-6	7.2	50 or 60	60	70	27	35	WBP-6
PBPM-10	12		75	85	35	45	WBP-10
PBPM-20	24		125	145	55	75	WPB-20
PBPM-30	36		170	200	75	100	WBP-30
PBPN-24-1	24		125	145	55	75	BRT-15
PBWMNI 36 w.II-1	36		170	195	70	85	BRT-30
PBWMNIII 36 w.II-1	36		170	195	70	80	

PBPM – an indoor fuse-base with resin insulators

PBPN – an outdoor suspended fuse-base on 24 kV

PBWMNI 36 w.II-1 – an outdoor suspended fuse-base on 36 kV

PBWMNIII 36 w.II-1 – an outdoor fuse-base on 36 kV

Note: Due to the introduction of improvements, the right is reserved to modify the products.

Recommendation of fuse links selection for MV voltage transformer protection

ABB Sp. z o.o. recommends using instrument transformers fuse elements type WBT from our production portfolio as protection for ABB's voltage transformers types UMZ and UDZ equipped with fuse holder. Using instrument transformer fuses has two main functions; to protect distribution equipment against results of internal voltage transformers short circuits and to reduce probability of explosion possibility in case of damage of internal isolation of voltage transformers.

The selection of fuse element for protection of voltage transformer should be done mainly in dependence on rated primary voltage of voltage transformer*. The rated voltage of fuse element should be equal or higher of (phase to phase) rated voltage for primary winding of voltage transformer, for example for VT type UMZ 15-1 working with voltage $\sqrt{3}$ kV on primary winding, one should select fuse link type WBP-10 that rated voltage is 10 kV.

The rated current of fuse links type WBP was reduced from 0,8A to 0,4-0,7A (depending on U_n) starting from January 2001. The reason of this change was to improve cooperation between fuse link and voltage transformers.

Comparison of past voltage transformer fuse links type WBP with the new one is presented in the table below:

ABB Sp. z o.o. recommends to use new fuse links with limited rated current (0,4-0,7A) for protection voltage transformers type UMZ and UDZ instead of using former ones with rated current 0,8A.

Fuse link type	Rated voltage U _n	Rated continuous (till 12.2000) I _n	Current continuous current (from 01.2001) I _n
	kV	A	A
WBP-6	7.2	0.8	0.7
WBP-10	12		0.6
WBP-20	24		0.5
WBP-30	36		0.4

* In rarely cases when the following criteria have been fulfilled:

- instrument transformer is used with rated primary voltage below 3000 V;
 - power taken from instrument transformer is much higher then rated power output and it is close to the limit of thermal power output;
- the user should contact producer (ABB sp. z o.o.) to be individually advised regarding proper selection of voltage transformer protection.

DIMENSIONAL DRAWINGS

Dimensional drawing of WBP type fuse-links

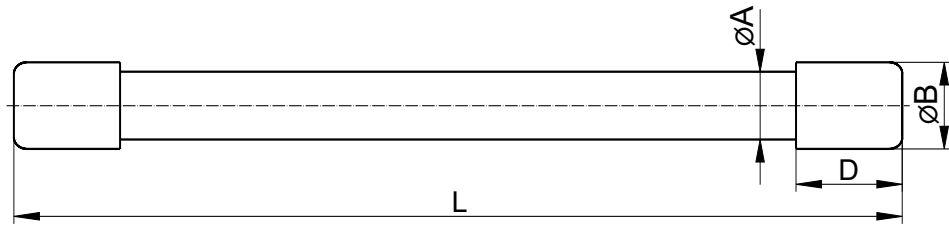

Notes:

Connections: silver-plated cooper.

Deviations of dimensions with no tolerance specified shall be within $\pm 3\%$.

Fuse-link type	Dimensions (mm)			
	L	D	$\varnothing A$	$\varnothing B$
WBP-30	385 \pm 3	25	18	23
WBP-20	310 \pm 3	25	18	23
WBP-10	250 \pm 3	25	18	23
WBP-6	210 \pm 3	25	18	23

B15/04.00 – Dimensional drawing of BRT type fuse-links

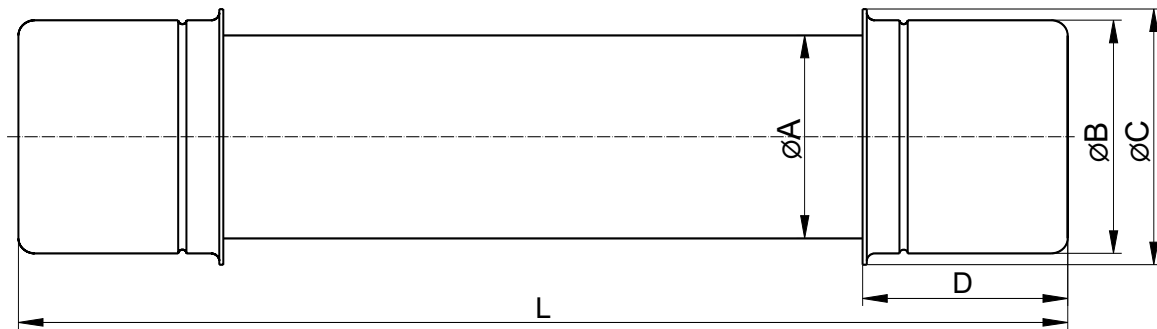

Notes:

Connections: silver-plated cooper.

Deviations of dimensions with no tolerance specified shall be within $\pm 3\%$.

Fuse-link type	Dimensions (mm)				
	L	D	$\varnothing A$	$\varnothing B$	$\varnothing C$
BRT-30	469 \pm 1,5	50	54	62	68
BRT-15	393 \pm 1,5	50	54	62	68
BRT-6	311 \pm 1,5	50	54	62	68

Dimensional drawing of PBPM-6 and PBPM-10 type fuse-bases

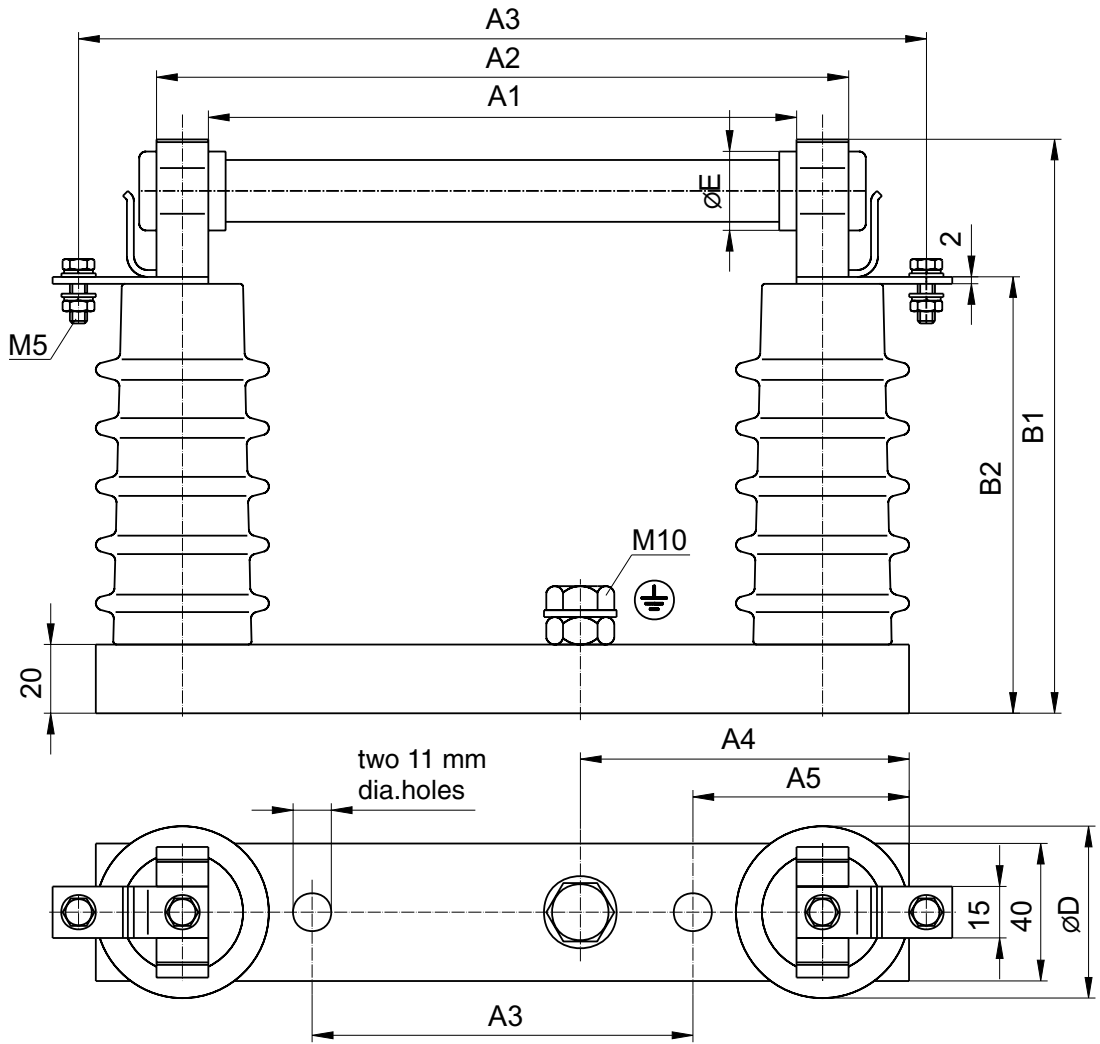

Notes:

Earthing Terminal; tinned steel.

Connections: silver-plated brass

Contact Springs: silver-plated brass

Deviations of dimensions with no tolerance specified shall be within $\pm 3\%$.

Fuse base type	Dimensions (mm)									
	A1	A2	A3	A4	A5	A6	B1	B2	$\varnothing D$	E
PBPM-6	170 \pm 2	200 \pm 2	245	110	95	62,5	165	128	50	23
PBPM-10	210 \pm 2	240 \pm 2	285	150	95	62,5	190	153	50	23

Dimensional drawing of PBPM-20 and PBPM-20 type fuse-bases

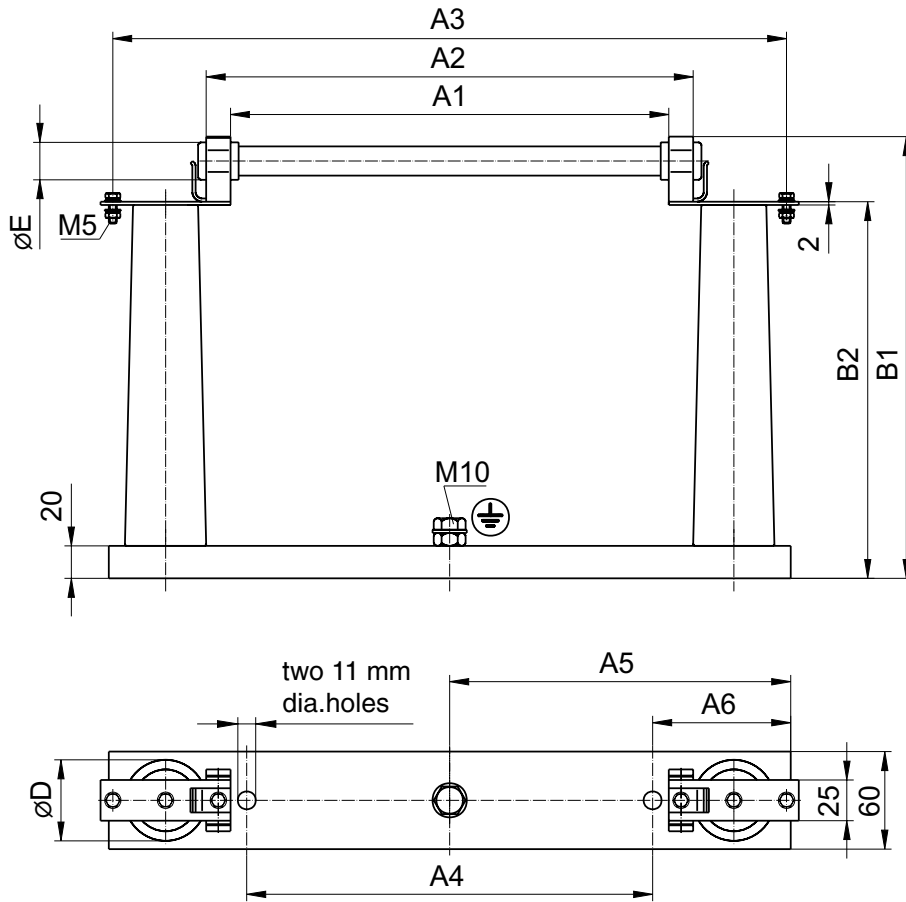

Notes:

Earthing Terminal; tinned steel.

Connections: silver-plated brass

Contact Springs: silver-plated brass

Deviations of dimensions with no tolerance specified shall be within $\pm 3\%$.

Fuse base type	Dimensions (mm)									
	A1	A2	A3	A4	A5	A6	B1	B2	ØD	E
PBPM-20	270±2	300±2	415	250	210	85	272	232	50	23
PBPM-30	345±2	375±2	490	325	247,5	85	362	322	70	23

Dimensional drawing of PBPN-24-1 and PBWMNI 36 w.II-1 type fuse-bases

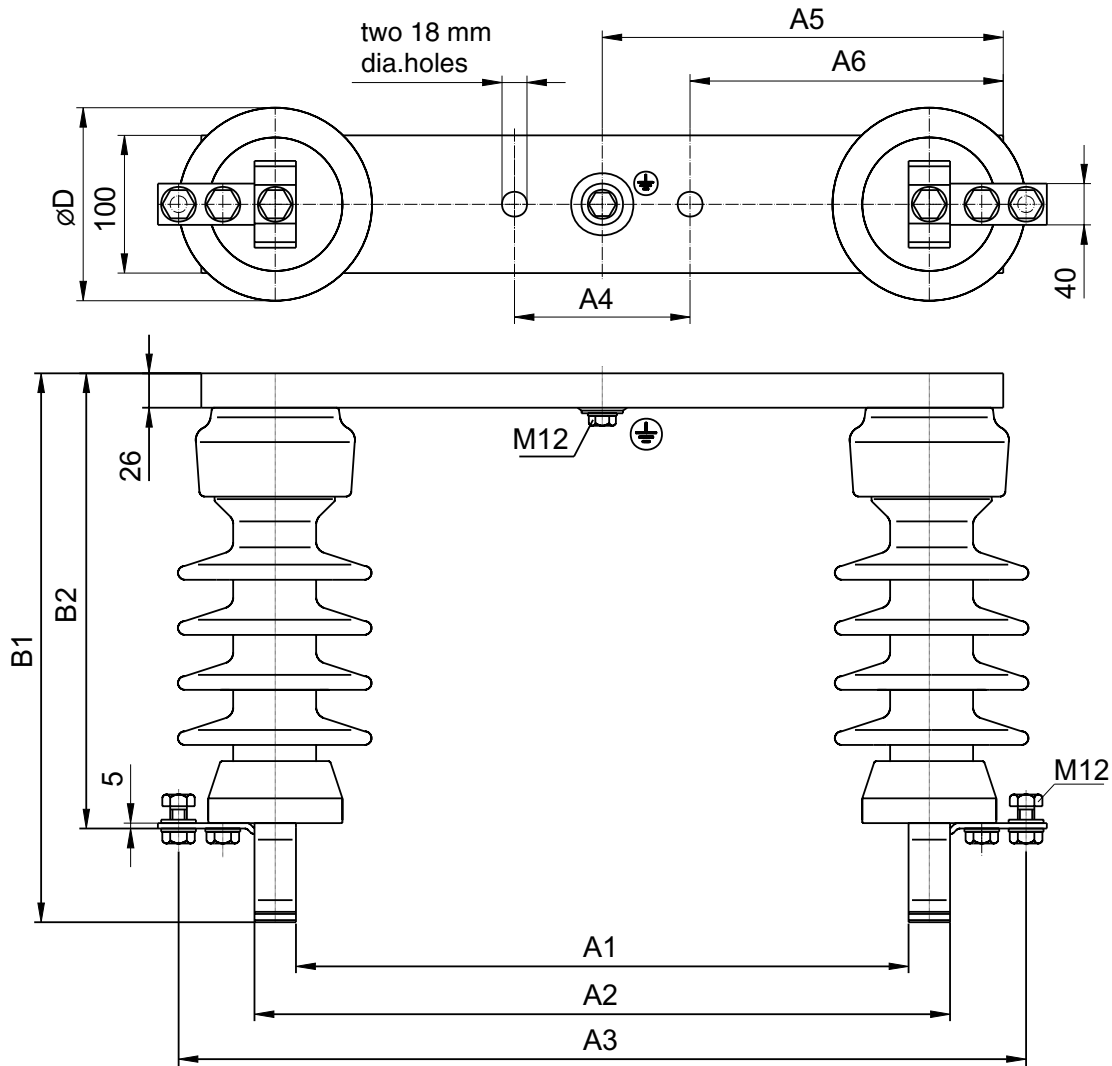

Notes:

Earthing Terminal; tinned steel.

Connections: silver-plated brass

Contact Springs: silver-plated brass

Deviations of dimensions with no tolerance specified shall be within $\pm 3\%$.

Fuse base type	Dimensions (mm)									
	A1	A2	A3	A4	A5	A6	B1	B2	øD	E
PBPN-24-1	297±2	357±2	647	127	223	159,5	417	336	145	62
PBWMNI 36 w.II-1	462±2	552±2	632	205	265	159,5	559	476	175	62

Dimensional drawing of PBWMNIII 36 w.II-1 type fuse-bases

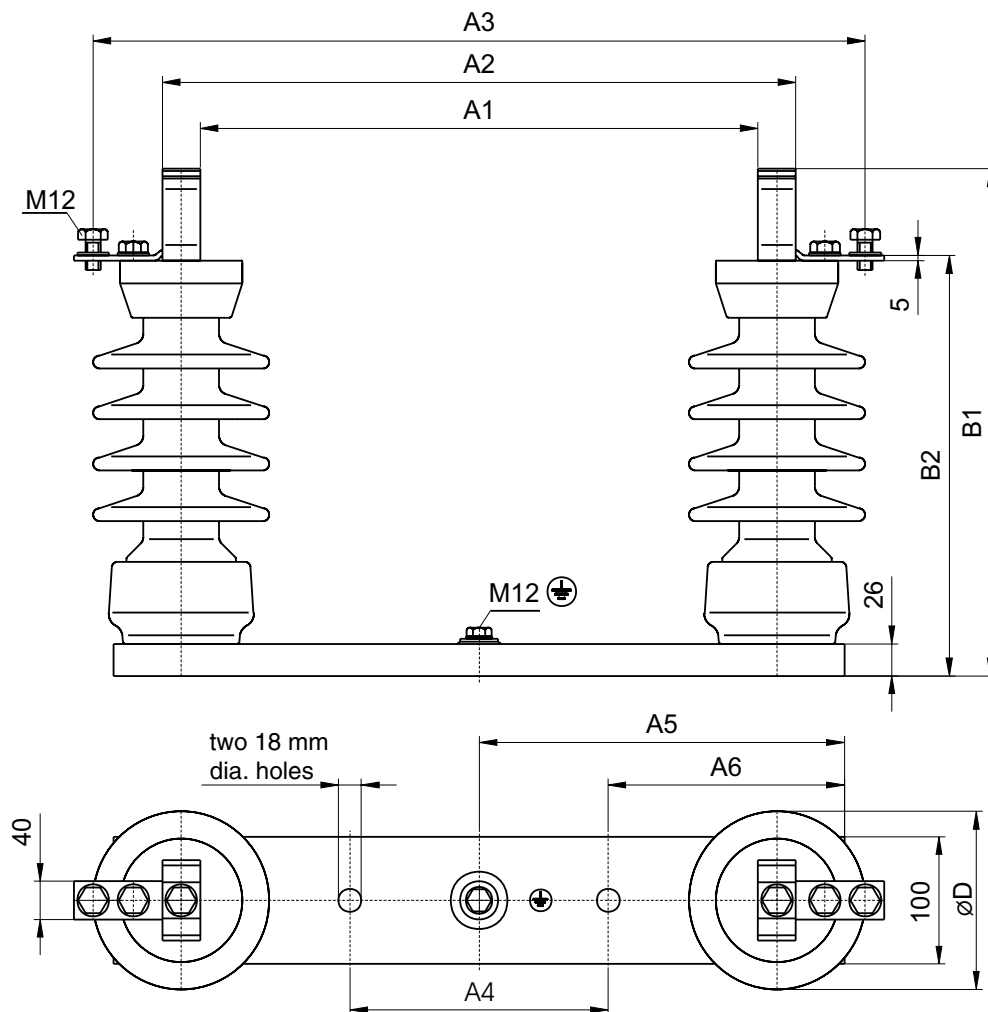

Notes:

Earthing Terminal; tinned steel.

Connections: silver-plated brass

Contact Springs: silver-plated brass

Deviations of dimensions with no tolerance specified shall be within $\pm 3\%$.

Fuse base type	Dimensions (mm)									
	A1	A2	A3	A4	A5	A6	B1	B2	$\varnothing D$	E
PBWMNIII 36 w.II-1	462 \pm 2	552 \pm 2	632	205	265	159,5	559	476	175	62

ABB is working to continuous improve the products. Therefore we reserve the right to change design, dimension and data without prior notice.



ABB Sp. z o.o.

Power Technologies Division

ul. Leszno 59

06-300 Przasnysz, Poland

Phone: (+48 22) 51 52 831, 51 52 653

Fax: +48 22 51 52 659

e-mail: export.plzwa@pl.abb.com

www.abb.com