

eltherm®



www.heattracing.co.uk
Thorne and Derrick UK
Tel 0044 191 490 1547 Fax 0044 191 477 5371
Tel 0044 117 977 4647 Fax 0044 117 9775582
www.thorneandderrick.co.uk

Table of contents

| | |
|--|------|
| Introduction | 1.02 |
| Type ELP/SI, -/FEP, -/PFA <i>Parallel heating cable</i> up to 260 °C | 1.03 |
| Type ELKM-A, -AS, -AE <i>Heating cable</i> up to 260 °C | 1.05 |
| Type ELKM-AG-L <i>Heating cable</i> up to 260 °C | 1.07 |
| Type ELKM-AG-N <i>Heating cable</i> up to 260 °C | 1.09 |
| Type ELK-A, -AS, -AE <i>Heating cable</i> up to 260 °C | 1.13 |
| Type ELK-AG <i>Heating cable</i> up to 260 °C | 1.15 |
| Type ELW-GN <i>Heating tape</i> up to 260 °C | 1.17 |
| Type ELW-VA <i>Heating tape</i> up to 260 °C | 1.19 |
| Type ELK-H <i>Heating cable</i> up to 450 °C | 1.21 |
| Type ELK-HS <i>Heating cable</i> up to 450 °C | 1.23 |
| Type ELW-H <i>Heating tape</i> up to 450 °C | 1.25 |
| Type ELW-HS <i>Heating tape</i> up to 450 °C | 1.27 |
| Type ELK-Q <i>Heating cable</i> up to 900 °C | 1.29 |
| Type ELW-Q <i>Heating tape</i> up to 900 °C | 1.31 |
| Type ELK-MI/F <i>Heating cable</i> up to 400 °C | 1.33 |
| Type ELK-MI/VA <i>Heating cable</i> up to 400 °C | 1.35 |
| Type ELW-3-FEP/PVC <i>Heating tape</i> up to 105 °C | 1.37 |
| Type EL-SINGLE/TWIN <i>Heating cable</i> up to 105 °C | 1.39 |
| Accessories | 1.41 |

EL-RAIL

To be found in the special heating section



Coil ware

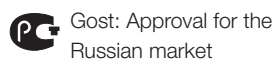

Gost: Approval for the
Russian market



Factory terminated

A reliable and competent partner with several years' experience in the field of electrical heat tracing. You wish to transfer heat to the media or compensate heat loss – eltherm® provides the solution.

Our well-founded and expert knowledge, which is based on state-of-the-art technology, is always available to you. Quality is both produced and lived at eltherm®. Moreover, we have achieved DIN ISO 9001:2000 certification.

The latest IT, planning and testing systems ensure quality and timely manufacturing processes.

In close collaboration with the customers, eltherm® develops individually tailored solutions, supporting them when planning, proposing and assembling electrical heating systems. A perfected, high-quality product programme enables eltherm® to find the most reasonable economical solution for you.

Our results are convincing.

Further documents are available with information about our high-quality products:

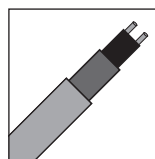

Self-regulating heating cables

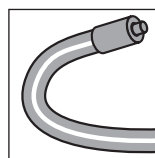

Heated hoses



Heating mats Heating jackets

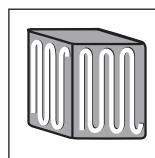

Special heating systems (for antennas, tank containers, receptacles ...)

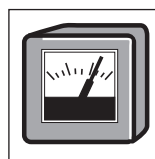

Control units, automatic control units, monitoring units and regulator systems

Important information

Products marked with the ⚠-symbol can be used in hazardous areas. The temperatures allocated to the products are the maximum permissible exposure temperatures. Our project engineers will gladly help you to design and dimension electrical heating systems. Moreover, we have prepared a questionnaire which helps to record operating data and enable correct dimensioning and allocation. We would be happy to send you the questionnaires for the respective product by fax, calculate the design data and submit you an offer. We have summarised the available accessories, fasteners and termination sets on pages 1.41 to 1.42 of the catalogue.

All products listed in the catalogue are available ex-works (subject to prior sale). All products offered in this catalogue can also be manufactured by eltherm® using different dimensions, outputs and voltages.

Furthermore, we request you to observe the following:

- All products we supply which are listed in this catalogue may only be connected and commissioned by a qualified electrician.
- All locally applicable electrical and safety regulations must be observed during installation and operation.
- Normally, electrical heating systems require a temperature control unit as it is only possible to ensure that the exposure temperatures for the electrical heating and products to be heated are not exceeded if such a unit is used.
- Electrical heating which is not or cannot be monitored when in operation needs additional temperature safeguarding which switches them off lastingly in case of a failure.
- It is only possible to go without the automatic control and / or fuse protection for all other heating products if it is ensured that the nominal temperatures are not exceeded under unfavourable conditions and / or no injuries or damages to persons and material are incurred.
- In accordance with EN 62395-1, residual current devices (RCDs) should be used for disconnection from the mains in good time and to avoid consequential damages.
- Attention: heating cable and heating tape may neither intersect nor come into contact. Danger of burning through due to reciprocal heating up.
- Our general assembly and operating instructions for this product are valid for the use of the heating cables.

Specifications and advertising messages in this products and services catalogue, irrespective of their nature, in particular descriptions, illustrations, drawings, samples, information pertaining to quality, condition, composition performance, consumption and usability as well as dimensions and weights of the product range remain subject to change in as far as they are not expressly declared as binding. They do not denote any assurance or guarantee whatsoever. Slight deviations from the product specifications shall be deemed approved in as far as they are not deemed unreasonable for the buyer.

We explicitly reserve the right to amend errors and alter technical data.



eltherm®



- Single end connection
- No cold lead required
- Can be cut to any length from the roll
- Constant power output per meter
- Highly flexible
- Suitable for the foodstuffs industry



Type **ELP/Si, -/FEP, -/PFA**



Application

Application on receptacles, pipes, valves, roofs, in roof gutters where there is a corrosive effect. Except for the end sleeve, the heating cable may be immersed in fluids. Single end power supply enables good value assembly for all heating systems. The heating cable consists of a succession of heating zones (length = contact spacing) and can be cut to length in sections of the contact distance to

the required length. When cutting into lengths, the heating circuit is interrupted up to the next contact point and this non-active part can be used as a cold lead. During the design phase, one contact spacing length per planned heating circuit must be calculated additionally.



Type **ELP/Si** up to 180 °C
 Type **ELP/FEP** up to 200 °C
 Type **ELP/PFA** up to 260 °C

Technical data:

| | | | |
|--------------------------|-------------------------|-------------------------|-------------------------|
| Type | ELP/Si | ELP/FEP | ELP/PFA |
| Outer jacket/Insulation | Silicone | FEP | PFA |
| Nominal temperature (°C) | 180 | 200 | 260 |
| Moisture resistant | yes | yes | yes |
| Minimum bending radius | 20 mm | 20 mm | 25 mm |
| Bus wire cross-section | 2 x 1.5 mm ² | 2 x 1.5 mm ² | 2 x 1.5 mm ² |
| Nominal voltage | 220 – 240 V | | |

| Type | Dimensions (mm) | Contact spacing (m) | Maximum heating circuit length (m) | Item number |
|-------------------|-----------------|---------------------|------------------------------------|-------------|
| ELP/Si 10 BO 230 | 6.8 x 10.3 | 1.2 | 135 | 0320102 |
| ELP/Si 20 BO 230 | 6.8 x 10.3 | 1.0 | 95 | 0320108 |
| ELP/Si 30 BO 230 | 6.8 x 10.3 | 1.0 | 80 | 0320114 |
| ELP/Si 40 BO 230 | 6.8 x 10.3 | 1.0 | 65 | 0320120 |
| ELP/Si 50 BO 230 | 6.8 x 10.3 | 1.0 | 60 | 0320123 |
| ELP/Si 60 BO 230 | 6.8 x 10.3 | 1.0 | 55 | 0320126 |
| ELP/FEP 10 BO 230 | 5.3 x 8.3 | 1.2 | 125 | 0320129 |
| ELP/FEP 20 BO 230 | 5.3 x 8.3 | 1.0 | 90 | 0320132 |
| ELP/FEP 30 BO 230 | 5.3 x 8.3 | 1.0 | 70 | 0320135 |
| ELP/PFA 10 BO 230 | 6.1 x 9.8 | 1.2 | 130 | 0330102 |
| ELP/PFA 20 BO 230 | 6.1 x 9.8 | 1.0 | 90 | 0330108 |
| ELP/PFA 30 BO 230 | 6.1 x 9.8 | 1.0 | 75 | 0330114 |
| ELP/PFA 40 BO 230 | 6.1 x 9.8 | 1.0 | 65 | 0330120 |
| ELP/PFA 50 BO 230 | 6.1 x 9.8 | 1.0 | 60 | 0330123 |
| ELP/PFA 60 BO 230 | 6.1 x 9.8 | 1.0 | 50 | 0330126 |

Parallel heating cables up to nominal voltages of 400 V available upon request.
 Bus wire cross-section 2 x 2 mm² upon request.

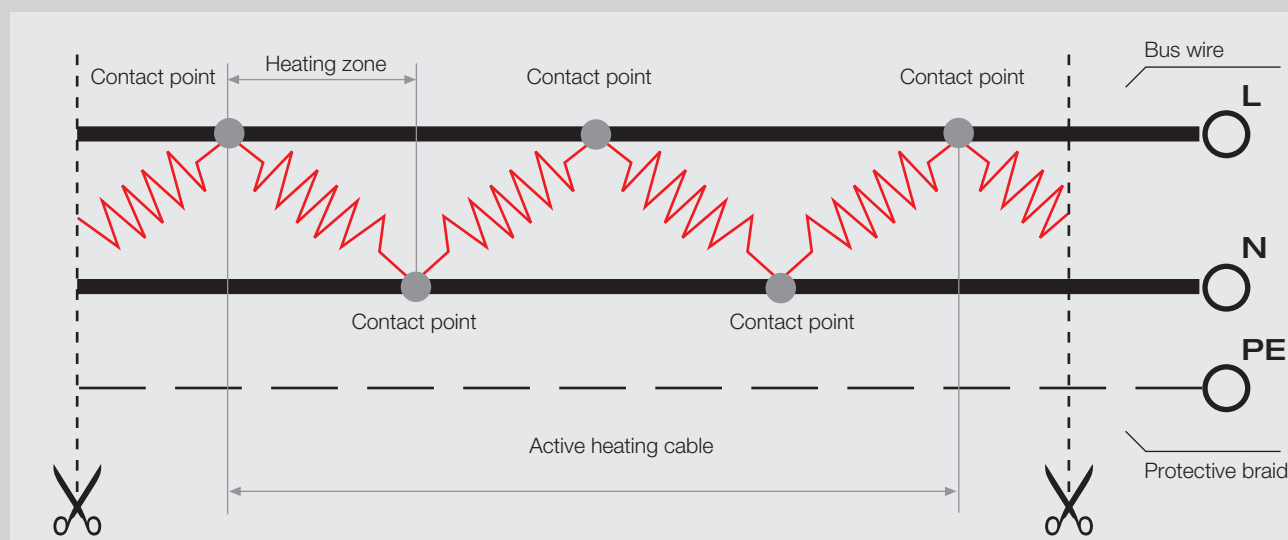
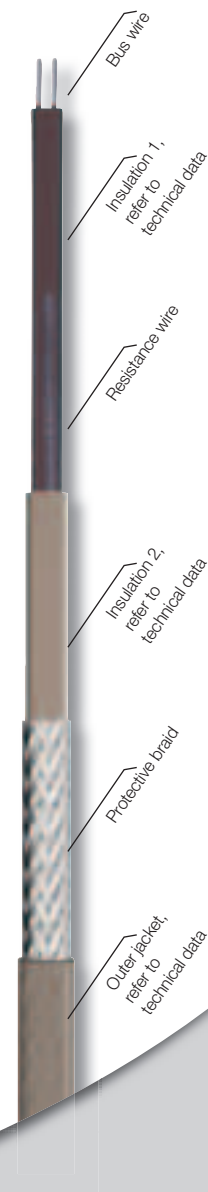

4/2009 · We reserve the right to make changes

eltherm®



- Highly flexible
- Can be used in almost all industrial areas
- Lowest bending radius
- Very high working temperature
- High chemical resistance
- Moisture resistant



Gost



Type **ELKM-A, -AS, -AE**

Application

Use on devices, receptacles, pipes, valves etc., in which low bending radii also allow compact tracing on small components across the entire surface. The heating cable is also available with corrosion-proof braiding consisting of SS AISI 304 which is named **ELKM-AE**.

This heating cable is also available without braiding under the name ELKM-A for use in devices and under metallic covers.



Type ELKM-A, -AS, -AE up to 260 °C

Standards:

Manufactured according to DIN VDE 0253
 Short term NH5Y11Q220
 VDE reg. no. 7615 (ELKM-AS)

Technical data:

Insulation PTFE
 Protective braid Cu nickel-plated at ELKM-AS
 SS AISI 304 at ELKM-AE
 Nominal voltage max. 500 V
 Output max. 30 W/m*
 Operating temperature max.. 260 °C when switched off
 Minimum bending radius. . . 5 x External-Ø
 Minimum installation temperature – 50 °C
 Moisture resistant yes

* Information: The output per meter of heating cable and the maximum possible working temperatures depend on the respective application. We recommend that you contact our engineers on an individual basis – we will gladly assist you.

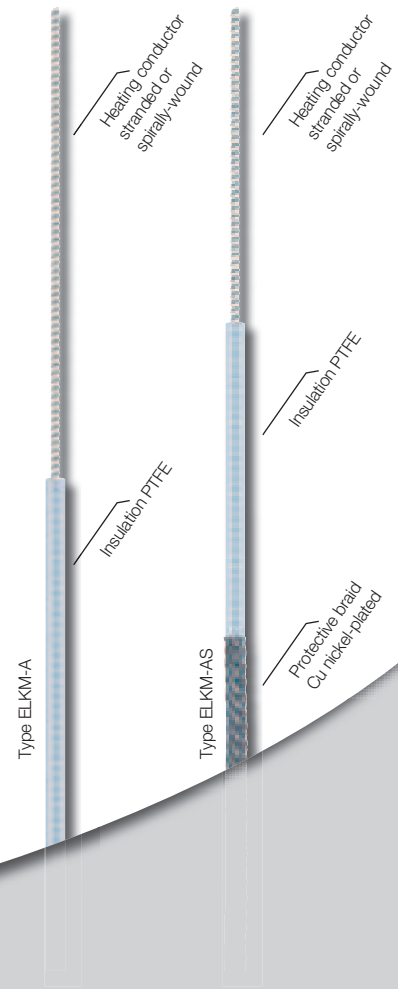

| Nominal resistance (Ω/km) | Outer diameter (mm) | Heating cable design | Temperature coefficient (1/K) α 105 °C | Item number |
|---------------------------|---------------------|----------------------|--|-------------|
| 1.95 | 5.68 | Stranded | 0.00430 | 0137001 |
| 2.90 | 4.78 | Stranded | 0.00430 | 0137003 |
| 4.40 | 4.18 | Stranded | 0.00430 | 0137005 |
| 7.20 | 3.68 | Stranded | 0.00430 | 0137006 |
| 10.00 | 3.38 | Stranded | 0.00430 | 0137008 |
| 11.70 | 3.28 | Stranded | 0.00430 | 0137011 |
| 15.00 | 3.08 | Stranded | 0.00430 | 0137013 |
| 25.00 | 2.98 | Stranded | 0.00300 | 0137017 |
| 31.50 | 3.28 | Stranded | 0.00160 | 0137021 |
| 50.00 | 2.98 | Stranded | 0.00160 | 0137031 |
| 65.00 | 2.78 | Stranded | 0.00160 | 0137033 |
| 80.00 | 3.08 | Stranded | 0.00090 | 0137039 |
| 100.00 | 2.98 | Stranded | 0.00090 | 0137043 |
| 157.00 | 2.98 | Stranded | 0.00045 | 0137044 |
| 180.00 | 2.68 | Stranded | 0.00090 | 0137053 |
| 200.00 | 2.78 | Stranded | 0.00045 | 0137055 |
| 260.00 | 2.68 | Stranded | 0.00045 | 0137059 |

| Nominal resistance (Ω/km) | Outer diameter (mm) | Heating cable design | Temperature coefficient (1/K) α 105 °C | Item number |
|---------------------------|---------------------|----------------------|--|-------------|
| 280.00 | 2.58 | Stranded | 0.00038 | 0137230 |
| 328.00 | 2.88 | Stranded | 0.00018 | 0137231 |
| 360.00 | 2.48 | Stranded | 0.00045 | 0137084 |
| 430.00 | 2.68 | Stranded | 0.00018 | 0137067 |
| 480.00 | 2.68 | Stranded | 0.00018 | 0137068 |
| 600.00 | 2.58 | Stranded | 0.00018 | 0137232 |
| 800.00 | 2.48 | Stranded | 0.00018 | 0137081 |
| 1000.00 | 2.58 | Stranded | 0.00004 | 0137083 |
| 1470.00 | 2.38 | Stranded | 0.00004 | 0137233 |
| 1750.00 | 2.38 | Stranded | 0.00004 | 0137234 |
| 1900.00 | 2.68 | Stranded | 0.00040 | 0137235 |
| 2900.00 | 2.48 | Stranded | 0.00040 | 0137104 |
| 4000.00 | 2.38 | Stranded | 0.00040 | 0137115 |
| 4700.00 | 2.28 | Stranded | 0.00015 | 0137119 |
| 6000.00 | 2.18 | Stranded | 0.00020 | 0137236 |
| 7000.00 | 2.18 | Stranded | 0.00015 | 0137127 |
| 8000.00 | 2.18 | Stranded | 0.00015 | 0137121 |

Further resistances up to 1,500,000 Ω/Km upon request

4/2009 · We reserve the right to make changes



eltherm®

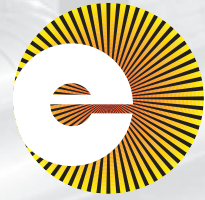

- High chemical resistance
- Can be used in all industrial areas
- Minimum impact resistance 4 Joules
- High working temperature
- Can be immersed in fluids



Type **ELKM-AG-L**

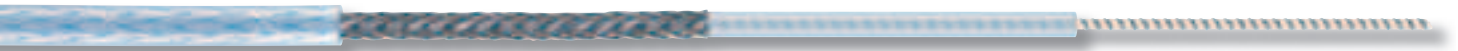

Application

The heating cable is suitable for highly corrosive environmental conditions for assembly on devices, receptacles, pipes, valves and similar. Except for the splices, it may be immersed in fluids. The robust PTFE outer jacket also

renders this heating cable resistant against aggressive chemicals.



Type **ELKM-AG-L** up to 260 °C

Standards:

Manufactured according to DIN VDE 0253, EN 62395-1
 Short term NH5Y1Q5Y 220
 VDE marks approval 40001594, 40024940

Technical data:

Insulation PTFE
 Protective braid Cu nickel-plated
 Outer jacket PTFE
 Nominal voltage 500 V
 Output max 30 W/m*
 Operating temperature max.: 260 °C when switched off
 Minimum bending radius. 5 x External-Ø
 Minimum installation temperature – 50 °C
 Moisture resistant yes
 Impact resistance 4 Joule

* Information: The output per meter of heating cable and the maximum possible working temperatures depend on the respective application. We recommend that you contact our engineers on an individual basis – we will gladly assist you.

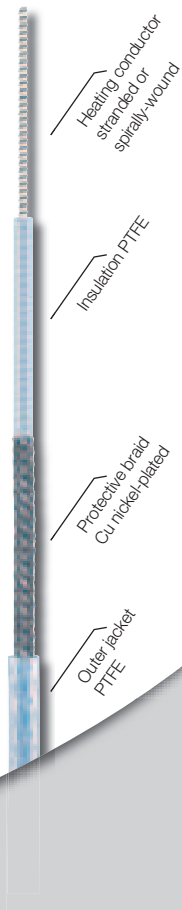

| Nominal resistance (Ω/km) | Outer diameter (mm) | Heating cable design | Temperature coefficient (1/K) | Item number |
|---------------------------|---------------------|----------------------|-------------------------------|-------------|
| 1.95 | 6.64 | Stranded | 0.00430 | 01TT002E |
| 2.90 | 5.74 | Stranded | 0.00430 | 01TT003E |
| 4.40 | 5.14 | Stranded | 0.00430 | 01TT004E |
| 7.20 | 4.64 | Stranded | 0.00430 | 01TT007E |
| 10.00 | 4.34 | Stranded | 0.00430 | 01TT010E |
| 11.70 | 4.24 | Stranded | 0.00430 | 01TT011E |
| 15.00 | 4.04 | Stranded | 0.00430 | 01TT015E |
| 25.00 | 3.94 | Stranded | 0.00300 | 01TT025E |
| 31.50 | 4.24 | Stranded | 0.00160 | 01TT031E |
| 50.00 | 3.94 | Stranded | 0.00160 | 01TT050E |
| 65.00 | 3.74 | Stranded | 0.00160 | 01TT065E |
| 80.00 | 4.04 | Stranded | 0.00090 | 01TT080E |
| 100.00 | 3.94 | Stranded | 0.00090 | 01TT110E |
| 157.00 | 3.94 | Stranded | 0.00045 | 01TT115E |
| 180.00 | 3.64 | Stranded | 0.00090 | 01TT118E |
| 200.00 | 3.74 | Stranded | 0.00045 | 01TT120E |
| 260.00 | 3.64 | Stranded | 0.00045 | 01TT126E |

| Nominal resistance (Ω/km) | Outer diameter (mm) | Heating cable design | Temperature coefficient (1/K) | Item number |
|---------------------------|---------------------|----------------------|-------------------------------|-------------|
| 280.00 | 3.54 | Stranded | 0.00038 | 01TT128E |
| 328.00 | 3.84 | Stranded | 0.00018 | 01TT132E |
| 360.00 | 3.44 | Stranded | 0.00045 | 01TT138E |
| 430.00 | 3.64 | Stranded | 0.00018 | 01TT143E |
| 480.00 | 3.64 | Stranded | 0.00018 | 01TT148E |
| 600.00 | 3.54 | Stranded | 0.00018 | 01TT160E |
| 800.00 | 3.44 | Stranded | 0.00018 | 01TT180E |
| 1000.00 | 3.54 | Stranded | 0.00004 | 01TT210E |
| 1470.00 | 3.34 | Stranded | 0.00004 | 01TT214E |
| 1750.00 | 3.34 | Stranded | 0.00004 | 01TT217E |
| 1900.00 | 3.64 | Stranded | 0.00040 | 01TT219E |
| 2900.00 | 3.44 | Stranded | 0.00040 | 01TT229E |
| 4000.00 | 3.34 | Stranded | 0.00040 | 01TT240E |
| 4700.00 | 3.24 | Stranded | 0.00015 | 01TT247E |
| 6000.00 | 3.14 | Stranded | 0.00020 | 01TT260E |
| 7000.00 | 3.14 | Stranded | 0.00015 | 01TT270E |
| 8000.00 | 3.14 | Stranded | 0.00015 | 01TT280E |

Further resistances up to 1,500,000 Ω/Km upon request

4/2009 · We reserve the right to make changes

eltherm®



- High chemical resistance
- Can be used in all industrial areas
- Minimum impact resistance 4 Joules
- High working temperature
- Can be immersed in fluids



Gost



Type ELKM-AG-N



Application

The heating cable is suitable for highly corrosive environmental conditions for assembly on devices, receptacles, pipes, valves and similar. Except for the splices, it may be immersed in fluids. Heating cable ELKM-AG is also suit-

able for use in the hazardous area. The robust PTFE outer jacket also renders this heating cable resistant against aggressive chemicals.



Type **ELKM-AG-N** up to 260 °C

Standards:

Manufactured according to DIN VDE 0253, EN 62395-1
 Short term NH5Y1Q5Y 220
 VDE marks approval 40001594, 40024940
 ATEX certificate . . . LCIE 01 ATEX 6048 X
 Equipment category  II 2G EEx e II T3, T4, T5

Technical data:

Insulation PTFE
 Protective braid Cu nickel-plated
 Outer jacket PFA
 Nominal voltage 500 V
 Output max 30 W/m*
 Operating temperature max.: 260 °C when switched off
 Minimum bending radius. . . . 5 x External-Ø
 Minimum installation temperature - 50 °C
 Moisture resistant yes
 Impact resistance 4 Joule

* Information: The output per meter of heating cable and the maximum possible working temperatures depend on the respective application. We recommend that you contact our engineers on an individual basis – we will gladly assist you.

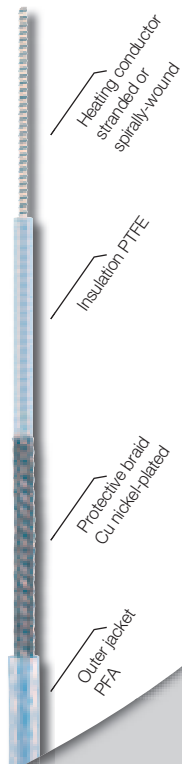

| Nominal resistance (Ω/km) | Outer diameter (mm) | Heating cable design | Temperature coefficient (1/K) | Item number |
|---------------------------|---------------------|----------------------|-------------------------------|-------------|
| 1.95 | 7.04 | Stranded | 0.00430 | 01TA002E |
| 2.90 | 6.14 | Stranded | 0.00430 | 01TA003E |
| 4.40 | 5.54 | Stranded | 0.00430 | 01TA004E |
| 7.20 | 5.04 | Stranded | 0.00430 | 01TA007E |
| 10.00 | 4.74 | Stranded | 0.00430 | 01TA010E |
| 11.70 | 4.64 | Stranded | 0.00430 | 01TA011E |
| 15.00 | 4.44 | Stranded | 0.00430 | 01TA015E |
| 25.00 | 4.34 | Stranded | 0.00300 | 01TA025E |
| 31.50 | 4.64 | Stranded | 0.00160 | 01TA031E |
| 50.00 | 4.34 | Stranded | 0.00160 | 01TA050E |
| 65.00 | 4.14 | Stranded | 0.00160 | 01TA065E |
| 80.00 | 4.44 | Stranded | 0.00090 | 01TA080E |
| 100.00 | 4.34 | Stranded | 0.00090 | 01TA110E |
| 157.00 | 4.34 | Stranded | 0.00045 | 01TA115E |
| 180.00 | 4.04 | Stranded | 0.00090 | 01TA118E |
| 200.00 | 4.14 | Stranded | 0.00045 | 01TA120E |
| 260.00 | 4.04 | Stranded | 0.00045 | 01TA126E |

| Nominal resistance (Ω/km) | Outer diameter (mm) | Heating cable design | Temperature coefficient (1/K) | Item number |
|---------------------------|---------------------|----------------------|-------------------------------|-------------|
| 280.00 | 3.94 | Stranded | 0.00038 | 01TA128E |
| 328.00 | 4.24 | Stranded | 0.00018 | 01TA132E |
| 360.00 | 3.84 | Stranded | 0.00045 | 01TA138E |
| 430.00 | 4.04 | Stranded | 0.00018 | 01TA143E |
| 480.00 | 4.04 | Stranded | 0.00018 | 01TA148E |
| 600.00 | 3.94 | Stranded | 0.00018 | 01TA160E |
| 800.00 | 3.84 | Stranded | 0.00018 | 01TA180E |
| 1000.00 | 3.94 | Stranded | 0.00004 | 01TA210E |
| 1470.00 | 3.74 | Stranded | 0.00004 | 01TA214E |
| 1750.00 | 3.74 | Stranded | 0.00004 | 01TA217E |
| 1900.00 | 4.04 | Stranded | 0.00040 | 01TA219E |
| 2900.00 | 3.84 | Stranded | 0.00040 | 01TA229E |
| 4000.00 | 3.74 | Stranded | 0.00040 | 01TA240E |
| 4700.00 | 3.64 | Stranded | 0.00015 | 01TA247E |
| 6000.00 | 3.54 | Stranded | 0.00020 | 01TA260E |
| 7000.00 | 3.54 | Stranded | 0.00015 | 01TA270E |
| 8000.00 | 3.54 | Stranded | 0.00015 | 01TA280E |

Further resistances up to 1,500,000 Ω/Km upon request

4/2009 · We reserve the right to make changes

eltherm®



- Factory terminated
- Low bending radius
- Highly flexible
- Very high working temperature
- Can be used in almost all industrial areas
- High chemical resistance
- Moisture resistant



Type **ELK-AS, -AE**

Application

Use on devices, receptacles, pipes, valves etc. with low corrosive effects, in which low bending radii also allow compact tracing on small components across the entire surface. Environmental conditions which corrode the braiding must be avoided. The heating cable is also avail-

able with corrosion-proof braiding consisting of SS AISI 304 under the name of: ELKM-AE.



Type **ELK-AS, -AE** up to 260 °C

Standards:

Manufactured according to DIN VDE 0253
 Short term NH5Y1Q220
 VDE reg. no. 7615 (ELK-AS)
 Final inspection according to DIN VDE 0721 T 411
 2.5 kV AC – 1 min

Technical data:

Outer jacket PTFE
 Protective braid Cu nickel-plated
 Option SS AISI 304
 Nominal voltage 230 V
 Output max 25 W/m
 Operating temperature max.. 260 °C when switched off
 Heating cable Ø 3.1 – 3.6 mm
 Minimum bending radius. 5 x External-Ø
 Minimum installation temperature – 50 °C
 Moisture resistant yes
 Cold lead length on both sides 1.2 m
 Protection class I

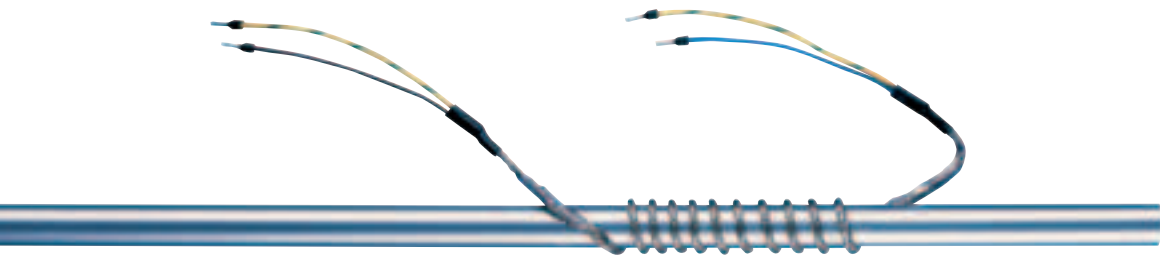
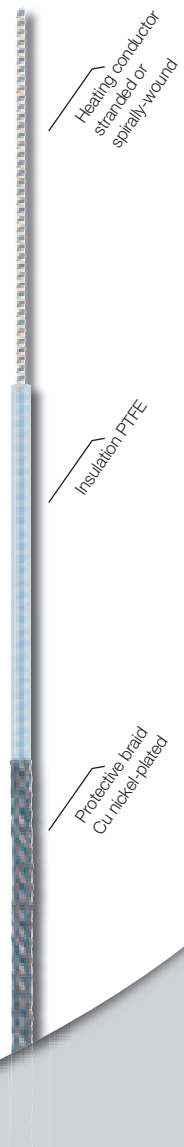

| Item name | Heated length (m) | Nominal output (W) max. Temperature 100 °C | Item number | Nominal output (W) max. Temperature 150 °C | Item number | Nominal output (W) max. Temperature 200 °C | Item number |
|-------------|-------------------|--|-------------|--|-------------|--|-------------|
| ELK-AS 1.2 | 1.2 | 30 | 0134011 | – | | – | |
| ELK-AS 2.2 | 2.2 | 54 | 0134021 | – | | – | |
| ELK-AS 3.4 | 3.4 | 78 | 0134031 | 52 | 0134032 | 24 | 0134033 |
| ELK-AS 4.8 | 4.8 | 94 | 0134041 | 69 | 0134042 | 37 | 0134043 |
| ELK-AS 6.0 | 6.0 | 147 | 0134061 | 88 | 0134062 | 44 | 0134063 |
| ELK-AS 8.4 | 8.4 | 210 | 0134081 | 126 | 0134082 | 63 | 0134083 |
| ELK-AS 10.8 | 10.8 | 245 | 0134101 | 163 | 0134102 | 82 | 0134103 |
| ELK-AS 12.0 | 12.0 | 294 | 0134121 | 176 | 0134122 | 88 | 0134123 |
| ELK-AS 14.0 | 14.0 | 344 | 0134141 | – | | – | |
| ELK-AS 20 | 20.0 | 464 | 0134201 | 294 | 0134202 | – | |
| ELK-AS 25 | 25.0 | 623 | 0134251 | 371 | 0134252 | 192 | 0134253 |
| ELK-AS 30 | 30.0 | 705 | 0134301 | 441 | 0134302 | 220 | 0134303 |
| ELK-AS 35 | 35.0 | 864 | 0134351 | 521 | 0134352 | – | |
| ELK-AS 42.0 | 42.0 | 1.008 | 0134421 | 611 | 0134422 | 315 | 0134423 |
| ELK-AS 56.0 | 56.0 | 1.390 | 0134561 | 756 | 0134562 | 378 | 0134563 |

Further resistances available upon request; all output information are nominal outputs at + 20 °C

eltherm®

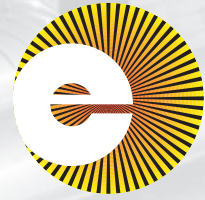

- Factory terminated
- High chemical resistance
- Can be used in all industrial areas
- Minimum impact resistance 4 Joules
- High working temperature
- Can be immersed in fluids



Type ELK-AG



Application

Factory terminated heating cable, suitable for assembly on devices, receptacles, pipes, valves and similar with a highly corrosive environment. Except for the connection sleeve, it may be immersed in fluids. Heating cable ELK-AG is also

suitable for use in the hazardous area. The robust PTFE outer jacket also renders this heating cable also resistant against aggressive chemicals.



Type **ELK-AG** up to 260 °C

Standards:

Manufactured according to DIN VDE 0253, EN 62395-1
 Short term NH5Y1Q5Y 220
 VDE marks approval. 40001594, 40024940
 ATEX certificate . . . LCIE 01 ATEX 6048 X
 Equipment category  II 2G EEx e II T3, T4, T5

Technical data:

Insulation PTFE
 Protective braid Cu nickel-plated
 Outer jacket PTFE
 Nominal voltage 230 V
 Output approx. 25 W/m
 Operating temperature max.. 260 °C when switched off
 Heating cable Ø 4.1 – 4.8 mm
 Minimum bending radius. 5 x External-Ø
 Moisture resistant yes
 Cold lead length on both sides 1.2 m
 Protection class I
 Impact resistance 4 Joule

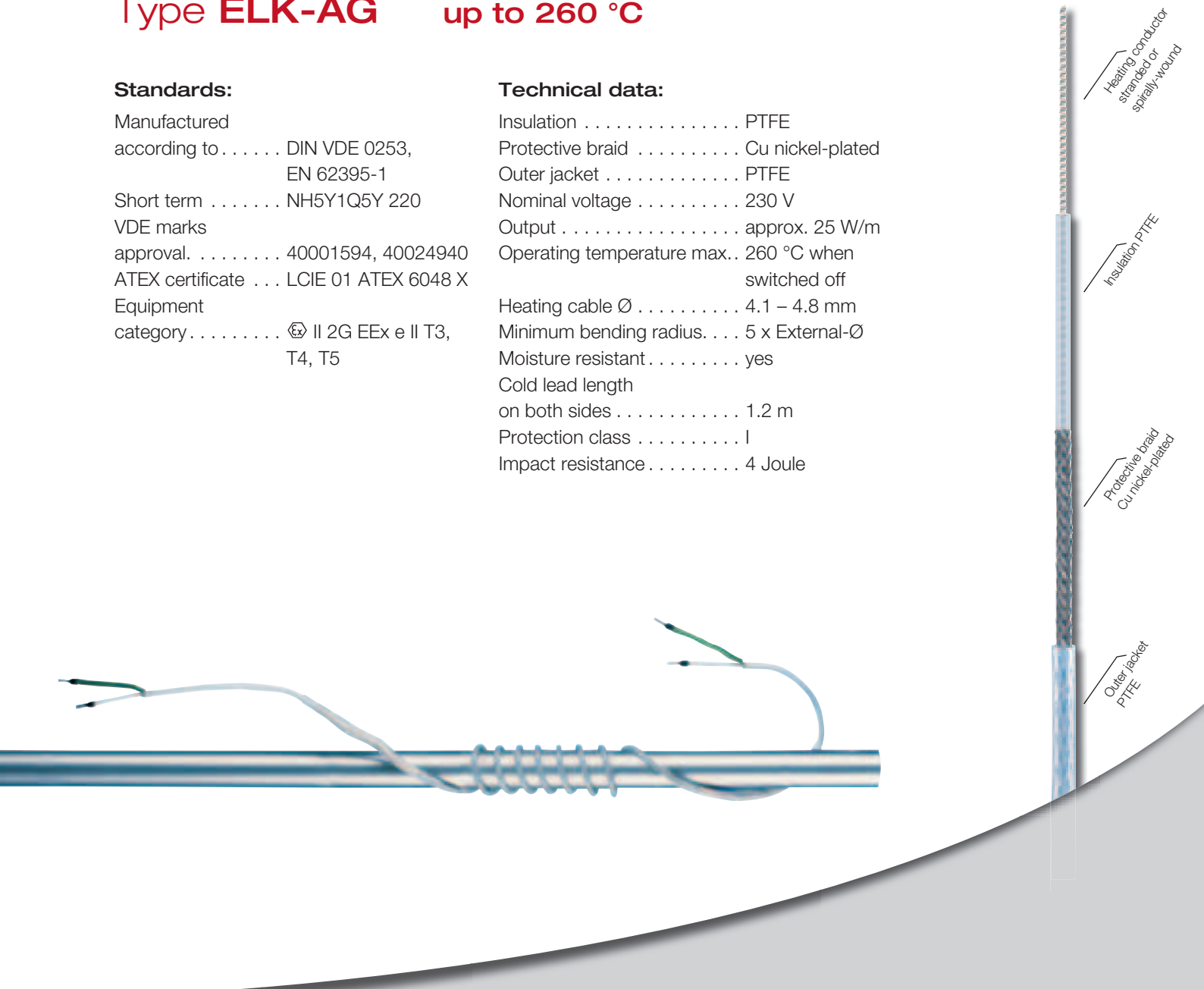

| Item name | Heated length (m) | Nominal output (W) max. Temperature 100 °C | Item number | Nominal output (W) max. Temperature 150 °C | Item number | Nominal output (W) max. Temperature 200 °C | Item number |
|-------------|-------------------|--|-------------|--|-------------|--|-------------|
| ELK-AG 1.2 | 1.2 | 30 | 0135011 | – | | – | |
| ELK-AG 2.2 | 2.2 | 54 | 0135021 | – | | – | |
| ELK-AG 3.4 | 3.4 | 78 | 0135031 | 52 | 0135032 | 24 | 0135033 |
| ELK-AG 4.8 | 4.8 | 94 | 0135041 | 69 | 0135042 | 37 | 0135043 |
| ELK-AG 6.0 | 6.0 | 147 | 0135061 | 88 | 0135062 | 44 | 0135063 |
| ELK-AG 8.4 | 8.4 | 210 | 0135081 | 126 | 0135082 | 63 | 0135083 |
| ELK-AG 10.8 | 10.8 | 245 | 0135101 | 163 | 0135102 | 82 | 0135103 |
| ELK-AG 12.0 | 12.0 | 294 | 0135121 | 176 | 0135122 | 88 | 0135123 |
| ELK-AG 14.0 | 14.0 | 344 | 0135141 | – | | – | |
| ELK-AG 20 | 20.0 | 464 | 0135201 | 294 | 0135202 | – | |
| ELK-AG 25 | 25.0 | 623 | 0135251 | 371 | 0135252 | 192 | 0135253 |
| ELK-AG 30 | 30.0 | 705 | 0135301 | 441 | 0135302 | 220 | 0135303 |
| ELK-AG 35 | 35.0 | 864 | 0135351 | 521 | 0135352 | – | |
| ELK-AG 42.0 | 42.0 | 1.008 | 0135421 | 611 | 0135422 | 315 | 0135423 |
| ELK-AG 56.0 | 56.0 | 1.390 | 0135561 | 756 | 0135562 | 378 | 0135563 |

Further resistances available upon request; all output information are nominal outputs at + 20 °C



eltherm®



- Factory terminated
- Can be used instantly
- Single end connection
- Highly flexible
- Gentle to surfaces
- Low bending radius
- Easy to assemble
- Moisture resistant



Type **ELW-GN**

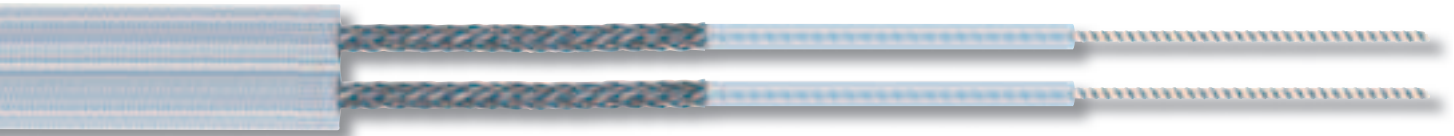

Application

The factory terminated heating tape ELW-GN is suitable for heating apparatus, devices and systems in a non-corrosive environment and its preferred use is for glass

devices and systems with sensitive surfaces. This heating tape is also available upon request for hazardous area applications.



Type **ELW-GN** up to 260 °C

Standards:

Manufactured according to DIN VDE 0721
 Short term based on DIN VDE 0253 NH5YIQMF 220
 VDE reg. no. 7615
 Final inspection according to DIN VDE 0721 T411
 2.5 kV AC – 1 min

Technical data:

Insulation PTFE
 Protective braid Cu nickel-plated
 Outer jacket textiles E-Glas
 Nominal voltage 230 V
 Output approx. 50 W/m*
 Operating temperature max. 260 °C when switched off
 Dimensions (W x H) approx. 25 x 6 mm
 Bending radius flat minimum 10 mm
 Minimum installation temperature – 50 °C
 Moisture resistant yes
 Connection 1.2 m without plug
 Protection class I

* Information: The output per meter of heating cable and the maximum possible working temperatures depend on the respective application. We recommend that you contact our engineers on an individual basis – we will gladly assist you.

Also available upon request for hazardous area applications.

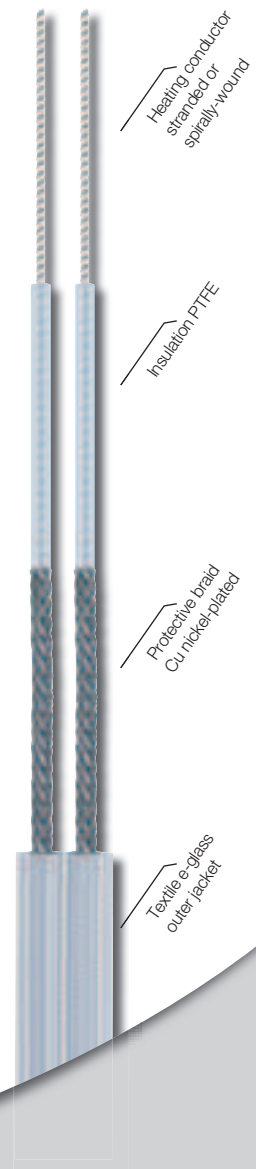

| Item name | Heated length (m) | Nominal output (W) max. Temperature 100 °C | Item number | Nominal output (W) max. Temperature 150 °C | Item number | Nominal output (W) max. Temperature 200 °C | Item number |
|-------------|-------------------|--|-------------|--|-------------|--|-------------|
| ELW-GN 0.6 | 0.6 | 30 | 0231001 | – | | – | |
| ELW-GN 1.1 | 1.1 | 54 | 0231011 | – | | – | |
| ELW-GN 1.7 | 1.7 | 78 | 0231701 | 52 | 0231012 | 24 | 0231013 |
| ELW-GN 2.4 | 2.4 | 94 | 0231021 | 69 | 0231022 | 37 | 0231023 |
| ELW-GN 3.0 | 3.0 | 147 | 0231031 | 88 | 0231032 | 44 | 0231033 |
| ELW-GN 4.2 | 4.2 | 210 | 0231041 | 126 | 0231042 | 63 | 0231043 |
| ELW-GN 5.4 | 5.4 | 245 | 0231051 | 163 | 0231052 | 82 | 0231053 |
| ELW-GN 6.0 | 6.0 | 294 | 0231061 | 176 | 0231062 | 88 | 0231063 |
| ELW-GN 7.0 | 7.0 | 344 | 0231071 | – | | – | |
| ELW-GN 10.0 | 10.0 | 464 | 0231101 | 294 | 0231102 | – | |
| ELW-GN 12.5 | 12.5 | 623 | 0231121 | 371 | 0231122 | 192 | 0231123 |
| ELW-GN 15.0 | 15.0 | 705 | 0231151 | 441 | 0231152 | 220 | 0231153 |
| ELW-GN 17.5 | 17.5 | 864 | 0231171 | 521 | 0231172 | – | |
| ELW-GN 21.0 | 21.0 | 1.008 | 0231211 | 611 | 0231212 | 315 | 0231213 |
| ELW-GN 28.0 | 28.0 | 1.390 | 0231281 | 756 | 0231282 | 378 | 0231283 |

Further resistances available upon request; all output information are nominal outputs at + 20 °C

eltherm®



- Factory terminated
- Can be used instantly
- Single end connection
- Highly flexible
- Low bending radius
- Low dimension
- Robust
- Easy to assemble
- Moisture resistant



Type ELW-VA

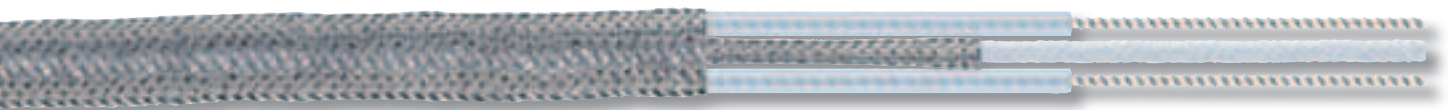

Application

The factory terminated heating tape ELW-VA is suitable for heating apparatus, devices and systems in a corrosive environment. The minimal dimensions of the heating tape enable close tracing. The heating tape is not sensitive to

rough surfaces. This heating tape is also available upon request for hazardous area applications.





eltherm®



- Factory terminated
- High output
- Can be used instantly
- Highly flexible
- Low bending radius
- Low dimension
- Easy to assemble



Type **ELK-H**

Application

The factory terminated heating cable ELK-H is suitable for heating apparatus, devices and systems in a dry environ-

ment with protected installation. Preferably used for glass devices and systems with high output requirements.



Type ELK-H up to 450 °C

Standards:

Manufactured according to DIN VDE 0721 T2
 Short term based on DIN VDE 0253 NHMF 500
 Final inspection according to DIN VDE 0721 T2
 1.5 kV AC – 1 min

Technical data:

Insulation Textile e-glass
 Nominal voltage 230 V
 Output ~ 125 W/m*
 Operating temperature max. 450 °C when switched off
 Diameter 3.5 – 4.5 mm
 Minimum bending radius 8 mm
 Minimum installation temperature Not restricted
 Moisture resistant no
 Cold end length 1.2 m
 Protection class determined by installation

* Information: The output per meter of heating cable and the maximum possible working temperatures depend on the respective application. We recommend that you contact our engineers on an individual basis – we will gladly assist you.

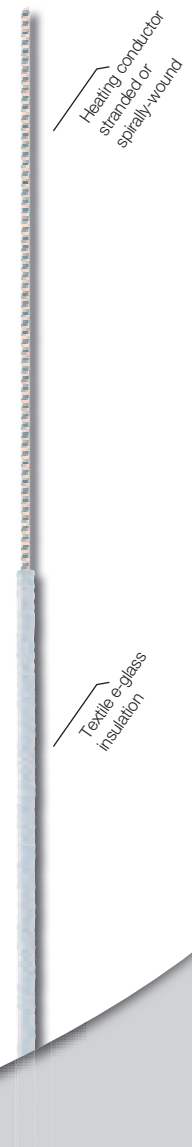

| Item name | Heated length (m) | Output approx. (W) | RL Ω/m | Item number |
|-----------|-------------------|--------------------|---------|-------------|
| ELK-H 0.5 | 0.5 | 60 | 1700.00 | 0140002 |
| ELK-H 1.0 | 1.0 | 126 | 420.00 | 0140005 |
| ELK-H 1.4 | 1.4 | 180 | 210.00 | 0140008 |
| ELK-H 2.2 | 2.2 | 240 | 100.00 | 0140012 |
| ELK-H 3.0 | 3.0 | 375 | 47.00 | 0140014 |
| ELK-H 4.2 | 4.2 | 504 | 25.00 | 0140018 |

| Item name | Heated length (m) | Output approx. (W) | RL Ω/m | Item number |
|------------|-------------------|--------------------|--------|-------------|
| ELK-H 5.0 | 5.0 | 622 | 17.00 | 0140020 |
| ELK-H 6.5 | 6.5 | 768 | 10.60 | 0140024 |
| ELK-H 8.5 | 8.5 | 1090 | 5.71 | 0140027 |
| ELK-H 10.0 | 10.0 | 1336 | 3.96 | 0140029 |
| ELK-H 13.5 | 13.5 | 1757 | 2.23 | 0140033 |
| ELK-H 16.5 | 16.5 | 2030 | 1.58 | 0140036 |

Further resistances available upon request



eltherm®



- Factory terminated
- Increased safety due to Protective braid
- High output
- Can be used instantly
- Highly flexible
- Low bending radius
- Low dimension
- Easy to assemble



Type **ELK-HS**



Application

For heating apparatus, devices and systems in a dry environment. Preferably used for devices and systems with high output requirements. Low dimensions and high flexibility simplify assembly. The outer braiding provides

protection against mechanical damages and can be incorporated in the electrical protection measures.



Type ELK-HS up to 450 °C

Standards:

Manufactured according to DIN VDE 0721 T2
 Short term based on DIN VDE 0253 NHMFQ 500
 Final inspection according to DIN VDE 0721 T2
 1.5 kV AC – 1 min

Technical data:

Insulation Textile e-glass
 Protective braid SS AISI 304
 Nominal voltage 230 V
 Output ~ 125 W/m*
 Operating temperature max. 450 °C when switched off
 Diameter 4.5 mm
 Minimum bending radius 8 mm
 Minimum installation temperature Not restricted
 Moisture resistant no
 Cold lead length on both sides 1.2 m
 Protection class I

* Information: The output per meter of heating cable and the maximum possible working temperatures depend on the respective application. We recommend that you contact our engineers on an individual basis – we will gladly assist you.

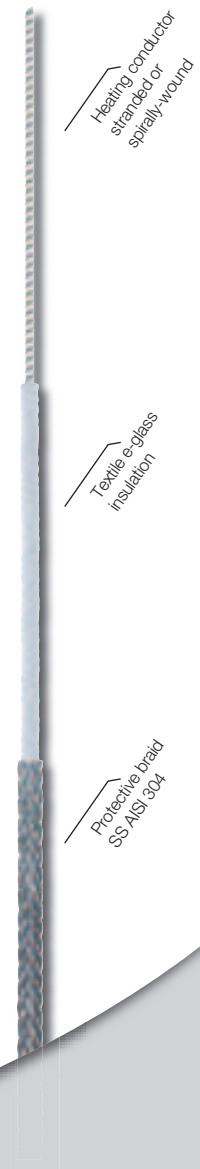
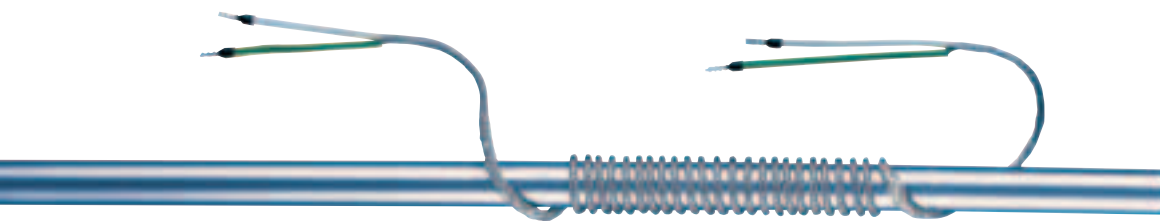

| Item name | Heated length (m) | Output approx. (W) | RL Ω/m | Item number |
|------------|-------------------|--------------------|---------|-------------|
| ELK-HS 0.5 | 0.5 | 60 | 1700.00 | 0140102 |
| ELK-HS 1.0 | 1.0 | 126 | 420.00 | 0140105 |
| ELK-HS 1.4 | 1.4 | 180 | 210.00 | 0140108 |
| ELK-HS 2.2 | 2.2 | 240 | 100.00 | 0140112 |
| ELK-HS 3.0 | 3.0 | 375 | 47.00 | 0140114 |
| ELK-HS 4.2 | 4.2 | 504 | 25.00 | 0140118 |

| Item name | Heated length (m) | Output approx. (W) | RL Ω/m | Item number |
|-------------|-------------------|--------------------|--------|-------------|
| ELK-HS 5.0 | 5.0 | 622 | 17.00 | 0140120 |
| ELK-HS 6.5 | 6.5 | 768 | 10.60 | 0140124 |
| ELK-HS 8.5 | 8.5 | 1090 | 5.71 | 0140130 |
| ELK-HS 10.0 | 10.0 | 1336 | 3.96 | 0140129 |
| ELK-HS 13.5 | 13.5 | 1757 | 2.23 | 0140133 |
| ELK-HS 16.5 | 16.5 | 2030 | 1.58 | 0140136 |

Further resistances available upon request



eltherm®



- Factory terminated
- Can be used instantly
- Single end connection
- High output
- Highest flexibility
- Gentle to surfaces
- Low bending radius
- Good value
- Easy to assemble



Type **ELW-H**

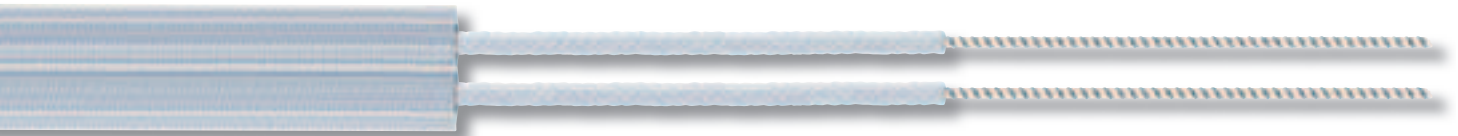

Application

It is used to heat glass, quartz or ceramic devices and systems in a non-corrosive and dry environment. The tape is highly flexible, does not damage the surfaces and is suitable for high output applications. The heating tape

should be protected mechanically and adjacent metallic parts should be incorporated in the electrical protection measures.



Type **ELW-H** up to 450 °C

Standards:

Manufactured according to DIN VDE 0721 T2
 Short term based on DIN VDE 0253 NHMFMMF 500
 Final inspection according to DIN VDE 0721 T411
 1.5 kV AC – 1 min

Technical data:

Insulation Textile e-glass
 Outer jacket Textile e-glass
 Nominal voltage 230 V
 Output ~ 250 W/m*
 Operating temperature max. 450 °C when switched off
 Dimensions (W x H) 30 x 5 mm
 Bending radius flat minimum 10 mm
 Minimum installation temperature Not restricted
 Moisture resistant no
 Connection 1.2 m without plug
 Protection class determined by installation

* Information: The output per meter of heating cable and the maximum possible working temperatures depend on the respective application. We recommend that you contact our engineers on an individual basis – we will gladly assist you.

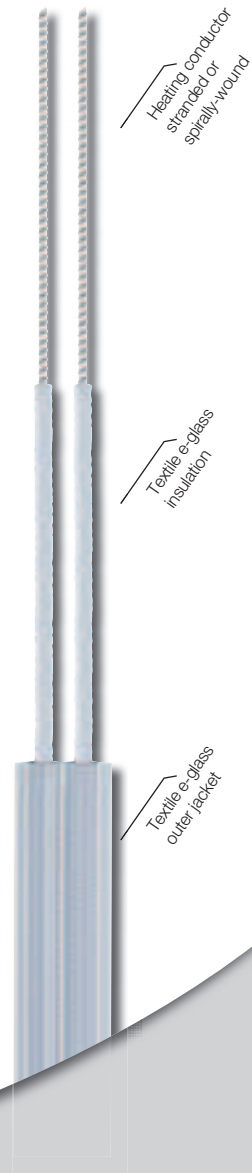

| Item name | Heated length (m) | Output approx. (W) | RL Ω/m | Item number |
|------------|-------------------|--------------------|--------|-------------|
| ELW-H 0.50 | 0.50 | 122 | 420.00 | 0240002 |
| ELW-H 0.70 | 0.70 | 175 | 210.00 | 0240005 |
| ELW-H 1.10 | 1.10 | 240 | 100.00 | 0240009 |
| ELW-H 1.50 | 1.50 | 375 | 47.00 | 0240011 |
| ELW-H 2.10 | 2.10 | 504 | 25.00 | 0240015 |
| ELW-H 2.50 | 2.50 | 622 | 17.00 | 0240017 |

| Item name | Heated length (m) | Output approx. (W) | RL Ω/m | Item number |
|------------|-------------------|--------------------|--------|-------------|
| ELW-H 3.25 | 3.25 | 768 | 10.60 | 0240021 |
| ELW-H 4.25 | 4.25 | 1090 | 5.71 | 0240024 |
| ELW-H 5.00 | 5.00 | 1336 | 3.96 | 0240026 |
| ELW-H 6.75 | 6.75 | 1757 | 2.23 | 0240030 |
| ELW-H 8.25 | 8.25 | 2030 | 1.58 | 0240033 |

Further resistances available upon request

eltherm®



- Factory terminated
- Can be used instantly
- Single end connection
- Increased safety due to braiding
- High output
- Highest flexibility
- Does not damage the surfaces
- Low bending radius
- Easy to assemble



Gost

Type ELW-HS

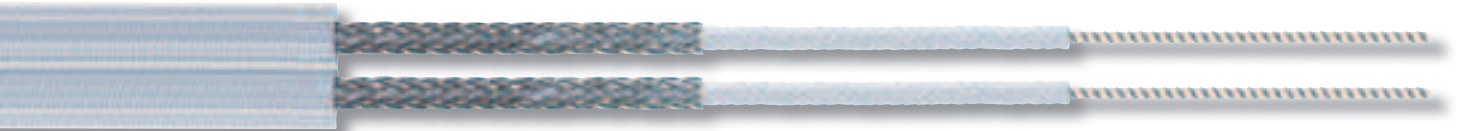

Application

It is used to heat devices, pipes, valves and systems in a non-corrosive and dry environment. The heating tape is highly flexible, does not damage the surfaces and is suitable for high output applications. The braiding provides

protection against mechanical damages and can be incorporated in the electrical protection measures.



Type ELW-HS up to 450 °C

Standards:

Manufactured according to DIN VDE 0721 T2
 Short term based on DIN VDE 0253 HNMFQMF 500
 Final inspection according to DIN VDE 0721 T411
 1.5 kV AC – 1 min

Technical data:

Insulation Textile e-glass
 Protective braid SS AISI 304
 Outer jacket Textile e-glass
 Output ~ 250 W/m*
 Operating temperature max. 450 °C when switched off
 Dimensions (W x H) 30 x 5 mm
 Bending radius flat minimum 10 mm
 Minimum installation temperature Not restricted
 Moisture resistant no
 Connection 1.2 m without plug (different cold cable length optionally available)
 Protection class I

* Information: The output per meter of heating cable and the maximum possible working temperatures depend on the respective application. We recommend that you contact our engineers on an individual basis – we will gladly assist you.

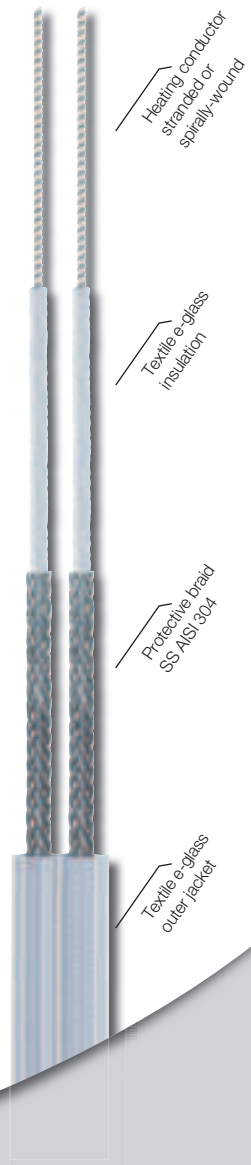

| Item name | Heated length (m) | Output approx. (W) | RL Ω/m | Item number |
|-------------|-------------------|--------------------|--------|-------------|
| ELW-HS 0.50 | 0.50 | 126 | 420.00 | 0240102 |
| ELW-HS 0.70 | 0.70 | 180 | 210.00 | 0240105 |
| ELW-HS 1.10 | 1.10 | 240 | 100.00 | 0240109 |
| ELW-HS 1.50 | 1.50 | 375 | 47.00 | 0240111 |
| ELW-HS 2.10 | 2.10 | 504 | 25.00 | 0240115 |
| ELW-HS 2.50 | 2.50 | 622 | 17.00 | 0240117 |

| Item name | Heated length (m) | Output approx. (W) | RL Ω/m | Item number |
|-------------|-------------------|--------------------|--------|-------------|
| ELW-HS 3.25 | 3.25 | 768 | 10.60 | 0240121 |
| ELW-HS 4.25 | 4.25 | 1090 | 5.71 | 0240124 |
| ELW-HS 5.00 | 5.00 | 1336 | 3.96 | 0240126 |
| ELW-HS 6.75 | 6.75 | 1757 | 2.23 | 0240130 |
| ELW-HS 8.25 | 8.25 | 2030 | 1.58 | 0240134 |

Further resistances available upon request

4/2009 · We reserve the right to make changes



eltherm®



- Factory terminated
- Highest output
- Highest working temperature
- Can be used instantly
- Highest flexibility
- Low bending radius
- Does not damage the surfaces



Type **ELK-Q**

Application

The preferred use of the heating cable is for glass, quartz or ceramic devices and systems with the highest output requirements in a dry environment. Low dimensions and high flexibility simplify assembly. The heating cable must be installed touch-protected. If you plan to use the heating

cable on metal and at an operating temperature in excess of 650 °C, consult our project engineers.



Type **ELK-Q** up to 900 °C

Standards:

Manufactured according to DIN VDE 0721 T2
 Short term based on DIN VDE 0253 HNMF 1000
 Final inspection according to DIN VDE 0721 T2
 1.5 kV AC – 1 min

Technical data:

Insulation Textile quartz
 Nominal voltage 230 V
 Output ~ 175 W/m*
 Operating temperature max.. 900 °C when switched off
 Diameter. 4 mm
 Minimum bending radius. . . . 5 x External-Ø
 Minimum installation temperature Not restricted
 Moisture resistant no
 Cold end length 1.2 m
 Protection class determined by installation

* Information: The output per meter of heating cable and the maximum possible working temperatures depend on the respective application. We recommend that you contact our engineers on an individual basis – we will gladly assist you.

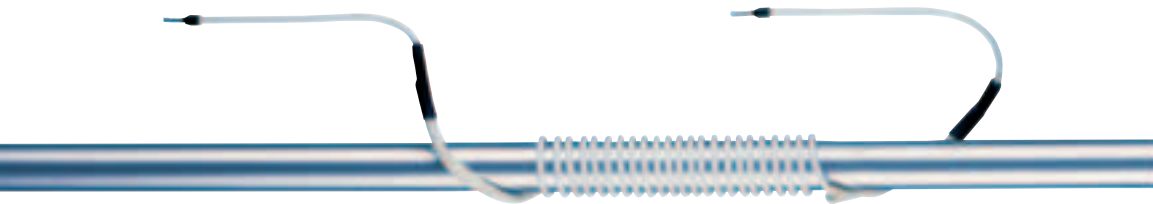

Heating conductor
stranded or
spray-wound

Textile quartz
insulation

| Item name | Heated length (m) | Output approx. (W) | RL Ω/m | Item number |
|-----------|-------------------|--------------------|--------|-------------|
| ELK-Q 0.6 | 0.6 | 106 | 830.00 | 0160003 |
| ELK-Q 1.2 | 1.2 | 138 | 320.00 | 0160006 |
| ELK-Q 1.4 | 1.4 | 270 | 140.00 | 0160007 |
| ELK-Q 2.0 | 2.0 | 319 | 83.00 | 0160011 |
| ELK-Q 3.1 | 3.1 | 533 | 32.00 | 0160014 |

| Item name | Heated length (m) | Output approx. (W) | RL Ω/m | Item number |
|------------|-------------------|--------------------|--------|-------------|
| ELK-Q 4.0 | 4.0 | 696 | 19.00 | 0160017 |
| ELK-Q 5.0 | 5.0 | 822 | 12.00 | 0160020 |
| ELK-Q 6.0 | 6.0 | 1062 | 8.30 | 0160023 |
| ELK-Q 8.0 | 8.0 | 1438 | 4.60 | 0160026 |
| ELK-Q 10.0 | 10.0 | 1653 | 3.20 | 0160029 |

Further resistances available upon request

4/2009 · We reserve the right to make changes



eltherm®

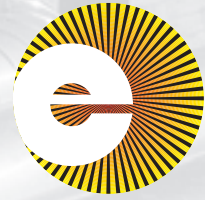

- Factory terminated
- Highest output
- Highest working temperature
- Can be used instantly
- Highest flexibility
- Low bending radius
- Does not damage the surfaces
- Single end connection



Type **ELW-Q**

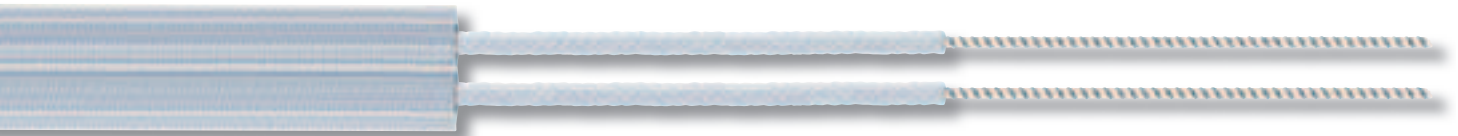

Application

It is used for glass, quartz or ceramic devices and systems with the highest output requirements in a dry environment. Single end connection and high flexibility simplify assembly. The heating tape must be installed touch-protected.

If you plan to use the heating cable on metal and at an operating temperature in excess of 650 °C, consult our project engineers.



Type **ELW-Q** up to 900 °C

Standards:

Manufactured according to DIN VDE 0721 T2
 Short term based on DIN VDE 0253 HNMFMF 1000
 Final inspection according to DIN VDE 0721 T2
 1.5 kV AC – 1 min

Technical data:

Insulation Textile quartz
 Outer jacket Textile quartz
 Output approx. ca. 350 W/m*
 Operating temperature max. 900 °C when switched off
 Dimensions (W x H) ~ 25 x 6 mm
 Bending radius flat minimum. 10 mm
 Minimum installation temperature Not restricted
 Moisture resistant no
 Connectionkabellänge 1.2 m
 Connection. option with plug available upon request

* Information: The output per meter of heating cable and the maximum possible working temperatures depend on the respective application. We recommend that you contact our engineers on an individual basis – we will gladly assist you.

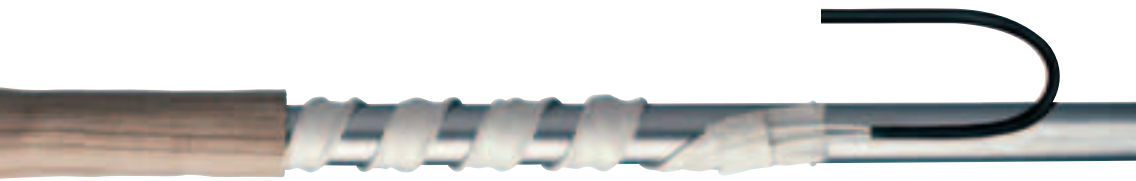
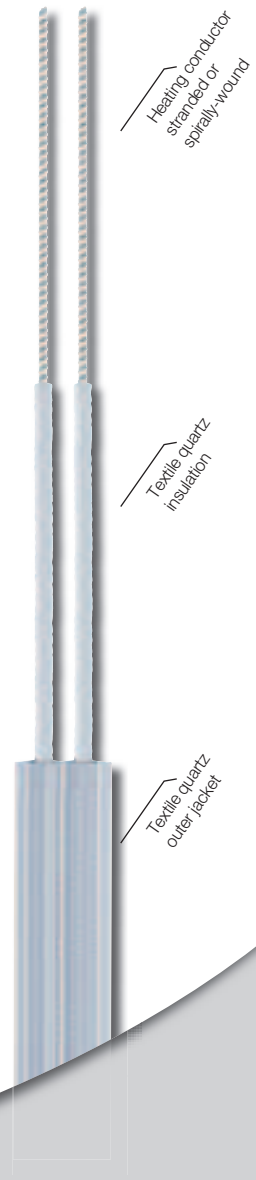

| Item name | Heated length (m) | Output approx. (W) | RL Ω/m | Item number |
|------------|-------------------|--------------------|--------|-------------|
| ELW-Q 0.60 | 0.60 | 138 | 320.00 | 0260003 |
| ELW-Q 0.70 | 0.70 | 270 | 140.00 | 0260005 |
| ELW-Q 1.00 | 1.00 | 319 | 83.00 | 0260008 |
| ELW-Q 1.55 | 1.55 | 533 | 32.00 | 0260012 |
| ELW-Q 2.00 | 2.00 | 696 | 19.00 | 0260014 |

| Item name | Heated length (m) | Output approx. (W) | RL Ω/m | Item number |
|------------|-------------------|--------------------|--------|-------------|
| ELW-Q 2.50 | 2.50 | 882 | 12.00 | 0260017 |
| ELW-Q 3.00 | 3.00 | 1062 | 8.30 | 0260020 |
| ELW-Q 4.00 | 4.00 | 1438 | 4.60 | 0260023 |
| ELW-Q 5.00 | 5.00 | 1653 | 3.20 | 0260026 |

Further resistances available upon request

4/2009 · We reserve the right to make changes

eltherm®



- Factory terminated
- Hermetically sealed metal sheath
- Highly robust and mechanically stable under load
- Moisture proof
- High chemical resistance
- High output per m



Type ELK-MI/F



Application

Factory terminated heating cable, suitable for assembly on systems, apparatus, receptacles, pipes, valves and similar. Moisture proof applications at high outputs and temperatures. Can be immersed in fluids. We also provide this version for hazardous areas.

Information: Avoid frequent bending with a minimal bending radius (risk of breakage and micro cracks).



Type ELK-MI/F up to 400 °C

Technical data:

Insulation Magnesium oxide
 Outer jacket alloy outer jacket
 Nominal voltage 500 V
 Output max up to 150 W/m*, dependent on the operating temperature
 Operating temperature max.. up to 600 °C when switched off
 Minimum bending radius. . . . 5 x External-Ø
 Minimum installation temperature Not restricted
 Moisture resistant yes
 Cable gland M 20 x 1.5
 Cold lead length on both sides 0.7 m

* Information: The output per meter of heating cable and the maximum possible working temperatures depend on the respective application. We recommend that you contact our engineers on an individual basis – we will gladly assist you.

| Nominal resistance (Ω/m) | Outer Diameter (mm) | Multiplication factor ★ |
|--------------------------|---------------------|-------------------------|
| 0.16 | 4.9 | 1.40 |
| 0.25 | 4.4 | 1.27 |
| 0.40 | 4.0 | 1.16 |
| 0.63 | 3.7 | 1.08 |
| 1.00 | 3.4 | 1.00 |
| 1.60 | 3.2 | 0.93 |

| Conductor cross-section (mm ²) | Outer Diameter (mm) |
|--|---------------------|
| 2.5 | 5.3 |
| 6.0 | 6.4 |

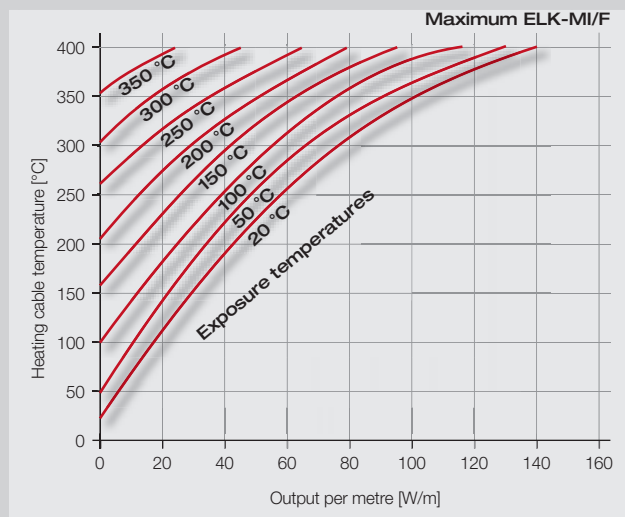
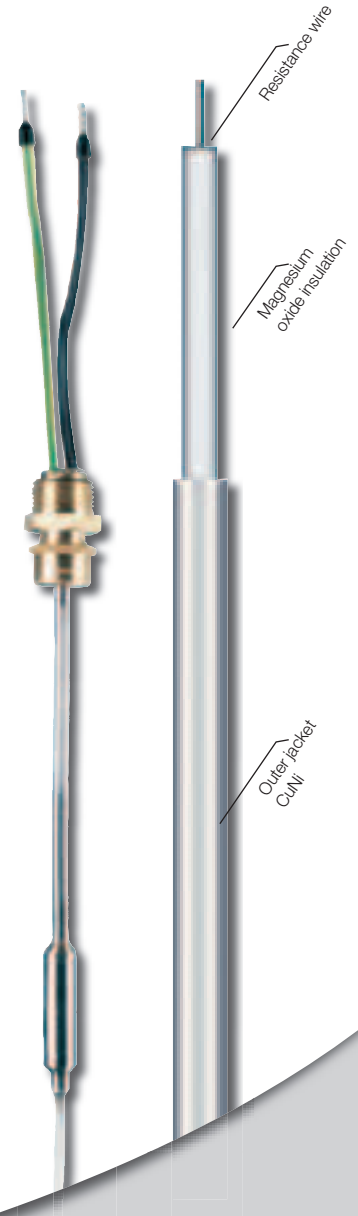

Information regarding design:

The maximum operating temperature (pipe and surface temperature) is generally known for electrical heating system. This is the exposure temperature for the heating. If you track the respective “exposure temperature” curve, there is a correlation between the heating cable temperature (vertically) and specific output (horizontally).

The specific output must be multiplied by the existing heating cable factor as the heating cable diameter and material must be taken into account for design.

Consult our project engineers.

eltherm®



- Factory terminated
- Hermetically sealed metal sheath
- Highly robust and mechanically stable under load
- Moisture proof
- High chemical resistance
- Highest working temperature
- Highest output per m



Gost



Type ELK-MI/VA



Application

Factory terminated heating cable, suitable for assembly on systems, apparatus, receptacles, pipes, valves and similar in a corrosive and rough environment. Moisture proof applications with highest output and temperatures. Can be immersed in fluids. Due to the high permissible surface

temperatures, the heating cable can also be used as an infrared dark radiator.

eltherm® also supplies this model for use in hazardous applications, please refer to the catalogue for further data: heating and accessories for hazardous applications.



Type ELK-MI/VA up to 600 °C

Technical data:

Insulation Magnesium oxide
 Outer jacket SS AISI 321
 Nominal voltage 500 V
 Output max Refer to information on design
 Operating temperature max.. Refer to information on design
 Minimum bending radius. 5 x External-Ø
 Minimum installation temperature Not restricted
 Moisture resistant yes
 Cable gland M 20 x 1.5
 Cold lead length on both sides 0.7 m (standard, other lengths possible)

| Nominal resistance | Outer Diameter (mm) | Multiplication factor ★ |
|--------------------|---------------------|-------------------------|
| 0.16 | 6.5 | 1.86 |
| 0.25 | 5.3 | 1.55 |
| 0.40 | 4.7 | 1.40 |
| 0.63 | 4.3 | 1.30 |
| 1.00 | 3.9 | 1.19 |
| 1.60 | 3.6 | 1.11 |
| 2.50 | 3.4 | 1.05 |
| 4.00 | 3.2 | 1.00 |
| 6.30 | 3.2 | 1.00 |
| 10.00 | 3.2 | 1.00 |

| Connector cross-section (mm ²) | Outer Diameter (mm) |
|--|---------------------|
| 2.5 | 5.3 |
| 6.0 | 6.4 |

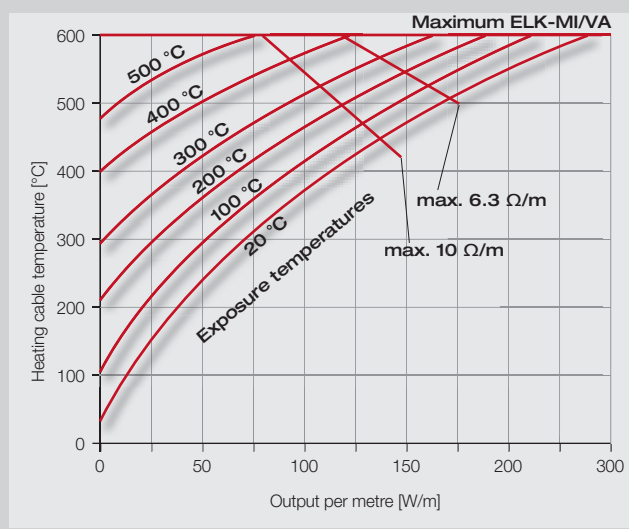
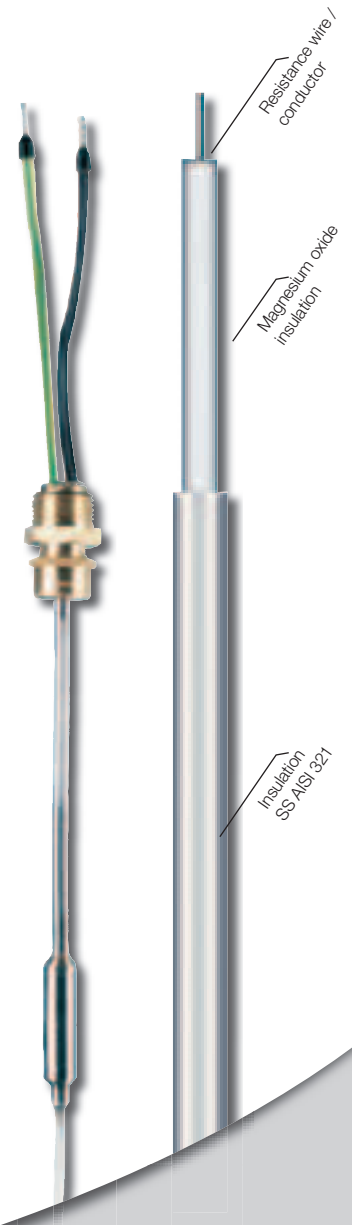

Information regarding design:

The maximum operating temperature (pipe and surface temperature) is generally known for electrical heating system. This is the exposure temperature for the heating. If you track the respective "exposure temperature" curve, there is a correlation between the heating cable temperature (vertically) and specific output (horizontally).

The specific output must be multiplied by the existing heating cable factor as the heating cable diameter and material must be taken into account for design.

Consult our project engineers.

eltherm®

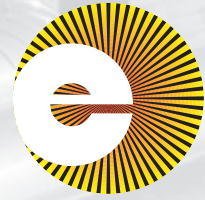

- Long heating circuit lengths
- Simple termination
- Different nominal voltages
- Moisture proof
- Highly flexible



Type **ELW-3-FEP/PVC**



Application

The eltherm® ELW-3-FEP/PVC was developed for specific customer demands – the requirement was to cover very long distances with one heating cable. The heating cable is applied for frost protection, a typical application range are for example pipes in tunnels.

The heating cable consists of three high-quality resistance wires with an insulation out of chemically resistant FEP. Additionally the heating cable is protected by a PVC outer jacket.

A simple installation is ensured.



Type **ELW-3-FEP/PVC**

up to 105 °C

Technical data:

Insulation FEP
 Outer jacket PVC
 Colour grey
 Nominal voltage 300/500 V
 Output max. 25 W/m
 Operating temperature max. 90 °C when
 switched off

Short term
 operating temperature 105 °C
 Insulation thickness 1 mm
 Bending radius 30 mm



| Type | Resistance Ω/m | Minimum heating circuit length* in m (400 V/Star) | Dimension in mm (+/- 0.2 mm) | Item number |
|--------------------------|-----------------------|---|------------------------------|-------------|
| 3 x 0.50 mm ² | 0.0342 | 435 | 5.2 x 17.1 | 03T0342 |
| 3 x 0.75 mm ² | 0.0238 | 520 | 5.2 x 17.1 | 03T0238 |
| 3 x 1.00 mm ² | 0.0171 | 610 | 5.2 x 17.1 | 03T0171 |
| 3 x 1.50 mm ² | 0.0115 | 750 | 5.2 x 17.1 | 03T0115 |
| 3 x 2.50 mm ² | 0.0070 | 952 | 8.0 x 20.6 | 03T0070 |
| 3 x 4.00 mm ² | 0.0043 | 1215 | 8.0 x 20.6 | 03T0043 |
| 3 x 6.00 mm ² | 0.0029 | 1480 | 8.0 x 20.6 | 03T0029 |

* Attention: The minimal heating circuit length may not be undercut.
 Please contact our engineers in case of questions.



eltherm®

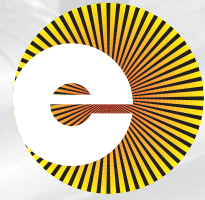

- Low outer diameter
- Highly flexible
- Moisture proof
- Low bending radius
- Different nominal voltages



Type EL-Floor Single/Twin



Application

The EL-Floor heating cables are our floor heating cables, available in the versions EL-Floor-Single and EL-Floor-Twin. These moisture resistant heating cables are sewn onto or glued to thin bed heating mats for example and used to heat floors, walls and similar. Due to the low outer diameter, the EL-Floor heating cables boast a wide range of applications, also making them especially well-suited

for renovation work. The heating cable EL-Floor-Twin is also equipped with the return conductor as heating cable, distributing the heating output on the full section between 2 heating cables. Both EL-Floor heating cables can be delivered in all RAL colours upon request. Their further important features include the low bending radius and high flexibility.



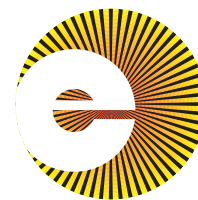

| Abbreviated marking | Description | Item number |
|--|---|-------------|
| 1 Connection and termination kits | | |
| ELVB10 | ELVB10 connection / termination set for heating cable ELP/Si with cable gland M25 | 0911040 |
| ELVB08 | Connection / termination set for heating cables ELP/FEP and ELP/PFA with cable gland M20 | 0911032 |
| ExCon small | Connection sleeve for the hazardous area ELK-AG, Ø 25 mm, length 115 mm | 0X81115 |
| ExCon big | Connection sleeve for the hazardous area ELK-AG, Ø 36 mm, length 175 mm | 0X81120 |
| ELVB22 | Connection set for heating cable ELKM-A for 1.5 mm ² | 0911048 |
| ELVB26 | Connection set for heating cable ELKM-AS for 1.5 mm ² | 0911052 |
| ELVB30 | Connection set for heating cable ELKM-AG for 1.5 mm ² | 0911056 |
| ELVB30-1 | Connection set for heating cable ELKM-AG for 2.5 mm ² | 0911058 |
| 2 Junction boxes | | |
| ELAK-Ex 3 | Junction box, 122 x 120 x 90 mm, polyester housing, for ELK-AG | 0X80052 |
| ELAK-Ex 3 | Junction box, 122 x 120 x 90 mm, polyester housing, for ELW-VA | 0X80053 |
| ELAK-Ex 3 | Junction box, 122 x 120 x 90 mm, polyester housing, for AG + EL-CT | 0X80054 |
| ELAK-Ex 3 | Junction box, 122 x 120 x 90 mm, polyester housing, for EL-CTC | 0X80055 |
| ELAK-Ex 3 | Junction box, 122 x 120 x 90 mm, polyester housing, for ELW-VA + EL-CT | 0X80056 |
| ELAK-Ex 3 | Junction box, 122 x 120 x 90 mm, polyester housing, for Pt100 | 0X80058 |
| ELAK-Ex-R | Junction box, Ø 150 mm, height 125 mm, polyester housing, for ELK-AG | 0X80072 |
| ELAK-Ex-R | Junction box, Ø 150 mm, height 125 mm, polyester housing, for ELW-VA | 0X80073 |
| ELAK-Ex-R | Junction box, Ø 150 mm, height 125 mm, polyester housing, for AG + EL-CT | 0X80074 |
| ELAK-Ex-R | Junction box, Ø 150 mm, height 125 mm, polyester housing, for EL-CTC | 0X80075 |
| ELAK-Ex-R | Junction box, Ø 150 mm, height 125 mm, polyester housing, for ELW-VA + EL-CT | 0X80076 |
| ELAK-Ex-R | Junction box, Ø 150 mm, height 125 mm, polyester housing, for Pt100 | 0X80078 |
| ELAK-2 | Junction box, 98 x 98 x 58 mm, polyester housing | 0920001 |
| ELAK-5 | Junction box, 122 x 120 x 90 mm, polyester housing | 0920013 |
| ELAK-5 | Junction box, 130 x 130 x 75 mm, polyester housing | 0920002 |
| ELAK-6 | Junction box, 220 x 120 x 90 mm, polyester housing | 0920016 |
| ELAK-7 | Junction box, 260 x 190 x 90 mm, polyester housing | 0920019 |
| 3 Pipe mounting brackets | | |
| ELMW-5 | Pipe mounting brackets for ELAK-2 | 0941005 |
| ELMW-9 | Pipe mounting brackets for ELAK-Ex-3, ELAK-Ex-4, and ELAK-5 | 0941009 |
| ELMW-11 | Pipe mounting brackets for ELAK 5.1 | 0941011 |
| ELMW-13 | Pipe mounting brackets for ELAK-6 | 0941013 |
| ELMW-15 | Pipe mounting brackets for ELAK-7 | 0941015 |
| 4 Insulation entry kits | | |
| ELISD-1.12 | Insulation entry kit for insulation entry dimensions 70 x 70 mm, insulated area 3.5...7 mm | 0921011 |
| ELISD-1.16 | Insulation entry kit for insulation entry dimensions 70 x 70 mm, insulated area 4.5...10 mm | 0921015 |
| ELISD-1.20 | Insulation entry kit for insulation entry dimensions 70 x 70 mm, insulated area 7...13 mm | 0921019 |
| ELISD-1.25 | Insulation entry kit for insulation entry dimensions 70 x 70 mm, insulated area 9...17 mm | 0921023 |
| ELISD-P1 | Insulation entry kit for heating cables ELP/PFA and ELP/PFA, insulation entry 70 x 70 mm | 0921027 |
| ELISD-P2 | Insulation entry kit for heating cable ELP/Si, insulation entry 70 x 70 mm | 0921031 |

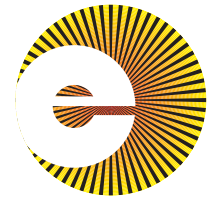

5 Temperature sensors

| | | |
|-------------|---------------------------------------|---------|
| ELTF-PTEx.2 | PT 100, EExe, 4-core, 3 m PTFE cable | 0X70002 |
| ELTF-PTEx.2 | PT 100, EExe, 4-core, 10 m PTFE cable | 0X70010 |

6 Self-adhesive tapes and foils

| | | |
|---------|---|------------|
| ELB-02 | 20 m adhesive glass fibre tape, 12 mm wide, maximum working temperature 140 °C | 2486800125 |
| ELB-02A | 30 m adhesive glass fibre tape, 12 mm wide, maximum working temperature 180 °C | 2486800126 |
| ELB-03 | 50 m adhesive fabric tape, 12 mm wide, maximum working temperature 90 °C | 2481800120 |
| ELB-06C | 50 m self-adhesive aluminium foil, 45 mm wide, reinforced grid, maximum working temperature 80 °C | 2701900051 |
| ELB-06D | 100 m self-adhesive aluminium / PE foil, 75 mm wide, maximum working temperature 140 °C | 2701900076 |

7 Mechanical fasteners

| | | |
|-----------|--|------------|
| ELB-16.10 | Plastic strap retainers, maximum length 102 mm Working temperature | 2796000001 |
| ELB-16.20 | Plastic strap retainers, maximum length 200 mm Working temperature | 2796000002 |
| ELB-16.36 | Plastic strap retainers, maximum length 360 mm Working temperature | 2796000003 |
| ELB-11 | Glass-cloth hose, 2 mm maximum Working temperature 450 °C, for attaching textile glass products | 2446000201 |
| ELB-21 | Quartz-cloth hose, 3.5 mm maximum Working temperature 1000 °C, for attaching textile quartz products | 2447000350 |
| ELB-15.04 | Clamping collar material SS AISI 304, clamping range 25/40 mm, maximum working temperature 450 °C | 2723001025 |
| ELB-15.06 | Clamping collar material SS AISI 304, clamping range 40/60 mm, maximum working temperature 450 °C | 2723001040 |
| ELB-15.09 | Clamping collar material SS AISI 304, clamping range 70/90 mm, maximum working temperature 450 °C | 2723001070 |
| ELB-15.11 | Clamping collar material SS AISI 304, clamping range 90/110 mm, maximum working temperature 450 °C | 2723001090 |
| ELB-13V1 | Pipe attachment band, 11 mm, material SS AISI 304, max. working temperature 450 °C | 2723001010 |
| ELB-13V2 | Lock for ELB-13V1, material SS AISI 304, max. working temperature 450 °C / packaged as 10 units | 2723001011 |
| ELB-12 | Pre-punched metall fixing strip, grid 25 mm SS AISI 304 for the attachments of heating cables on receptacles | 2723001005 |
| ELB-09 | Metallic gauze tape 50 mm x 10 m, material SS AISI 304 | 2793000050 |

8 Heat transfer cement

| | | |
|--------|---|------------|
| ELWZ 5 | Heat transfer cement, 18.3 KG bucket, max. working temperature 1,000 °C | 2979002951 |
|--------|---|------------|

9 Warning labels

| | | |
|----------|---|------------|
| EL-WS01D | German warning label "Elektrische Begleitheizung" * | 2986900002 |
| EL-WS01E | English warning label "Electric Heat Tracing" * | 2986900012 |

* Also available in other languages upon request.

10 Heat resistant cables / temperature-resistant cold ends

| | | |
|----------|---|------------|
| ELVB-L15 | Cold cable 1.5 mm ² for heating cable ELKM-AG | 2045511150 |
| ELVB-L25 | Cold cable 2.5 mm ² for heating cable ELKM-AG | 2045511250 |
| ELVB-L01 | Ni conductor 1.5 mm ² , maximum working temperature 450 °C, 550 °C transient | 2216301500 |
| ELVB-L02 | Ni conductor 2.5 mm ² , maximum working temperature 450 °C, 550 °C transient | 2216302500 |

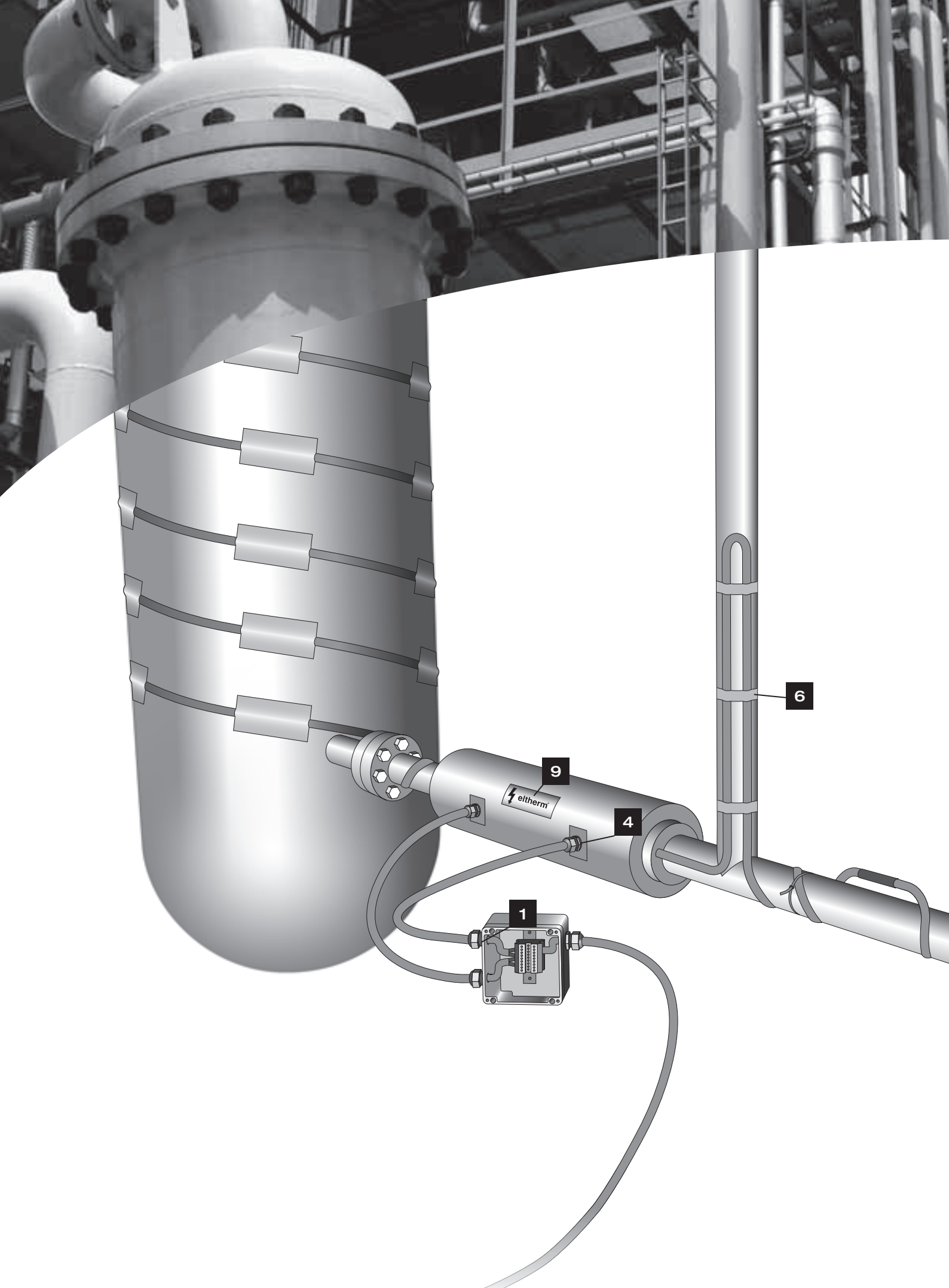

eltherm®

